

(No Model.)

2 Sheets—Sheet 1.

J. B. HABERLE. STREET SPRINKLER.

No. 467,503.

Patented Jan. 26, 1892.

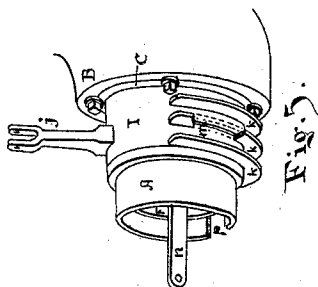

Fig. 5.

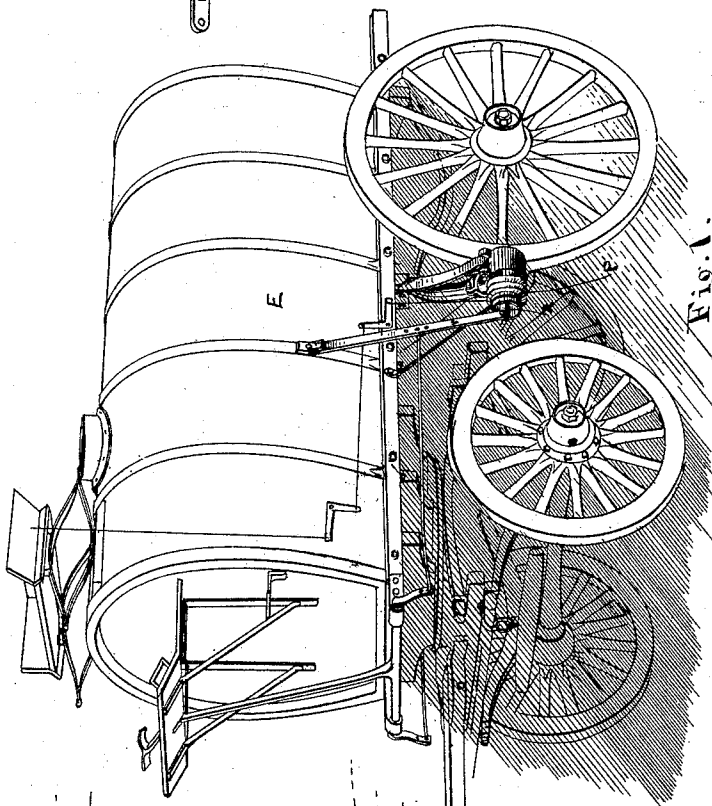

Fig. 1.

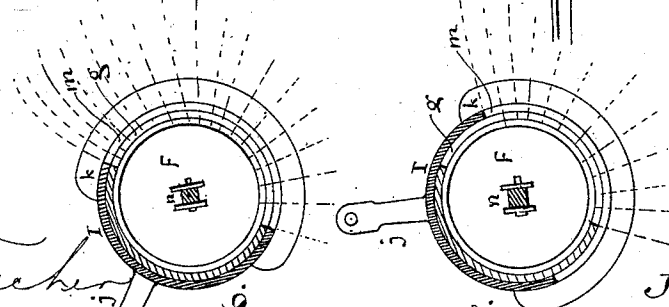

Fig. 6.

Fig. 7.

Witness
J. Traubner
C. Endlich

Inventor
John B. Haberle
 By his Atty
A. DeFruite

(No Model.)

2 Sheets—Sheet 2.

J. B. HABERLE.
STREET SPRINKLER.

No. 467,503.

Patented Jan. 26, 1892.

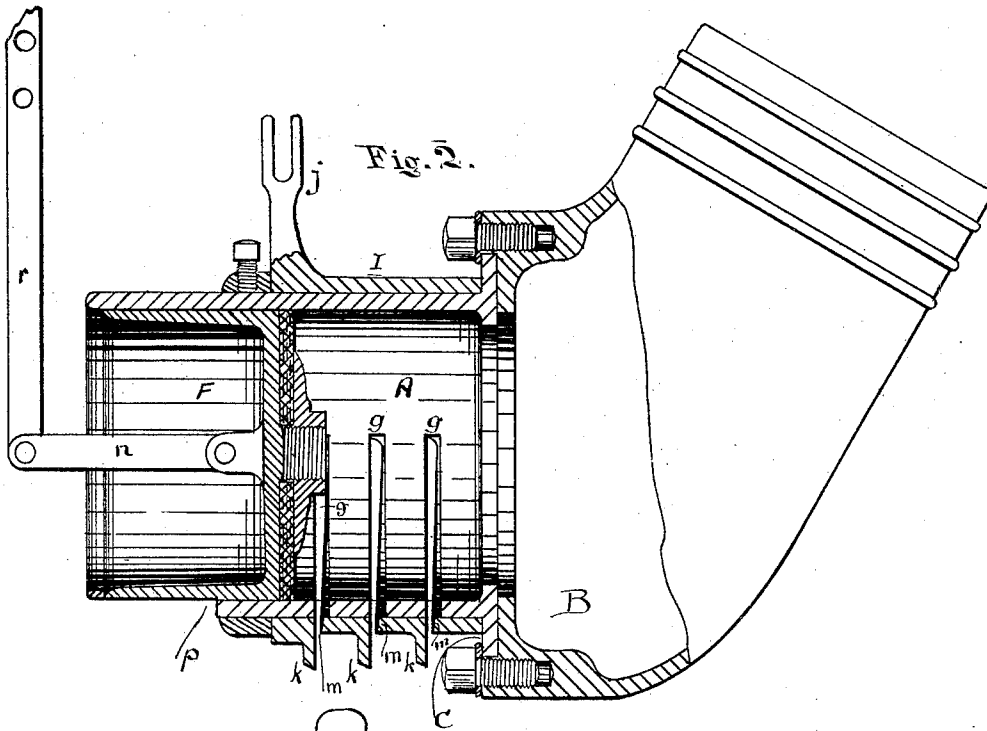

Fig. 3.

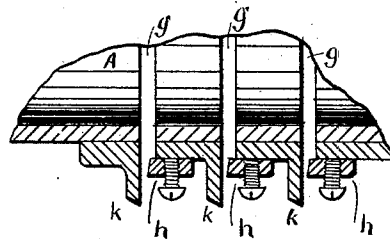
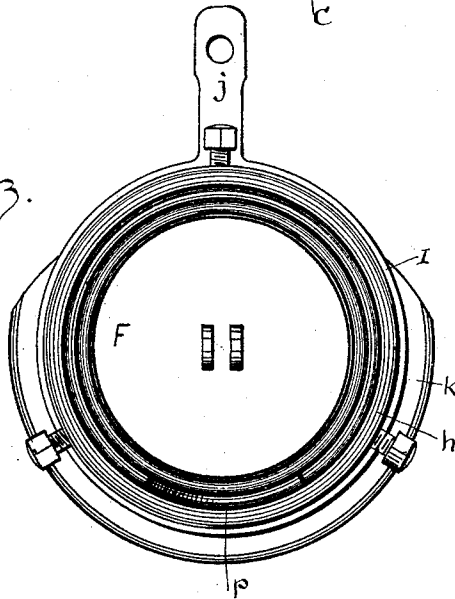

Fig. 4.

WITNESSES:
J. G. Fischer
H. Endlich

INVENTOR
John B. Haberle
 BY
P. D. Smith
 ATTORNEY

UNITED STATES PATENT OFFICE.

JOHN B. HABERLE, OF SOUTH BEND, INDIANA.

STREET-SPRINKLER.

SPECIFICATION forming part of Letters Patent No. 467,503, dated January 26, 1892.

Application filed September 16, 1891. Serial No. 405,912. (No model.)

To all whom it may concern:

Be it known that I, JOHN B. HABERLE, of South Bend, St. Joseph county, in the State of Indiana, have invented new and useful
5 Improvements in Street-Sprinklers; and I do hereby declare that the following is a full and accurate description of the same, reference being had to the accompanying drawings, wherein—

10 Figure 1 is a perspective view showing my invention in operative position. Fig. 2 is a vertical longitudinal section of the sprinkler-head. Fig. 3 is an end elevation of the same. Fig. 4 is a partial section of the head, showing
15 the slot-adjusting rings. Fig. 5 is a perspective view of the sprinkler-head. Figs. 6 and 7 are transverse sections of said head through one of the jet-slots, showing effect of sleeve cut-off.

20 The practice of sprinkling the roadways in cities and towns by means of perambulating sprinkler-wagons has now become a public necessity and many devices have been invented seeking the best and most satisfactory
25 distribution of the sprinkling-water. Experience has developed qualifications and restrictions on this service not thought of originally and not heretofore provided for. This invention is directed to satisfy some of these
30 desired qualifications. For instance, the wetting of the cross-walks by the traveling sprinkler is highly objectionable to pedestrians, and yet it is exceedingly difficult, if not impossible, for the sprinkler in common
35 use to approach closely to the cross-walk with the wetted area without encroaching upon the cross-walk. Then, too, the sprinkler is located so far behind the driver that he cannot properly observe and control the issue of the water.

40 My present invention obviates these objections, first, by means of vertical jets projected in a direction lateral to the line of progression, which makes the jets parallel with the cross-walk, and, second, by a location in front of
45 the rear wheels where the jets are easily under the observation of the driver. These two constitute a feature not heretofore produced in street-sprinklers, and by them it becomes possible easily to sprinkle close to the cross-walk on both sides without wetting the same.

50 My invention also relates to the structure of the sprinkler-head wherein the issue-open-

ings consist of slots through which the jet-water is delivered in sheets. Said slots are parallel; and my improvements are, first, parallel flanges between said slots to direct
55 sheet jets of issuing water; second, a piston-valve, whereby one or more of said jets may be cut off by covering and closing one or more of the jet-slots; third, the annular rings, whereby the jet-orifices may be increased or
60 diminished in width; fourth, a rotating sleeve, whereby the position of the issuing jet may be controlled by variations in the effective length of the issue-slot.

65 A is a hollow cylinder, preferably of brass or other non-corrodible metal. For convenience of attachment to a hose-coupler B, the cylinder A is provided with a lateral flange c, which projects under the heads of the clamping-screws d, and at the same time admits any
70 required rotary adjustment of the cylinder A in "setting" it for use. The inner end of the cylinder A is open for the free admission of water from the tank E through the coupler B. The outer end of the said cylinder may be
75 open or closed, as preferred; but I leave it entirely open for the free admission of the piston-valve F, which is fitted to move freely, but yet "water-tight," within said cylinder. Slots g g are cut in the side of the cylinder A
80 for the escape of the water. Said slots are parallel, transverse to the axis of the cylinder, and about one-half or three-fourths of an inch apart. Their length is equal to about
85 one-half the periphery of the cylinder; but this is immaterial and undetermined. If the service is known, the width of the slots may be determined before they are cut, so as to insure the desired thickness of issuing water
90 sheet; but if the service is not previously known they may be provided with exterior adjusting-rings h, whereby the effective width of the slots may be varied to suit the requirements of the user.

95 It always happens that for one reason or another it is desirable temporarily to cut off a part of the issuing water without diminishing the number of jets—as, for instance, in passing along a street if a carriage passing or
100 standing by the curb would receive the upper margins of the issuing jets then it would be highly desirable to cut off the upper margins without interfering with the flow. This

I accomplish by placing on the exterior surface of the cylinder a sleeve I, provided with slots *m*, which register with the slots *g g*, and also provided with an arm *j*, by means of which proper appliances may be attached to rotate said sleeve and cause the slots *g g* to be cut off at their ends, and thus reduce the marginal extent of the issuing water, as and for purposes similar to that described before.

10 The appliances referred to may be such as will enable the driver to manipulate and control the sleeve I at will.

At the margin of each slot is a flange *k k k*, projecting in a plane lateral as to the surface of the cylinder. The issuing water traverses the surface of this flange and is directed thereby in a smooth unbroken sheet into the air. The presence of this flange is beneficial in that regard and enables the issuing sheet to remain unbroken much longer than would otherwise be possible. The distance of projection is therefore greater. The piston-valve F is provided with a lever *r* and link *n*. Said lever is fulcrumed upon the wagon-frame at some convenient point and its free end extends to a point within convenient reach of the driver on his seat. At the lower side of the cylinder A there is a gap *p*, which, when the piston-valve F is drawn far backward, so as to uncover said gap, the same acts as a vent for the quick discharge of the water within the coupler B and the hose which leads to the tank.

In Fig. 1 is represented a sprinkling-wagon of familiar form and not unlike wagons in common use except in the particulars of the structure of the sprinkler, as above described, and the location of the same in front of the rear wheels, as set forth. These constitute the matters which I think myself the first inventor of.

It will appear evident that the jets may issue through a series of slots or holes arranged in parallel rows instead of continuous

slots without in any way changing the character or mode of operation of this invention; but such change would not be in the direction of improvement. It is also apparent that the sleeve I can be placed inside the permanent cylinder A and be rotatable, for the purpose set forth, and I therefore contemplate such changes as included within the scope of my invention.

Having described my invention, I claim as new—

1. The cylindrical sprinkler-head A, provided with the jet-slots *g g*, the sleeve I, capable of rotation and provided with slots corresponding and registering with the slots *g*, and means for rotating said sleeve at will, substantially as set forth.

2. The cylindrical sprinkler-head A, provided with the slots *g g* in parallel series, combined with the piston-valve F, provided with means for moving the same at will, and the rotatable sleeve I, provided with slots corresponding and registering with the slots *g g*, substantially as set forth.

3. The cylindrical sprinkler-head A, provided with the slots *g g* in parallel series, the rotatable sleeve I, exterior to said head A and provided with slots corresponding and registering with the slots *g g*, and means for rotating said sleeve at will, substantially as set forth.

4. The cylindrical sprinkler-head A, provided with slots *g g*, and the rotatable sleeve I, provided with slots corresponding and registering with the slots *g g* and also provided with the marginal flanges *k k* to receive and direct the issuing water, substantially as set forth.

JOHN B. HABERLE.

Witnesses:

C. M. COLLINS,
W. H. BRAMAN.