

F. O. FARWELL.
 INTERNAL COMBUSTION MOTOR.
 APPLICATION FILED FEB. 28, 1911.

1,155,138.

Patented Sept. 28, 1915.

6 SHEETS—SHEET 1.

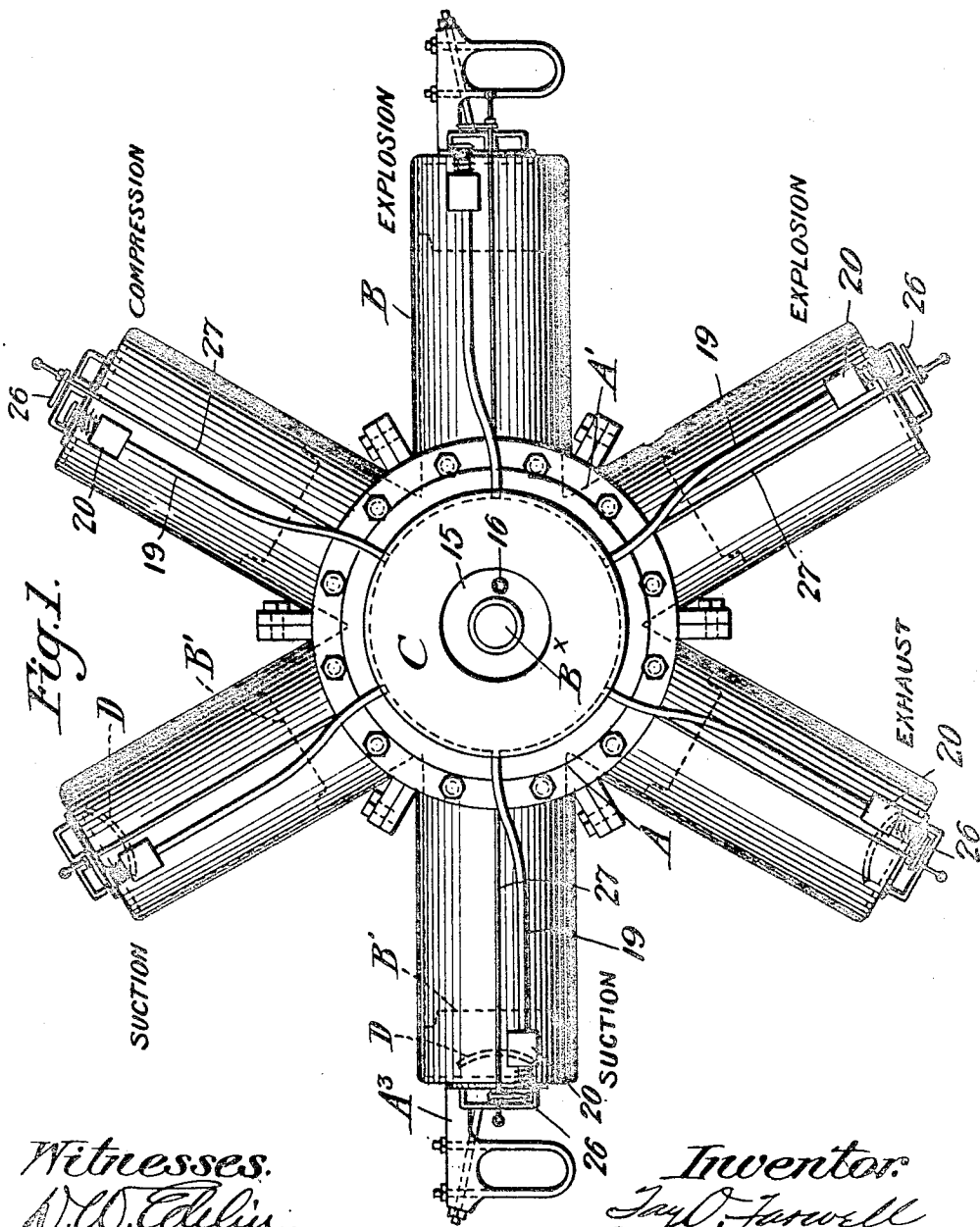

Witnesses:
 D. W. Collins.

[Handwritten signature]

Inventor:

[Handwritten signature: F. O. Farwell]
[Handwritten signature: Lewis & Clark]

F. O. FARWELL.
 INTERNAL COMBUSTION MOTOR.
 APPLICATION FILED FEB. 28, 1911.

1,155,138.

Patented Sept. 28, 1915.

6 SHEETS—SHEET 2.

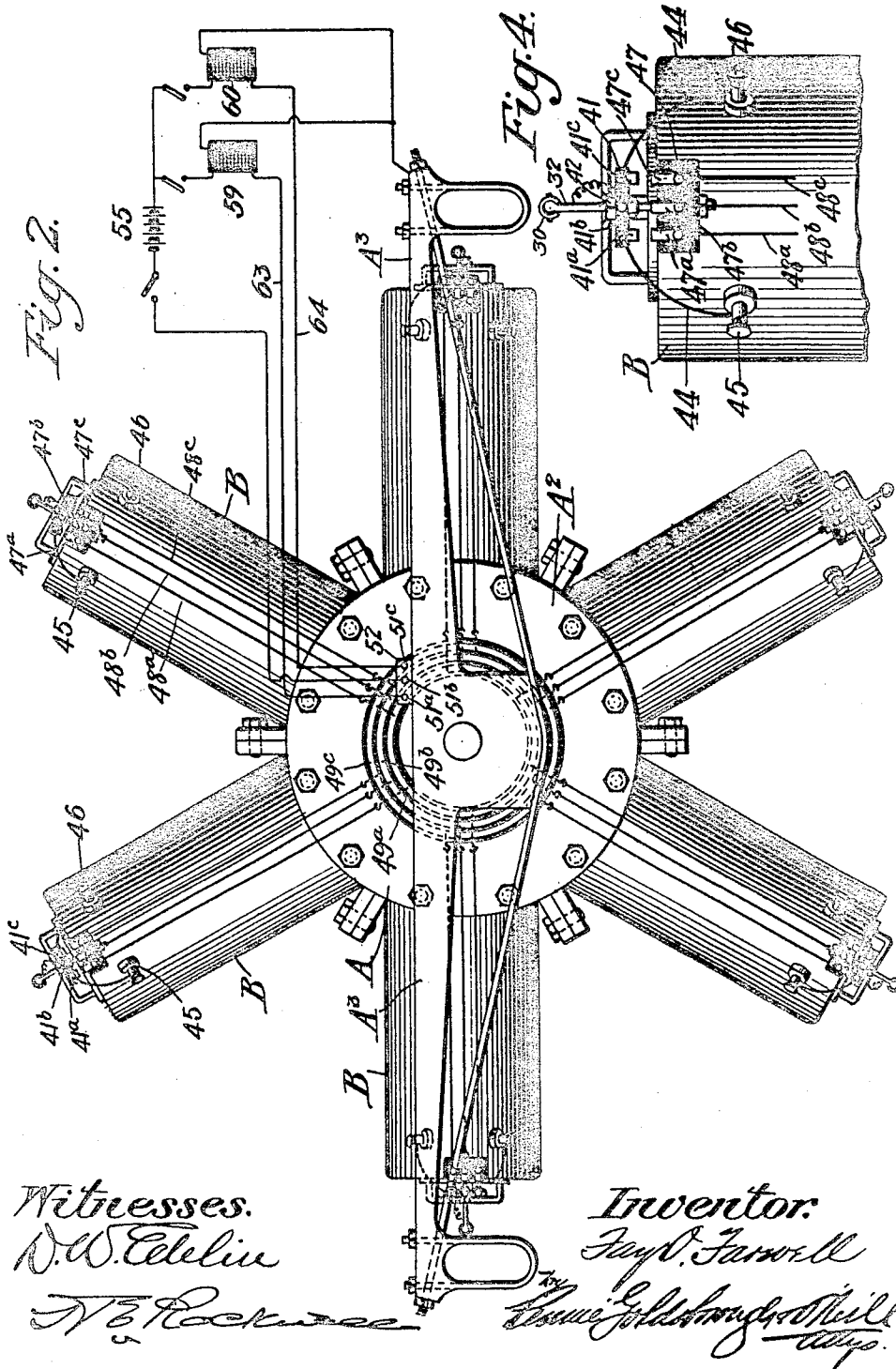

Witnesses:
 D. W. Edlin
 N. B. Rockwell

Inventor:
 F. O. Farwell
 Louis J. G. ...

F. O. FARWELL.
 INTERNAL COMBUSTION MOTOR.
 APPLICATION FILED FEB. 28, 1911.

1,155,138.

Patented Sept. 28, 1915.

6 SHEETS—SHEET 3.

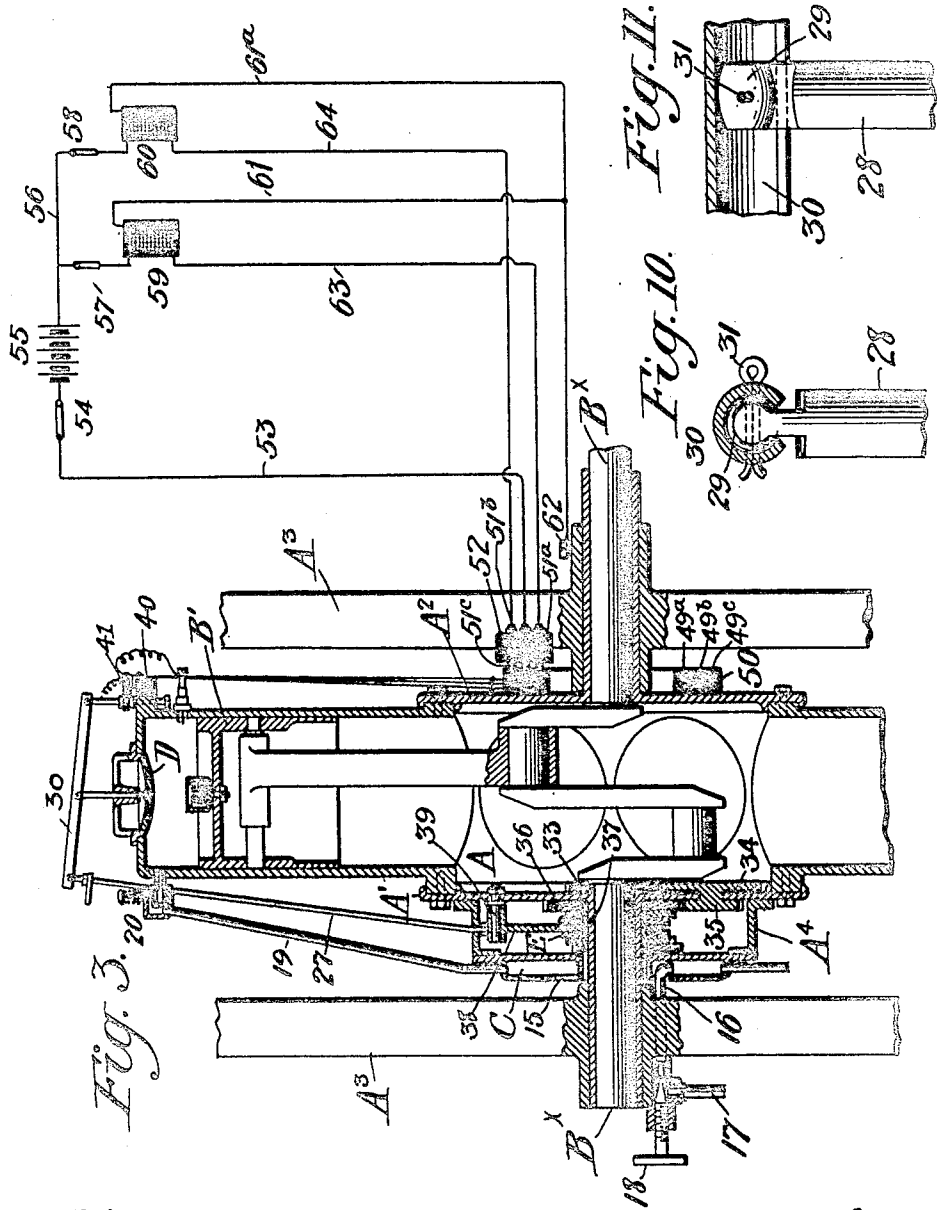

Witnesses:
 D. W. Edlin
 J. E. Rockwood

Inventor:
 F. O. Farwell
 Lewis Johnson & Meill
 Attys

F. O. FARWELL.
 INTERNAL COMBUSTION MOTOR.
 APPLICATION FILED FEB. 28, 1911.

1,155,138.

Patented Sept. 28, 1915.
 6 SHEETS—SHEET 4.

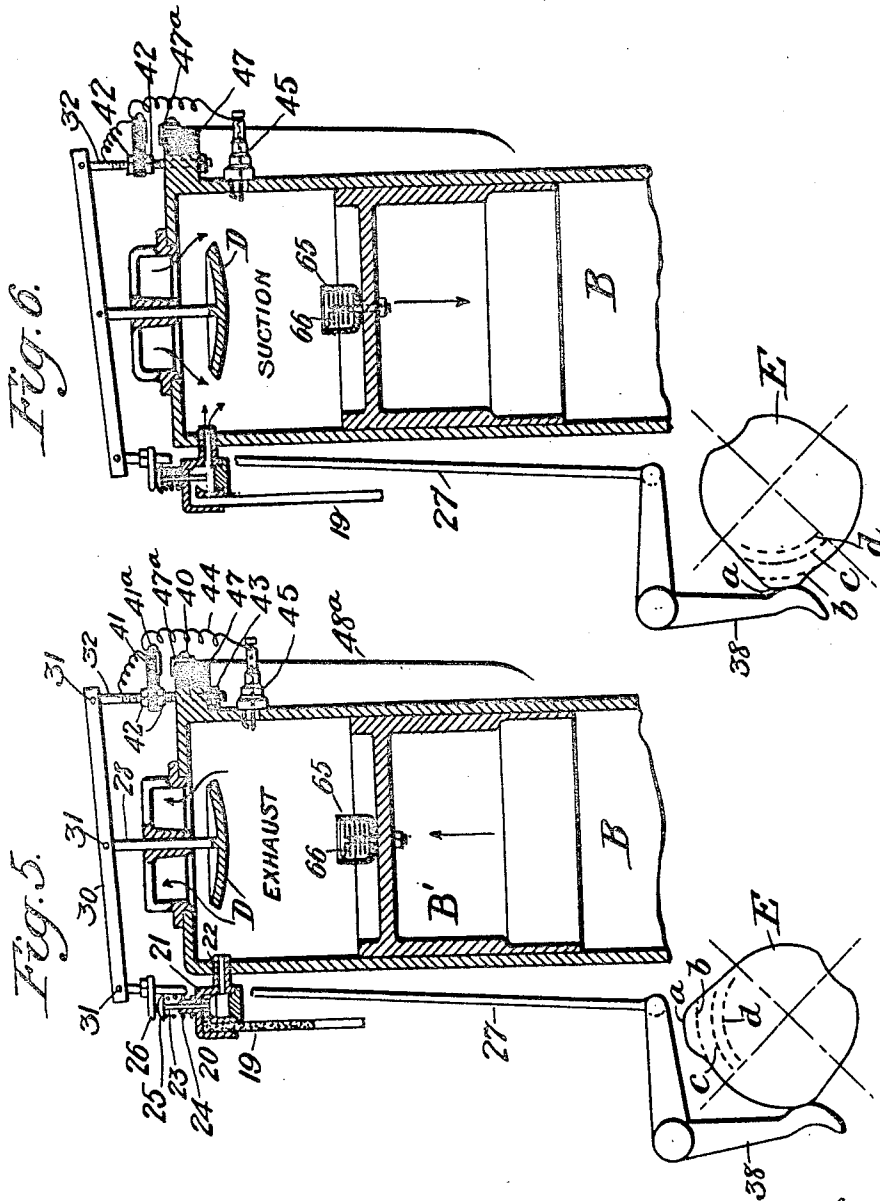

Witnesses:
 D. W. Edelin
 J. P. Rockwell

Inventor:
 Fayl O. Farwell
 by *Wm. J. Glendon Mill*

F. O. FARWELL.
 INTERNAL COMBUSTION MOTOR.
 APPLICATION FILED FEB. 28, 1911.

1,155,138.

Patented Sept. 28, 1915.
 6 SHEETS—SHEET 5.

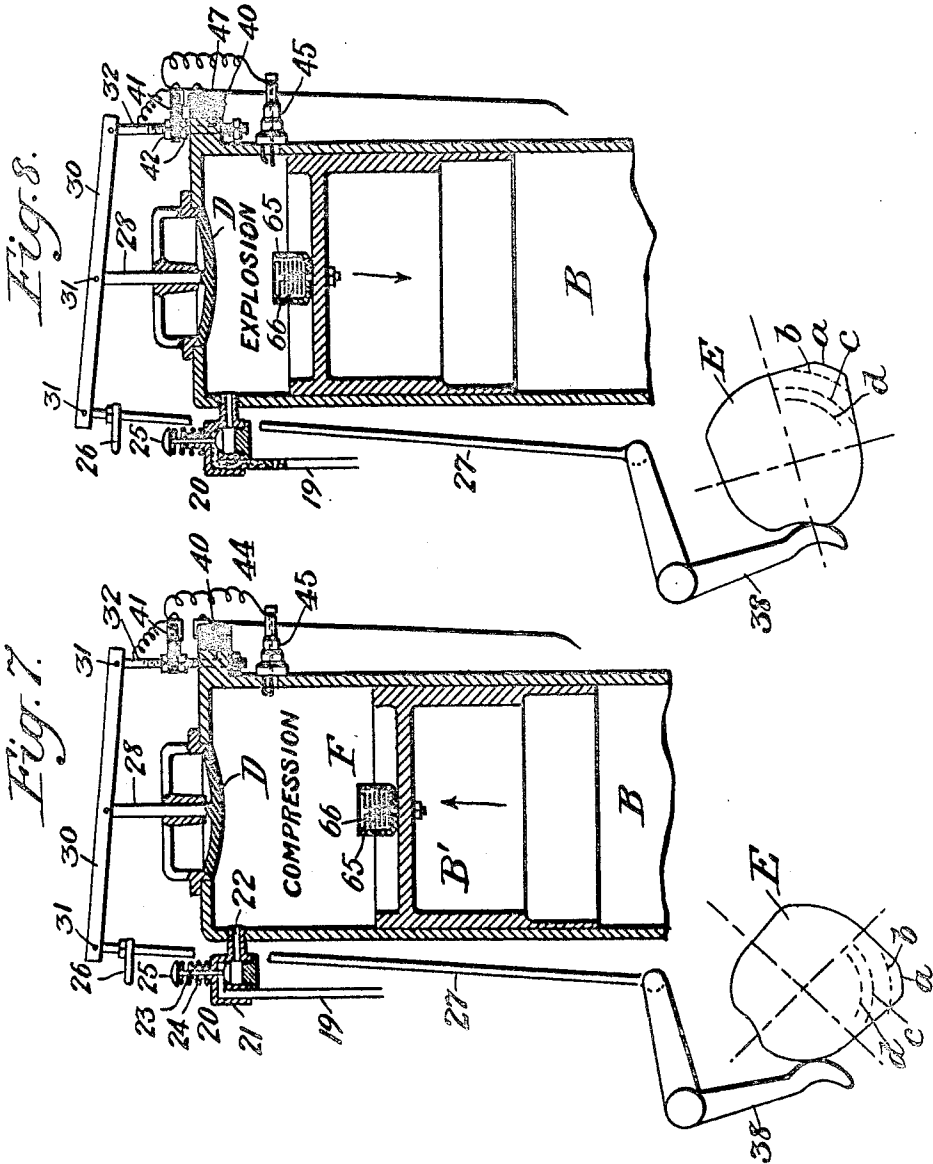

Witnesses:
 D. W. Edelin.
 J. H. Rockness

Inventor:
 F. O. Farwell
 by E. H. Johnson, atty.

F. O. FARWELL.
INTERNAL COMBUSTION MOTOR.
APPLICATION FILED FEB. 28, 1911.

1,155,138.

Patented Sept. 28, 1915.
6 SHEETS—SHEET 6.

Fig. 9.

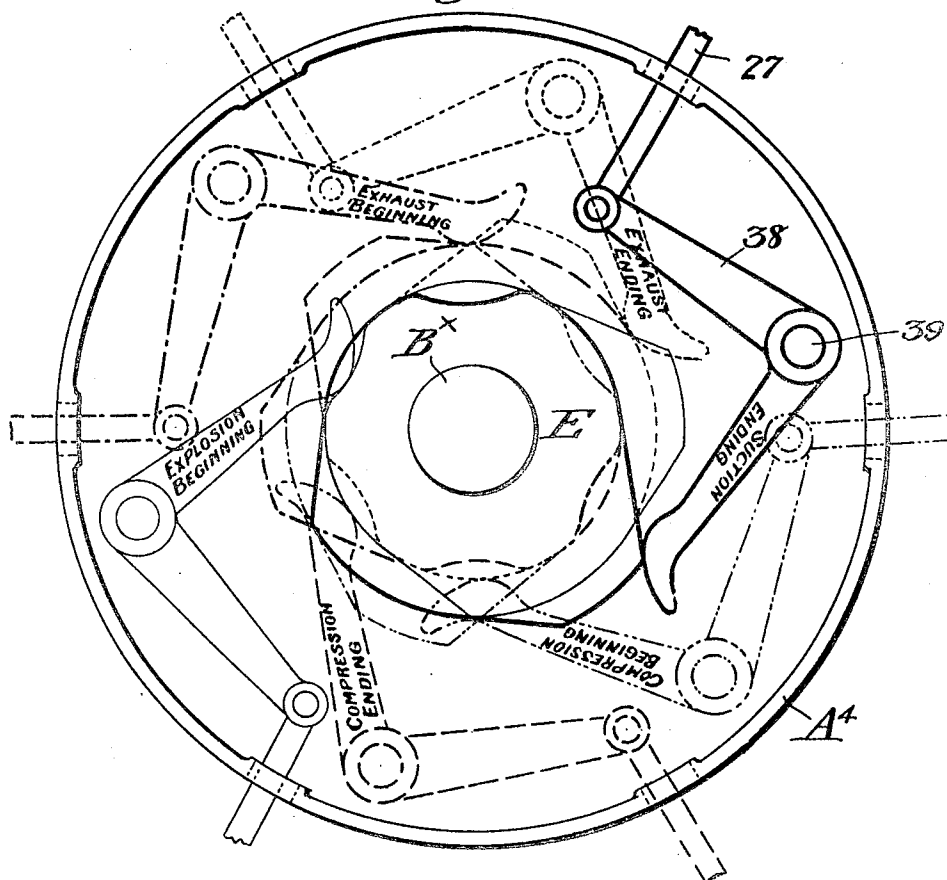

Witnesses:

D. W. Ellin

J. E. Rockness

Inventor:

Fay O. Farwell

By Lewis Goldsmith Hill
Attorney

UNITED STATES PATENT OFFICE.

FAY O. FARWELL, OF DUBUQUE, IOWA.

INTERNAL-COMBUSTION MOTOR.

1,155,138.

Specification of Letters Patent. Patented Sept. 28, 1915.

Application filed February 28, 1911. Serial No. 611,342.

To all whom it may concern:

Be it known that I, FAY O. FARWELL, a citizen of the United States, and resident of Dubuque, county of Dubuque, and State of Iowa, have invented certain new and useful Improvements in Internal-Combustion Motors; and I do hereby declare the following to be a full, clear, and exact description of the invention, such as will enable others skilled in the art to which it appertains to make and use the same.

This invention relates to internal combustion motors and has for its principal object the provision of a motor capable of delivering continuously a high power per unit of weight.

The invention refers more especially to motors for aerial and water craft, such as aeroplanes and motor boats, and the improved motor is of that general type in which a plurality of cylinders radiate from a central crank case and revolve with the casing around a central axis, which is constituted by the crank shaft. Motors of this type are shown in my Patents Nos. 806,125 and 831,048, dated December 5, 1905 and September 18, 1906, respectively, and in my pending application, Serial Number 606,177, filed February 2, 1911.

In motors used for the propulsion of aerial craft and racing motor boats, the maximum power is required for long periods, and therefore a continuously large volume of fuel, *i. e.* gaseous mixture must be supplied uniformly and without variation. The production of this large power output from a given cylinder area and weight necessitates a high piston speed, and piston speeds of from eighteen hundred to two thousand feet per minute are entirely practical. Under such conditions the admission of full charges of air and of the explosive mixture obviously requires a large inlet valve and unrestricted passage of the charge, and it is manifestly just as important to provide a large exhaust valve and unrestricted passage for the spent gases.

In the usual types of motors two valves are employed in connection with each cylinder, one to admit the charge and one to let out the exhaust gases. These valves, however, are of altogether insufficient size for the above purposes, as it is impossible to so arrange two sufficiently large valves within the area of the cylinder head that they will function properly. Valve pockets or en-

largements on the side of the cylinder, to admit of the use of larger valves, are not only inefficient but also highly objectionable by reason of their liability to collect carbon and other deposits. This disadvantage of the usual types of internal combustion motors, together with the restriction of the inflowing charge which is afforded by the usual manifold pipes and carbureter, unduly limits the charge and therefore the speed and power of such motors under full load conditions, with the result that the efficiency of the motor is relatively small. These motors will, of course, produce a high speed and a small power output such as would be sufficient for automobile use, but they do not produce a maximum power output with high speed because of their inability to take in a full charge at high speeds.

Under these circumstances, one of the objects of the present invention is to overcome these draw-backs and to produce a motor having ample means to let out the exhaust at high speeds and to admit full charges of air and fuel under the same conditions.

Another object which I have in view is a marked improvement in the power regulation of motors of this type, especially with a view to high economy of fuel when the motor is run below its maximum power output. While it is essential that the motor be capable of delivering its maximum power for long periods, as where it is used to propel an aerial craft, for example, it is also very desirable that the motor be economical in the use of fuel when its maximum power output is not employed.

There are two systems in general use for regulating the power of hydrocarbon motors. The system of throttling the charge, which prevents the cylinder from receiving a full charge, is not economical by reason of the vacuum created in the cylinder on the suction stroke. It is also especially objectionable on revolving cylinder motors inasmuch as the aforesaid vacuum draws the lubricating oil past the piston which is difficult to lubricate at best owing to the throwing of the oil to the explosion side of the piston by centrifugal force. Another system or method of power regulating consists in the variation of the compression in the cylinder by holding the inlet valve open during a portion of the compression stroke. This system is less wasteful of fuel and does not

create an objectionable vacuum in the cylinder, but the charge is drawn into the cylinder in a thoroughly mixed gaseous or carbureted form, and a charge with an excess of air cannot be ignited.

According to the present invention I do away with all of these objectionable features while admitting at all times a full charge of air to the cylinder. This charge is always compressed to the full compression pressure. These results are obtained by admitting fuel into the cylinder in a liquid form independent of the air, and this liquid is thrown against the head of the revolving cylinder by centrifugal force. During the suction and compression strokes, enough of the liquid fuel is gasified and mixed with air to form an explosive mixture with a part only of the cylinder content of air, and as the resulting gas is heavier than air it is held in the head of the cylinder by centrifugal force, where it surrounds the electrical ignition devices on the cylinder. During the explosion or power stroke the remainder of the liquid fuel is gasified and mixed with air and combustion is completed. It will therefore be seen that a small quantity of fuel may be consumed in an excess of air, and that this system is therefore very economical in the use of fuel when the engine runs at a low power output.

A still further object of the invention is the provision of an improved means for supplying and uniformly distributing the fuel charge to the respective cylinders of an engine of this type. The system of injecting liquid fuel directly into the cylinders some time after the exhaust stroke and before or during the explosion stroke, is used in various forms, but such motors in practice are limited mostly to large moderate speed motors in which the quantity of liquid fuel used on each explosion stroke is considerable. Multiple cylinder motors and high speed motors have been unsuccessful, however, because of the difficulty of delivering to each cylinder small equal quantities of liquid fuel. It will be readily understood that large quantities of liquid can be handled at moderate speeds by pumps and the like, but that small quantities cannot be pumped in exact and unvarying volumes at high speeds, for which reason the explosions in the several cylinders cannot be obtained in a uniform and reliable manner.

This disadvantage is obviated according to the present invention, which provides for the division and delivery of a very large number of fuel charges per minute to the several cylinders, which would be impossible with any pumping system. In order to obtain this result the centrifugal force induced by the rotation of the cylinders is utilized in the novel manner to be hereinafter explained.

The invention also provides an improved ignition system for motors of the type indicated, and it further consists in certain constructional or detail features of the motor, as will hereinafter appear.

In the accompanying drawing: Figure 1 is a side elevation of a motor embodying the invention, with a part of the supporting structure removed, Fig. 2 is a similar view from the opposite side of the engine; Fig. 3 is a horizontal section through the crank shaft, with certain parts omitted; Fig. 4 is an enlarged fragmentary view of one of the cylinders; Figs. 5, 6, 7 and 8 are vertical central sections of one of the cylinders, showing the four phases of operation, the valve controlling cam being shown at right angles to its true position; Fig. 9 is an enlarged face view of the cam mechanism, and Figs. 10 and 11 are details of the valve operating mechanism.

The motor comprises a central chamber or crank case A from which radiate a plurality of cylinders B. I have illustrated a six cylinder motor, but it will be understood that the number of cylinders is not essential. The crank case A is closed at the sides by cover plates A', A² each having an extension forming a bearing for the crank shaft and a bearing for a supporting frame such as A³ in which the cylinder and casing part of the motor is freely and rotatably mounted. The crank shaft is shown at B^x and it is suitably connected with the respective pistons B'.

Secured to the outer face of the cover plate A' is a cam casing A⁴, and on the outer face of said casing is a liquid fuel chamber C. This chamber is of annular form, concentric with the shaft and is provided at its outer face and near the center thereof with an annular inlet opening 15. Into this opening passes a fixed supply pipe 16 for the liquid fuel, said pipe being conveniently mounted on the supporting frame A³, as shown in Fig. 3, and having communication with a supply pipe 17 controlled by a regulating needle valve 18. The peripheral portion of the inlet fuel chamber is perforated equidistantly, corresponding to the location of the several cylinders, to afford communication with radially directed fuel distributing pipes 19 which lead to fuel inlet valves 20, of which one is associated with each cylinder near the head thereof. Each valve 20 preferably comprises a casing 21 having a branch 22 screwed into the side of the cylinder and directed laterally with respect to the same. Operating in the casing 21, which is suitably connected with the corresponding distributing pipe 19, is a valve proper, 23, which is normally urged upwardly by a spring 24 into its closed position, wherein it cuts off communication between the distributing pipe 19 and the inlet nozzle 22.

The spring 24 is interposed between the valve casing and a head 25 on the outer end of the valve stem.

The fuel admission valves 20 of the several cylinders are opened at the proper time by means of corresponding tappets 26 carried by rods 27 controlled by suitable cam mechanism in the cam case A', as will hereinafter appear. When a rod 27 is so actuated as to cause the engagement of the tappet 26 with the head 25 of the fuel inlet valve, such valve will be opened in opposition to its spring, as will be understood.

The rods 27, which extend alongside the respective cylinders and project radially out of the cam case A' are also used to operate combined air admission and exhaust valves D. Each valve is comparatively large and it is slidably mounted in the cylinder head. The upwardly directed stem 28 of said valve is provided at its outer extremity with a curved head 29 which extends within a tubular slotted cross rod 30. The valve stem 28 is pivotally connected with this tubular cross rod by means such as a cotter 31, as shown in Figs. 10 and 11, and the form of the head 29 is such as to permit the cross rod to fulcrum freely on the valve stem, to which it is connected intermediate of the ends of said rod. One of the ends of the cross rod is pivotally connected with the end of the corresponding valve operating rod 27 by means of a pivotal connection similar to that just described. The opposite end of the cross rod 30 is connected in the same way to a rod 32 which forms a part of the ignition mechanism, as will hereinafter appear. The rod 27, when properly controlled by the cam mechanism, not only actuates the fuel admission valve and the air admission and exhaust valve but it also operates this ignition mechanism.

In the embodiment shown the cam mechanism for controlling the movements of the respective rods 27 comprises a plurality of cams E in the cam case, one for each rod. These cams surround the bearing sleeve for the shaft at that side of the engine, and they are operated as a unit by means of a train of gears operated from the crank shaft. This train of gears comprises a gear 33, (Fig. 3) fixed on the crank shaft; a planetary gear 34 meshing with the gear 33 at a point within the crank case and rigidly connected with a planetary gear 35 within the cam case; and a gear 36 meshing with the gear 35 and fixed to a sleeve 37 rotatably mounted on the aforesaid bearing sleeve of the engine. The sleeve 37 carries the several cams E, which are grouped side by side and displaced angularly with respect to each other in the manner shown in Fig. 9. Bearing against each cam is an elbow lever 38 fulcrumed on a pin 39 fixed to the cover plate A'. One end of the elbow lever 38 is

suitably formed to contact with the cam while the opposite end is pivoted to the inner end of the corresponding valve operating rod 27. It will be readily understood that with the aforesaid arrangement of the gears and cams, the relative angular movement of the crank case and the crank shaft will result in an angular movement of the cam system with respect to the several elbow levers 38 on the cam case in order that the desired operations of the valve operating rods 27 may be obtained, as will hereinafter appear. Each cam has four radii *a, b, c, d*, which correspond with the different phases of the four-cycle operation. Of course the number of cams E is determined by the number of cylinders, although it will be understood that in some cases cams having different sets of contour may be employed, in which event the number of cams will be less than the number of cylinders.

The ignition mechanism employed is substantially as follows:—Each of the rods 32, which are pivoted to the ends of the cross rods 30 of the valve operating mechanism, passes freely through a lug 40 at the side of the corresponding cylinder head, which lug is preferably formed integral with the cylinder. Above said lug 40, as shown in Figs. 5 to 8, the rod 32 carries a block 41 of suitable insulating material, which block is adjustable longitudinally of the rod by means of nuts 42. The outward travel of the rod in the lug 40 is limited by an adjustable nut 43 on the inner or lower end of the rod. The insulating block 41 carries three separate metallic contacts or plates 41^a, 41^b, 41^c, which are arranged side by side at suitable intervals and each of which is furnished with a suitable terminal screw. The side contacts 41^a, 41^c are connected by means of wires 44 with spark plugs 45, 46, respectively, fitted in the wall of the cylinder at opposite sides of its longitudinal axis, as shown in Fig. 4. The intermediate contact 41^b is connected with the rod 32 or any other part of the motor on which it can be grounded. Arranged opposite the contacts 41^a, 41^b, 41^c are three similar contacts 47^a, 47^b, 47^c on an insulating block 47 on lug 40, these two sets of contacts being so located that when the rod 32 is depressed it will carry down the contacts on the block 41 into engagement with the respective contacts on the lug 40, thereby completing the electrical connections now to be described.

The fixed contacts 47^a, 47^b, 47^c are connected by means of corresponding wires or conductors 48^a, 48^b, 48^c, with corresponding contact rings 49^a, 49^b, 49^c, which are arranged concentrically and set in grooves in the outer face of an annular insulating member or ring 50 rotatable with the engine case. The insulating ring 50 is concentric with the shaft B and is prefer-

ably applied in any suitable manner to the cover plate A². Making contact with the several contact rings 49^a, 49^b, 49^c are suitable brushes 51^a, 51^b, 51^c, which may be appropriately mounted on an insulating block 52, conveniently arranged on the supporting frame A³, as shown in Figs. 2 and 3.

The brush 51^b may be connected by means of a wire 53 and switch 54 with a battery 55 which is connected at the opposite side by means of a wire 56 and switches 57, 58 with spark coils 59, 60, the battery circuit being completed by leads 61 and 61^a connected with the coils 59, 60 at one end and with the ground at the other end. The connection with the ground is preferably made by a terminal 62 on one bearing sleeve of the motor, as shown in Fig. 3. It will be understood, therefore, that the circuit 53, 55, 56, 61, 61^a which is in connection with the intermediate contact ring and the intermediate contacts 41^b, 47^b, is the primary ground circuit for the battery and is closed by the engagement of the two last mentioned contacts. The spark coils 59, 60 have their secondaries connected by means of leads 63, 64, respectively with the brushes 51^a and 51^c, and hence the two paths including the wires 48^a, 48^c, contacts 47^a, 47^c, contacts 41^a, 41^c and spark plugs 45, 46 are secondary leads for the respective spark plugs. These secondary leads are completed or closed by the engagement of the contacts 41^a, 47^a and by the contact of 41^c with 47^c, as will be understood. These secondary connections are therefore completed at the same time that the primary circuit is closed, and the closing of all three paths is effected by the movement of the contact block 41 on the rod 32, with respect to the fixed contact lug on the cylinder head.

The operation of an engine of this type is essentially as follows:—Liquid fuel is fed into the annular fuel chamber C by means of the supply pipe 16, the amount of fuel being properly regulated by the needle valve 18. If it is assumed that the motor is already in operation, and that the engine casing and cylinders are rotated as a unit, around the central crank shaft, it will be readily understood that the centrifugal force induced will cause the fuel entering by the pipe 16 to be thrown outward against the peripheral walls of the fuel chamber. From this point it is projected uniformly by the centrifugal force, in equal portions, to the fuel inlet valves 20 on the cylinder heads. It is a well known physical law that if a circular chamber or bowl be revolved rapidly and a quantity of liquid be introduced into the same, the liquid, through the influence of centrifugal force, will form a uniform film on the inner surface of the periphery of the revolving chamber. This same action takes place in the present instance, and

owing to the fact that the outlet holes of the fuel chamber are located equidistantly in the circumference of the chamber, the liquid will be projected out of the several holes in absolutely equal quantities. The valve casings 20 are therefore supplied uniformly with liquid fuel which backs up in the tubes or pipes 19 when the valves are closed, to an extent determined by the amount of the charge which, in turn, is determined by the adjustment of the single inlet valve 18.

Referring now to Figs. 5 to 8 inclusive, and particularly to Fig. 5, it will be seen that at the end of the power stroke the rod 27 through the pull of the elbow lever or bell crank 38 in passing from the radius *c* of its cam E to the radius *b*, will be moved inward. At the same time the cross rod or lever 30 will fulcrum at its pivotal connection 31 with the rod 32, thereby opening the combined exhaust and air inlet valve D and letting out the exhaust gases. At this time the movable contacts of the ignition mechanism are raised out of operative position and the fuel admission valve 20 being closed, the fuel projected outwardly in the radial fuel pipe 19 will back up or accumulate in that portion of the fuel pipe which is adjacent said valve. The air inlet and exhaust valve D will remain in the position shown in Fig. 5 during the entire exhaust stroke and part of the suction stroke, whereupon the bell crank 38 in passing from the radius *b* to the radius *a* of its cam will move the rod 27 inward still farther, together with the air inlet and exhaust valve, as shown in Fig. 6. During the continuance of the suction stroke, in which a full supply of air is admitted to the cylinder by way of the large valve D, the arm or tappet 26 on the rod 27 will contact with the head 25 of the fuel admission valve 20 and thereby open said valve in the manner hereinbefore explained, with the result that all of the liquid that had accumulated in the valve and supply pipe during the proceeding compression, explosion and exhaust strokes is admitted into the cylinder head. At the end of the suction stroke the bell crank 38 will have dropped back from radius *a* to radius *c*, permitting the rod 27 to move outward by centrifugal force. This results in the closing of the valve D and also the closing of the fuel valve, as shown in Fig. 7. The compression stroke then takes place, and the parts retain the position indicated until said stroke is nearly completed, at which time the bell crank will drop from radius *c* to radius *d*. The rod 27 will therefore be moved outward still farther by centrifugal force and the lever 30 will fulcrum on the valve stem 28, which is rigidly held in its outward position by the compression in the cylinder, as will be understood. The resulting movement of the lever 30 will therefore move the contact

block 41 into proximity to the insulating block 47 on the fixed lug 40, as shown in Fig. 8, whereby the opposing contacts are engaged with each other. This causes the grounding of the battery circuit through the primary contacts, as previously described, and as the battery circuit is now completed through the spark coils 59, 60 a secondary current will pass through each of said coils to the respective spark plug by way of the corresponding secondary path and its set of contacts, as hereinbefore explained, whereby the charge is fired. The four phases of the four-cycle operation are then repeated. In the case of the six cylinder motor illustrated, the phases of the respective cylinders bear the relation indicated in Fig. 1. The power is regulated solely by the adjustment of the fuel valve 18.

It will be readily understood from the foregoing description that the fuel charges are at all times supplied to the cylinders in a positive, efficient and unrestricted manner, irrespective of the speed attained. The air supply to the cylinders and the exhaust are also just as thorough at high speeds as at moderate speeds, owing to the provision of the large valves D and the means for operating them in a reliable manner. Full charges of air, compressed to the full compression pressure are always used, and during the suction and compression strokes enough of the fuel thrown against the head of the revolving cylinder is vaporized to form an explosive mixture with a part of the air content of the cylinder. As this vapor or gas is heavier than the air it is held in the head of the cylinder by centrifugal force, where it is immediately adjacent the spark plugs. During the explosion or power stroke the rest of the liquid fuel charge is vaporized and during this stroke the combustion is completed. It will, therefore, be evident that the power stroke differs from that in a motor using a carbureted charge, in that the initial pressure is lower, although on the other hand the pressure is sustained for a longer part of the power stroke. The combustion has an increasing expanding rather than an explosive effect. It will be readily understood that if the relatively small quantity of fuel fed to the cylinder were thoroughly mixed with the entire volume of air in the cylinder the gas produced would be too weak to ignite, but the present system obviates this disadvantage by utilizing the centrifugal force to keep the fuel in the cylinder head where it is separate from the greater part of the air content of the cylinder. Consequently, very small fuel charges can be consumed in an excess of air, with a resulting increase in the economy of fuel when less than maximum power is used.

The two spark plugs and the two secondary circuits are employed to make ignition

doubly sure. Either spark coil or either plug might fail and yet a spark would be produced from one plug. This feature is obviously of considerable importance where the motor is used on aeroplanes, for instance, under which circumstances the reliable operation of the ignition system is a matter of the greatest concern. However, although I have shown two spark plugs associated with each cylinder it is obvious that the number may be varied as required by circumstances. Other arrangements of the wiring may also be resorted to without departing from the invention. For instance, a magneto could be substituted for one of the spark coils, or the battery could be continuously grounded, causing the coils to produce a continuous stream of sparks. In this latter case the primary circuit could be disconnected or could be used to supply a third secondary current to a third plug if desired, and the secondary currents would pass only to the cylinder ready to be fired and whose contact blocks 41 and 47 were in a contact-making position.

In addition to the ignition system just described I may use an automatic igniter which may be employed in connection with the electrical ignition means or may be used by itself after the motor has been run for a certain length of time. This automatic igniter consists of a metal ignition device applied in a convenient manner to the explosive side of the piston. This device preferably comprises an outer cup-shaped casing, as best shown in Figs. 5 to 9, said casing being provided interiorly with a plurality of disks of some suitable heat-retaining metal. During the power stroke the whole device becomes highly heated by the burning charge. During the exhaust and suction strokes the outer casing becomes chilled below the igniting point, but the disks are so protected by the casing as to retain sufficient heat to ignite the explosive mixture. After the motor has been in operation for some time the disks will have gradually become so highly heated that when the ignition device is thrust into the gaseous mixture held in the head of the cylinder by centrifugal force, it will ignite such mixture. The retention of the explosive mixture in the cylinder head is therefore of great importance in this case also, as the automatic igniter is not brought into close proximity with the fuel except when the igniter approaches the cylinder head near the end of the compression stroke, *i. e.*, at the proper firing point. It is obvious that this would not occur if the liquid fuel were carbureted and entered the cylinder as an explosive mixture, for if the automatic igniter were sufficiently hot to fire the charge with certainty, it would fire it too early, or as soon as any of the intruding explosive charge came in contact with it.

The same thing would result in a stationary cylinder even if liquid fuel were injected, because of the absence of means such as centrifugal force to prevent the rapidly evaporating fuel from coming in contact with the highly heated igniter, before the end of the compression stroke.

It will be evident that the fuel distribution system, the combustion of the fuel in excess of air and the automatic ignition system all necessitate the rotation of cylinders around a central axis, and that this is also required by the arrangement of the contact rings of the electric ignition on the casing in combination with the fixed brushes hereinbefore described. However, the crank shaft may be rotatable or stationary, as desired. I prefer to use a motor in which the cylinders rotate at a moderate speed in one direction and the crank shaft rotates at a higher speed in the opposite direction. Although the employment of a fixed crank shaft is practicable it entails several disadvantages which do not occur in my preferred arrangement. For instance, if the most efficient piston speed is to be obtained the casing and cylinders will have to be rotated at a high speed and this will necessitate much greater weight and strength in the cylinders, connecting rods, flanges and fastenings to withstand the greater strains of centrifugal force, which is quadrupled as the speed is doubled. The high rotative speed of the cylinders is also prejudicial to lubrication because the greater centrifugal force throws the oil outward and past the pistons without properly lubricating the latter. Again, the excellent cooling effect produced by rotating the cylinders at a moderate speed is greatly lessened when the cylinders are given a high speed because the atmospheric pressure is not sufficient to force fresh air in contact with the rear sides of the cylinders, which will therefore become overheated.

Of course the specific arrangement of the valve operating levers 38 does not affect the broader aspects of the invention, but the pivotal connection of the valve operating rod 27, the valve stem 28 and the contact carrying rod 32 to a tubular lever in the manner described provides a very strong light and durable construction. The tubular lever need only be slotted sufficiently to make the necessary connections, as will be understood. The pull of the rods 27 and 32 and of the valve stem 28 is brought directly upon the tubular lever by the curved or oval shaped heads 29 in contact with the inner surface of the latter.

It will be understood that although I have described in detail the preferred embodiment of the invention shown in the drawing I have not attempted to describe the numerous modifications of the construction which may be adopted without departing

from the scope of the invention as defined in the claims.

What I claim is:—

1. In an internal combustion motor, cylinders radiating from and rotatable about a central axis, liquid fuel inlet valves on the respective cylinders, a circular liquid fuel chamber concentric with the rotary axis of the cylinders and movable with the latter, and pipes connecting said chamber with the respective fuel valves. 70
2. In an internal combustion motor, cylinders rotatable about a central axis, a central liquid fuel chamber movable with the cylinders, fuel inlet valves on the respective cylinders and connected with said fuel chamber for supply of liquid fuel therefrom, and means for operating said valves. 75
3. The combination with a rotary motor casing and cylinders radiating therefrom, of a liquid fuel chamber of annular form applied to one face of said casing concentric with the axis of rotation of the latter, liquid fuel inlet valves on the outer ends of the cylinders and having individual connections with said fuel chamber into which the fuel is projected by centrifugal force, and means for operating said valves. 80
4. The combination with a rotary crank case and cylinders radiating therefrom, of a circular fuel chamber applied to one side of the crank case and having an opening in its outer face, a fixed liquid fuel supply pipe to inject fuel into said opening and into said chamber, fuel inlet valves on the outer ends of the respective cylinders, and radial pipes extending alongside the respective cylinders and connecting the fuel chamber with the respective inlet valves, said pipes adapted to conduct the liquid fuel from said fuel chamber to said inlet valves. 85
5. The combination with a rotary crank case of a motor, and a plurality of cylinders radiating therefrom, of a rotary fuel supply casing carried by the crank case and into which liquid fuel is fed in regulable quantities, a fixed pipe to feed said fuel to the said rotary casing, normally closed fuel inlet valves on the cylinders, pipes connecting said valves with said fuel casing and adapted to conduct the liquid fuel from said fuel casing to the valves, and means to open said valves periodically. 90
6. In an internal combustion motor, the combination of cylinders rotatable about a central axis, normally closed fuel admission valves on the respective cylinders, air inlet valves associated with said cylinders, a central crank shaft, cam mechanism associated with said crank shaft, and valve operating rods controlled by said cam mechanism adapted to cause both valves to remain open for part of the same cycle of operation. 95
7. In an internal combustion motor, the combination of a plurality of cylinders rota- 100

table about a central axis, a central crank shaft, a combined air admission and exhaust valve of relatively large area located in the head of each cylinder, a fuel admission valve in each cylinder, cam mechanism associated with the crank shaft, and valve operating rods controlled by said cam mechanism and connected with said valves to operate the same, to cause the air inlet and exhaust valve only to remain open during the exhaust stroke and both valves to remain open during part of the suction stroke.

8. In an internal combustion motor, the combination of a plurality of cylinders rotatable about a central axis, a central crank shaft, a combined air inlet and exhaust valve of large area in the head of each cylinder, a fuel admission valve in the side of each cylinder, means to supply fuel to said last named valves, and cam mechanism associated with the crank shaft and connected with said valves to operate the same to cause the air inlet and exhaust valve only to remain open during the exhaust stroke and both valves to remain open during part of the suction stroke.

9. In an internal combustion motor, the combination of cylinders mounted for rotation about a single axis, a crank shaft connected with the pistons of said cylinders, a combined air admission and exhaust valve in the head of each cylinder, levers connected with the stems of said valves, valve operating rods connected with said levers, cam mechanism associated with the crank shaft to control said rods, normally closed fuel admission valves on the respective cylinders, and means carried by said rods to abut said fuel valves periodically and thereby open the same.

10. In an internal combustion motor of the type described, the combination of a central crank shaft, cylinders rotatable about the same, a fuel admission means in connection with each cylinder, air admission and exhaust means in connection with each cylinder, ignition means associated with each cylinder, and cam mechanism associated with the crank shaft and connected with all of the aforesaid means to operate the same, when the cylinders are rotated.

11. In an internal combustion motor, the combination of cylinders rotatable about a

single axis, a valve associated with each cylinder, cam controlled valve operating rods, ignition means on each of the cylinders comprising contact devices operated by said valve operating rods, a primary ignition circuit, and secondary ignition connections connected with said contact devices.

12. In an internal combustion motor, the combination of cylinders rotatable about a single axis and having valves, valve operating rods associated with the respective cylinders, a plurality of ignition devices in connection with each cylinder, said devices comprising contact devices operated by said valve operating rods, a primary ignition circuit, and secondary ignition connections connected with the contact devices.

13. In an internal combustion motor, the combination of a plurality of cylinders rotatable about a common axis and each provided with a combined air inlet and exhaust valve, cam controlled rods to operate said valves, contact devices operated by said rods, a plurality of spark plugs associated with each cylinder, and secondary current connections connected with said plugs and with said contact devices.

14. In an internal combustion motor, the combination of a plurality of cylinders rotatable about a common axis, cam controlled rods associated with the respective cylinders, contact devices operated by each rod, an ignition device on each cylinder, a primary ignition circuit, and secondary circuit connections connected with said ignition device, and said contact device.

15. In an internal combustion motor, the combination of a plurality of cylinders rotatable about a common axis, a cam controlled rod associated with each cylinder, an ignition device associated with each cylinder, a contact device operated by each of said rods, and a secondary current supply connected with each contact device and each ignition device and including a contact ring on the motor casing and a relatively fixed brush coacting with said ring.

In testimony whereof I affix my signature, in presence of two witnesses.

FAY O. FARWELL.

Witnesses:

RAY S. FARWELL,
R. W. BOSSHART.