



(19) **United States**

(12) **Patent Application Publication**

**Aspnes et al.**

(10) **Pub. No.: US 2001/0046049 A1**

(43) **Pub. Date: Nov. 29, 2001**

(54) **THIN FILM OPTICAL MEASUREMENT SYSTEM AND METHOD WITH CALIBRATING ELLIPSOMETER**

(76) Inventors: **David E. Aspnes**, Apex, NC (US); **Jon Opsal**, Livermore, CA (US); **Jeffrey T. Fanton**, Los Altos, CA (US)

Correspondence Address:  
**STALLMAN & POLLOCK LLP**  
**Suite 290**  
**121 Spear Street**  
**San Francisco, CA 94105 (US)**

(21) Appl. No.: **09/886,514**

(22) Filed: **Jun. 21, 2001**

**Related U.S. Application Data**

(63) Continuation of application No. 09/247,121, filed on Feb. 8, 1999, which is a continuation of application No. 09/098,880, filed on Jun. 17, 1998, now Pat. No. 5,900,939, which is a continuation of application No. 08/890,697, filed on Jul. 11, 1997, now Pat. No. 5,798,837.

**Publication Classification**

(51) **Int. Cl.<sup>7</sup> ..... G01J 4/00**

(52) **U.S. Cl. .... 356/369**

(57) **ABSTRACT**

An optical measurement system for evaluating a reference sample that has at least a partially known composition. The optical measurement system includes a reference ellipsometer and at least one non-contact optical measurement device. The reference ellipsometer includes a light generator, an analyzer and a detector. The light generator generates a beam of quasi-monochromatic light having a known wavelength and a known polarization for interacting with the reference sample. The beam is directed at a non-normal angle of incidence relative to the reference sample to interact with the reference sample. The analyzer creates interference between the S and P polarized components in the light beam after the light beam has interacted with reference sample. The detector measures the intensity of the light beam after it has passed through the analyzer. A processor determines the polarization state of the light beam entering the analyzer from the intensity measured by the detector, and determines an optical property of the reference sample based upon the determined polarization state, the known wavelength of light from the light generator and the composition of the reference sample. The processor also operates the optical measurement device to measure an optical parameter of the reference sample. The processor calibrates the optical measurement device by comparing the measured optical parameter from the optical measurement device to the determined optical property from the reference ellipsometer.

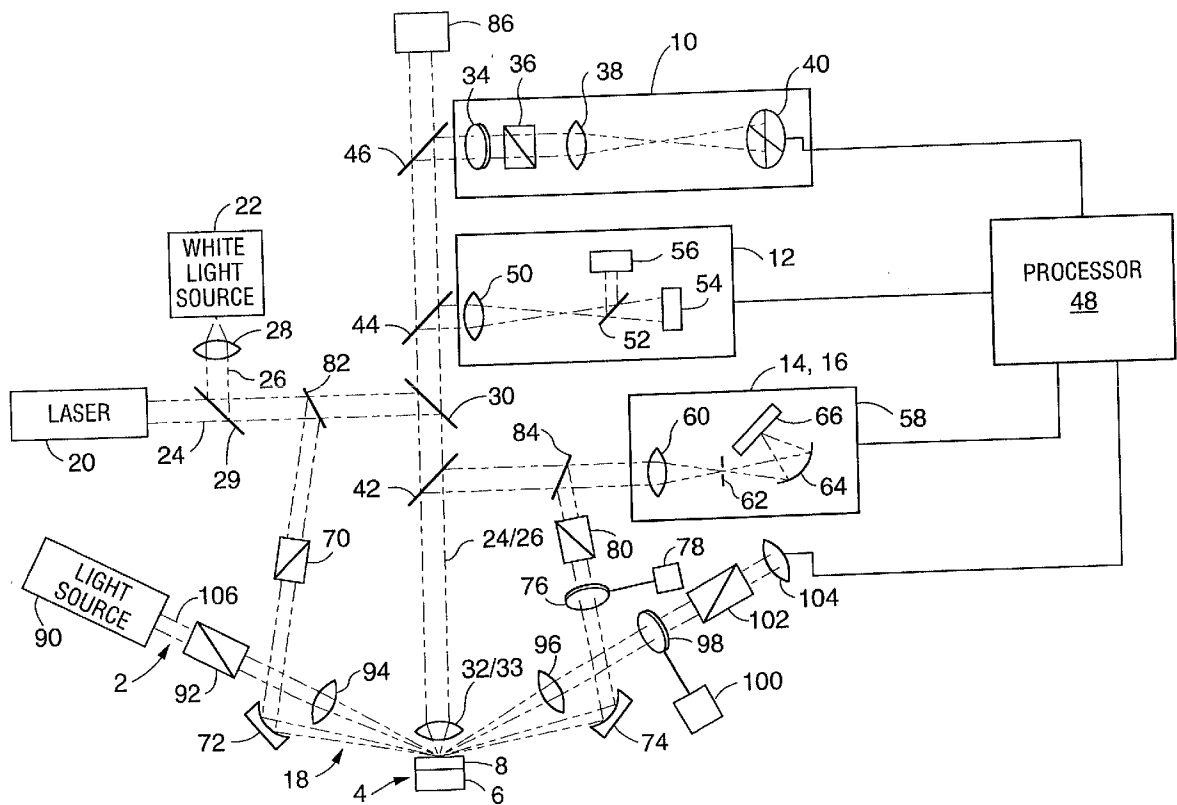



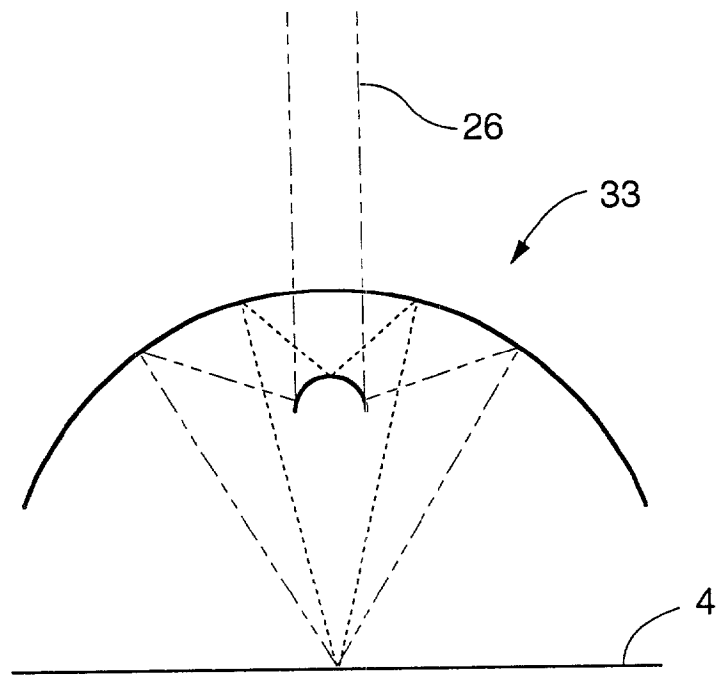

**FIG. 2**

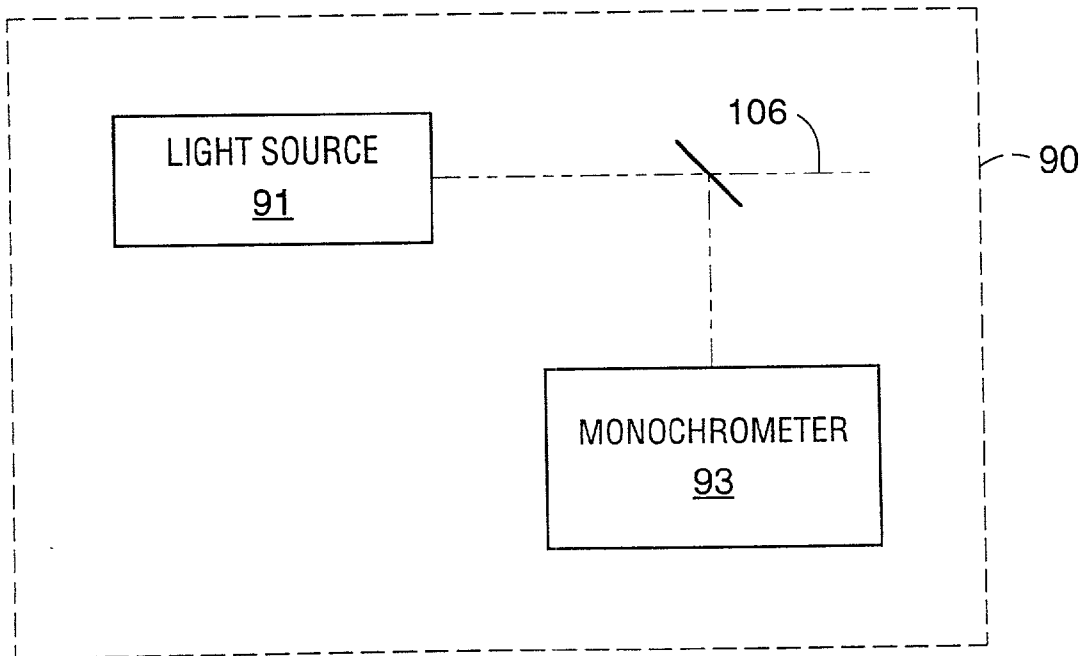

**FIG. 3**

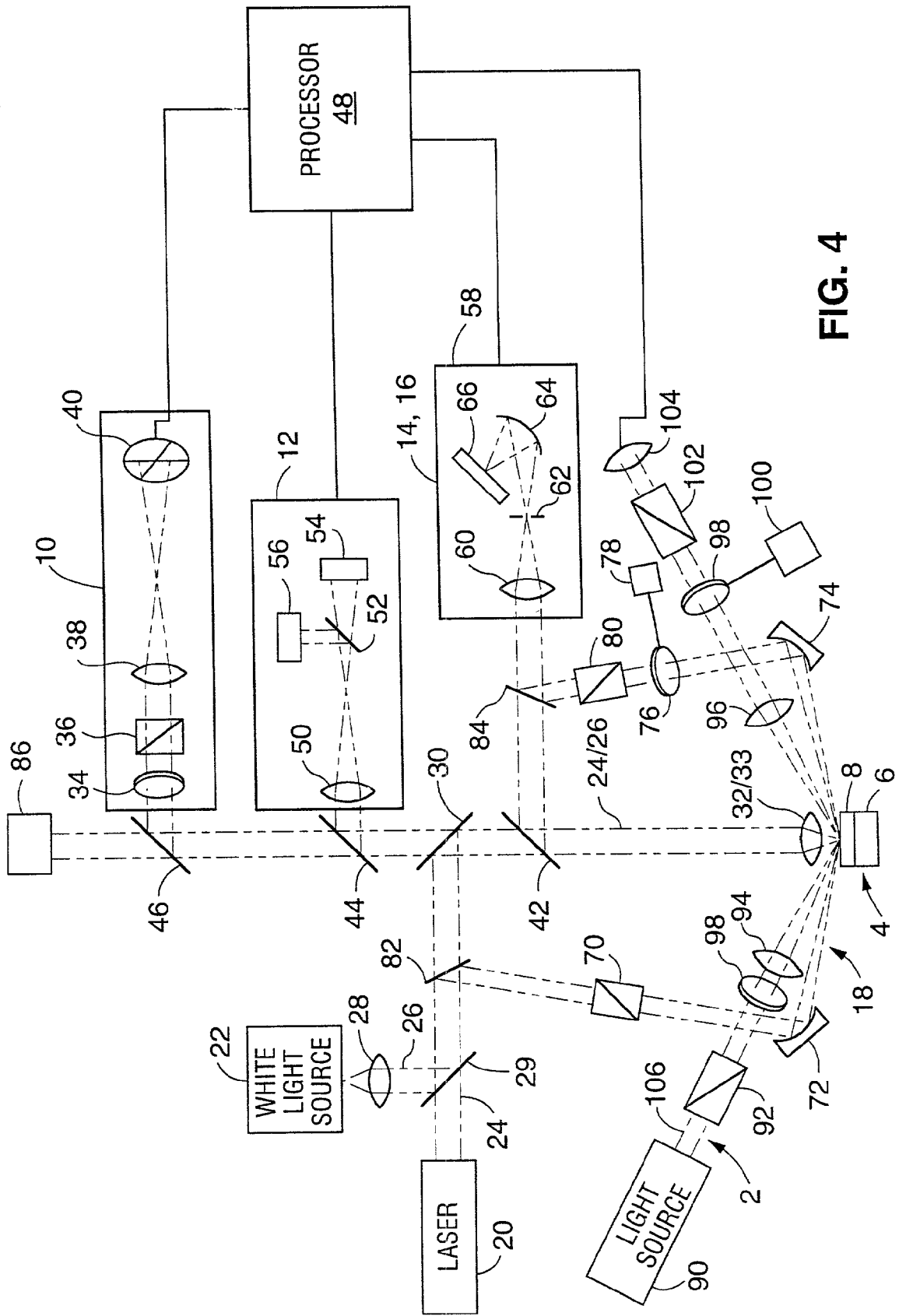

FIG. 4

## THIN FILM OPTICAL MEASUREMENT SYSTEM AND METHOD WITH CALIBRATING ELLIPSOMETER

### FIELD OF THE INVENTION

[0001] The present invention relates to optical analyzers, and more particularly to a thin film optical measurement system having a calibrating ellipsometer.

### BACKGROUND OF THE INVENTION

[0002] There is considerable interest in developing systems for accurately measuring the thickness and/or composition of thin films. The need is particularly acute in the semiconductor manufacturing industry where the thickness of these thin film oxide layers on semiconductor substrates is measured. To be useful, the measurement system must be able to determine the thickness and/or composition of films with a high degree of accuracy. The preferred measurement systems rely on non-contact, optical measurement techniques, which can be performed during the semiconductor manufacturing process without damaging the wafer sample. Such optical measurement techniques include directing a probe beam to the sample, and measuring one or more optical parameters of the reflected probe beam.

[0003] In order to increase measurement accuracy and to gain additional information about the target sample, multiple optical measuring devices are incorporated into a single composite optical measurement system. For example, the present assignee has marketed a product called OPTI-PROBE, which incorporates several optical measurement devices, including a Beam Profile Reflectometer (BPR), a Beam Profile Ellipsometer (BPE), and a Broadband Reflective Spectrometer (BRS). Each of these devices measures parameters of optical beams reflected by, or transmitted through, the target sample. The BPR and BPE devices utilize technology described in U.S. Pat. Nos. 4,999,014 and 5,181,080 respectively, which are incorporated herein by reference.

[0004] The composite measurement system mentioned above combines the measured results of each of the measurement devices to precisely derive the thickness and composition of the thin film and substrate of the target sample. However, the accuracy of the measured results depends upon precise initial and periodic calibration of the measurement devices in the optical measurement system. Further, recently developed measurement devices have increased sensitivity to more accurately measure thinner films and provide additional information about film and substrate composition. These newer systems require very accurate initial calibration. Further, heat, contamination, optical damage, alignment, etc., that can occur over time in optical measurement devices, affect the accuracy of the measured results. Therefore, periodic calibration is necessary to maintain the accuracy of the composite optical measurement system.

[0005] It is known to calibrate optical measurement devices by providing a reference sample having a known substrate, with a thin film thereon having a known composition and thickness. The reference sample is placed in the measurement system, and each optical measurement device measures the optical parameters of the reference sample, and is calibrated using the results from the reference sample and

comparing them to the known film thickness and composition. A common reference sample is a "native oxide" reference sample, which is a silicon substrate with an oxide layer formed thereon having a known thickness (about 20 angstroms). After fabrication, the reference sample is kept in a non-oxygen environment to minimize any further oxidation and contamination that changes the thickness of the reference sample film away from the known thickness, and thus reduces the effectiveness of the reference sample for accurate calibration. The same reference sample can be reused to periodically calibrate the measurement system. However, if and when the amount of oxidation or contamination of the reference sample changes the film thickness significantly from the known thickness, the reference sample must be discarded.

[0006] For many optical measurement devices, reference samples with known thicknesses have been effective for system calibration. Oxidation and contamination that routinely occurs over time with reference samples is tolerable because the film thickness change resulting from the oxidation/contamination is relatively insignificant compared to the overall thickness of the film (around 100 angstroms). However, new ultra-sensitive optical measurement systems have been recently developed that can measure film layers with thicknesses less than 10 angstroms. These systems require reference samples having film thicknesses on the order of 20 angstroms for accurate calibration. For such thin film reference samples, however, the changes in film layer thickness resulting from even minimal oxidation or contamination are significant compared to the overall "known" film layer thickness, and result in significant calibration error. Therefore, it is extremely difficult, if not impossible, to provide a native oxide reference sample with a known thickness that is stable enough over time to be used for periodic calibration of ultra-sensitive optical measurement systems.

[0007] There is a need for a calibration method for ultra-sensitive optical measurement devices that can utilize a reference sample that does not have a stable or known film thickness.

### SUMMARY OF THE INVENTION

[0008] The present invention is a thin film optical measurement system with a wavelength stable calibration ellipsometer that precisely determines the thickness of a film on a reference sample. The measured results from the calibration ellipsometer are used to calibrate other optical measurement devices in the thin film optical measurement system. By not having to supply a reference sample with a predetermined known film thickness, a reference sample having a film with a known composition can be repeatedly used to calibrate ultra-sensitive optical measurement devices, even if oxidation or contamination of the reference sample changes the thickness of the film over time.

[0009] The calibration reference ellipsometer uses a reference sample that has at least a partially known composition to calibrate at least one other non-contact optical measurement device. The reference ellipsometer includes a light generator that generates a quasi-monochromatic beam of light having a known wavelength and a known polarization for interacting with the reference sample. The beam is directed at a non-normal angle of incidence relative to the

reference sample to interact with the reference sample. An analyzer creates interference between S and P polarized components in the light beam after the light beam has interacted with reference sample. A detector measures the intensity of the light after the beam has passed through the analyzer. A processor determines the polarization state of the light beam entering the analyzer from the intensity measured by the detector. The processor then determines optical properties of the reference sample based upon the determined polarization state, the known wavelength of light from the light generator and the at least partially known composition of the reference sample. Wherein the processor operates at least one other non-contact optical measurement device that measures an optical parameter of the reference sample. The processor calibrates the other optical measurement device by comparing the measured optical parameter from the other optical measurement device to the determined optical property from the reference ellipsometer.

[0010] Other aspects and features of the present invention will become apparent by a review of the specification, claims and appended figures.

#### BRIEF DESCRIPTION OF THE DRAWINGS

[0011] FIG. 1 is a plan view of a composite optical measurement system with the calibration ellipsometer of the present invention.

[0012] FIG. 2 is a side cross-sectional view of the reflective lens used with the present invention.

[0013] FIG. 3 is a plan view of an alternate embodiment of the light source for the calibration ellipsometer of the present invention.

[0014] FIG. 4 is a plan view of the composite optical measurement system with multiple compensators in the calibration ellipsometer of the present invention.

#### DETAILED DESCRIPTION OF THE PREFERRED EMBODIMENTS

[0015] The present invention is a composite thin film optical measurement system 1 having a wavelength stable reference ellipsometer 2 that is used, in conjunction with a reference sample 4 having a substrate 6 and thin film 8 with known compositions, to calibrate non-contact optical measurement devices contained in the composite thin film optical measurement system 1.

[0016] FIG. 1 illustrates the composite optical measurement system 1 that has been developed by the present assignees, which includes five different non-contact optical measurement devices and the reference ellipsometer 2 of the present invention.

[0017] Composite optical measurement system 1 includes a Beam Profile Ellipsometer (BPE) 10, a Beam Profile Reflectometer (BPR) 12, a Broadband Reflective Spectrometer (BRS) 14, a Deep Ultra Violet Reflective Spectrometer (DUV) 16, and a Broadband Spectroscopic Ellipsometer (BSE) 18. These five optical measurement devices utilize as few as two optical sources: laser 20 and white light source 22. Laser 20 generates a probe beam 24, and white light source 22 generates probe beam 26 (which is collimated by lens 28 and directed along the same path as probe beam 24 by mirror 29). Laser 20 ideally is a solid state laser diode

from Toshiba Corp. which emits a linearly polarized 3 mW beam at 673 nm. White light source 22 is ideally a deuterium-tungsten lamp that produces a 200 mW polychromatic beam that covers a spectrum of 200 nm to 800 nm. The probe beams 24/26 are reflected by mirror 30, and pass through mirror 42 to sample 4.

[0018] The probe beams 24/26 are focused onto the surface of the sample with a lens 32 or lens 33. In the preferred embodiment, two lenses 32/33 are mounted in a turret (not shown) and are alternatively movable into the path of probe beams 24/26. Lens 32 is a spherical, microscope objective lens with a high numerical aperture (on the order of 0.90 NA) to create a large spread of angles of incidence with respect to the sample surface, and to create a spot size of about one micron in diameter. Lens 33 is illustrated in FIG. 2, and is a reflective lens having a lower numerical aperture (on the order of 0.4 NA) and capable of focusing deep UV light to a spot size of about 10-15 microns.

[0019] Beam profile ellipsometry (BPE) is discussed in U.S. Pat. No. 5,181,080, issued Jan. 19, 1993, which is commonly owned by the present assignee and is incorporated herein by reference. BPE 10 includes a quarter wave plate 34, polarizer 36, lens 38 and a quad detector 40. In operation, linearly polarized probe beam 24 is focused onto sample 4 by lens 32. Light reflected from the sample surface passes up through lens 32, through mirrors 42, 30 and 44, and directed into BPE 10 by mirror 46. The position of the rays within the reflected probe beam correspond to specific angles of incidence with respect to the sample's surface. Quarter-wave plate 34 retards the phase of one of the polarization states of the beam by 90 degrees. Linear polarizer 36 causes the two polarization states of the beam to interfere with each other. For maximum signal, the axis of the polarizer 36 should be oriented at an angle of 45 degrees with respect to the fast and slow axis of the quarter-wave plate 34. Detector 40 is a quad-cell detector with four radially disposed quadrants that each intercept one quarter of the probe beam and generate a separate output signal proportional to the power of the portion of the probe beam striking that quadrant. The output signals from each quadrant are sent to a processor 48. As discussed in the U.S. Pat. No. 5,181,080, by monitoring the change in the polarization state of the beam, ellipsometric information, such as  $\psi$  and  $\Delta$ , can be determined. To determine this information, the processor 48 takes the difference between the sums of the output signals of diametrically opposed quadrants, a value which varies linearly with film thickness for very thin films.

[0020] Beam profile reflectometry (BPR) is discussed in U.S. Pat. No. 4,999,014, issued on Mar. 12, 1991, which is commonly owned by the present assignee and is incorporated herein by reference. BPR 12 includes a lens 50, beam splitter 52 and two linear detector arrays 54 and 56 to measure the reflectance of the sample. In operation, linearly polarized probe beam 24 is focused onto sample 4 by lens 32, with various rays within the beam striking the sample surface at a range of angles of incidence. Light reflected from the sample surface passes up through lens 32, through mirrors 42 and 30, and directed into BPR 12 by mirror 44. The position of the rays within the reflected probe beam correspond to specific angles of incidence with respect to the sample's surface. Lens 50 spatially spreads the beam two-dimensionally. Beam splitter 52 separates the S and P components of the beam, and detector arrays 54 and 56 are

oriented orthogonal to each other to isolate information about S and P polarized light. The higher angles of incidence rays will fall closer to the opposed ends of the arrays. The output from each element in the diode arrays will correspond to different angles of incidence. Detector arrays 54/56 measure the intensity across the reflected probe beam as a function of the angle of incidence with respect to the sample surface. The processor 48 receives the output of the detector arrays 54/56, and derives the thickness and refractive index of the thin film layer 8 based on these angular dependent intensity measurements by utilizing various types of modeling algorithms. Optimization routines which use iterative processes such as least square fitting routines are typically employed. One example of this type of optimization routine is described in "Multiparameter Measurements of Thin Films Using Beam-Profile Reflectivity," Fanton, et. al., Journal of Applied Physics, Vol. 73, No. 11, p.7035, 1993.

[0021] Broadband reflective spectrometer (BRS) 14 simultaneously probes the sample 4 with multiple wavelengths of light. BRS 14 uses lens 32 and includes a broadband spectrometer 58 which can be of any type commonly known and used in the prior art. The spectrometer 58 shown in FIG. 1 includes a lens 60, aperture 62, dispersive element 64 and detector array 66. During operation, probe beam 26 from white light source 22 is focused onto sample 4 by lens 32. Light reflected from the surface of the sample passes up through lens 32, and is directed by mirror 42 (through mirror 84) to spectrometer 58. The lens 60 focuses the probe beam through aperture 62, which defines a spot in the field of view on the sample surface to analyze. Dispersive element 64, such as a diffraction grating, prism or holographic plate, angularly disperses the beam as a function of wavelength to individual detector elements contained in the detector array 66. The different detector elements measure the optical intensities of the different wavelengths of light contained in the probe beam, preferably simultaneously. Alternately, detector 66 can be a CCD camera, or a photomultiplier with suitably dispersive or otherwise wavelength selective optics. It should be noted that a monochromator could be used to measure the different wavelengths serially (one wavelength at a time) using a single detector element. Further, dispersive element 64 can also be configured to disperse the light as a function of wavelength in one direction, and as a function of the angle of incidence with respect to the sample surface in an orthogonal direction, so that simultaneous measurements as a function of both wavelength and angle of incidence are possible. Processor 48 processes the intensity information measured by the detector array 66.

[0022] Deep ultra violet reflective spectrometry (DUV) simultaneously probes the sample with multiple wavelengths of ultra-violet light. DUV 16 uses the same spectrometer 58 to analyze probe beam 26 as BRS 14, except that DUV 16 uses the reflective lens 33 instead of focusing lens 32. To operate DUV 16, the turret containing lenses 32/33 is rotated so that reflective lens 33 is aligned in probe beam 26. The reflective lens 33 is necessary because solid objective lenses cannot sufficiently focus the UV light onto the sample.

[0023] Broadband spectroscopic ellipsometry (BSE) is discussed in pending U.S. patent application Ser. No. 08/685,606, filed on Jul. 24, 1996, which is commonly owned by the present assignee and is incorporated herein by

reference. BSE (18) includes a polarizer 70, focusing mirror 72, collimating mirror 74, rotating compensator 76, and analyzer 80. In operation, mirror 82 directs at least part of probe beam 26 to polarizer 70, which creates a known polarization state for the probe beam, preferably a linear polarization. Mirror 72 focuses the beam onto the sample surface at an oblique angle, ideally on the order of 70 degrees to the normal of the sample surface. Based upon well known ellipsometric principles, the reflected beam will generally have a mixed linear and circular polarization state after interacting with the sample, based upon the composition and thickness of the sample's film 8 and substrate 6. The reflected beam is collimated by mirror 74, which directs the beam to the rotating compensator 76. Compensator 76 introduces a relative phase delay  $\delta$  (phase retardation) between a pair of mutually orthogonal polarized optical beam components. Compensator 8 is rotated at an angular velocity  $\omega$  about an axis substantially parallel to the propagation direction of the beam, preferably by an electric motor 78. Analyzer 80, preferably another linear polarizer, mixes the polarization states incident on it. By measuring the light transmitted by analyzer 80, the polarization state of the reflected probe beam can be determined. Mirror 84 directs the beam to spectrometer 58, which simultaneously measures the intensities of the different wavelengths of light in the reflected probe beam that pass through the compensator/analyzer combination. Processor 48 receives the output of the detector 66, and processes the intensity information measured by the detector 66 as a function of wavelength and as a function of the azimuth (rotational) angle of the compensator 76 about its axis of rotation, to solve the ellipsometric values  $\psi$  and  $\Delta$  as described in U.S. patent application Ser. No. 08/685,606.

[0024] Detector/camera 86 is positioned above mirror 46, and can be used to view reflected beams off of the sample 4 for alignment and focus purposes.

[0025] In order to calibrate BPE 10, BPR 12, BRS 14, DUV 16, and BSE 18, the composite optical measurement system 1 includes the wavelength stable calibration reference ellipsometer 2 used in conjunction with a reference sample 4. Ellipsometer 2 includes a light source 90, polarizer 92, lenses 94 and 96, rotating compensator 98, analyzer 102 and detector 104.

[0026] Light source 90 produces a quasi-monochromatic probe beam 106 having a known stable wavelength and stable intensity. This can be done passively, where light source 90 generates a very stable output wavelength which does not vary over time (i.e. varies less than 1%). Examples of passively stable light sources are a helium-neon laser, or other gas discharge laser systems. Alternately, a non-passive system can be used as illustrated in FIG. 3 where the light source 90 includes a light generator 91 that produces light having a wavelength that is not precisely known or stable over time, and a monochromator 93 that precisely measures the wavelength of light produced by light generator 91. Examples of such light generators include laser diodes, or polychromatic light sources used in conjunction with a color filter such as a grating. In either case, the wavelength of beam 106, which is a known constant or measured by monochromator 93, is provided to processor 48 so that ellipsometer 2 can accurately calibrate the optical measurement devices in system 1.

[0027] The beam 106 interacts with polarizer 92 to create a known polarization state. In the preferred embodiment, polarizer 92 is a linear polarizer made from a quartz Rochon prism, but in general the polarization does not necessarily have to be linear, nor even complete. Polarizer 92 can also be made from calcite. The azimuth angle of polarizer 92 is oriented so that the plane of the electric vector associated with the linearly polarized beam exiting from the polarizer 92 is at a known angle with respect to the plane of incidence (defined by the propagation direction of the beam 106 and the normal to the surface of sample 4). The azimuth angle is preferably selected to be on the order of 30 degrees because the sensitivity is optimized when the reflected intensities of the P and S polarized components are approximately balanced. It should be noted that polarizer 92 can be omitted if the light source 90 emits light with the desired known polarization state.

[0028] The beam 106 is focused onto the sample 4 by lens 94 at an oblique angle. For calibration purposes, reference sample 4 ideally consists of a thin oxide layer 8 having a thickness  $d$ , formed on a silicon substrate 6. However, in general, the sample 4 can be any appropriate substrate of known composition, including a bare silicon wafer, and silicon wafer substrates having one or more thin films thereon. The thickness  $d$  of the layer 8 need not be known, or be consistent between periodic calibrations. The useful light from probe beam 106 is the light reflected by the sample 4 symmetrically to the incident beam about the normal to the sample surface. It is noted however that the polarization state of nonspecularly scattered radiation can be determined by the method of the present invention as well. The beam 106 is ideally incident on sample 4 at an angle on the order of 70 degrees to the normal of the sample surface because sensitivity to sample properties is maximized in the vicinity of the Brewster or pseudo-Brewster angle of a material. Based upon well known ellipsometric principles, the reflected beam will generally have a mixed linear and circular polarization state after interacting with the sample, as compared to the linear polarization state of the incoming beam. Lens 96 collimates beam 106 after its reflection off of the sample 4.

[0029] The beam 106 then passes through the rotating compensator (retarder) 98, which introduces a relative phase delay  $\delta$  (phase retardation) between a pair of mutually orthogonal polarized optical beam components. The amount of phase retardation is a function of the wavelength, the dispersion characteristics of the material used to form the compensator, and the thickness of the compensator. Compensator 98 is rotated at an angular velocity  $\omega$  about an axis substantially parallel to the propagation direction of beam 106, preferably by an electric motor 100. Compensator 98 can be any conventional wave-plate compensator, for example those made of crystal quartz. The thickness and material of the compensator 98 are selected such that a desired phase retardation of the beam is induced. In the preferred embodiment, compensator 98 is a bi-plate compensator constructed of two parallel plates of anisotropic (usually birefringent) material, such as quartz crystals of opposite handedness, where the fast axes of the two plates are perpendicular to each other and the thicknesses are nearly equal, differing only by enough to realize a net first-order retardation for the wavelength produced by the light source 90.

[0030] Beam 106 then interacts with analyzer 102, which serves to mix the polarization states incident on it. In this embodiment, analyzer 102 is another linear polarizer, preferably oriented at an azimuth angle of 45 degrees relative to the plane of incidence. However, any optical device that serves to appropriately mix the incoming polarization states can be used as an analyzer. The analyzer 102 is preferably a quartz Rochon or Wollaston prism. The rotating compensator 98 changes the polarization state of the beam as it rotates such that the light transmitted by analyzer 102 is characterized by:

$$I(t) = (\frac{1}{2})[|E_x|^2(1 + \cos^2(\delta/2) + |E_y|^2 \sin^2(\delta/2)) - Im(E_x E_y^*) \sin \delta \sin(2\omega t) + Re(E_x E_y^*) \sin^2(\delta/2) \sin(4\omega t) + (\frac{1}{2})(|E_x|^2 - |E_y|^2) \sin^2(\delta/2) \cos(4\omega t)] \quad (1)$$

$$= a_o + b_2 \sin(2\omega t) + a_4 \cos(4\omega t) + b_4 \sin(4\omega t), \quad (2)$$

[0031] where  $E_x$  and  $E_y$  are the projections of the incident electric field vector parallel and perpendicular, respectively, to the transmission axis of the analyzer,  $\delta$  is the phase retardation of the compensator, and  $\omega$  is the angular rotational frequency of the compensator.

[0032] For linearly polarized light reflected at non-normal incidence from the specular sample, we have

$$E_x = r_p \cos P \quad (3a)$$

$$E_y = r_s \sin P \quad (3b)$$

[0033] where  $P$  is the azimuth angle of the incident light with respect to the plane of incidence. The coefficients  $a_o$ ,  $b_2$ ,  $a_4$ , and  $b_4$  can be combined in various ways to determine the complex reflectance ratio:

$$r_p/r_s = \tan \psi e^{i\Delta}. \quad (4)$$

[0034] It should be noted that the compensator 98 can be located either between the sample 4 and the analyzer 102 (as shown in FIG. 1), or between the sample 4 and the polarizer 92, with appropriate and well known minor changes to the equations. It should also be noted that polarizer 90, lenses 94/96, compensator 98 and polarizer 102 are all optimized in their construction for the specific wavelength of light produced by light source 90, which maximizes the accuracy of ellipsometer 2.

[0035] Beam 106 then enters detector 104, which measures the intensity of the beam passing through the compensator/analyzer combination. The processor 48 processes the intensity information measured by the detector 104 to determine the polarization state of the light after interacting with the analyzer, and therefore the ellipsometric parameters of the sample. This information processing includes measuring beam intensity as a function of the azimuth (rotational) angle of the compensator about its axis of rotation. This measurement of intensity as a function of compensator rotational angle is effectively a measurement of the intensity of beam 106 as a function of time, since the compensator angular velocity is usually known and a constant.

[0036] By knowing the composition of reference sample 4, and by knowing the exact wavelength of light generated by light source 90, the optical properties of reference sample 4, such as film thickness  $d$ , refractive index and extinction coefficients, etc., can be determined by ellipsometer 2. If the film is very thin, such as less than or equal to about 20 angstroms, the thickness  $d$  can be found to first order in  $d/\lambda$ , by solving



$$\frac{\rho - \rho_o}{\rho_o} = \frac{4\pi id \cos \theta}{\lambda} \frac{\epsilon_s(\epsilon_s - \epsilon_o)(\epsilon_o - \epsilon_s)}{\epsilon_o(\epsilon_s - \epsilon_o)(\epsilon_s \cos^2 \theta - \epsilon_o)}, \quad (5)$$

[0037] where

$$\rho_o = \tan \Psi_o e^{i\Delta_o} \quad (6)$$

$$= \frac{\sin^2 \theta - \cos \theta (\epsilon_s / \epsilon_o - \sin^2 \theta)^{1/2}}{\sin^2 \theta + \cos \theta (\epsilon_s / \epsilon_o - \sin^2 \theta)^{1/2}} \quad (7)$$

[0038] which is the value of  $\rho = \tan \psi e^{i\Delta}$  for  $d=0$ . Here,  $\lambda$ =wavelength of light; and  $\epsilon_s$ ,  $\epsilon_o$  and  $\epsilon_a$  are the dielectric functions of the substrate, thin oxide film, and ambient, respectively, and  $\theta$  is the angle of incidence.

[0039] If the film thickness  $d$  is not small, then it can be obtained by solving the equations

$$\rho = r_p / r_s, \text{ where} \quad (8)$$

$$r_p = \frac{r_{p,oo} + Z r_{p,so}}{1 + Z r_{p,oo} r_{p,so}} \quad (9)$$

$$r_s = \frac{r_{s,oo} + Z r_{s,so}}{1 + Z r_{s,oo} r_{s,so}} \quad (10)$$

[0040] and where

$$Z = e^{2ikd}, \quad (11)$$

$$Ck_{o\perp}/\omega = n_{o\perp} = (\epsilon_o/\epsilon_a - \sin^2 \theta)^{1/2} \quad (12)$$

$$r_{s,so} = \frac{n_{o\perp} - n_{s\perp}}{n_{o\perp} + n_{s\perp}} \quad (13)$$

$$r_{s,oo} = \frac{n_{o\perp} - n_{o\perp}}{n_{o\perp} + n_{o\perp}} \quad (14)$$

$$r_{p,so} = \frac{\epsilon_s n_{o\perp} - \epsilon_o n_{s\perp}}{\epsilon_s n_{o\perp} + \epsilon_o n_{s\perp}} \quad (15)$$

$$r_{p,oo} = \frac{\epsilon_o n_{o\perp} - \epsilon_a n_{o\perp}}{\epsilon_o n_{o\perp} + \epsilon_a n_{o\perp}} \quad (16)$$

[0041] and in general

$$n_{j\perp} = (\epsilon_j - \epsilon_a \sin^2 \theta)^{1/2}, \quad (17)$$

[0042] where  $j$  is  $s$  or  $a$ . These equations generally have to be solved numerically for  $d$  and  $n_o$  simultaneously, using  $\epsilon_s$ ,  $\epsilon_a$ ,  $\Lambda$ , and  $\theta$ , which are known.

[0043] Once the thickness  $d$  of film **8** has been determined by ellipsometer **2**, then the same sample **4** is probed by the other optical measurement devices BPE **10**, BPR **12**, BRS **14**, DUV **16**, and BSE **18** which measure various optical parameters of the sample **4**. Processor **48** then calibrates the processing variables used to analyze the results from these optical measurement devices so that they produce accurate results. For each of these measurement devices, there are system variables that affect the measured data and need to be accounted for before an accurate measurement of other samples can be made. In the case of BPE **10**, the most significant variable system parameter is the phase shift that occurs due to the optical elements along the BPE optical path. Environmental changes to these optical elements result in an overall drift in the ellipsometric parameter  $A$ , which then translates into a sample thickness drift calculated by the processor **48** from BPE **10**. Using the measured optical parameters of BPE **10** on reference sample **4**, and using Equation 5 and the thickness of film **8** as determined from calibration ellipsometer **2**, the processor **48** calibrates BPE **10** by deriving a phase offset which is applied to measured results from BPE **10** for other samples, thereby establishing an accurate BPE measurement. For BSE **18**, multiple phase offsets are derived for multiple wavelengths in the measured spectrum.

[0044] For the remaining measurement devices, BPR **12**, BRS **14** and DUV **16**, the measured reflectances can also be affected by environmental changes to the optical elements in the beam paths. Therefore, the reflectances  $R_{ref}$  measured by BPR **12**, BRS **14** and DUV **16** for the reference sample **4** are used, in combination with the measurements by ellipsometer **2**, to calibrate these systems. Equations 9-17 are used to calculate the absolute reflectances  $R_{ref}^c$  of reference sample **4** from the measured results of ellipsometer **2**. All measurements by the BPR/BRS/DUV devices of reflectance ( $R_s$ ) for any other sample are then scaled by processor **48** using the normalizing factor in equation 18 below to result in accurate reflectances  $R$  derived from the BPR, BRS and DUV devices:

$$R = R_s (R_{ref}^c / R_{ref}) \quad (18)$$

[0045] In the above described calibration techniques, all system variables affecting phase and intensity are determined and compensated for using the phase offset and reflectance normalizing factor discussed above, thus rendering the optical measurements made by these calibrated optical measurement devices absolute.

[0046] The above described calibration techniques are based largely upon calibration using the derived thickness  $d$  of the thin film. However, calibration using ellipsometer **2** can be based upon any of the optical properties of the reference sample that are measurable or determinable by ellipsometer **2** and/or are otherwise known, whether the sample has a single film thereon, has multiple films thereon, or even has no film thereon (bare sample).

[0047] The advantage of the present invention is that a reference sample having no thin film thereon, or having thin film thereon with an unknown thickness which may even vary slowly over time, can be repeatedly used to accurately calibrate ultra-sensitive optical measurement devices.

[0048] The output of light source **90** can also be used to calibrate the wavelength measurements made by spectrom-

eter 58. The sample 4 can be tipped, or replaced by a tipped mirror, to direct beam 106 up to mirror 42 and to dispersion element 64. By knowing the exact wavelength of light produced by light source 90, processor 48 can calibrate the output of detector 66 by determining which pixel(s) corresponds to that wavelength of light.

[0049] It should be noted that the calibrating ellipsometer 2 of the present invention is not limited to the specific rotating compensator ellipsometer configuration discussed above. The scope of the present invention includes any ellipsometer configuration in conjunction with the light source 90 (having a known wavelength) that measures the polarization state of the beam after interaction with the sample and provides the necessary information about sample 4 for calibrating non-contact optical measurement devices.

[0050] For example, another ellipsometric configuration is to rotate polarizer 92 or analyzer 100 with motor 100, instead of rotating the compensator 98. The above calculations for solving for thickness d still apply.

[0051] In addition, null ellipsometry, which uses the same elements as ellipsometer 2 of FIG. 1, can be used to determine the film thickness d for calibration purposes. The ellipsometric information is derived by aligning the azimuthal angles of these elements until a null or minimum level intensity is measured by the detector 104. In the preferred null ellipsometry embodiment, polarizers 92 and 102 are linear polarizers, and compensator 98 is a quarter-wave plate. Compensator 98 is aligned so that its fast axis is at an azimuthal angle of 45 degrees relative to the plane of incidence of the sample 4. Polarizer 92 has a transmission axis that forms an azimuthal angle P relative to the plane of incidence, and polarizer 102 has a transmission axis that forms an azimuthal angle A relative to the plane of incidence. Polarizers 92 and 102 are rotated about beam 106 such that the light is completely extinguished (minimized) by the analyzer 102. In general, there are two polarizer 92/102 orientations ( $P_1, A_1$ ) and ( $P_2, A_2$ ) that satisfy this condition and extinguish the light. With the compensator inducing a 90 degree phase shift and oriented with an azimuthal angle at 45 degree relative to the plane of incidence, we have:

$$P_2 = P_1 \pm \pi/2 \quad (19)$$

$$A_2 = -A_1 \quad (20)$$

$$\psi = A_1 \geq 0 \quad (21)$$

[0052] (where  $A_1$  is the condition for which A is positive).

$$\Delta = 2P_1 + \pi/2 \quad (22)$$

[0053] which, when combined with equations 5-10, allows the processor to solve for thickness d.

[0054] Null ellipsometry is very accurate because the results depend entirely on the measurement of mechanical angles, and are independent of intensity. Null ellipsometry is further discussed by R. M. A. Azzam and N. M. Bashara, in *Ellipsometry and Polarized Light* (North-Holland, Amsterdam, 1977); and by D. E. Aspnes, in *Optical Properties of Solids: New Developments*, ed. B. O. Seraphin (North-Holland, Amsterdam, 1976), p. 799.

[0055] It is also conceivable to omit compensator 98 from ellipsometer 2, and use motor 100 to rotate polarizer 92 or analyzer 102. Either the polarizer 92 or the analyzer 102 is

rotated so that the detector signal can be used to accurately measure the linear polarization component of the reflected beam. Then, the circularly polarized component is inferred by assuming that the beam is totally polarized, and what is not linearly polarized must be circularly polarized. Such an ellipsometer, commonly called a rotating-polarizer or rotating-analyzer ellipsometer, is termed "an incomplete" polarimeter, because it is insensitive to the handedness of the circularly polarized component and exhibits poor performance when the light being analyzed is either nearly completely linearly polarized or possesses a depolarized component. However, using UV light from source 90, the substrate of materials such as silicon contribute enough to the overall phase shift of the light interacting with the sample that accurate results can be obtained without the use of a compensator. In such a case, the same formulas above can be used to derive thickness d, where the phase shift induced by the compensator is set to be zero.

[0056] It is to be understood that the present invention is not limited to the embodiments described above and illustrated herein, but encompasses any and all variations falling within the scope of the appended claims. For example, beams 24, 26, and/or 106 can be transmitted through the sample, where the beam properties (including the beam polarization state) of the transmitted beam are measured. Further, a second compensator can be added, where the first compensator is located between the sample and the analyzer, and the second compensator located between the sample and the light source 90, as illustrated in FIG. 4. These compensators could be static or rotating. In addition, to provide a static or varying retardation between the polarization states, compensator 98 can be replaced by a non-rotating optoelectronic element or photo-elastic element, such as a piezoelectric cell retarder which are commonly used in the art to induce a sinusoidal or static phase retardation by applying a varying or static voltage to the cell.

What is claimed is:

1. A reference ellipsometer for calibrating non-contact optical measurement devices using a reference sample that has at least a partially known composition, comprising:

a light generator that generates a quasi-monochromatic beam of light having a known wavelength and a known polarization for interacting with the reference sample, the beam directed at a non-normal angle of incidence relative to the reference sample to interact with the reference sample;

an analyzer that creates interference between S and P polarized components in the light beam after the light beam has interacted with reference sample; and

a detector that measures the intensity of the light after the beam has passed through the analyzer; and

a processor that determines the polarization state of the light beam entering the analyzer, from the intensity measured by the detector, wherein the processor determines an optical property of the reference sample based upon the determined polarization state, the known wavelength of light from the light generator and the at least partially known composition of the reference sample;

wherein the processor operates at least one other non-contact optical measurement device that measures an

optical parameter of the reference sample, and the processor calibrates the other optical measurement device by comparing the measured optical parameter from the other non-contact optical measurement device to the determined optical property from the reference ellipsometer.

2. The reference ellipsometer of claim 1, further comprising:

a retarder disposed in the path of the light beam to induce a phase retardation of one polarization component in the light beam with respect to the phase of an orthogonal polarization component in the light beam;

3. The reference ellipsometer of claim 2, wherein the retarder is rotatable about an axis substantially parallel to the propagation direction of the light beam, and wherein the detector measures the intensity of light after interaction with the analyzer as a function of a rotation angle of the retarder about the axis.

4. The reference ellipsometer of claim 1, wherein the light generator includes a light source and a polarizer.

5. The reference ellipsometer of claim 4, wherein at least one of the polarizer and the analyzer is rotatable about an axis substantially parallel to the propagation direction of the light beam, and wherein the detector measures the intensity of light after interaction with the analyzer as a function of a rotation angle of the one of the polarizer and the analyzer.

6. The reference ellipsometer of claim 2, wherein the light generator includes a light source and a polarizer, the polarizer and the retarder and the analyzer are each aligned with an azimuthal angle about the light beam to minimize the intensity of light reaching the detector, and wherein the processor determines the optical property of the reference sample based upon the known wavelength of light from the light generator, the at least partially known composition of the reference sample, and the azimuthal angles of the polarizer, retarder and analyzer.

7. The reference ellipsometer of claim 1, further comprising:

a first retarder disposed in the path of the light beam between the light generator and the reference sample to induce a first phase retardation of one polarization state in the light beam with respect to the phase of an orthogonal polarization state in the light beam; and

a second retarder disposed in the path of the light beam between the reference sample and the analyzer to induce a second phase retardation of one polarization state in the light beam with respect to the phase of an orthogonal polarization state in the light beam.

8. The reference ellipsometer of claim 2, wherein the retarder is one of an opto-electronic element and a photo-elastic element, such that the retardation of the one polarization state is induced by an external electric signal applied to the one of the opto-electronic and photo-elastic elements.

9. The reference ellipsometer of claim 1, wherein the light generator includes a wavelength stable light source that produces light having a stable known wavelength to within 1 percent.

10. The reference ellipsometer of claim 1, wherein the light generator includes a light source and a monochromator that measures the wavelength of the beam produced by the light source.

11. An optical measurement system for evaluating a reference sample that has at least a partially known composition, comprising:

at least one non-contact optical measurement device that includes:

a first light generator that generates a first beam of light that is directed to interact with the reference sample,

a first detector that measures the intensity of the first beam of light after the interaction with the reference sample, and

a processor that determines an optical parameter of the reference sample from the intensity measured by the first detector; and

a reference ellipsometer that includes:

a second light generator that generates a second beam of quasi-monochromatic light having a known wavelength and a known polarization for interacting with the reference sample, the second beam directed at a non-normal angle of incidence relative to the reference sample to interact with the reference sample;

an analyzer that creates interference between S and P polarized components in the second light beam after the second light beam has interacted with reference sample; and

a second detector that measures the intensity of the second light after the second beam has passed through the analyzer; and

wherein the processor determines the polarization state of the second light beam entering the analyzer from the intensity measured by the second detector, and determines an optical property of the reference sample based upon the determined polarization state, the known wavelength of light from the second light generator and the at least partially known composition of the reference sample; and

wherein the processor calibrates the optical measurement device by comparing the optical parameter of the reference sample determined from the first detector to the optical property of the reference sample determined from the second detector.

12. The optical measurement system of claim 11, further comprising:

a retarder disposed in the path of the second light beam to induce a phase retardation of one polarization component in the second light beam with respect to the phase of an orthogonal polarization component in the second light beam;

13. The optical measurement system of claim 12, wherein the retarder is rotatable about an axis substantially parallel to the propagation direction of the second light beam, and wherein the second detector measures the intensity of second light beam after interaction with the analyzer as a function of a rotation angle of the retarder about the axis.

14. The optical measurement system of claim 11, wherein the second light generator includes a light source and a polarizer.

15. The optical measurement system of claim 14, wherein at least one of the polarizer and the analyzer is rotatable about an axis substantially parallel to the propagation direc-

tion of the second light beam, and wherein the second detector measures the intensity of the second light beam after interaction with the analyzer as a function of a rotation angle of the one of the polarizer and the analyzer.

**16.** The optical measurement system of claim 12, wherein the second light generator includes a light source and a polarizer, the polarizer and the retarder and the analyzer are each aligned with an azimuthal angle about the second light beam to minimize the intensity of light reaching the second detector, and wherein the processor determines the optical property of the reference sample based upon the known wavelength of light from the second light generator, the at least partially known composition of the reference sample, and the azimuthal angles of the polarizer, retarder and analyzer.

**17.** The optical measurement system of claim 11, further comprising:

- a first retarder disposed in the path of the second light beam between the second light generator and the reference sample to induce a first phase retardation of one polarization state in the second light beam with respect to the phase of an orthogonal polarization state in the second light beam; and

- a second retarder disposed in the path of the second light beam between the reference sample and the analyzer to induce a second phase retardation of one polarization state in the second light beam with respect to the phase of an orthogonal polarization state in the second light beam.

**18.** The optical measurement system of claim 12, wherein the retarder is one of an opto-electronic element and a photo-elastic element, such that the retardation of the one polarization state is induced by an external electric signal applied to the one of the opto-electronic and photo-elastic elements.

**19.** The optical measurement system of claim 11, wherein the second light generator includes a wavelength stable light source that produces light having a stable known wavelength to within 1 percent.

**20.** The optical measurement system of claim 11, wherein the second light generator includes a light source and a monochromator that measures the wavelength of the second light beam produced by the light source.

**21.** The optical measurement system of claim 11, wherein:

- the one non-contact optical measurement device is a beam profile ellipsometer that includes a quarter wave plate and a polarizer,

- the first detector is a quad-cell detector having four radially disposed quadrants that each intercept about one quarter of the first beam of light after interaction with the reference sample and produce an output signal based upon the intensity of light incident thereon, and

- the processor uses the difference between the sums of the output signals of diametrically opposed quadrants to determine the optical parameter of the reference sample.

**22.** The optical measurement system of claim 11, wherein the one non-contact optical measurement device is a beam profile ellipsometer that includes:

- a lens for focusing the first beam substantially normal onto the surface of the reference sample such that

- various rays within the focused first beam create a spread of angles of incidence with respect to the sample surface,

- a retarder disposed in the path of the first light beam to induce a phase retardation of one polarization state in the first light beam with respect to the phase of an orthogonal polarization state in the first light beam;

- a second analyzer that creates interference between S and P polarized components in the first light beam after the first light beam has interacted with reference sample,

- wherein the first detector measures the intensity of the first light beam after the interaction with the retarder and second analyzer along two orthogonal axes, the first detector generating an output that integrates the intensity of various rays having different angles of incidence, the output having two components corresponding to the two orthogonal axes, and wherein the processor determines the optical parameter of the reference sample based on the output of the first detector.

**23.** The optical measurement system of claim 11, wherein the one non-contact optical measurement device is a beam profile reflectometer that includes a lens for focusing the first beam substantially normal onto the surface of the reference sample such that various rays within the focused first beam create a spread of angles of incidence with respect to the sample surface, the first detector receives the first beam after it has been reflected from the surface of the reference sample and measures the intensity of various rays as a function of position within the reflected first beam, with the position of the rays within the reflected first beam corresponding to specific angles of incidence with respect to the sample surface, and wherein the processor determines the optical parameter of the reference sample based upon the angular dependent intensity measurements made by the first detector.

**24.** The optical measurement system of claim 11, wherein the one non-contact optical measurement device is a broadband spectroscopic measurement device that includes:

- a lens for focusing the first beam substantially normal onto the surface of the reference sample such that various rays within the focused first beam create a spread of angles of incidence with respect to the sample surface, and

- a dispersive element that angularly disperses the first beam as a function of wavelength to individual detector elements contained in the first detector;

- wherein the first light generator is a polychromatic light source that generates the first beam having multiple wavelengths of light therein, the first detector receives the first beam after it has interacted with the sample and measures the intensity of the first beam as function of wavelength, and wherein the processor determines the optical parameter of the reference sample based upon the wavelength dependent intensity measurements made by the first detector.

**25.** The optical measurement system of claim 24, wherein the dispersive element angularly disperses the first beam transmitted by the second analyzer as a function of wavelength in one axis, and as a function of radial position within the first beam in an orthogonal axis to the one axis, and

wherein the first detector measures intensities of light in the first beam both as a function of wavelength and as a function of angle of incidence.

26. The optical measurement system of claim 11, wherein the one non-contact optical measurement device is a broad-band spectroscopic ellipsometer that includes:

the first light generator generating the first beam having a range of wavelengths therein and having a known polarization for interacting with the reference sample,

a retarder disposed in the path of the first light beam to induce a range of phase retardations of a polarization state of the light beam based upon the range of wavelengths generated by the first light generator and the retarder material and thickness,

the retarder being rotatable about an axis substantially parallel to the propagation direction of the first light beam;

a second analyzer that interacts with the first light beam after the first light beam interacts with the reference sample; and

the first detector measures the intensity of the first light beam after the interaction with the second analyzer as a function of wavelength and of a rotation angle of the compensator about the axis, wherein the intensities correspond to the polarization state of the first light beam entering the second analyzer, and wherein the processor determines the optical parameter of the reference sample based upon the intensity measurements made by the first detector.

27. A method for calibrating an optical measurement device using a reference sample having at least a partially known composition, comprising the steps of:

optically probing the reference sample with an off-axis ellipsometer that includes:

a light generator that generates a quasi-monochromatic beam of light having a known wavelength and a known polarization for interacting with the reference sample, the beam directed at a non-normal angle of incidence relative to the reference sample to interact with the reference sample,

an analyzer that creates interference between S and P polarized components in the light beam after the light beam has interacted with reference sample, and

a detector that measures the intensity of the light after the beam has passed through the analyzer;

determining an optical property of the reference sample based upon the intensity measured by the detector, the known wavelength of light from the light generator and the at least partially known composition of the reference sample;

measuring an optical parameter of the reference sample using the optical measurement device; and

calibrating the optical measurement device by comparing the optical parameter measured by the optical measurement device to the determined optical property of the reference sample.

\* \* \* \* \*