

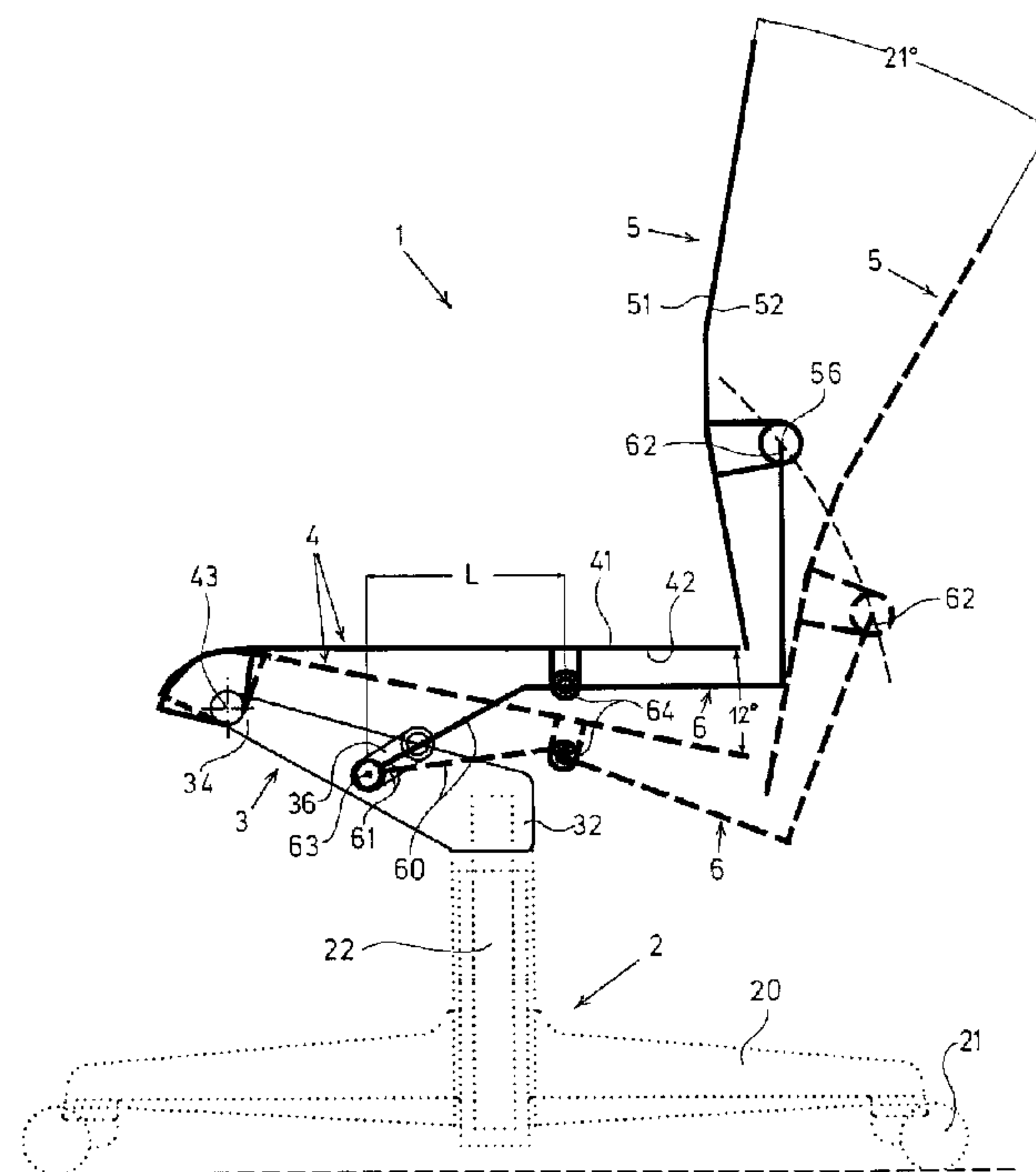

(22) Date de dépôt/Filing Date: 1998/06/10  
(41) Mise à la disp. pub./Open to Public Insp.: 1998/12/20  
(45) Date de délivrance/Issue Date: 2007/05/01  
(30) Priorité/Priority: 1997/06/20 (DE197 26 160.4)

(51) Cl.Int./Int.Cl. *A47C 1/032* (2006.01),  
*A47C 3/18* (2006.01)  
(72) Inventeur/Inventor:  
UHLENBROCK, JOHANNES, DE  
(73) Propriétaire/Owner:  
UHLENBROCK, JOHANNES, DE  
(74) Agent: GOWLING LAFLEUR HENDERSON LLP

(54) Titre : FAUTEUIL, EN PARTICULIER FAUTEUIL DE BUREAU PIVOTANT  
(54) Title: SEAT, IN PARTICULAR OFFICE SWIVEL CHAIR



(57) **Abrégé/Abstract:**

The invention relates to a seat (1), in particular an office swivel chair comprising a foot (2) with a centre column (22) extending upwards therefrom wherein the centre column (22) may be variable in length and/or spring mounted, a seat carrier (3) secured at the upper end of the centre column (22), a seat top (4) pivotable around a horizontal axis (43) close to the front edge of the seat top, connected with the seat carrier (3), and biased by a spring arrangement with an upwards directed force, and a back rest (5) attached at at least one upwards extending lever (6) which is articulately connected with the seat carrier (3) at a first link point (63) under the seat top (4), and spaced therefrom is articulately connected with the underside (42) of the seat top (4) at a second link point (64) wherein both link points (63, 64) comprise swivelling axes in parallel with the seat top swivelling axis (43). The seat according to the invention is characterized in that the length (L) of the lever (6) between the first link point (63) and the second link point (64) is variable by displacing the first link point (63) and/or the second link point (64) in the direction of the lever (6).

Abstract:

The invention relates to a seat (1), in particular an office swivel chair comprising a foot (2) with a centre column (22) extending upwards therefrom wherein the centre column (22) may be variable in length and/or spring mounted, a seat carrier (3) secured at the upper end of the centre column (22), a seat top (4) pivotable around a horizontal axis (43) close to the front edge of the seat top, connected with the seat carrier (3), and biased by a spring arrangement with an upwards directed force, and a back rest (5) attached at at least one upwards extending lever (6) which is articulatedly connected with the seat carrier (3) at a first link point (63) under the seat top (4), and spaced therefrom is articulatedly connected with the underside (42) of the seat top (4) at a second link point (64) wherein both link points (63, 64) comprise swivelling axes in parallel with the seat top swivelling axis (43).

The seat according to the invention is characterized in that the length (L) of the lever (6) between the first link point (63) and the second link point (64) is variable by displacing the first link point (63) and/or the second link point (64) in the direction of the lever (6).

(Figure for abstract: Figure 2b)

Specification:Seat, in particular office swivel chair

The present invention relates to a seat, in particular an office swivel chair comprising a foot with a centre column extending upwards therefrom wherein the centre column may be variable in length and/or spring mounted, a seat carrier secured at the upper end of the centre column, a seat top pivotable around a horizontal axis close to the front edge of the seat top, connected with the seat carrier, and biased by a spring arrangement with an upwards directed force, and a back rest attached at at least one upwards extending lever which is articulately connected with the seat carrier at a first link point under the seat top, and spaced therefrom is articulately connected with the underside of the seat top at a second link point wherein both link points comprise swivelling axes in parallel with the seat top swivelling axis.

A seat of the type mentioned is known from US-PS 4 709 962. With such a seat the lever carries the back rest and is linked at the seat carrier, and the seat top, and serves for generating a coupled movement of seat top and back rest. More specifically the coupling is comprised therein that the back rest also pivots when the seat top is pivoted, however, in a different angle as the seat top. The ratio of the pivot angles to each other is set at a predetermined value in the range between approxi-

mately 1 : 1,3 and 1 : 2,5 with the seats known in the current market. With this construction of the seat in particular it shall be attained that the user of the seat may take his/her position between an upright position with a raised seat top, and a straight backwards directed back rest, and a reclined position with a seat top lowered in the rear area, and a back rest in an angled position, thereby avoiding the situation that when changing the seat position the back rest will shift at the back of the user upwards or downwards in an unpleasant way.

A further relevant seat is known from DE 43 12 113 C1. This document describes a seat with the seat adjustable in the inclination thereof and pivotable around a horizontal swivelling axis in the front area, and a back rest with an overproportional inclination in relation to the inclination change of the seat. Therein the seat is articulatedly connected with swivelling levers with the one ends thereof carrying the back rest, and with the other ends thereof rotatably supported at the bearing support of the chair structure. The swivelling levers are spaced from the rear end of the seat and linked thereto, and the sections of the swivelling levers rotatably supported at the bearing support, and take an obtuse angle towards the support area in relation to the sections of the swivelling levers adjacent to the link axis of the seat. Furthermore a return spring is provided to automatically set back the seat top and the back rest from the idle position into the working position when the load is released. In order to adapt the seat to a wide range of user weights it is provided with this seat that the swivelling axis of the swivelling levers is displaceable in relation to the bearing support, and that the return spring is arranged between the bearing support and the sections of the swivelling levers rotatably supported at the bearing support, and that it is

adjustable in the mounting position in relation to the swivelling bearings variable such that the torque exerted by the spring force around the swivelling axis is variable. It is not provided that the ratio between the swivelling angle of the seat and the swivelling angle of the back may be varied with the seat.

From the DE 44 39 290 A1 a synchronous adjusting device for office chairs, seats and the like is known comprising a seat member, a back member with a back rest attached to a back carrier or integrated therein, and a stationary carrier construction to which the seat member is linked wherein the back carrier is connected with the seat member and the carrier construction, and the seat member carries out a swivelling movement when the back inclination is enlarged. In order to keep the number of the link points, and the number of the additional connecting points low, and to lower the construction effort of such a synchronous adjustment device, it is provided that the back carrier is directly pivotally connected with the seat member and with the carrier construction. In an embodiment of this adjustment device with at least one of the swivelling connections a shifting gate for the turning axis is provided for overlapping a displacing movement with a rotational movement around the swivelling axis. Thereby influence may be taken on the course of the synchronous movements of the seat member and the back member with a corresponding shape of the shifting gate. It is a disadvantage of this synchronous adjustment device that the course of the synchronous movements of the seat member and the back member is set by the shape of the shifting gate, and may no longer be influenced by the user of the seat. Furthermore with this example of the seat a synchronous adjustment is provided in such a way that when pivoting the back rest backwards the seat top is raised in its lower area, and that vice versa when pivoting the back rest to the front

the seat top is lowered in the rear area. This kind of synchronous adjustment is considered no longer to be ergonomically advantageous.

It is a disadvantage of all these known seats known from prior art that because of the preset ratios between the swivelling angles of seat top and back rest there is always a compromise between the different requirements of various users which occur because of different anatomical conditions. The ratio of the swivelling angles of seat top and back rest is always preset when manufacturing the seat, and afterwards may not be changed by the user.

It is therefore the object to provide a seat of the type mentioned before which avoids all the quoted disadvantages, and which in particular enables a change at will of the ratio of the tilting angles of seat top and back rest by the user of the seat in order to better adapt the seat to the different requirements of comfort and anatomical conditions of different users.

According to the invention this object is attained with a seat of the type mentioned before which is characterized in that the length of the lever between the first link point and the second link point is variable by displacing the first link point and/or the second link point in the direction of the lever.

As the length of the lever between the first and the second link point defines the ratio of the tilting angles of seat top and back rest in this way an advantageous possibility is provided to influence the ratio of the tilting angles. For displacing the first and/or second link point advantageously such technical means are used, that the displacement may be accomplished by the user of the seat. In this way each user of the seat

-5-

may select and set a pleasant and appropriate ratio of the tilting angle of seat top and back rest. As a rule it is sufficient to either displace the first or the second link point in case a particularly large range of variation of the ratio of the tilting angles is required it may be practical to displace both link points.

Independent from the fact whether the first link point or the second link point is displaceable, or whether both link points are displaceable the back rest may either be attached rigidly at the upper free end of the lever or may be linked at the upper free end of the lever swivelling around an axis which is in parallel with the seat top swivelling axis.

In the following embodiments of the seat according to the invention are further explained referring to a drawing. The figures of the drawing illustrate:

Figure 1a a seat in a first embodiment with a first tilting angle ratio between seat top and back rest, in two different tilting positions, in a schematic lateral view,

Figure 1b the seat of Figure 1a with a changed tilting angle ratio in the same type of illustration as in Figure 1a,

Figure 2a the seat in a second embodiment with a first tilting angle ratio between seat top and back rest also in a schematic lateral view,

Figure 2b the seat of Figure 2a now in a second swivelling angle ratio, and

Figure 2c the seat of Figure 2a now in a third swivelling angle ratio.

According to Figure 1a the illustrated embodiment of a seat 1, in this case an office swivelling chair, comprises a foot 2, a seat carrier 3 connected with the foot 2, a seat top 4 pivotably linked to the seat carrier 3, and a back rest 5.

The foot 2 comprises several, generally five arms 20 which carry at the outer end thereof a roller 21. The foot 2 further comprises a centre column 22 extending centrally upwards, and being variable in length and/or spring mounted. The foot 2 in total is of known construction and for this reason is illustrated in dashed lines in the drawing.

The seat carrier 3 with the one end 32 thereof is secured to the upper end of the centre column 22 wherein lifting the seat carrier 3 upwards from the centre column 22 is excluded, however, a rotation of the seat carrier 3 around the centre column 22 is still possible.

The seat carrier 3 extends upwards in an angle wherein the outer end 34 thereof is connected to the seat top 4 by means of a swivelling axis 43 which extends in horizontal direction in parallel with the front edge of the seat top 4. Preferably the swivelling axis 43 is designed as a corresponding joint, as an alternative the swivelling axis 43 may be materialized by the use

of a flexible material which enables a corresponding swivelling movement of the seat top 4 in relation to the seat carrier 3. A spring element is provided between the seat carrier 3 and the seat top 4 which is not illustrated in the drawing and known as such. The spring element biases the seat top 4 with an upwards directed force. When using a flexible material a spring force may be exerted by the material itself which must be sufficiently flexible.

The back rest 5 extends upwards from the rear end of the seat top 4 which is at the right side of the drawing wherein no direct connection exists between the seat top 4 and the back rest 5. The back rest 5 is connected with the remaining part of the seat 1 by means of a lever 6. The lever 6 is connected with the seat carrier and with the seat top 4 in two link points 63 and 64. Therein the link point 63 is designed as a link element which is displaceable and lockable in a guide 36 in the seat carrier 3. On the other hand the link point 64 is stationarily secured at the underside 42 of the seat top 4 wherein a displacement of the lever 6 in the longitudinal direction thereof is possible through the link point 64. The front end 61 of the lever 6 which is the left end in the drawing is secured against a movement in longitudinal direction thereof in the link point 63. At the right side of the second link point 64 the lever 6 firstly extends backwards below the seat top 4, which is to the right side in the drawing, and thereupon is angled upwards. The lever 6 at the upper end 62 thereof is connected to the back rest 5 wherein in the illustrated embodiment the back rest 5 is connected with the lever end 62 pivotally around an axis 56.

The upper side 41 of the seat top 4 and the front side 51 of the back rest 5 are upholstered in the usual way and provided with a cover e.g. of cloth or leather.

In Figure 1a a position of the seat 1 with a raised seat top 4 is illustrated in straight lines in which position the user of the seat 1 takes an upright position. By moving his weight the user of the seat 1 may change his position at the seat 1, and move the seat top 4 against the force of the spring element mentioned into a position extending in an angle backwards and downwards which position is illustrated in dashed lines. The available tilting range of the seat top 4 in each case is  $12^\circ$  in the illustrated embodiment according to Figure 1a and also in the further Figures of the drawing.

By connecting the back rest 5 through the lever 6 with the seat top 4 and the seat carrier 3 on the one hand a transfer of the force of the spring element mentioned also to the back rest 5 is attained, and on the other hand a coupled movement of the seat top 4 and back rest 5 is attained which in the illustrated embodiment according to Figure 1a is such that the back rest 5 covers a tilting angle of  $21^\circ$  when swivelling the seat top 4 by  $12^\circ$ . The length L of the lever section 60 between the two link points 63 and 64 governs the ratio between the tilting angles of seat top 4 and back rest 5. In the condition according to Figure 1a the link point 63 is secured at the left end of the guide 36 in the seat carrier 3. For changing the swivelling angle ratio between the seat top 4 and the back rest 5 the link point 63 may be displaced in its guide 36 wherein Figure 1b now illustrates the condition of the seat 1 wherein the link point 63 has been displaced to the right upper end of the guide 36 and locked there. By this displacement of the link point 63 the length L is changed to a smaller dimension. This decrease of the length L has the consequence that with the same swivelling of the seat top 4 which is again by  $12^\circ$  the back rest 5 now travels through a larger tilting angle which in the example illustrated is  $28^\circ$ .

With the seat 1 according to Figure 1a and Figure 1b the swivelling angle ratio between the swivelling angles of seat top 4 and back rest 5 may be changed between approximately 1 : 1, 75 and 1 : 2, 3 by displacing the link point 63 from the one end of its guide 36 to the other end. Therein the link point 63 for practical reason is designed with such technical means that the user of the seat 1 himself may accomplish the displacement within the guide 36 as well as the locking in the required position. Now the user of the seat 1 may adapt it in an optimal fashion to his comfort requirements and anatomical conditions.

The Figures 2a to 2c illustrate an embodiment of the seat 1 wherein other than in the previous embodiments according to Figure 1a and Figure 1b the second link point 64 may be varied in the position thereof whereas the first link point 63 is stationary at the seat carrier 3.

According to Figure 2a this embodiment comprises the seat 1 which again is an office swivel chair, a known foot 2 to the upper end of which the seat carrier 3 is attached with its lower end 32. Also in this case the seat top 4 is articulatedly connected around the swivelling axis 43 or with the same effect connected with the seat carrier 3 and the free end thereof in a flexible fashion. The back rest 5 again extends upwards behind the seat top 4.

The back rest 5 is connected with the remaining part of the seat 1 by a lever 6 with the lever 6 extending below the seat top 4 at the underside 42 thereof and being angled upwards behind the seat top 4 and carrying the back rest 5 at its free end 62. Also in this case a swivelling connection is provided with an axis 56.

In order to have the second link point 64 adjustable a guide 46 is provided at this seat 1 at the underside 42 of the seat top 4, and along the guide 46 the second link point 64 may be displaced and locked in the desired position with the second link point 64 formed as a link element. The lever 6 extends through the second link point 64 wherein a relative movement between the lever 6 and the link point 64 remains possible in longitudinal direction of the lever.

The front end 61 of the lever 6 is movably supported in the first link point 63 around a horizontal axis which is in parallel with the swivelling axis 43, however, the front end is secured against movement in other directions.

Also with this seat 1 there is a coupled movement of seat top 4 and the back rest 5 by the connection of the back rest 5 through the lever 6 with the seat top 4 and the seat carrier 3 when the seat top 4 is lowered by the load of a user. Again the length L of the lever part 60 between the two link points 63 and 64 governs the swivelling angle ratio between the seat top 4 and the back rest 5. In the condition illustrated in Figure 2a the second link point 64 or the link element forming the link point, respectively, is displaced approximately to the stop at the back side in its guide 46 whereby the length L approximately takes its maximal possible value. With this position of the second link point 64 a swivelling angle of  $16^\circ$  results for the back rest 5 with a swivelling angle of the seat top 4 of  $12^\circ$ . Therein the swivelled position of the seat top 4 and the back rest 5 is illustrated in dashed lines in Figure 2a and also in the following Figures.

In Figure 2b the seat 1 of Figure 2a is illustrated in an approximately middle position of the second link

point 64 within its guide 46 whereby the length L takes a middle value of the possible values for the length L. With this adjustment of the second link point 64 in the embodiment illustrated there results a coupled swivelling of the back rest 5 by  $18^\circ$  when the seat top 4 is swivelled by  $12^\circ$ .

Finally Figure 2c illustrates the seat 1 of Figure 2a and 2b now in a third position of the second link point 64 wherein the link point is displaced to the front as far as possible within its guide 46. The length L approximately reaches its minimal possible value which leads to the fact that when tilting the seat top 4 by  $12^\circ$  the back rest 5 will swivel by  $22^\circ$ .

As it is further illustrated in the Figures 2a to 2c when swivelling the back rest 5 simultaneously a certain downwards movement occurs in relation to the seat top 4 which gives the user of the seat 1 a pleasant feeling as shifting movements of the back rest 5 in relation to the back of the user are avoided.

Also in the seat 1 according to Figure 2a to 2c the link element forming the second link point 64 together with its guide 46 is designed such that a user of the seat 1 may accomplish the displacement and locking of the link point 64 within its guide 46 by himself. Preferably the embodiment is such that no tool is required for the adjustment but only a hand wheel or a lever must be actuated as it is known e.g. from manual height adjustment or back adjustment of seats, in particular office swivel chairs.

As the guide 46 at the underside 42 of the seat top 4 may be designed in great length without any problems a correspondingly large range of variation will result for the length L and at the same time a correspondingly

large range of variation for the swivelling angle ratio between the seat top 4 and the back rest 5. In the example according to Figure 2a to 2c the swivelling angle ratio may be varied between 1 : 1,3 to 1 : 1,8 by displacing the link point 64. An even larger range of variation is possible when the range of variation of the length L is additionally enlarged, either by enlarging the guides 36 and/or 46 or by use of two displaceable link points 63 and 64.

For limiting the manufacturing effort preferably a single lever 6 is used which for practical reasons extends approximately centrally below the seat top 4 and behind the back rest 5. As an alternative also a pair of levers may be used symmetrically left and right of the seat 1 wherein the two levers 6 may extend over a part of the length thereof besides the seat top 4 or directly at the edge areas thereof which may increase the accessibility for displacing the link points 63 and 64. Furthermore the different embodiment and arrangement of the lever 6 or the levers 6 may offer manifold design possibilities for the outer appearance of the seat 1.

**CLAIMS**

1. A seat particularly adapted for use with an office swivel chair comprising a foot with a centre column  
5 extending upwards therefrom wherein the centre column may be variable in length or spring mounted, a seat carrier secured at the upper end of the centre column, a seat top pivotable around a horizontal axis close to a front edge of the seat top, connected with the seat carrier, and  
10 biased by a spring arrangement with an upwards directed force, and a back rest attached at at least one upwards extending lever which is articulately connected with the seat carrier at a first link point under the seat top, and spaced therefrom is articulately connected with the  
15 underside of the seat top at a second link point wherein both link points comprise swivelling axes in parallel with the seat top swivelling axis, wherein the length of the at least one lever between the first link point and the second link point is variable by displacing the first  
20 link point and/or the second link point in the direction of the lever.

2. The seat according to claim 1, characterized in that the first link point is designed as a first link element  
25 to be displaced, either continuously or in several steps, placed and locked in a guide in the seat carrier.

3. The seat according to claim 2, wherein the second link point is designed as a swivelling bearing secured at  
30 the underside of the seat top.

4. The seat according to claim 2 or 3, wherein the at least one lever is guided in the first link point in relation thereof and displaceable in the longitudinal  
35 direction.

5. The seat according to claim 4, wherein the at least one lever is reasonably to be locked against displacement in its longitudinal direction in the first link point, and that the at least one lever is guided displaceably in its longitudinal direction in the second link point.

6. The seat according to claim 1, wherein the second link point is designed as a second link element to be displaced either continuously or in several steps, and locked in a guide at the underside of the seat top.

7. The seat according to claim 6, wherein the first link point is designed as a swivelling bearing secured at the seat carrier.

8. The seat according to claim 6 or 7, wherein the at least one lever is displaceably guided in the second link point in relation to this link point and displaceable in the longitudinal direction, and that the lever end is axially non-displaceably secured in the first link point.

9. The seat according to any one of claims 1 to 8, wherein the back rest is rigidly secured at the upper free end of the at least one lever.

10. The seat according to any one of claims 1 to 8, wherein the back rest is linked at the upper free end of the at least one lever pivotally around an axis in parallel with the seat top swivelling axis.

Fig. 1a

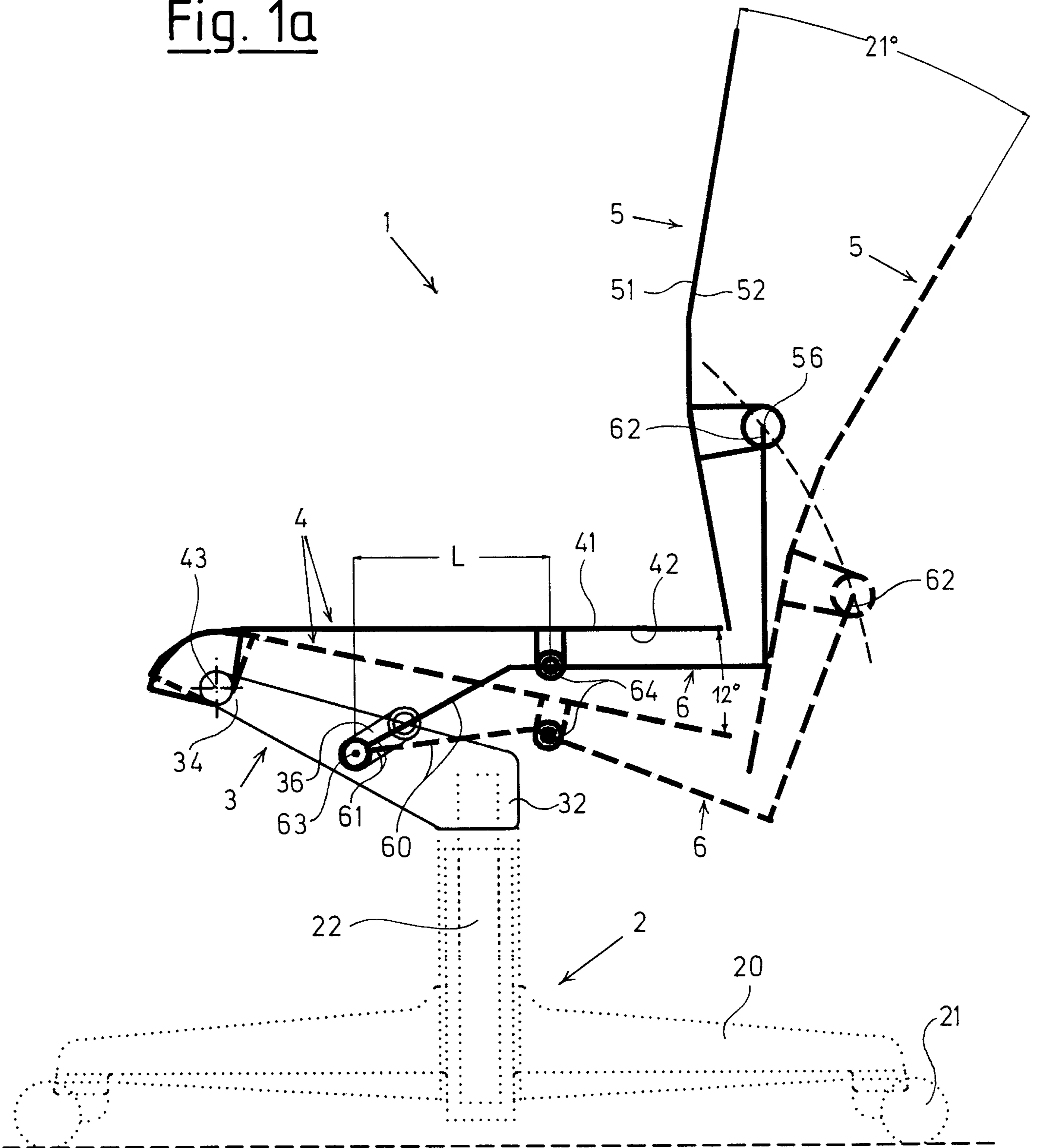

Fig. 1b

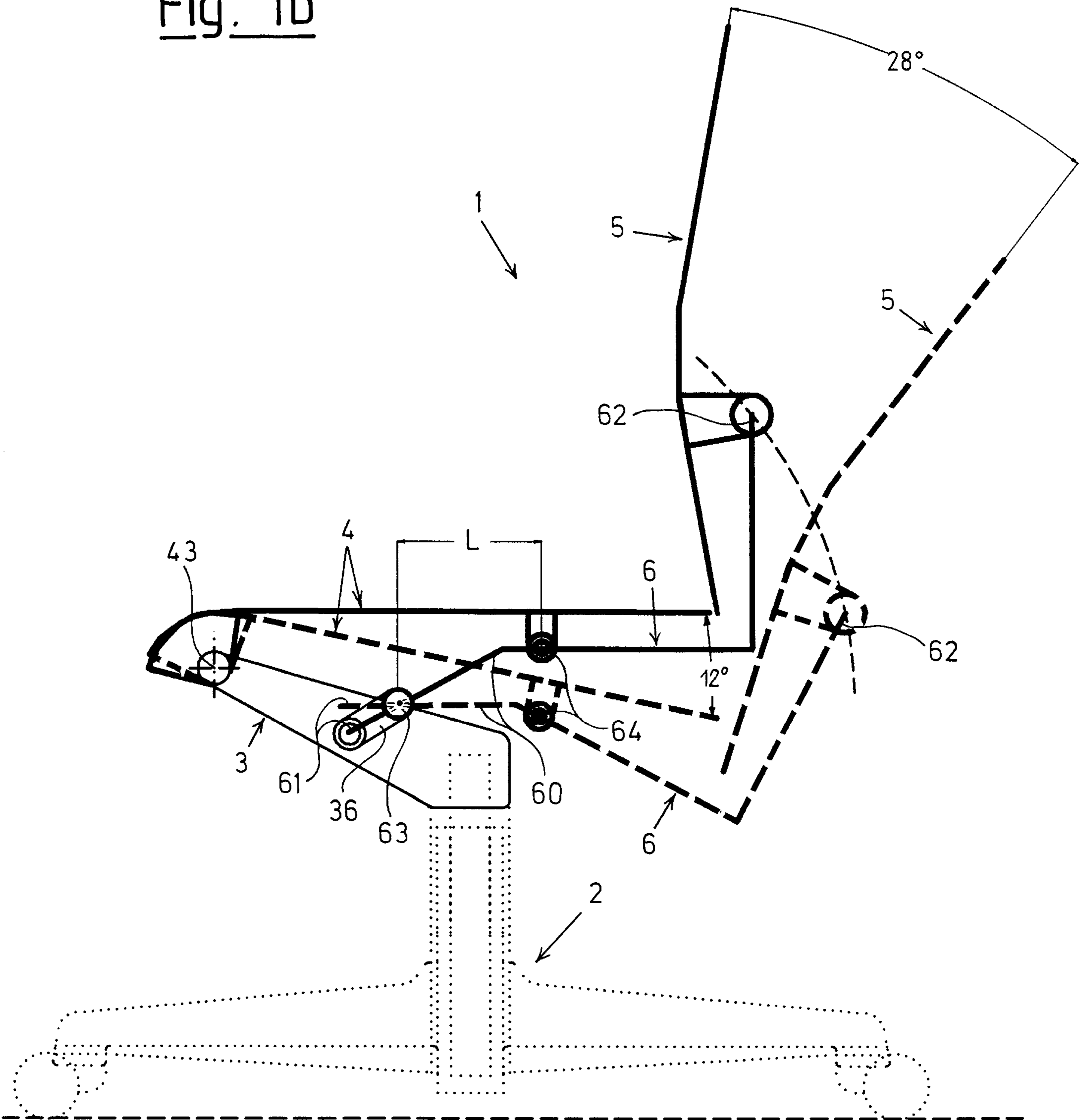



Fig. 2b

