

(19) World Intellectual Property Organization  
International Bureau



(43) International Publication Date  
26 October 2006 (26.10.2006)

PCT

(10) International Publication Number  
**WO 2006/111850 A1**

- (51) International Patent Classification:  
*B65B 11/34* (2006.01)    *B65B 25/00* (2006.01)  
*B65B 61/18* (2006.01)    *B29C 65/74* (2006.01)
- (21) International Application Number:  
PCT/IB2006/001043
- (22) International Filing Date: 19 April 2006 (19.04.2006)
- (25) Filing Language: English
- (26) Publication Language: English
- (30) Priority Data:  
BO2005A000272    21 April 2005 (21.04.2005)    IT
- (71) Applicant (for all designated States except US): **SACMI PACKAGING S.P.A.** [IT/IT]; Via Brodolini 10/A, 40026 Imola (IT).
- (72) Inventors; and
- (75) Inventors/Applicants (for US only): **FRABETTI, Fabio** [IT/IT]; Via M. D'Azeglio, 48, I-40123 Bologna (IT). **BARALDI, Luca** [IT/IT]; Via C. Carolio, 5, 40133 BOLOGNA (IT). **GIOVANNINI, Flavio** [IT/IT]; Via Valle Verde, 26, 40067 Rastignano (IT).
- (74) Agent: **AGAZZANI, Giampaolo**; Agazzani & Associati S.R.L., Via dell'Angelo Custode 11/6, I-40141 Bologna (IT).
- (81) Designated States (unless otherwise indicated, for every kind of national protection available): AE, AG, AL, AM, AT, AU, AZ, BA, BB, BG, BR, BW, BY, BZ, CA, CH, CN, CO, CR, CU, CZ, DE, DK, DM, DZ, EC, EE, EG, ES, FI, GB, GD, GE, GH, GM, HR, HU, ID, IL, IN, IS, JP, KE, KG, KM, KN, KP, KR, KZ, LC, LK, LR, LS, LT, LU, LV, LY, MA, MD, MG, MK, MN, MW, MX, MZ, NA, NG, NI, NO, NZ, OM, PG, PH, PL, PT, RO, RU, SC, SD, SE, SG, SK, SL, SM, SY, TJ, TM, TN, TR, TT, TZ, UA, UG, US, UZ, VC, VN, YU, ZA, ZM, ZW.
- (84) Designated States (unless otherwise indicated, for every kind of regional protection available): ARIPO (BW, GH, GM, KE, LS, MW, MZ, NA, SD, SL, SZ, TZ, UG, ZM, ZW), Eurasian (AM, AZ, BY, KG, KZ, MD, RU, TJ, TM), European (AT, BE, BG, CH, CY, CZ, DE, DK, EE, ES, FI, FR, GB, GR, HU, IE, IS, IT, LT, LU, LV, MC, NL, PL, PT,

[Continued on next page]

(54) Title: WRAPPING DEVICE FOR ARTICLES AND WRAPPING METHOD

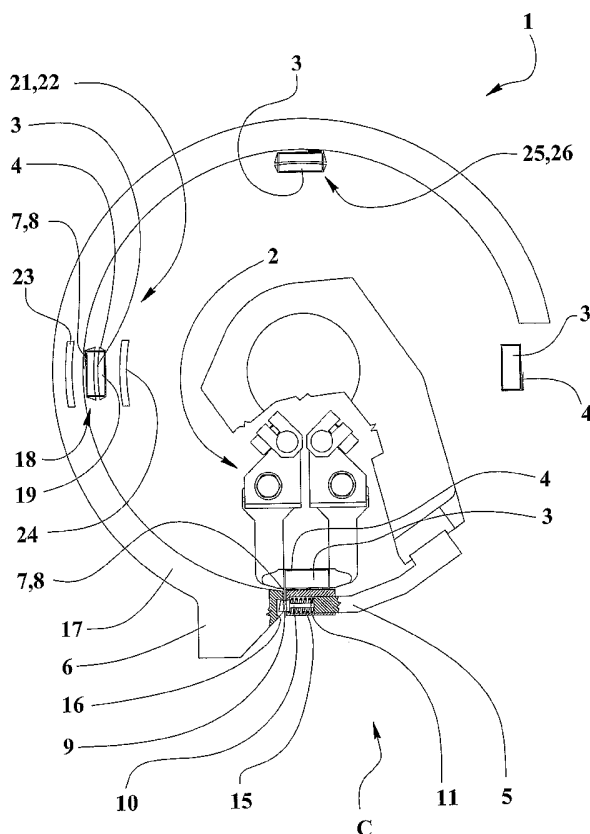

(57) Abstract: Device for wrapping an article comprising a holding mean (2) for the article (3) partially rolled-up by a wrapping foil material (4) and comprising at least two matching means, first (5) and second (6), mutually moving between a maximum mutual distanced condition (D), to interpose between them of the longitudinal flaps (7, 8) of said material (4) protruding from the article (3), and a mutual matching condition (C) to fold up and to join said longitudinal flaps (7, 8). The device comprises at least a cutting mean (9) protruding from the first matching mean (5) in the direction of the second matching mean (6) at least in the mutual matching condition (C) to carry out a cut in one or both the longitudinal flaps (7, 8) to facilitate the opening of the wrapping by an user.

WO 2006/111850 A1



RO, SE, SI, SK, TR), OAPI (BF, BJ, CF, CG, CI, CM, GA, GN, GQ, GW, ML, MR, NE, SN, TD, TG).

*For two-letter codes and other abbreviations, refer to the "Guidance Notes on Codes and Abbreviations" appearing at the beginning of each regular issue of the PCT Gazette.*

**Published:**

— *with international search report*

## WRAPPING DEVICE FOR ARTICLES AND WRAPPING METHOD

### TECHNICAL FIELD

5 The present invention refers to the field of packaging and it relates to a wrapping device for small articles, particularly for chocolates, bonbon, candy and the like and it relates to a method for wrap said articles.

### BACKGROUND ART

10

There are known devices for packing small articles, such as chocolates, sealing them in a sheet of material whose edges are hot or cold welded in order to obtain at least a partial airtight sealing.

15 A drawback of said devices consists in that the wrapping is very difficult to be opened; especially the children are not able to break the sheet of the wrapping.

Some of the known devices carry out transversal edges of the wrappings shaped in a zigzag manner or they carry out one or more opening score on the longitudinal edge of the  
20 wrapping.

A drawback of said known devices consists in that often the opening of the wrapping is not sufficiently easy.

25 Other drawback consists in that the zigzag shape of the edges characterizes in an undesirable manner the product and it limits the possible form and realization of the wrapping.

Some of the known devices made the final closure of the wrapping by making candy  
30 wrapper twist in portions of the wrapping material predisposed for the cold gluing.

Some drawbacks of these latter known devices consist in that they are very complicate and they increase the encumbrance of the machines associated thereto.

- 5 A drawback of these latter devices and methods are that they cannot provide a completely sealed wrapping allowing the passage of fluids through the interstices caused by the twists.

A drawback of the known wrapping methods to facilitate the opening of the wrapping envelope that can be carried out by means of said know devices, consist in that they can  
10 slow down the productivity of the devices.

#### DISCLOSURE OF THE INVENTION

An object of the present invention is to propose a device and a method to wrap articles,  
15 which can carry out opening score in simple and reliable manner to facilitate the opening of the wrapping to the users.

Other object is to propose a device and a method to carry out an airtight candy twist  
20 wrapping.

Further object is to propose a fast and simple wrapping method.

#### BRIEF DESCRIPTION OF THE DRAWINGS

25 The characteristics of the invention are highlighted in the following with particular reference to the enclosed drawings, in which:

- Figure 1 shows a schematic front and partial view of the device, object of the present invention, for wrapping articles, in a condition of making cuts on the edges of a  
30 material for the wrapping of an article;

- Figure 2 shows a partial and enlarged view of a detail of the device of Figure 1 in a condition of grasping the article and of the respective wrapping material, immediately precedent to the condition of the Figure 1;
- Figure 3 shows a side view of bending means of the device of Figure 1 with rotating pliers means and with articles to be wrapped in various wrapping conditions, in which some parts are removed to better evidence others,
- Figure 4 shows a front and enlarged view of a variant of a first matching mean of the device of the invention.

## 10 BEST MODE OF CARRYING OUT THE INVENTION

With reference to the figures 1 - 3, numeral 1 indicates the device of the present invention for wrapping an article, such as chocolates, candies, bonbon, praline or other articles, also non alimentary articles, for example having approximately to parallelepiped, cubic, prismatic forms and the like, also irregular forms.

The device 1 is preferably of rotating motion type, or with wrapper performed during a circular trajectory of the articles, and it comprises a holding mean 2, for example a rotating pliers with horizontal rotation axis having two jaws with the contacting portions oriented almost vertical in the holding phase of the article 3 partially enveloped by a wrapping foil material 4.

Particularly the material 4 is grasped in a manner to be shaped in form of "C" to contact three adjacent faces to the article 3 and with longitudinal flaps 7, 8, protruding quite a lot from said article 3, almost vertical disposed and mutually parallel.

The device 1 is also provided with two matching means, first 5 and second 6, reciprocally moving from a maximum distanced condition D, for allowing the interposition between them of the longitudinal flaps 7, 8 protruding from the article 3, to a mutual matching condition C to fold up and to join together said longitudinal flaps 7, 8.

The device 1 further comprises a cutting mean 9 sticking out, at least in the mutual matching condition C, from the first matching mean 5 in the direction of the second matching mean 6 to execute, in one or preferably in both the longitudinal flaps 7, 8, a cut to facilitate the user in opening the wrapping.

The invention provides that the cutting mean 9 comprise a straight blade or a shaped blade for example of "V" shape.

10 The device 1 includes guiding means 10, consisting, for example, of a small sliding shaft in a seat obtained in the first matching mean 5, to allow the sliding of the cutting mean 9 between a protruding condition P from the first matching mean 5 and an inner condition I in which the cutting mean is contained in a recess 11 of the first matching mean 5.

15 The device 1 is provided with first means elastic 15 acting on the cutting mean 9 with an elastic force in the direction of the second matching mean.

The device 1 comprises a movable beat mean 12 fixed to the first matching mean 5 in sliding manner toward the second matching mean 6 between an extended condition E, in which contains completely the cutting mean 9, and a re-entering condition R, in which the cutting mean 9 come out from the movable beat mean 12 through an opening 13 of this latter. The device 1 comprises second elastic means 14 acting on the movable beat mean 12 with an elastic force in the direction of the second matching mean.

25 The second matching mean 6 has a recess 16 fit to house a portion of the cutting mean 9 at least in the mutual matching condition C between the matching means 5, 6.

The invention provides that, when the wrapping foil material 4 with longitudinal flaps 7, 8 have cold adhesive thereon, the matching means are of the type for cold gluing, while when the wrapping foil material 4 is of thermo welding type, the matching means are of heated

type for hot welding.

The second matching mean 6 is fixed and it has annular sector shaped bending means 17 for keeping folded the two longitudinal flaps 7, 8 during the circular trajectory followed by the article during the wrapper.

The bending means 17 extends, in the rotating motion direction, at least up to a closure mean 18 for the transversal flaps 19, 20 of the material 4 protruding from the article 3, preferably up to the area in which the holding mean 2 release the wrapped article.

10

The closure mean 18 comprises two pliers 21, 22, for the closure of the transversal flaps 19, 20 of the material 4 vertically protruding out from the article 3, each provided with two jaws 23, 24 positioned on a plane nearly parallel to that defined by the rotary motion and nearly tangent to, or positioned on, circumferences centred on the rotation axis.

15

When the transversal flaps 19, 20 of the wrapping foil material 4 are provided with adhesive, the jaws 23, 24 of the pliers 21, 22 are of cold gluing type and when the wrapping foil material 4 is of thermo welding type, said jaws 23, 24 of the pliers 21, 22 are of heated type for hot welding.

20

The device comprises two rotating pincer means 25, 26 for holding and rotating the transversal flaps 19, 20 of the material 4 to carry out the candy wrapper twist.

25

The rotating pincer means 25, 26 are set downstream of the closure mean 18 in respect to the rotating motion direction.

The matching means 5, 6 are angularly spaced in respect to the closure mean 18 of about 90° and this last latter is angularly spaced in respect to the rotating pincer means 25, 26 of around 90°.

30

The rotation axes of the rotating pincer means 25, 26 are nearly perpendicular to the plane defined by the rotation motion.

The operation of the device according to the invention method to wrap an article provides:

- 5 – to grasp by means of a holding mean 2 the article 3 partially rolled up in a wrapping foil material 4 with the two longitudinal flaps 7, 8 thereof protruding from the article 3;
- to interpose the two protruding longitudinal flaps 7, 8 between two matching means first 5 and second 6 mutually moving and in a maximum mutual distanced condition D;
- to move reciprocally the two matching means first 5 and second 6 until to bring them in  
10 a mutual matching condition C to fold up and to joint said longitudinal flaps 7, 8;
- to make, almost contemporaneously to the folding of the flaps, at least a linear or V shaped cut, for facilitating the opening, in one or both said longitudinal flaps 7, 8 by means of a cutting mean 9 correspondingly shaped and protruding from the first matching mean 5 at least in the mutual matching condition C.

15

Furthermore the method provides to fix, by means of closure means 18, the transversal flaps 19, 20 of the material 4, sealing them perfectly, subsequently to the realization of the cut and to rotate the transversal flaps 19, 20 by means of rotating pincer means 25, 26 to subsequently realize knots after the fixing of the transversal flaps.

20

In the variant of figure 4, the device 1 comprises a movable beat mean 12 fixed to the first matching mean 5 in a manner sliding toward the second matching mean 6 between an extended condition E, in which contains completely the cutting mean 9, and a re-entering condition R, in which the cutting mean 9 comes out from the movable beat mean 12  
25 through an opening 13 of this latter, and to comprise second elastic means 14 acting on the movable beat mean 12 with an elastic force in the direction of the second matching mean.

The invention provides that the cutting mean 9 is rigidly fixed to the first matching mean 5 or, in alternative, that it is provided with the same or similar sliding means and with first  
30 elastic means described in the embodiment previously mentioned. In this case, the

invention provides that the first elastic means 15 acts a force bigger than the force of the second elastic means 14.

5 The adoption of the movable beat mean 12 avoid the contact of the cutting mean with the longitudinal flaps during the folding of these latter and it is preferable when it is necessary to avoid the risk to damage the wrapping of the article 3.

10 An advantage of the present invention is to provide a device and a method to wrap articles, which can carried out in simple and reliable manner cuts for opening score fit to facilitate the wrapper opening by an user.

Other advantage is to provide a device and a method for carrying out an airtight candy wrapping twist.

15 Further advantage is to provide a fast and simple wrapping method

Other advantage is to provide a method for carrying out a wrapping, which can allow the consumer to open the wrapper and consume the contents therein without touching said content by the hands.

20

CLAIMS

- 1) Device for wrapping an article comprising a holding mean (2) for the article (3) partially rolled-up by a wrapping foil material (4) and at least two matching means, first (5) and second (6), reciprocally moving between a maximum mutual distanced condition (D), to interpose between them the longitudinal flaps (7, 8) of said material (4) protruding from the article (3), and a mutual matching condition (C) to fold up and to join said longitudinal flaps (7, 8); said device being characterized in that it comprises at least a cutting mean (9) protruding, at least in the mutual matching condition (C), from the first matching mean (5) in the direction of the second matching mean (6) to carry out in one or both the longitudinal flaps (7, 8) a cut fit to facilitate the opening of the wrapper by an user.
- 2) Device according to claim 1 characterized in that it comprises guiding means (10) allowing the cutting mean (9) sliding between a protruding condition (P), in which it juts out of the first matching mean (5), and an inner condition (I) in which the cutting mean is housed in a recess (11) of the first matching mean (5) and in that it comprises first elastic means (15) acting on the cutting mean (9) with an elastic force in the direction of the second matching mean.
- 3) Device according to claim 1 characterized in that it comprises a movable beat mean (12) fixed to the first matching mean (5) in a manner sliding toward the second matching mean (6) between an extended condition (E), in which contains completely the cutting mean (9), and a re-entering condition (R), in which the cutting mean (9) comes out from the movable beat mean (12) through an opening (13) of this latter, and in that it comprises second elastic means (14) acting on the movable beat mean (12) an elastic force in the direction of the second matching mean.
- 4) Device according to claim 3 characterized in that the cutting mean (9) is rigidly fixed on the first matching mean 5.

- 5) Device according to claims 2 and 3 characterized in that the first elastic means (15) acts a force bigger then that of the second elastic means (14).
- 5 6) Device according to claim 1 characterized in that the second matching mean (6) has a recess (16) fit to house a portion of the cutting mean (9) at least in the mutual matching condition (C) between the matching means (5, 6).
- 10 7) Device according to claim 1 characterized in that when the wrapping foil material (4) has longitudinal flaps (7, 8) provided with adhesive, the matching means are cold gluing type.
- 8) Device according to claim 1 characterized in that when the wrapping foil material (4) is of thermo welding type, the matching means are of hot welding type.
- 15 9) Device according to claim 1 characterized in that it is of rotating motion type.
- 10) Device according to claim 9 characterized in that the second matching mean (6) is fixed and comprises ring segment shaped bending means (17).
- 20 11) Device according to claim 10 characterized in that the bending means (17) extends in the rotating motion direction at least until a closure mean (18) for the transversal flaps (19, 20) of the material (4), protruding from the article (3).
- 25 12) Device according to claim 11 characterized in that the closure mean (18) comprises two pliers (21, 22) for the closure of the transversal flaps (19, 20) of the material (4) protruding from the article (3), each pliers being provided with of two jaws (23, 24).
- 30 13) Device according to claim 12 characterized in that the jaws (23, 24) of each pliers (21, 22) are disposed on a plane nearly parallel to that defined by the rotary motion and

they are nearly tangent to, or disposed on, circumferences centred on the motion rotation axis.

- 5 14) Device according to claim 12 characterized in that when the wrapping foil material (4) is provided with adhesive transversal flaps (19, 20), the jaws (23, 24) of the pliers (21, 22) are of cold gluing type.
- 10 15) Device according to claim 12 characterized in that when the wrapping foil material (4) is thermo welding type, the jaws (23, 24) of the pliers (21, 22) are of hot welding type.
- 15 16) Device according to claim 1 characterized in that it comprises two rotating pincer means (25, 26) for holding the transversal flaps (19, 20) of the material (4) and for rotating said flaps to carry out candy wrapping twist.
- 20 17) Device according to claims 11 and 16 characterized in that the rotating pincer means (25, 26) are positioned downstream to the closure mean (18) in respect to the direction of the rotating motion.
- 25 18) Device according to claim 17 characterized in that the matching means (5, 6) are angularly spaced apart from the closure mean (18) of around 90° and this latter is angularly spaced apart from the rotating pincer means (25, 26) of around 90°.
- 30 19) Device according to claim 16 characterized in that the rotating pincer means (25, 26) are nearly perpendicular to the plane defined by the rotating motion.
- 20) Device according to claim 1 characterized in that the article (3) consists of a chocolate, in a bonbon, a candy, a praline or the like.
- 21) Method for wrapping an article by means of the device of any one of the preceding

claims characterized in that it provides:

- 5           – to grasp by means of a holding mean (2) the article (3) partially rolled up in a wrapping foil material (4) with the two longitudinal flaps (7, 8) protruding from the article (3);
  - to interpose the two protruding longitudinal flaps (7, 8) between two matching means, first 5 and second 6, reciprocally moving and in a maximum mutual distanced condition D;
  - 10          – to move mutually the two matching means, first (5) and second (6), until to bring them in a mutual matching condition (C) to fold up and to join said longitudinal flaps (7, 8);
  - to carry out, almost contemporaneously to the folding the flaps, at least a cut for facilitating the opening in one or both said longitudinal flaps( 7, 8) by means of a cutting mean (9) protruding from the first matching mean (5) at least in the mutual
  - 15          matching condition (C).
- 22) Method according to claim 21 characterized in that it comprises to carry out a linear or a “V” shaped cut by means of the cutting mean correspondingly shaped.
- 20   23) Method according to claim 21 characterized in that it comprises to fix the transversal flaps (19, 20) of the material (4) by means of closure means (18), sealing perfectly them, after the realization of the cut.
- 25   24) Method according to claim 23 characterized in that it comprises to rotate the transversal flaps (19, 20) by means of the rotating pincer means (25, 26) to carry out wrapping twist after the fixing of the transversal flaps.

1/4

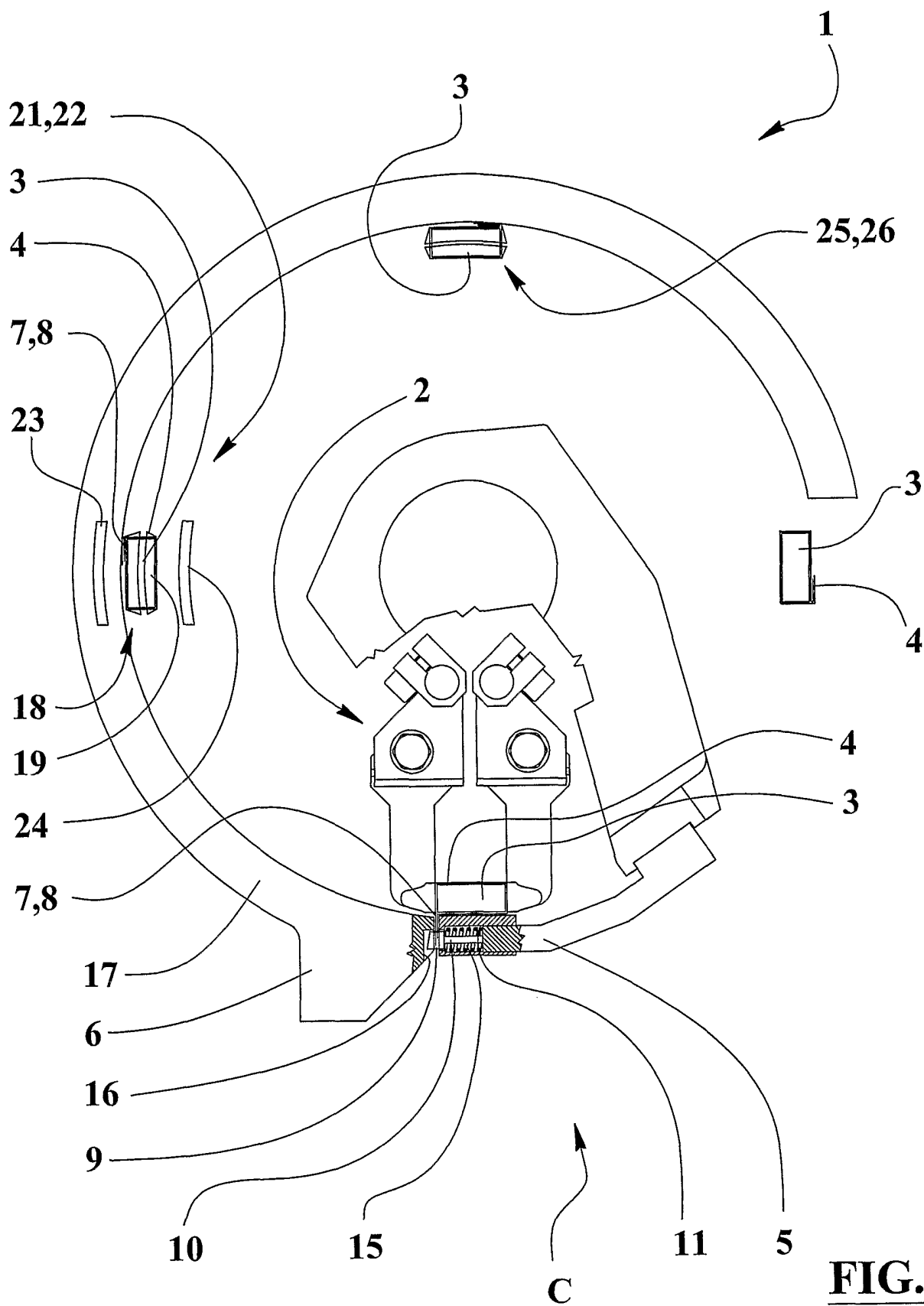

**FIG.1**





4/4

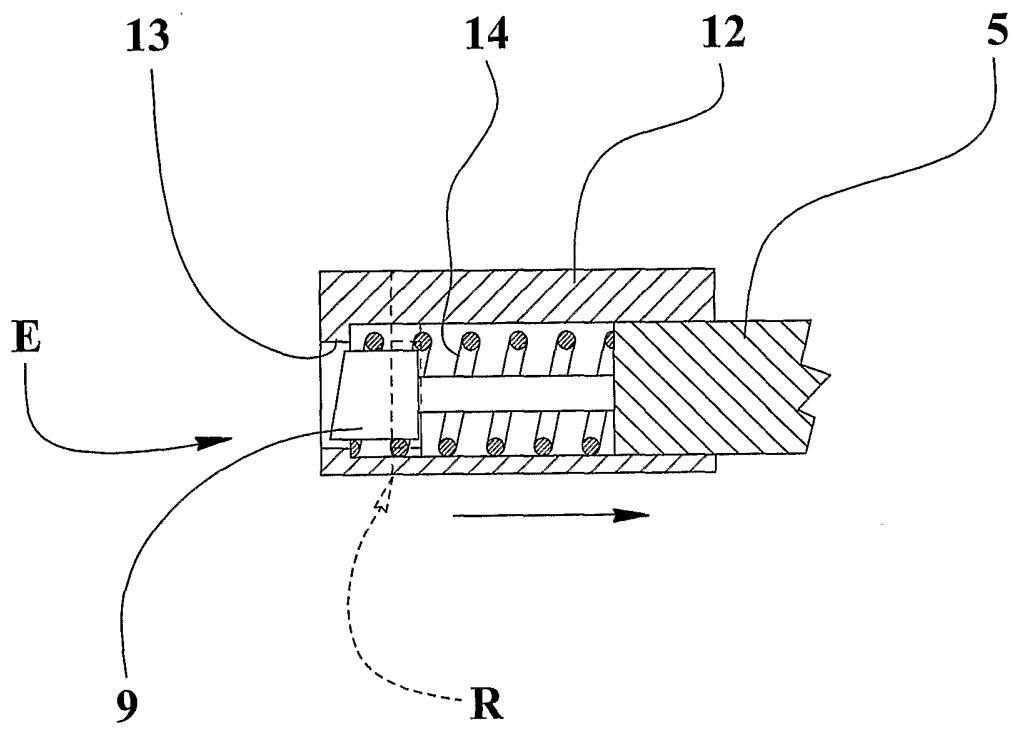

FIG.4

**INTERNATIONAL SEARCH REPORT**

International application No  
PCT/IB2006/001043

<b>A. CLASSIFICATION OF SUBJECT MATTER</b> INV. B65B11/34      B65B61/18      B65B25/00      B29C65/74				
According to International Patent Classification (IPC) or to both national classification and IPC				
<b>B. FIELDS SEARCHED</b> Minimum documentation searched (classification system followed by classification symbols) B65B B29C B65D				
Documentation searched other than minimum documentation to the extent that such documents are included in the fields searched				
Electronic data base consulted during the international search (name of data base and, where practical, search terms used)  EPO-Internal				
<b>C. DOCUMENTS CONSIDERED TO BE RELEVANT</b>				
Category*	Citation of document, with indication, where appropriate, of the relevant passages	Relevant to claim No.		
A	EP 0 816 229 A (PACTEC VERPACKUNGSMASCHINEN-FABRIK THEEGARTEN GMBH & CO. KG) 7 January 1998 (1998-01-07) column 4, line 46 - column 6, line 13; figures -----	1-24		
A	WO 03/106267 A (AZIONARIA COSTRUZIONI MACCHINE AUTOMATICHE; STIVANI, EROS; CAVALLARI,) 24 December 2003 (2003-12-24) abstract -----	1,21		
A	US 4 994 137 A (YANAI ET AL) 19 February 1991 (1991-02-19) column 4, line 11 - column 6, line 68; figures ----- -/--	1,21		
<table border="0" style="width:100%;"> <tr> <td style="width:50%;"><input checked="" type="checkbox"/> Further documents are listed in the continuation of Box C.</td> <td style="width:50%;"><input checked="" type="checkbox"/> See patent family annex.</td> </tr> </table>			<input checked="" type="checkbox"/> Further documents are listed in the continuation of Box C.	<input checked="" type="checkbox"/> See patent family annex.
<input checked="" type="checkbox"/> Further documents are listed in the continuation of Box C.	<input checked="" type="checkbox"/> See patent family annex.			
* Special categories of cited documents :				
"A" document defining the general state of the art which is not considered to be of particular relevance "E" earlier document but published on or after the international filing date "L" document which may throw doubts on priority claim(s) or which is cited to establish the publication date of another citation or other special reason (as specified) "O" document referring to an oral disclosure, use, exhibition or other means "P" document published prior to the international filing date but later than the priority date claimed	"T" later document published after the international filing date or priority date and not in conflict with the application but cited to understand the principle or theory underlying the invention "X" document of particular relevance; the claimed invention cannot be considered novel or cannot be considered to involve an inventive step when the document is taken alone "Y" document of particular relevance; the claimed invention cannot be considered to involve an inventive step when the document is combined with one or more other such documents, such combination being obvious to a person skilled in the art. "&" document member of the same patent family			
Date of the actual completion of the international search  <p align="center">5 July 2006</p>	Date of mailing of the international search report  <p align="center">08/08/2006</p>			
Name and mailing address of the ISA/ European Patent Office, P.B. 5818 Patentlaan 2 NL - 2280 HV Rijswijk Tel. (+31-70) 340-2040, Tx. 31 651 epo nl, Fax: (+31-70) 340-3016	Authorized officer  <p align="center">Philippon, D</p>			

# INTERNATIONAL SEARCH REPORT

International application No  
PCT/IB2006/001043

C(Continuation). DOCUMENTS CONSIDERED TO BE RELEVANT		
Category*	Citation of document, with indication, where appropriate, of the relevant passages	Relevant to claim No.
A	US 5 935 686 A (DAELMANS ET AL) 10 August 1999 (1999-08-10) column 5, line 45 - column 6, line 53; figures -----	1, 21

## INTERNATIONAL SEARCH REPORT

Information on patent family members

International application No

PCT/IB2006/001043

Patent document cited in search report		Publication date	Patent family member(s)	Publication date
EP 0816229	A	07-01-1998	DE 19626157 A1	02-01-1998
WO 03106267	A	24-12-2003	AU 2003239269 A1	31-12-2003
			BR 0311406 A	29-03-2005
			EP 1515892 A1	23-03-2005
			IT B020020390 A1	18-12-2003
			JP 2005529806 T	06-10-2005
			MX PA04012254 A	25-02-2005
			US 2005155329 A1	21-07-2005
US 4994137	A	19-02-1991	JP 1835060 C	11-04-1994
			JP 2032928 A	02-02-1990
			JP 5043576 B	02-07-1993
US 5935686	A	10-08-1999	AT 190287 T	15-03-2000
			AU 704044 B2	15-04-1999
			AU 7288396 A	28-07-1997
			BE 1009877 A3	07-10-1997
			BR 9608171 A	09-02-1999
			CA 2227735 A1	10-07-1997
			CN 1189137 A	29-07-1998
			CZ 289226 B6	12-12-2001
			CZ 9800055 A3	16-06-1999
			DE 69607044 D1	13-04-2000
			DE 69607044 T2	12-10-2000
			DK 929467 T3	31-07-2000
			EE 9700307 A	15-06-1998
			WO 9724273 A1	10-07-1997
			EP 0929467 A1	21-07-1999
			ES 2143234 T3	01-05-2000
			GR 3033520 T3	29-09-2000
			HK 1017872 A1	08-03-2002
			HU 9900140 A2	28-04-1999
			JP 2001515436 T	18-09-2001
			NO 975926 A	10-02-1998
			NZ 320186 A	28-10-1998
			PL 323588 A1	14-04-1998
			PT 929467 T	30-06-2000
			RU 2136560 C1	10-09-1999
			SK 9898 A3	06-05-1998
			TR 9701724 T1	21-05-1998
			ZA 9610893 A	27-06-1997