

J. F. MILLIGAN.
BALING PRESS.

No. 83,079.

Patented Oct. 13, 1868.

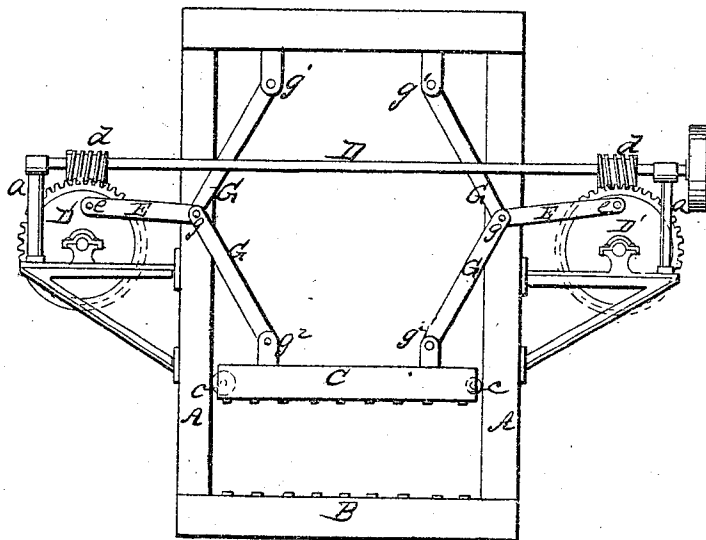

Witnesses.
Geo S. Kestler.

Geo W. Herbert

Inventor
John F. Milligan
by his attys
M. Randolph & Co.



JOHN F. MILLIGAN, OF ST LOUIS, MISSOURI.

Letters Patent No. 83,079, dated October 13, 1868.

IMPROVED BALING-PRESS.

The Schedule referred to in these Letters Patent and making part of the same.

To all whom it may concern:

Be it known that I, JOHN F. MILLIGAN, of St. Louis, in the county of St. Louis, and State of Missouri, have made certain new and useful Improvements in Baling-Presses; and I do hereby declare that the following is a full and clear description thereof, reference being had to the accompanying drawings, and to the letters of reference marked thereon.

This invention relates to a new combination of the toggle-joint and progressive lever, for the purpose of operating the movable platen of a baling-press.

To enable those skilled in the art to make and use my improved press, I will proceed to describe its construction and operation.

The accompanying drawings represent a sectional elevation of the improved press. The frame A may be of any desired form of construction that may be found adapted to the style of press herein represented. The stationary platen B, and the movable platen C, may also be of any desired form of construction. The driving-shaft D will have its bearings provided in the hangers a, attached to the frame A, and each end of the said shaft will be provided with endless screw-threads d, which will gear into and actuate the cogged sectors D'. The links or connecting-rods E will be attached to the sectors by means of the wrist-pins e, and also to the joint-pin g, of the toggle-joint rods G. This arrangement of the sectors and connecting-rods gives all the benefits derived from the use of the progressive lever of the Tyler and other presses. The fixed ends of the rods G are provided with bearings in the joint-blocks g', which are attached to the frame A, and form the fulcrum against which the pressure is exerted to compress the bale. A joint-block, g'', similar to the blocks g', is fixed to the platen C, for each of the movable ends of the rods G.

In the operation of a press constructed as above described, the sectors and rods E, act with a progressive leverage, and the toggle-joint rods G, act in concert with the greatest force at the moment of ultimate strain or pressure upon the bale.

The press herein described may be considered as a double-acting or double-gearred press. A single-gearred press of equivalent construction might be produced by the use of only one sector, D', and rod E, by turning both of the toggle-joints in the same direction, and using a connecting-rod between the two knuckles of the toggle-joint rods.

If used as a single-gearred press, it would become necessary to place friction-sheaves, c, at the ends of the platen C, for the purpose of reducing the excessive lateral pressure that would, by such construction, be produced. It would, however, be beneficial to use the said sheaves c at all times, and in all forms of construction.

I am aware that all the several devices herein described, considered separately, are old and well known; and, further, that the combination of a screw-shaft, worm-wheel or sectors, connecting-rods, and the platens of a press, is not new, but has been described in patents already issued; hence I do in nowise claim said individual devices, nor the combination before mentioned; but

What I do claim as my invention is—

Combining the screw-threaded shaft D, sectors D', and platen C, the toggle-levers G, and rods E, in the manner herein shown and described.

JOHN F. MILLIGAN.

Witnesses:

M. RANDOLPH,
H. M. SUMNER.