



(12) **EUROPEAN PATENT APPLICATION**

(43) Date of publication:
02.01.2019 Bulletin 2019/01

(51) Int Cl.:
A62C 13/76 (2006.01)

(21) Application number: **18188594.8**

(22) Date of filing: **04.12.2012**

(84) Designated Contracting States:
AL AT BE BG CH CY CZ DE DK EE ES FI FR GB GR HR HU IE IS IT LI LT LU LV MC MK MT NL NO PL PT RO RS SE SI SK SM TR

(30) Priority: **06.12.2011 GB 201120907**

(62) Document number(s) of the earlier application(s) in accordance with Art. 76 EPC:
12195557.9 / 2 620 183

(71) Applicant: **UTC CCS Manufacturing Polska Sp. z o.o.**
39-100 Ropczyce (PL)

(72) Inventors:
• **MAY, John James**
Kenilworth, Warwickshire CV8 1BS (GB)

• **FERNANDES, Mark Anthony John**
Leamington Spa, Warwickshire CV32 6EW (GB)
• **RUTTER, Paul Benedict**
Warwick, Warwickshire CV34 4UJ (GB)
• **FLETCHER, Peter George**
Chobham, Surrey GU24 8HD (GB)
• **FERGUSON, Chris John**
Burton on Trent, Staffordshire DE15 9HL (GB)

(74) Representative: **Dehns**
St. Brides House
10 Salisbury Square
London EC4Y 8JD (GB)

Remarks:

This application was filed on 10.08.2018 as a divisional application to the application mentioned under INID code 62.

(54) **FIRE EXTINGUISHER SAFETY MECHANISM**

(57) A fire extinguisher safety mechanism (4) comprises a release member (16) and an indicator member (18). The release member (16) is configured for lengthwise insertion and withdrawal from between the handles (8, 10) of a fire extinguisher (2). It has a proximal end (38) for gripping by a user and a distal end (46) having an aperture (56). The indicator member (18) has a head (60) and a shank (62) projecting from the head (60). The distal end (80) of the shank has resilient retaining teeth (84). The indicator member (18) is configured to be mounted to the extinguisher 2 with its shank (62) passing through an aperture (71) in the extinguisher (2) and through the aperture (56) in the distal end (46) of the release member (16) so as to be retained relative to the release member (16) by said resilient retaining teeth and to prevent accidental withdrawal of the release member (16) from between the handles (8, 10).

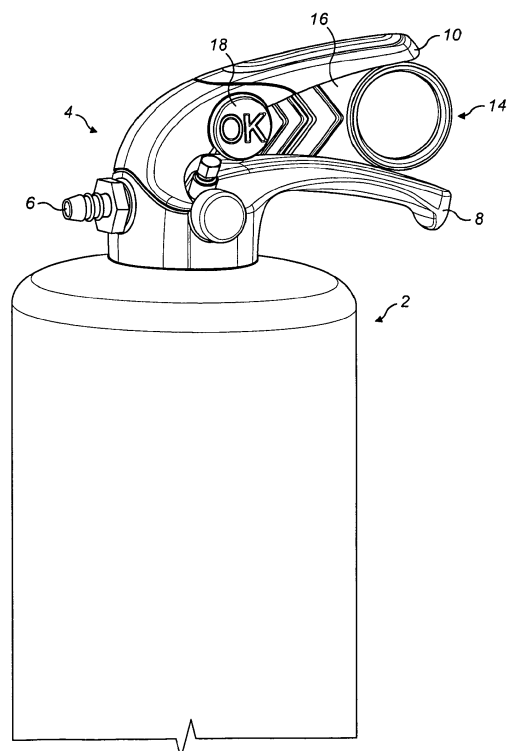

FIG. 1

Description

FIELD OF INVENTION

[0001] The present invention relates to fire extinguishers and in particular to fire extinguisher safety mechanisms.

BACKGROUND

[0002] Fire extinguishers frequently include a safety mechanism which prevents accidental discharge of the extinguisher. One such mechanism comprises a pin which extends through the handle of the extinguisher. The pin has a handle at one end which can be pulled by a user when he or she wishes to use the extinguisher. The pulling action breaks a part of the pin allowing it to be withdrawn from the extinguisher handle and allowing the extinguisher then to be used. The broken pin also indicates that the extinguisher has been used. An example of such an extinguisher is disclosed in US-A-3844356.

[0003] In a similar system, the end of the pin remote from the pin handle is provided with a weakened head which engages a pronged opening in a seal. When the pin is withdrawn the seal breaks, allowing the pin to be withdrawn and the extinguisher to be used. The damaged caused to the seal indicates that the extinguisher has been used. Such a system is disclosed in US-A-3 666 016.

[0004] In a variation on that design, the end of a pin remote from the pin handle is weakened such that when it is pulled from the extinguisher it breaks, allowing an indicator member to fall away. This indicates that the extinguisher has been used. This type of design has been used by the Applicant for some 20 years.

[0005] A problem with such designs is that the pin handle projects from one side of the extinguisher body, i.e. it is a "handed" arrangement which may be inconvenient for a user. A further problem is that the pin breaks in tension which may make construction of the pin more difficult or breaking of the pin more difficult.

[0006] The present invention seeks to overcome or at least mitigate the above problems.

SUMMARY

[0007] According to a first aspect of the present invention, there is provided an indicator member for a fire extinguisher safety mechanism comprising a disc-like head portion, a shank projecting from the head portion, said shank having an intermediate region provided with an area of weakness and a distal end provided with resilient retaining means.

[0008] The area of weakness may comprise a hole. The hole may extend through a waisted area of the shank. The shank may include a tapered proximal portion.

[0009] The resilient retaining means provided on the

distal end of the shank comprises barbs formed on the end of flexible legs formed by a slot in the distal end of the shank.

[0010] The indicator member may be brightly coloured, fluorescent, luminescent or phosphorescent.

[0011] The dimensions of the waisted area and hole may be such that the shank can break in shear under an applied force of less than 100N.

[0012] A rear surface of the head may be provided with one or more ribs for assisting in the appropriate orientation of the indicator member.

[0013] The indicator member may be moulded polystyrene.

[0014] From a second aspect the present disclosure provides a fire extinguisher safety mechanism. The mechanism comprises a release member configured for lengthwise insertion and withdrawal from between the handles of a fire extinguisher. The release member has a proximal end and a distal end. The proximal end is intended to be gripped by a user. The distal end has an aperture. The mechanism further comprises an indicator member. The indicator member has a head, a shank projecting from said head and a distal end with resilient retaining means. The indicator member is configured to be mounted to the fire extinguisher with its shank passing both through an aperture in the head of the extinguisher (for example in the movable handle of the extinguisher) and the aperture in the distal end of the release member. The resilient retaining means retains the indicator member relative to the release member and also prevents accidental withdrawal of the release member from between the handles.

[0015] In accordance with the disclosure, therefore, rather than a user operating the extinguisher by pulling a release mechanism from one side of the extinguisher, the user pulls a release member lengthwise from between the handles. Pulling the release member in this manner will cause the shank of the indicator member to shear, allowing the release member to be removed from between the handles. One of the handles can then be moved relative to the other to operate the extinguisher. The indicator member will no longer be retained and will simply fall away indicating that the extinguisher has been used. As its shank has been sheared, it cannot be used again.

[0016] The head of the indicator member may be relatively thin and may for example be disc like. It may be circular in shape or have any desired shape, for example a polygonal shape.

[0017] The head may carry an inscription, for example "OK", to indicate that the extinguisher has not been used.

[0018] To enhance visibility of the indicator member in low light conditions, the indicator member may be brightly coloured. It may be made from a fluorescent, phosphorescent, luminescent or other 'glow in the dark' material. The colour of the indicator may be varied to, for example, indicate its year of manufacture or servicing of the extinguisher, thereby giving the user an indication of the period

in which the extinguisher has not been operated. Up to 20 wt% of a coloured and/or luminous additive may be added to the material of the indicator.

[0019] The indicator member may be moulded from a plastics material, for example a polystyrene material. The material should desirably be chosen such that the shank of the indicator member shears without excessive strain, i.e. such that it does not stretch excessively. If the material stretches, it will break in tension rather than in shear which is undesirable since the force required to break the shank would typically be twice as high in tension as in shear. A desirable breaking force in some applications is less than 100N, for example below 80N.

[0020] To provide the requisite material properties, regrind (particularly of the same material of the virgin material) may be added to the virgin material. This reduces the strength of the virgin material. In one example, between 2-10 wt% regrind, more narrowly 4-6 wt%, for example 5% regrind may be used. A material which has proven particularly suitable is EDISTIR N1840, with 5 wt% EDISTIR N1840 regrind.

[0021] The indicator member head may be configured to be received by a complementary area provided on the extinguisher head, more particularly an area on the movable handle of the extinguisher. That area may carry an inscription such as "USED" which becomes visible once the indicator member head has fallen away, thereby indicating that the extinguisher has been used. The inscription may be embossed, printed or otherwise provided on the extinguisher head.

[0022] In order to facilitate shearing of the indicator member shank, the shank may be provided with one or more areas of weakness. This area of weakness may be in an intermediate region of the shank.

[0023] In one arrangement, the shank is provided with a through hole which effectively reduces the thickness of the shank. Other arrangements are possible, however, for example a waisting of the shank in the region of its engagement with the release member. In one arrangement, a through hole may be provided in a waisted region of the shank. This not only reduces the force necessary to shear the shank but also to improve flow of material in the mould during the moulding of the indicator member.

[0024] The shank may be stepped in order to provide a first region for engaging in the aperture provided in the extinguisher head and a second region, smaller in cross section than the first region, for engaging in the aperture provided in the release member.

[0025] In another embodiment, however, a proximal portion of the shank adjacent the head may taper towards the distal end of the shank. This avoids a columnar shank which potentially could be reinserted in the aperture in the extinguisher head after use, which is undesirable.

[0026] The resilient retaining means provided on the distal end of the shank may be barb-like, for example formed on the ends of flexible legs formed by a slot in the distal end of the shank. The barbs prevent the indicator member being withdrawn from the release member

once the indicator member has been inserted.

[0027] The distal end of the shank may have a profile which is at least in part complementary to that of the aperture in the distal end of the release member. This is advantageous in that it helps locate the indicator in the release member and reduces twisting of the shank as the release member is withdrawn, thereby reducing the chances of the shank breaking in tension rather than in shear.

[0028] In the arrangement described immediately above, the lateral surfaces of the flexible legs of the retaining means may be formed as flat surfaces, particularly parallel flat surfaces, to cooperate with complementary surface in the aperture in the release member.

[0029] Alignment means may be provided to align the indicator member in an appropriate orientation on the extinguisher, so that, for example, any inscription is easily readable by a user. In one arrangement, the rear surface of the head of the indicator member is provided with a formation, for example one or more projections which engages with a corresponding formation on the extinguisher. In one example, the rear surface of the head is provided with a rib which engages under the lower edge of the handle to which the indicator member is mounted.

[0030] As discussed above, once the extinguisher has been used the indicator member is broken and, once the extinguisher is re-charged, must be replaced. The present disclosure therefore also extends to an indicator member per se.

[0031] The indicator member may have one or more of the various optional features described above.

[0032] Turning to the release member, the proximal end thereof may comprise an aperture through which a user may place one or more fingers to pull the release member from between the extinguisher handles.

[0033] The distal end of the release member may be provided with a clip for engaging a part of the extinguisher handle or a part of the extinguisher valve mechanism to assist in retaining the release member in position. This may take some load off the shank of the indicator member in the event of a force being applied accidentally to the release member.

[0034] As discussed above, the aperture in the distal end of the release member may be at least in part complementary in shape to the distal end of the indicator shank.

[0035] The distal end of the release member may be provided with a boss, offset from the main plane of the release member. The boss is provided with the aperture for receiving the shank of the indicator member. This may allow the shank of the indicator member to be shorter in length, leading to improved strength and stability. It may also prevent or reduce external access to the shank.

[0036] The release member is shaped to be received between the fixed and movable handles of the fire extinguisher operating mechanism. Both handles may be provided with longitudinally extending formations for example grooves or ribs to locate the release mechanism. The

release member may then be provided with complementary formations.

[0037] The release member may be moulded from a plastics material such as polypropylene and it may be brightly coloured, luminescent, fluorescent etc. as the indicator member. It may be formed from different colours to reflect the type of extinguishing material held in the extinguisher, e.g. water, foam or powder. Up to 20 wt% of a coloured and/or luminous additive may be added to the material of the indicator.

[0038] The invention also extends to a fire extinguisher including a safety mechanism as discussed above.

[0039] In the described embodiment, the aperture for receiving the shank of the indicator member is provided on the movable handle of the extinguisher.

[0040] An embodiment of the invention will now be described by way of example only with reference to the accompanying drawings.

BRIEF DESCRIPTION OF THE DRAWINGS

[0041]

Figure 1 is a perspective view of a fire extinguisher incorporating a safety mechanism in accordance with the invention;

Figure 2 is a side elevation of the release member of the safety mechanism;

Figure 3 is a top view of the release member of Figure 2;

Figure 4 is a front view of the release member of Figure 2

Figure 5 is a side view of the movable handle of the fire extinguisher of Figure 1;

Figure 6 is a bottom view of the handle of Figure 5;

Figure 7 is a perspective view of the fixed handle of the fire extinguisher of Figure 1

Figure 8 is a front perspective view of the indicator member of the safety mechanism;

Figure 9 is a rear perspective view of the indicator member of Figure 8;

Figure 10 is a side view of the indicator member of Figure 8; and

Figure 11 is a top view of the indicator member of Figure 8.

DETAILED DESCRIPTION OF AN EMBODIMENT

[0042] With reference to Figure 1, a fire extinguisher 2 comprises a head 4 having a ferrule 6 for the attachment of a hose (not shown). The head 4 comprises a fixed handle 8 and a movable handle 10 which is pivotably mounted to the fixed handle 8 about a pivot (not shown) in a known manner. As is known in the art, downward movement of the movable handle 10 presses on an actuating pin (not shown) which opens a valve to release fire suppressant, e.g. water, foam or powder through the head 4 and ferrule 6.

[0043] To avoid inadvertent operation of the extinguisher, a safety mechanism 14 is provided. The safety mechanism 14 comprises a release member 16 and an indicator member 18.

[0044] The release member 16 is moulded from a plastics material, e.g. polypropylene, and is elongate. It is received between the movable and fixed handles 8, 10. As can be seen from Figures 2 to 4, the release member 16 has a generally planar web 20 with a relatively narrow flange 22 provided around its periphery, in particular along its upper edge 24, and a relatively wide flange 26 provided along its lower edge 28. A rib 30 projects downwardly from the relatively wide flange 26.

[0045] The relatively narrow flange 22 is received within a groove 32 provided on the lower surface 34 of the movable handle 8, and the rib 30 is received in a groove 36 provided on an upwardly facing surface 37 of the fixed handle 10. The interengagement of the flange 22 in groove 32 and rib 30 in groove 36 provides lateral support for the release member 16.

[0046] The proximal end 38 of the release member 16 is provided with a circular opening 40 through which a user may insert one or more fingers. The middle section 42 of the web 20 is provided with arrow like openings 44 which indicate to the user the direction of operation of the release member 16.

[0047] The distal end 46 of the release member 16 comprises a resilient clip 48 which in use engages around a post provided in the movable handle 8.

[0048] Also provided at the distal end 46 of the release member 16 is an L-section boss 50. The boss 50 has a forwardly projecting flange 52 the distal end 54 of which is provided with an opening 56. The opening 56 is generally circular in shape, but with straight sides 58. The opening 56 receives the indicator member 18, which is described with reference to Figures 8 to 10.

[0049] The indicator member 18 is moulded from a plastics material such as polystyrene. In one embodiment, the material may be EDISTIR N1840 with 5 wt% regrind. It may be brightly coloured and may be fluorescent or phosphorescent.

[0050] It comprises a relatively thin, disk-shaped head 60 and a shank 62 projecting from the rear surface 64 of the head 60. Although shown as circular, the head 60 may of course have any convenient shape, for example polygonal.

[0051] The front surface 66 of the head 60 is provided with a recessed inscription 68 ("OK" in the illustrated embodiment) which will be seen by a user when the indicator member 18 is *in situ*.

[0052] The rear surface 64 of the head 60 is generally planar for engaging and covering a complementary area 70 of the movable handle 8. As can be seen from

[0053] Figure 5, this area 70 bears an inscription 72, in this embodiment "USED", so that when the area 70 is exposed, the user will know that the extinguisher has been used. Of course some other wording may be used, for example "used" in other languages. That area 70 also

includes an opening 71 for receiving the shank 62 of the indicator member 18.

[0054] The rear surface 64 of the head 60 also comprises a rib 74 which in use engages under a portion of the lower edge 76 of the movable handle 8 to assist in the orientation of the indicator member 18 so that the inscription 68 is the correct way up.

[0055] The shank 62 is provided with a slot 78 at its distal end 80, thereby defining two resilient legs 82. Each leg 82 is provided with a barbed tooth 84 at its distal end. The lateral surfaces 86 of each leg 82 are formed as flat surfaces for engagement with the sides 58 of the opening 56 in the distal end of the release member 16. The surfaces 86 stand proud of the surrounding surface, as can be seen most clearly from Figure 11. The upper and lower surfaces 88 of the legs 82 are generally circular in section and of a diameter smaller than the circular sections of the opening 56.

[0056] The shank 62 has a tapering proximal section 90 and a transversely waisted intermediate section 92. An opening 94 is provided through the intermediate section 92 to provide a well defined area of weakness in the shank 62. The dimensions of the waisting and opening 94 are chosen such that the shank can break in shear under an applied force of less than 100N. The maximum diameter of the proximal and intermediate sections 90, 92 is smaller than the diameter of the opening 71 provided in the area 70 of the movable handle 8 to allow the shank 62 to be received therein.

[0057] Installation and operation of the safety mechanism 14 will now be described. As a first step, the release member 16 is inserted longitudinally into position between the handles 8, 10. The flange 22 and the rib 30 provided on the release member 16 and the grooves 32, 36 formed in the handles 8, 10 guide the release member 16 appropriately. The release member 16 is pushed into the space between the handles 8, 10 until the clip 48 engages with the valve pin. In this position, the opening 56 at the distal end of the release member 16 is aligned with the opening 71 provided in the movable handle 10. The relatively wide flange 26 of the release member 16 generally follows the contour of and covers the upper surface 37 of the fixed handle 8.

[0058] The indicator member 18 can then be mounted. The shank 62 of the indicator member 18 is pushed through the opening 71 in the movable handle 8 and the aligned opening 56 in the release member 16. The resilience of the legs 82 of the shank 62 allow the barbed teeth 84 to deflect inwardly as the shank 62 is pressed in, and then spring back when the teeth 84 have passed through the openings 71, 56 preventing the indicator member 18 from being withdrawn through the openings. The flat lateral surfaces 86 of the legs 82 engage closely with the straight sides 58 of the opening 56. This will help prevent twisting of the shank 62 as the release member is pulled out.

[0059] Proper orientation of the head 60 is ensured by interengagement of the rib 74 of the head 60 and the

lower edge 76 of the movable handle 8.

[0060] When the indicator member 18 is so inserted, the user will see from the "OK" inscription 68 that the extinguisher is ready to use. Should the user inadvertently press on the movable handle 8, operation of the extinguisher is prevented by the release member 16 which prevents the movable handle 8 moving towards the fixed handle 10. Moreover, any small force acting to pull the release member 16 rearwardly from between the handles 8, 10 will be resisted by the shank 62 of the indicator member and by the clip 48.

[0061] In the event of a fire, however, the user pulls the release member 16 from between the handles 8, 10 in the direction indicated by the arrow openings 44. The pulling action causes the weakened intermediate section 92 of the shank 62, which is within the opening 56 in the release member 16, to shear, allowing the release member 16 to be withdrawn. The release member 16 pulls the distal end 80 of the shank 62 away with it so that it does not interfere with operation of the extinguisher. The head 60 of the indicator member 18 simply falls away, no longer being retained by its shank 62. The extinguisher 2 can then be used in the normal way.

[0062] After use, it will be clear to potential other users that the extinguisher has been used since the "USED" inscription 72 is visible.

[0063] After the extinguisher 2 has been recharged, a new safety mechanism 14 may be installed. The relatively robust release member 16 is not damaged in use and so may be re-used. However, a new indicator member 18 will have to be provided. The tapering of the proximal portion 90 of the shank 62 of the indicator member 18 means that the used indicator member 18 cannot simply be pushed into the opening 71 in the handle 8, as it will simply fall out. This would be undesirable since a user would then not be able to determine with certainty whether an extinguisher had been used or not. However, as the indicator member 18 is a moulding, it is relatively inexpensive to replace.

[0064] It will be understood that the above is a description of just one possible embodiment of the invention and that various modifications may be made to the embodiment without departing from the scope of the invention as defined by the following claims.

Claims

1. An indicator member (18) for a fire extinguisher safety mechanism comprising:

a disc-like head portion (60);
 a shank (62) projecting from the head portion (60);
 said shank (62) having an intermediate region (92) provided with an area of weakness and a distal end (80) provided with resilient retaining means.

2. An indicator member as claimed in claim 1 wherein the area of weakness comprises a hole (94).
3. An indicator member as claimed in claim 2 wherein the hole (94) extends through a waisted area of the shank (62). 5
4. An indicator member as claimed in any preceding claim wherein the shank (62) includes a tapered proximal portion (90). 10
5. An indicator member as claimed in any preceding claim wherein the resilient retaining means provided on the distal end (80) of the shank (62) comprises barbs (84) formed on the ends of flexible legs (82) formed by a slot (78) in the distal end (80) of the shank (62). 15
6. An indicator member as claimed in any preceding claim wherein the indicator member (18) is brightly coloured, fluorescent, luminescent or phosphorescent. 20
7. An indicator member as claimed in any of claims 3 to 6 wherein the dimensions of the waisted area and hole (94) are such that the shank (62) can break in shear under an applied force of less than 100N. 25
8. An indicator member as claimed in any preceding claim wherein a rear surface (64) of the head (60) is provided with one or more ribs (74) for assisting in the appropriate orientation of the indicator member (18). 30
9. An indicator member as claimed in any preceding claim wherein the indicator member is moulded polystyrene. 35
10. A fire extinguisher safety mechanism comprising: 40
- a release member (16) configured for lengthwise insertion and withdrawal from between the handles (8, 10) of a fire extinguisher (2), said release member (16) having a proximal end (38) and a distal end (46), said proximal end (38) for gripping by a user and said distal end (46) having an aperture (56); and 45
- an indicator member (18) as claimed in any preceding claim, 50
- said indicator member (18) being configured to be mounted to said extinguisher (2), with its shank (62) passing through an aperture (71) in the head (4) of said extinguisher (2) and through said aperture (56) in said distal end (46) of said release member (16) so as to be retained relative to said release member (16) by said resilient retaining means and for preventing accidental withdrawal of said release mem- 55
- ber (16) from between the handles (8, 10).
11. A fire extinguisher comprising the fire extinguisher safety mechanism as claimed in claim 10.

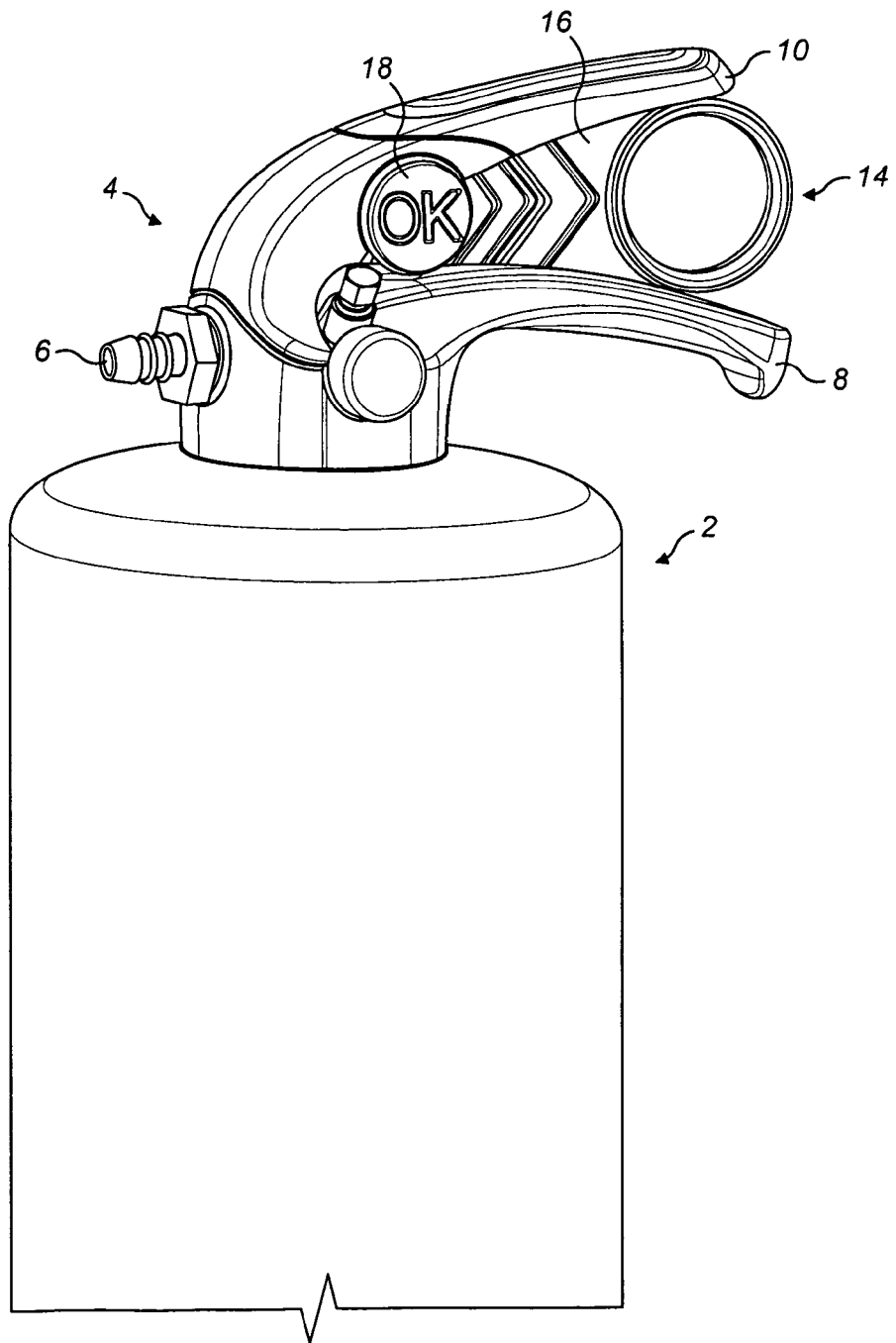

FIG. 1

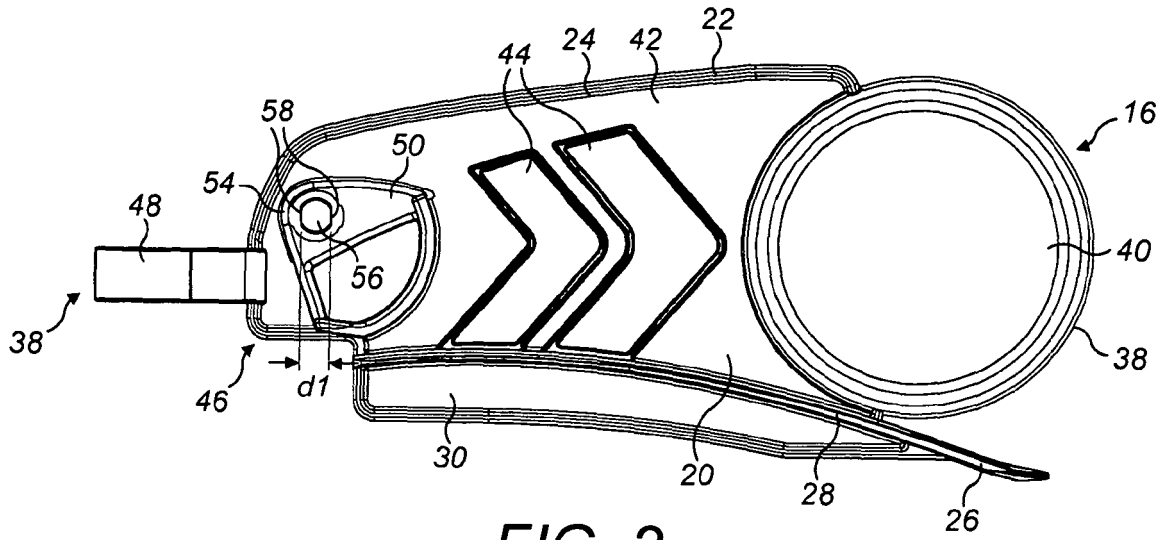

FIG. 2

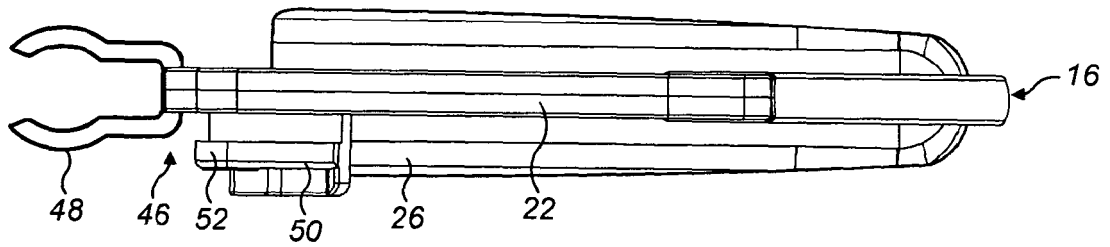

FIG. 3

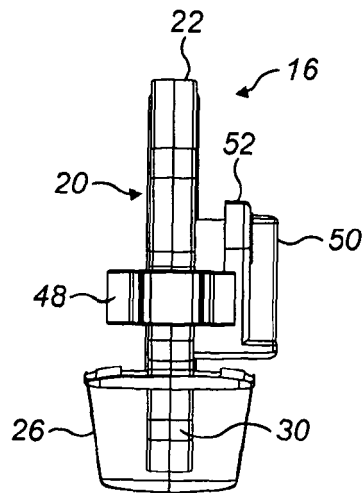

FIG. 4

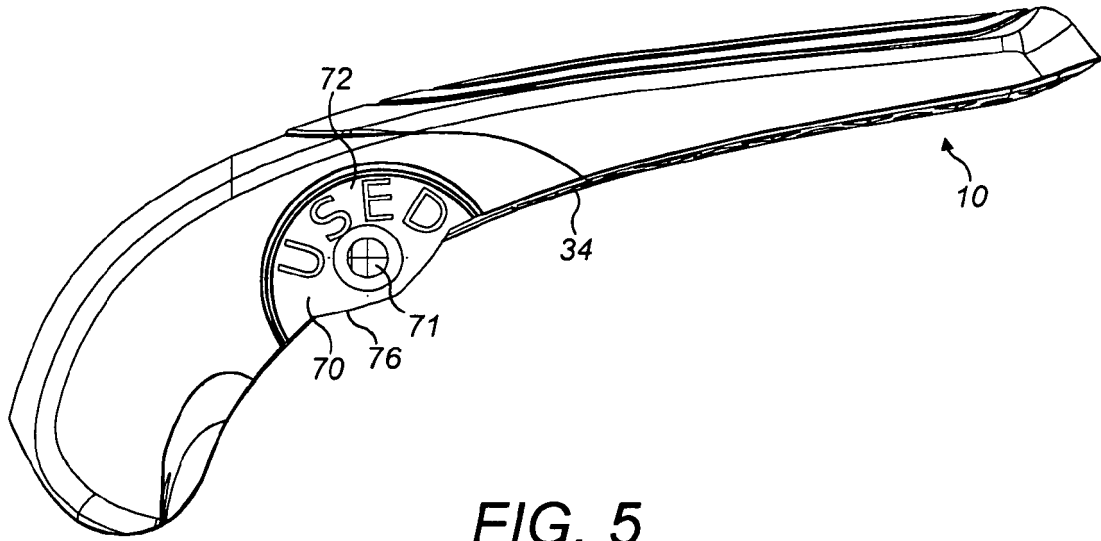

FIG. 5

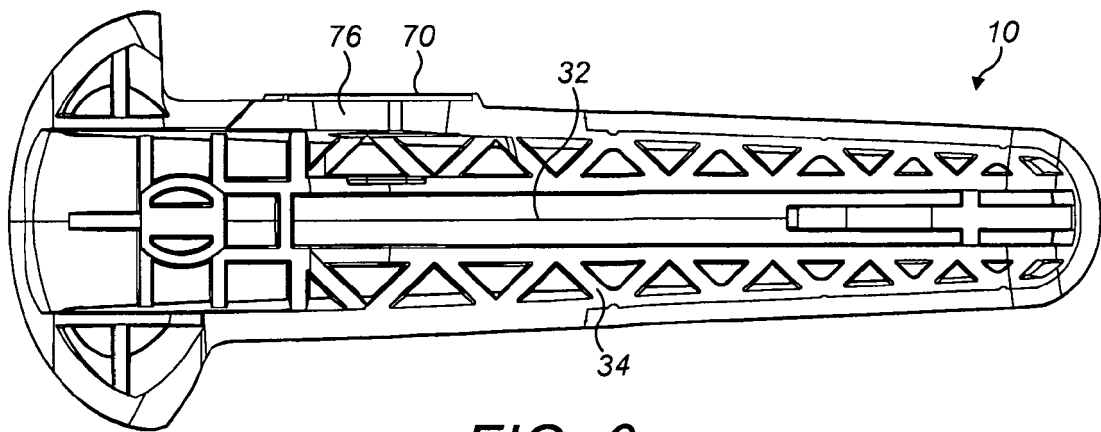

FIG. 6

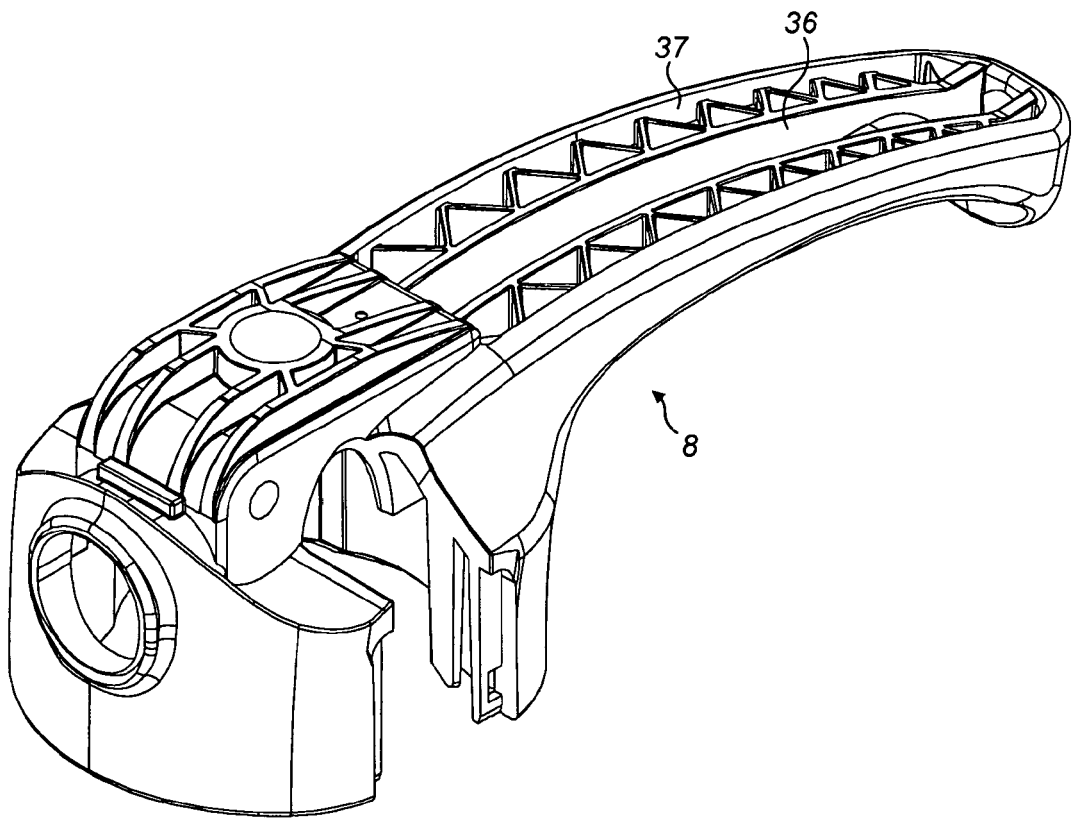

FIG. 7

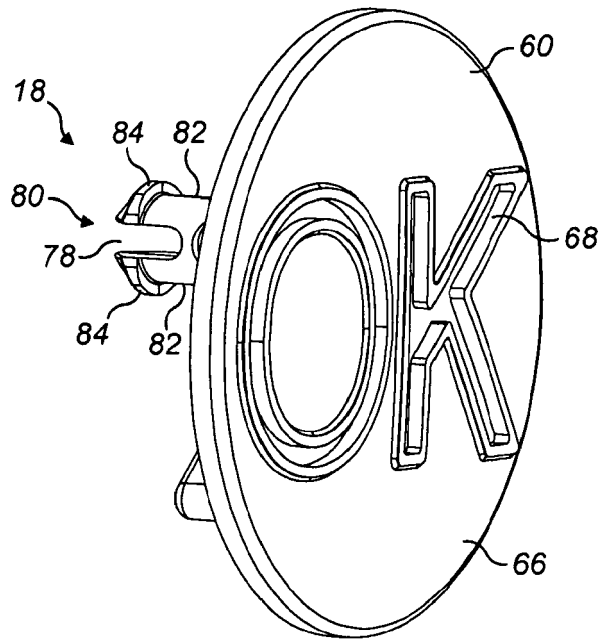

FIG. 8

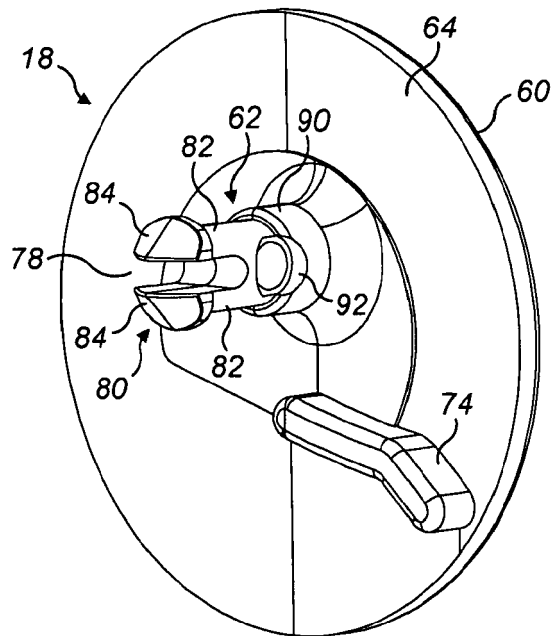

FIG. 9

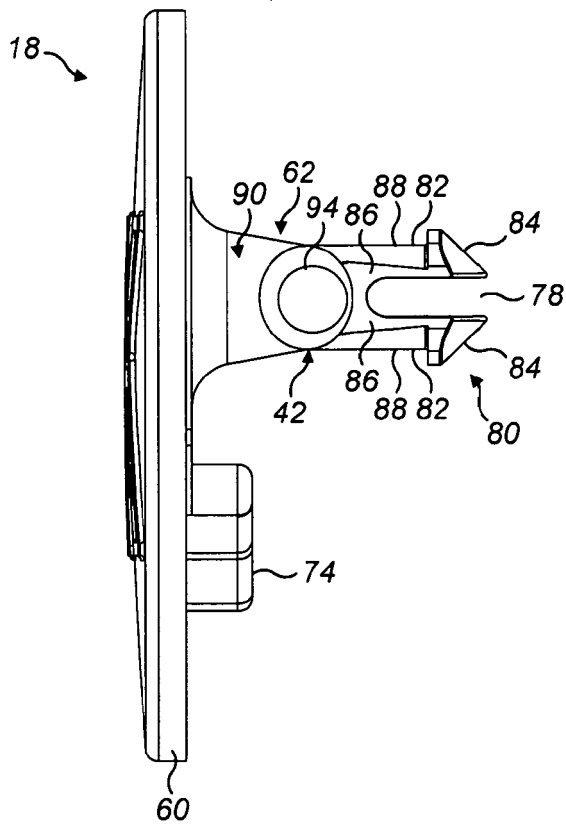

FIG. 10

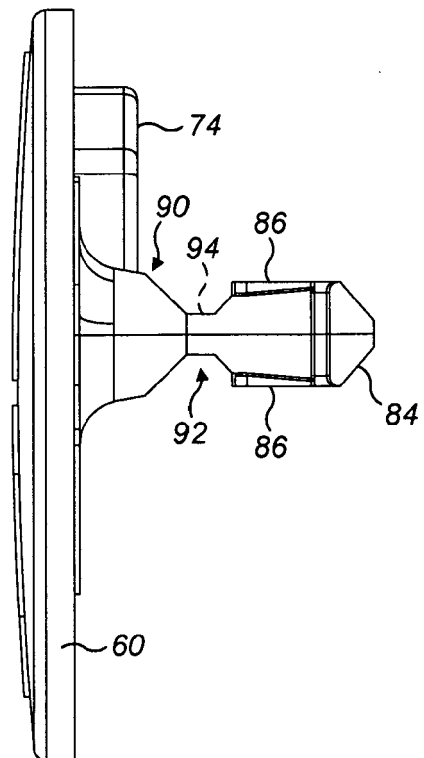

FIG. 11



EUROPEAN SEARCH REPORT

Application Number
EP 18 18 8594

5

10

15

20

25

30

35

40

45

50

55

DOCUMENTS CONSIDERED TO BE RELEVANT			
Category	Citation of document with indication, where appropriate, of relevant passages	Relevant to claim	CLASSIFICATION OF THE APPLICATION (IPC)
X	JP S50 59894 U (UNKNOWN) 3 June 1975 (1975-06-03)	1-7,9	INV. A62C13/76
A	* figures 1,5 *	8,10,11	
A	----- GB 2 322 298 A (KIDDE THORN FIRE PROTECTION LI [GB]) 26 August 1998 (1998-08-26) * page 1 - page 2; figures *	1-11	
A	----- GB 1 566 815 A (GLOVER & CO LTD T) 8 May 1980 (1980-05-08) * page 1, line 24 - line 48; figures *	1-11	
			TECHNICAL FIELDS SEARCHED (IPC)
			A62C
The present search report has been drawn up for all claims			
Place of search		Date of completion of the search	Examiner
The Hague		4 October 2018	Vervenne, Koen
CATEGORY OF CITED DOCUMENTS			
X : particularly relevant if taken alone		T : theory or principle underlying the invention	
Y : particularly relevant if combined with another document of the same category		E : earlier patent document, but published on, or after the filing date	
A : technological background		D : document cited in the application	
O : non-written disclosure		L : document cited for other reasons	
P : intermediate document		& : member of the same patent family, corresponding document	

EPO FORM 1503 03/82 (P04C01)

**ANNEX TO THE EUROPEAN SEARCH REPORT
ON EUROPEAN PATENT APPLICATION NO.**

EP 18 18 8594

5 This annex lists the patent family members relating to the patent documents cited in the above-mentioned European search report.
The members are as contained in the European Patent Office EDP file on
The European Patent Office is in no way liable for these particulars which are merely given for the purpose of information.

04-10-2018

Patent document cited in search report	Publication date	Patent family member(s)	Publication date
JP S5059894 U	03-06-1975	JP S5059894 U JP S5223919 Y2	03-06-1975 31-05-1977
-----	-----	-----	-----
GB 2322298 A	26-08-1998	NONE	
-----	-----	-----	-----
GB 1566815 A	08-05-1980	NONE	
-----	-----	-----	-----

EPO FORM P0459

For more details about this annex : see Official Journal of the European Patent Office, No. 12/82

REFERENCES CITED IN THE DESCRIPTION

This list of references cited by the applicant is for the reader's convenience only. It does not form part of the European patent document. Even though great care has been taken in compiling the references, errors or omissions cannot be excluded and the EPO disclaims all liability in this regard.

Patent documents cited in the description

- US 3844356 A [0002]
- US 3666016 A [0003]