



AU9514190

(12) PATENT ABRIDGMENT (11) Document No. AU-B-14190/95
(19) AUSTRALIAN PATENT OFFICE (10) Acceptance No. 680334

- (54) Title
NETWORK ELEMENT IN A MOBILE COMMUNICATION SYSTEM AND A METHOD FOR PACKET DATA TRANSMISSION IN A MOBILE COMMUNICATION SYSTEM
- International Patent Classification(s)
(51)⁶ **H04L 012/56 H04Q 007/22**
- (21) Application No. : **14190/95** (22) Application Date : **20.01.95**
- (87) PCT Publication Number : **WO95/20283**
- (30) Priority Data
- (31) Number (32) Date (33) Country
940314 21.01.94 FI FINLAND
- (43) Publication Date : **08.08.95**
- (44) Publication Date of Accepted Application : **24.07.97**
- (71) Applicant(s)
NOKIA TELECOMMUNICATIONS OY; NOKIA MOBILE PHONES LTD.
- (72) Inventor(s)
JARI HAMALAINEN; JUSSI RAJALA; MATTI KESKINEN
- (74) Attorney or Agent
SPRUSON & FERGUSON , GPO Box 3898, SYDNEY NSW 2001
- (57) Claim

1. A method for packet data transmission between fixed network elements, such as a mobile exchange, a base station controller and base stations, in a mobile communication system, characterized by producing a transmission frame in accordance with a signalling protocol between the network elements and provided with an identifier for the packet data transmission,

inserting the packet data to be transmitted into the transmission frame,

transmitting the transmission frame containing packet data from a transmitting network element to a receiving network element by utilizing a connectionless signalling system between the network elements and said signalling protocol.



IN

AU9514190

<p>(51) International Patent Classification ⁶ : H04L 12/56, H04Q 7/22</p>	<p>A1</p>	<p>(11) International Publication Number: WO 95/20283 (43) International Publication Date: 27 July 1995 (27.07.95)</p>
--	------------------	---

<p>(21) International Application Number: PCT/FI95/00024 (22) International Filing Date: 20 January 1995 (20.01.95) (30) Priority Data: 940314 21 January 1994 (21.01.94) FI (71) Applicants (for all designated States except US): NOKIA TELECOMMUNICATIONS OY [FI/FI]; Mäkkylän puistotie 1, FIN-02600 Espoo (FI). NOKIA MOBILE PHONES LTD [FI/FI]; Nakolankatu 8, FIN-24100 Salo (FI). (72) Inventors; and (75) Inventors/Applicants (for US only): HÄMÄLÄINEN, Jari [FI/FI]; Matti Tapion katu 1 F 17, FIN-33720 Tampere (FI). RAJALA, Jussi [FI/FI]; Huhtakoukku 31 C, FIN-02340 Espoo (FI). KESKINEN, Matti [FI/FI]; Virtakatu 4-6 B 6, FIN-04400 Järvenpää (FI). (74) Agent: OY KOLSTER AB; Iso Roobertinkatu 23, P.O. Box 148, FIN-00121 Helsinki (FI).</p>	<p>(81) Designated States: AU, CN, DE, GB, JP, US, European patent (AT, BE, CH, DE, DK, ES, FR, GB, GR, IE, IT, LU, MC, NL, PT, SE). Published With international search report. Before the expiration of the time limit for amending the claims and to be republished in the event of the receipt of amendments. In English translation (filed in Finnish).</p> <p style="font-size: 2em; text-align: center;">680334</p>
--	--

(54) Title: NETWORK ELEMENT IN A MOBILE COMMUNICATION SYSTEM AND A METHOD FOR PACKET DATA TRANSMISSION IN A MOBILE COMMUNICATION SYSTEM

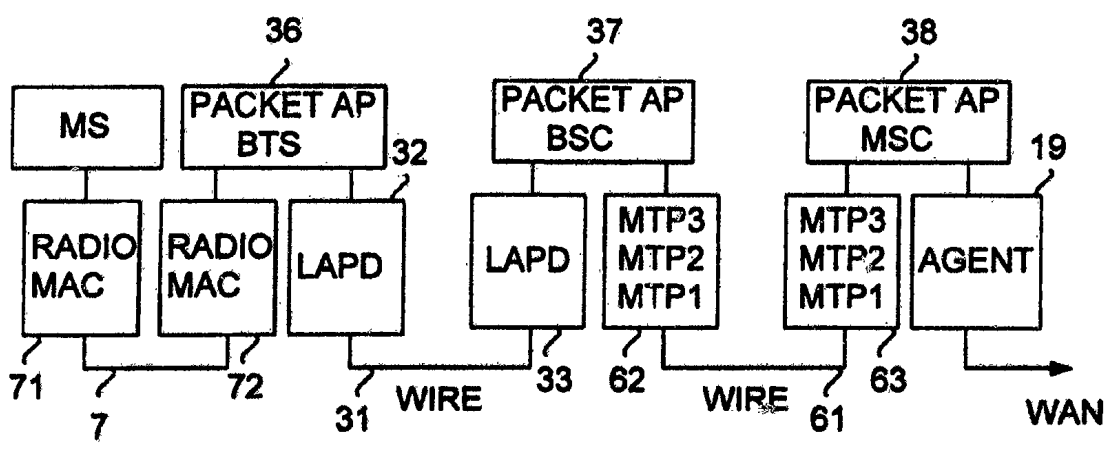

(57) Abstract

The invention relates to a method for packet data transmission between fixed network elements, such as a mobile exchange (MSC), a base station controller (BSC) and base stations (BTS), in a mobile communication system, and to fixed network elements of a mobile communication system applying such a method. A node-to-node packet data transmission in a digital mobile communication network is carried out by using network elements as packet nodes and by utilizing existing signalling protocols (LAPD, MTP) between them for transmitting data packets. Only a processing (36, 37, 64) of incoming and outgoing data packets is introduced into the network elements. The normal signalling messages of a mobile communication network used for packet data transmission are only provided with a new identifier indicating that the message contains packet data, so that the packet data messages can be forwarded to said packet data processing, instead of normal signalling message handling.

Network element in a mobile communication system and a method for packet data transmission in a mobile communication system

5 Field of the Invention

 The invention relates to a method for packet data transmission between fixed network elements, such as a mobile exchange, a base station controller and base stations, in a mobile communication system. The invention also relates to fixed network elements of a mobile communication system applying such a method.

10 Background of the Invention

 The introduction of digital mobile communication systems, such as the paneuropean mobile telephone system GSM, signifies a breakthrough, when the intention is to support mobile data transmission in public cellular networks. Since the GSM is entirely digital and utilizes general principles of an ISDN (Integrated Services Data Network), the GSM is inherently capable of transmitting data. For the user, the GSM does not represent a dedicated data transmission network, but an Access Network. In other words, data transmission via GSM is intended to allow an access into dedicated data networks. The current GSM recommendations specify only circuit switched data services in a cellular network. This means that a circuit switched connection is reserved for a data transmission in a mobile communication network and radio resources are kept allocated during the entire data session, even during silent periods when no communication whatsoever occurs. Because one characteristic feature of data communication is that data is sent in bursts, a circuit switched transfer is expensive for the user and wastes channel capacity in the network infrastructure. There is thus a need for connectionless

(not circuit switched) packet data services in the GSM network infrastructure.

5 The architecture of a conventional packet data network can be considered as a single virtual network consisting of a plurality of small interconnected networks. Each terminal equipment, e.g. a computer, is connected to one of these local networks, i.e. packet nodes, capable of transmitting data packets via other nodes to a recipient. Each data packet is routed separately, i.e. the node computer searches for the address of the recipient in a packet header and forwards the data packet to the next node by using an internal routing algorithm.

10 There are various dedicated packet switched radio networks. It is, however, difficult to apply solutions used in such networks to already standardized and even setup GSM networks without making significant modifications in the standard operation and configuration of the network and without significant economical investments. No effective solutions to provide a connectionless packet switched data transfer in a fixed network of the GSM system or a corresponding mobile communication system have been presented.

Disclosure of the Invention

25 An object of the present invention is a method for implementing a connectionless node-to-node packet data transmission between network elements in a fixed network of the GSM system or a corresponding digital mobile communication system without significant deviations from the standard configuration and operation of the network and with as low economical investments as possible.

30 This is achieved by means of a method for packet data transmission between network elements, such as a mobile exchange, a base station controller and base

35

stations, in a fixed network of a mobile communication system, which method is according to the invention characterized by

5 producing a transmission frame in accordance with a signalling protocol between the network elements and provided with an identifier for the packet data transmission,

inserting the packet data to be transmitted into the transmission frame,

10 transmitting the transmission frame containing packet data from a transmitting network element to a receiving network element by utilizing a connectionless signalling system between the network elements and said signalling protocol.

15 A second aspect of the invention is a fixed network element, such as a mobile exchange, a base station controller or a base station, in a mobile communication system, comprising signalling means for connectionless signalling in accordance with a predetermined signalling protocol with other network elements of the mobile communication network. According to the invention, the network element is characterized in that it further comprises

20 means for producing a transmission frame in accordance with said signalling protocol, which frame is provided with an identifier for the packet data transmission,

means for inserting the user packet data to be transmitted into the frame, and that

30 said signalling means transfer the transmission frame containing the packet data to another network element by using the connectionless signalling system between the network elements and said signalling protocol.

35 The present invention is based on a utilization of signalling protocols and systems existing in mobile

communication networks for packet switched data transmission between fixed network elements in mobile communication systems. In a GSM network, for instance, signalling is carried out by using CCITT Signalling System no. 7 protocols at the A interface. These protocols (hereafter called SS7) operate exactly on a node-to-node principle, i.e. provide a transmission of messages from node to node. Additionally, a similar connectionless LAPD (Link Access Protocol for the D Channel) is used at the Abis interface comprising no SS7 signalling links. Consequently, it is possible according to the invention to build a node-to-node packet data transmission in a digital mobile communication network by using network elements as packet nodes and by using signalling protocols and systems between them, such as SS7 and LAPD, for the transmission of data packets. Only means for processing incoming and outgoing data packets are introduced into the network elements. Normal signalling messages of the mobile communication network are used for packet data transmission, which messages are only provided with a new identifier indicating that the message contains packet data, so that packet data messages can be forwarded to the packet data processing means, instead of normal processing of signalling messages.

By means of the invention, a connectionless (not circuit switched) packet data transmission is provided in a fixed network of a mobile communication system without the necessity of changing the normal operation and configuration of the network hardly at all and thus without high investment costs. A connectionless packet data transmission enables an improved utilization of the channel capacity of the network and, on the other hand, a transmission method which is more advantageous for the user. Thanks to the invention, charging for a

data transmission may be based on the number of data packets transmitted. For this reason, invoicing is easy to arrange. One of the nodes along the data path examines the source address and the packet length and transmits the information to an invoicing centre.

5

Brief Description of the Drawings

The invention will be explained in the following by means of preferred embodiments with reference to the attached drawing, in which

10

Figure 1 illustrates a mobile communication network according to the invention and the interface to data networks,

Figure 2 shows an LAPD frame used at the Abis interface,

15

Figure 3 shows multiplexing of several Application Part protocols into an LAPD link at the Abis interface,

Figure 4 shows a layer 3 frame at the Abis interface,

20

Figures 5A and 5B show the basic format of an MTP message signal unit,

Figure 6 shows multiplexing of several Application Part protocols into an MTP link at the A interface,

Figure 7 shows a protocol stack of a node-to-node connection,

25

Figure 8 shows a data packet format used between a base station controller and a packet processing computer, and

Figure 9 shows a data packet format used between a base station and a base station controller.

30

Preferred Embodiments of the Invention

The present invention is suitable for being used in all mobile communication systems using a connectionless CCITT Signalling System no. 7 (SS7) signalling protocol or the like. The invention is particularly pre-

35

ferable for being used in the paneuropean digital mobile communication system GSM and in corresponding digital systems, such as DCS1800 and PCN. The preferred embodiments of the invention will be described below implemented in the GSM system, but not restricted to that, however.

As regards the detailed configuration and operation of the GSM system, reference is made to the ETSI recommendations concerning GSM as well as to the book "The GSM System for Mobile Communications", M. Mouly & M. Pautet, Palaiseau, France, ISBN:2-9507190-0-7.

Figure 1 shows schematically part of a GSM cellular radio system. The area covered by a cellular radio system is subdivided into radio cells. Base station systems BSS (only 2 of them shown in the figure) are connected by digital transmission links 9 to a mobile exchange MSC 10. Each base station system BSS comprises a base station controller BSC, to which is further connected one base station or several base stations BTS by digital transmission links 8. The radio coverage area of one base station BTS typically constitutes one radio cell. A predetermined number of RF carrier frequencies is allocated to each base station BTS1 to BTS4. A signal of the GSM system consists of TDMA frames, each of them containing preferably 8 time slots, by which logical channels are transferred. The logical channels contain traffic channels for establishing calls (speech and data) with mobile radio stations MS3 within the cell, and control channels for signalling with the mobile radio stations MS3 (mobile stations) within the cell. A speech connection, a V.110 rate adapted 64 kbit/s Full Duplex data connection or a 9,6/4,8/2,4 kbit/s data connection can be established on the traffic channels. A traffic channel can also be configured to

a 12 kbit/s data channel, if transmission protocol RLP (Radio Link Protocol) is not used.

5 In the GSM network, data transmission is at present arranged on a circuit switched channel dedicated for each mobile station MS3 as per need. In other words, a traffic channel in a radio path 7 and a transmission channel in the digital transmission links 8 and 9 are allocated for each circuit switched data transmission channel for the entire data session. A special-purpose
10 connection adapter for adapting a data connection to terminal equipments and/or other transmission connections/transmission systems is typically needed at both ends of the data connection. A connection adapter associated with a mobile station MS3 is generally called
15 terminal adapter and a connection adapter at the network end is called interworking function IWF. In general, such an interworking function is located in the mobile exchange MSC of the GSM mobile communication network.

In the GSM recommendations, three different
20 interfaces can be distinguished, i.e. radio interface over the radio path 7, Abis interface between a base station BTS and a base station controller BSC and A interface between a base station controller BSC and a mobile exchange MSC. The A interface is also applied to
25 digital connections 11 between two mobile exchanges MSC. Signalling at the A interface of the GSM network is carried out by the CCITT Signalling System no. 7 protocol. This protocol proceeds on a node-to-node principle, i.e. provides a data transmission in node-to-node messages.
30 The LAPD (Link Access Protocol for the D Channel) is used at the Abis interface.

In accordance with the invention, it is possible to construct in the fixed part of a mobile communication network a node-to-node packet transmission in the
35 same way as in packet data networks, by implementing the

network elements, such as the base stations BTS, the base station controllers BSC and the mobile exchanges MSC, as packet nodes and by using signalling links between them, such as SS7 and LAPD links, for the transmission of the data packets.

5 By means of the invention, a mobile station MS3, consisting according to Figure 1 for instance of a mobile radio station 3 and a remote work station 4 (e.g. a personal computer PC) connected thereto, may send a data packet to a base station BTS4 by a new access method, which is suitable for packet data transmission and uses a radio channel only during the time needed for the transmission of the data packet. The invention is independent of which access method is used at the radio interface 7 between the mobile station MS3 and the base station BTS, since the invention relates primarily to implementing a packet transmission between fixed network elements. The base station BTS4 transmits the data packet received from the mobile station MS3 to a base station controller BSC, which forwards the data packet to a mobile exchange MSC. The data packet is routed in every node based on a destination address in a packet header, and each packet is routed independently.

25 In the preferred embodiment of the invention shown in Figure 1, a computer 19, referred to as AGENT19 below, is additionally associated with the mobile exchange MSC for processing data packets. The AGENT19 is a data service centre, to which all data packets from the mobile stations MS3 located within its service area are routed. The AGENT19 also attends to location updating of the mobile stations MS3 using data services, as will be explained in more detail below. Addressing and routing of the data packets between the base station controller BSC, the mobile exchange MSC and the AGENT19

are carried out by standard SS7 procedures on MTP3 (Message Transfer Part) level. In the preferred embodiment of the invention, routing from the base station controller BSC to the mobile station MS3 is based on the identity of the mobile station MS, as will be explained below. As already noted above, the routing of the data packets from the mobile station MS is rather straightforward, since the data packets are always routed to the service centre AGENT19 serving the area.

The data service centre AGENT19 is in the preferred embodiment of the invention shown in Figure 1 connected by a conventional router 18 to external data networks, such as WAN (Wide Area Network). The service centre AGENT19 thus constitutes an interface between the MSC10 and the external data networks WAN. The interface between the mobile exchange MSC10 and the service centre AGENT19 connected thereto as well as the used protocol are not essential for the invention and will usually be dependent on the manufacturer of the mobile exchange MSC. In the preferred embodiment of the invention, however, a direct data link between the MSC10 and the data service centre AGENT19, allocated for this purpose, and a manufacturer-specific protocol are used. One alternative solution is that the data service centre 19 is a switching node similar to, for instance, the mobile exchange MSC or the base station controller BSC, in the SS7 signalling network.

It is also possible to connect any of the nodes, i.e. network elements, of the mobile communication network to an external network, such as WAN. This is effected by connecting a data service centre (similar to AGENT19, for instance) to the node via which the gateway to the external network is provided. The AGENT19 could thus be connected alternatively to the base station controller BSC or even to the base station BTS.

It is assumed in the preferred embodiment of the invention that a data service centre AGENT is connected to each mobile exchange MSC. However, if the network operator wishes to use only one data service centre AGENT in the whole network, which is connected to one of the mobile exchanges, a particular centralizing routing function must be used between the mobile exchanges. The protocol used at the interface between two mobile exchanges MSC is the MTP, i.e. the same protocol as is used at the interface between the mobile exchange MSC and the base station controller BSC. The routing of data packets from one mobile exchange MSC towards a centralized data service centre AGENT connected to another mobile exchange MSC is thus performed on the same principle as the routing from the base station controller BSC to the mobile exchange MSC. The addressing used for routing is based on destination point code, each mobile exchange MSC and data service centre AGENT having a unique point code in the mobile communication network for identifying the network element in question. The mobile exchange MSC (relay MSC) transmitting the data packet comprises a packet processing unit attending to the procedures needed for forwarding the data packets.

In the following, the protocols used in the preferred embodiment shown in Figure 1 at different interfaces, i.e. radio interface 7 (MS-BTS interface), BTS-BSC interface 8 and BSC-MSC interface 9, will be examined in more detail.

Radio interface

As mentioned above, the present invention is independent of the access method used for packet transmission at the radio interface 7. To clarify the concept, however, an example of such a media access control is given. It is assumed in all protocols that the media

access control is carried out between a mobile station MS and a base station BTS, whereby no involvement of the other network elements, i.e. nodes, is needed.

5 It is possible to allocate several traffic channels or even a carrier solely for packet data transmission. In this case, uplink and downlink channels could be used. Packet data transmitted by a mobile station on an uplink channel could optionally be forwarded immediately to a downlink channel. This could secure the
10 mobile station MS of the correctness of the data packet transmitted. The access method could be any Aloha-based media access control method. All mobile stations try to get an access to a traffic channel. This mechanism might require some modifications of the lower layers of the
15 GSM system, but it may also be provided by means of a standard traffic channel structure, due to which only a new media access control needs be implemented.

BTS-BSC interface procedures

20 The signalling link protocol over the Abis interface is the LAPD, which is a HDLC (High Level Data Link Control) type link protocol. In addition to the properties from the HDLC protocol, the LAPD includes a management of many simultaneous connections. The LAPD provides a reliable transfer over a direct link between two nodes.
25

Figure 2 shows the format of an LAPD frame. The length of the LAPD frames of the Abis interface is limited to 264 octets, comprising 260 octets for upper layer information. Flow control numbering is based on
30 modulo 128 and the information flow is continuous. Thus no data rate limitation is detected. Services are divided into connection-oriented and connectionless services. Connectionless service is used mainly for transmitting management information. For the invention, connectionless protocol is the most interesting one, since
35

it fits perfectly to connectionless packet data transmission. This requires only a small additional definition for the LAPD frame. Currently, transceivers TRX and other units of the base station BTS may have either one
5 common physical connection to the base station controller BSC or each transceiver may have a physical connection of its own. The addressing of signalling packets to a transceiver TRX and other units of a base station is made by using a Terminal Endpoint Identifier (TEI)
10 field of the LAPD frame. Then each transceiver and other unit has its own TEI. Different logical links may be defined for a TEI value by means of a Service Access Point Identifier (SAPI) field of the LAPD frame. At present, three logical links are defined for each TEI value:

- 15 - Radio Signalling Link (RSL) for supporting traffic management procedures, SAPI = 0
- Short Message Service, SAPI = 3
- Operations and Maintenance Link (OML) for supporting network management procedures, SAPI = 62
- 20 - Layer 2 Management Link (L2ML) for layer 2 management messages, SAPI = 63.

For a packet data transmission according to the invention, a new logical link and a new corresponding SAPI value are reserved:

- 25 - Packet Data Link (PDL) for packet data transmission procedures, SAPI = x (e.g. SAPI = 5).

Furthermore, it is possible that there exists a separate physical packet data connection (or even several connections) for each base station transceiver TRX
30 having packet channels at the radio interface 7. Another possibility is that there exists a common physical connection to the radio signalling link RSL and the packet data link PDL, if the amount of packet data traffic is low. The use of different SAPI values makes it possible
35 to give different priorities to the radio signalling

link RSL and the packet data link PDL when a common physical connection is used.

Figure 3 shows multiplexing of different Appli-
cation Part (AP) protocols into an LAPD link of the Abis
interface. Figure 3 shows a base station BTS and a base
station controller BSC, which are interconnected by a
physical connection 31. The base station BTS is provided
with means 32 and the base station controller BSC with
means 33, respectively, for establishing an LAPD proto-
col LAPD link between the base station BTS and the base
station controller BSC over the physical connection 31.
For the invention, the base station BTS and the base
station controller BSC comprise packet processing means
36 and 37, respectively, i.e. a packet application part
(packet AP), taking the packet processing measures re-
quired by a packet transmission according to the inven-
tion. Other application parts AP, such as signalling,
using LAPD protocol transmission, are generally indi-
cated by blocks 34 and 35. These blocks are of no sig-
nificance for the invention and they are not discussed
in further detail herein. In the transmission direction,
the packet processing means 36 or 37 insert the data
packet to be sent in an information field of an LAPD
frame, as shown in Figure 5A, and insert in a SAPI field
an identifier indicating the packet data transmission.
The constructed LAPD protocol frame is applied to the
LAPD means 32 or 33 of a transmitting network element,
i.e. a node, in order to further forward the LAPD frame
in accordance with the LAPD protocol to the LAPD means
32 or 33 of a receiving network element, i.e. a node.
In the uplink direction the BSC forwards the packet to
the MSC/service centre AGENT19.

In the downlink direction, the packet process-
ing means 37 of the BSC select the traffic channel on
which the packet is transmitted from the base station

BTS to the mobile station MS. It is assumed in a preferred embodiment of the invention that the mobile stations MS are divided into groups, each of them using always the same physical packet data channel in a cell.

5 To reduce the power consumption of the mobile station MS, this channel may be further divided into blocks, each MS monitoring one of the blocks to monitor the data packets sent by the base station BTS. The channel and the block within the channel are determined by a Mobile

10 Station Identity IMSI. The base station controller BSC sends the channel number and the group number to the base station BTS in a layer 3 message of the Abis interface, which message is depicted in Figure 4. This frame contains in the data part a higher level data packet,

15 the transmission of which is going on between the mobile station MS and the MSC/AGENT19. This data packet may be e.g. of the type shown in Figures 8 and 9, in which case is also contains the header part thereof. The header field of the Abis interface frame in Figure 4 depends

20 on the Media Access Control method used on the radio interface. If the channel is not divided into subgroups, there is no need for the group number field in the header field. Message type field may also be omitted, if only one kind of messages are transmitted.

25 BSC-MSC interface procedures

The SS7 protocols used for common channel signalling at the A interface are Message Transfer Part (MTP) and Signalling Connection Control Part (SCCP). These protocols can be used for connectionless packet

30 data transmission on node-to-node principle. In the preferred embodiment of the invention, the packet data transmission is implemented on the MTP level.

The MTP is a lower protocol taking care of a physical data link, a signalling data link and signalling network functions (signalling message handling and

35

signalling network management). The MTP is defined in CCITT red book recommendations Q.702 to Q.704 and Q.707. The transmission is carried out at the data rate of 64 kbit/s over a physical link (MTP1). Signalling link functions (MTP2) take care of the functions and procedures relating to the transfer of messages over an individual link; including delimitation of signal units, error correction and sequence control. Thus the data transmitted over the link should be free of errors. The MTP 3 provides the signalling network management functions and the signalling message handling functions. The actual transfer of messages is carried out by the MTP level 3. The level 3 of the MTP has three main functions: discrimination of messages belonging to a local user part, routing of messages and distribution of messages to the appropriate user parts. A Message Signal Unit (MSU) has a variable length, 272 octets at the A interface at the maximum, including 8 octets for the header. The services produced by the MTP for higher levels are MTP-TRANSFER, MTP-PAUSE and MTP-RESUME.

The structure of an MTP signal unit is depicted in Figures 5A and 5B. The most important fields are a length indicator (length of a signalling information field in a signalling unit), a service information octet (used for indicating a particular user part) and a signalling information field (carrying actual higher level signalling information). The signalling information field consists of a routing label and higher level data. The routing label is used for routing message signal units. The routing is based on a destination point code, which is unique throughout the whole national telecommunication area. The MTP based message transfer is a connectionless service of datagram type, i.e. each message signal unit is routed independently of each other.

The node-to-node packet transmission system according to the invention is built on top of an MTP protocol stack. This enables the equal packet size to be used at the Abis and A interfaces. Additionally, the amount of header information is minimized, since no SCCP is used. However, the implementation is not restricted to the MTP, but it is also possible to build a packet transmission system according to the invention on top of the SCCP, as will be explained later. Functions on the MTP level 3 are used for packet transfer according to the invention between a mobile exchange MSC and a base station controller BSC. A new value is determined in a Service Information Octet (SIO) field of the MTP message signal unit according to Figure 5A as an identifier for the packet data transmission, by means of which identifier the packet data frames can be distinguished from the other MTP frames.

Figure 6 shows a base station controller BSC and a mobile exchange MSC, which are interconnected by a physical connection 61. The base station controller BSC and the mobile exchange MSC comprise means 62 and 63, respectively, for carrying out an MTP protocol message transfer over the physical connection 61. For the invention, the base station controller BSC and the mobile exchange MSC comprise packet processing means 37 and 64, respectively, i.e. a packet application part (packet AP), carrying out the packet processing required by the packet transmission according to the invention. Other application parts AP, such as signalling, using MTP protocol transmission, are generally indicated by blocks 35 and 65. These blocks are of no significance for the invention and are not discussed in further detail in this connection. In the transmission direction, the packet processing means 37 or 64 insert the data packet to be transmitted in a Signalling Information

Field (SIF) of an MTP frame according to Figure 5A, and insert in the SIO field an identifier for the packet data transfer. The constructed MTP protocol frame is applied to the MTP means 62 or 63 of a transmitting network element, i.e. a node, which forwards the frame, in accordance with the MTP protocol, to the MTP means 62 or 63 of a receiving network element, i.e. a node. The MTP means 62 or 63 of the receiving node analyze the SIO field of the received MTP frame and forward the packets, in which the SIO contains the packet data transfer identifier, to the packet data processing means 37 or 64 of the network element. The packet data processing means 37 or 64 examine the SIF field of the frame and extract the data packet for further processing. In the uplink direction the MSC transmits the packet to the data service centre AGENT19 or another mobile exchange MSC. In the downlink direction the BSC transmits the data to the base station in the manner described above.

Packet data transmission according to the invention at the A interface can be carried out by using the Signalling and Connection Control Part (SCCP) protocol instead of the MTP protocol. The SCCP uses services produced by the MTP. The SCCP is defined in CCITT red book recommendations Q.711 to Q.714. The SCCP produces for the MTP additional functions covering connectionless and connection-oriented network services. The most interesting alternative is to use connectionless service for packet transmission. There exist two classes of connectionless services: class 0 and class 1. Class 0 does not include sequence control information, but class 1 does. The sequence control information enables a reception of a plurality of packets in transmission order. However, only class 0 is in use in the GSM system. The length of one connectionless NSDU is 32 octets. This alternative enables a use of a signalling link only when

required, and a multiplexing of several connections into the same link could be arranged easily. It is possible to carry out the packet data transmission described above in connection with the MTP protocol by using a SCCP layer on top of the MTP. The packet format is, however, smaller and requires an implementation of fragmentation functions.

A node-to-node connection in a packet data transmission according to the invention can be described on system level by means of a protocol stack according to Figure 7. Between a mobile station MS and a packet handler 36 of a base station BTS, there are means 71 and 72 performing a media access control of the radio path 7. Between the packet handler 36 of the base station BTS and the packet handler 37 of the base station controller, there is an LAPD protocol connection, as described in connection with Figure 3. Correspondingly, between the packet handler 37 of the base station controller BSC and the packet handler 64 of a mobile exchange MSC, there are means 62 and 63 implementing the MTP protocol, as explained in connection with Figure 6. On the other hand, the packet handler 64 of the mobile exchange MSC communicates with a packet service centre AGENT19, which again forwards the packets to an external data network WAN. One function of the packet handler of the base station BTS is to adapt the packet data to be transmitted in an LAPD protocol transmission frame to the media access control method MAC used between the base station and the mobile station, and to the packet data transmission protocol. Correspondingly, one task of the packet data handler of the base station controller BSC is to adapt the packet data to be transferred in LAPD protocol transmission frames between the base station and the base station controller to MTP signalling protocol

transmission frames used between the base station and the mobile exchange and vice versa.

5 The packet format used between the base station controller BSC and the data service centre AGENT19 connected to the mobile exchange MSC is shown in Figure 8. The packet contains a Cell Identifier ID, a Mobile Station Identifier MS ID, control data Control and a user data block Data.

10 At the Abis and radio interfaces, the packet format is reduced from the format shown in Figure 7. The base station controller BSC uses the cell identification field Cell ID for transmitting the packet to the correct base station BTS. The Cell ID field is eliminated in the base station controller BSC in order to reduce the amount of extra header information to be transmitted
15 over the radio path.

In this way, the packet format will be as shown in Figure 9. In a packet transmission starting from a mobile station MS, the mobile station MS transmits the packet shown in Figure 9 over the radio path and a base station BTS transmits it to a base station controller BSC. In the base station controller BSC, a packet processing means 37 adds the Cell ID field to the packet.
20

25 The figures and the description relating to them are only intended to illustrate the present invention. As regards the details, the invention may vary within the scope and spirit of the attached claims.

Claims:

- 5
10
15
20
25
30
35
1. A method for packet data transmission between fixed network elements, such as a mobile exchange, a base station controller and base stations, in a mobile communication system, characterized by producing a transmission frame in accordance with a signalling protocol between the network elements and provided with an identifier for the packet data transmission,
inserting the packet data to be transmitted into the transmission frame,
transmitting the transmission frame containing packet data from a transmitting network element to a receiving network element by utilizing a connectionless signalling system between the network elements and said signalling protocol.
 2. A method according to claim 1, characterized by receiving the transmission frame in accordance with the signalling protocol by a network element, analyzing whether the transmission frame is a signalling frame or a transmission frame used for packet data transmission and containing the packet data transmission identifier,
forwarding the transmission frame containing the packet data transmission identifier to data packet processing.
 3. A method according to claim 1 or 2, characterized in that the packet data transmission between a base station and a base station controller comprises the steps of producing an LAPD transmission frame, in which a Service Access Point Identifier field is provided with the packet data transmission identifier,

inserting the packet data to be transmitted into the LAPD transmission frame,

transmitting the transmission frame containing packet data to the network element indicated by a destination address by using a connectionless LAPD signalling system between the network elements and the LAPD signalling protocol.

5

4. A method according to claim 1, 2 or 3, characterized in that the packet data transmission between a base station controller and a mobile exchange as well as between mobile exchanges, respectively, comprises steps of

10

producing an MTP protocol transmission frame, in which a Service Identification Octet field is provided with the packet data transmission identifier,

15

inserting the packet data to be transmitted into the MTP transmission frame,

transmitting the transmission frame containing packet data to the network element indicated by a destination address by using a connectionless MTP signalling system between the network elements and the MTP signalling protocol.

20

5. A method according to claim 1, 2 or 3, characterized by utilizing an SCCP protocol in the packet data transmission between a base station controller and a mobile exchange as well as between mobile exchanges, respectively.

25

6. A fixed network element, such as a mobile exchange, a base station controller or a base station, in a mobile communication system, comprising signalling means for connectionless signalling in accordance with a predetermined signalling protocol with other network elements of the mobile communication network, characterized in that the network element further comprises

30

35

means for producing a transmission frame in accordance with said signalling protocol, which frame is provided with an identifier for the packet data transmission,

5 means for inserting the user packet data to be transmitted into the frame, and that

said signalling means transfer the transmission frame containing packet data to another network element by using the connectionless signalling system between
10 the network elements and said signalling protocol.

7. A network element according to claim 6, characterized in that the network element additionally comprises

15 means for analyzing transmission frames received from another network element

means for extracting packet data from transmission frames containing the packet data transmission identifier.

20 8. A network element according to claim 6 or 7, characterized in that the network element further comprises

means for analyzing the transmission frames received from another network element,

25 means for transmitting the transmission frames containing the packet data transmission identifier further to next network element.

30 9. A network element according to claim 6, 7 or 8, characterized in that the network element is a base station and comprises means for adapting the packet data to be transmitted in transmission frames in accordance with said signalling protocol, such as the LAPD, to a packet data transmission protocol used between the base station and a mobile station.

35 10. A network element according to any of the claims 6 to 9, characterized in that the

network element is a base station controller and comprises means for inserting the packet data from the transmission frames in accordance with a first signalling protocol, such as the LAPD, between the base station and the base station controller into transmission frames in accordance with a second signalling protocol, such as the MTP, between the base station controller and a mobile exchange and vice versa.

5

11. A network element according to any of the claims 6 to 10 characterized in that the network element is a mobile exchange and comprises packet data processing means and means for transferring transmission frames, which are in accordance with the signalling protocol and contain the packet data transmission identifier between the packet data processing means and another network element.

10

12. A network element according to claim 11, characterized in that the packet data processing means comprise a router interconnecting the mobile communication system to a data network, such as WAN.

15

13. A network element according to claim 12, characterized in that the packet data processing means are connected to a mobile exchange by a dedicated connection or a SS7 signalling network.

20

14. Method substantially as described herein with reference to the accompanying drawings.

DATED this SECOND day of AUGUST 1996

Nokia Telecommunications OY

Patent Attorneys for the Applicant

SPRUSON & FERGUSON

25



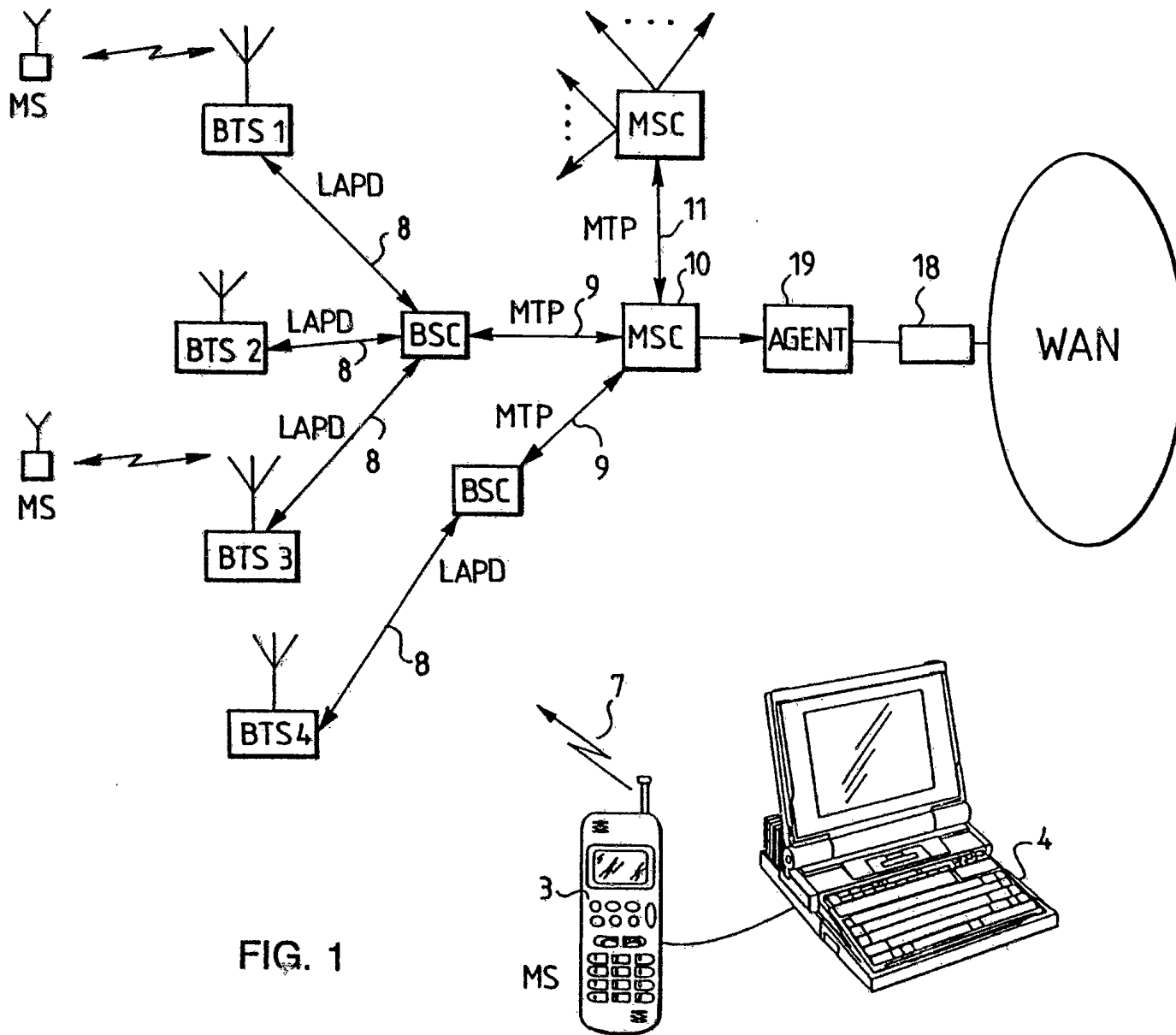
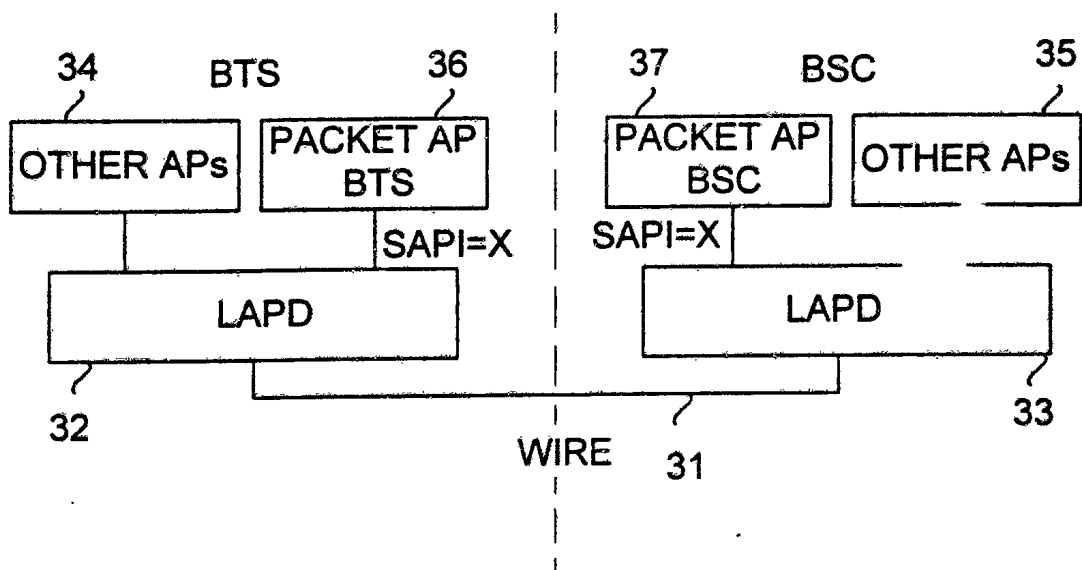
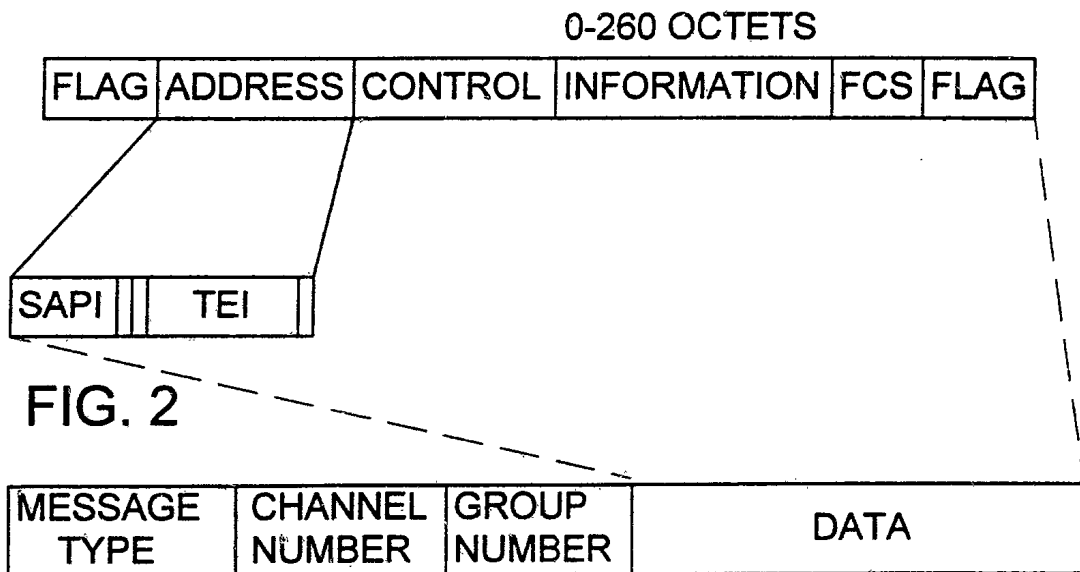
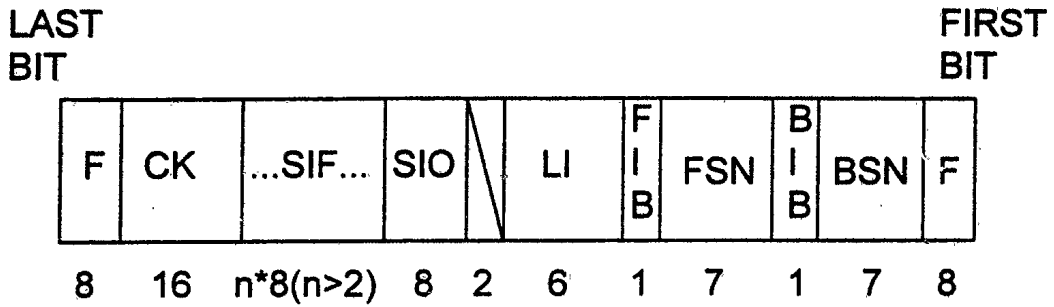

FIG. 1





CK CHECK BITS
 F FLAG
 LI LENGTH INDICATOR
 SF SPACE FIELD
 SIF SIGNALLING INFORMATION FIELD
 SIO SERVICE INFORMATION FIELD

FIG. 5A

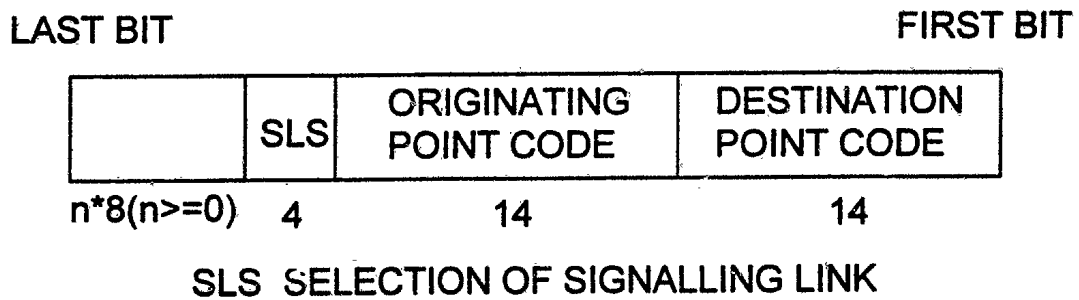

FIG. 5B

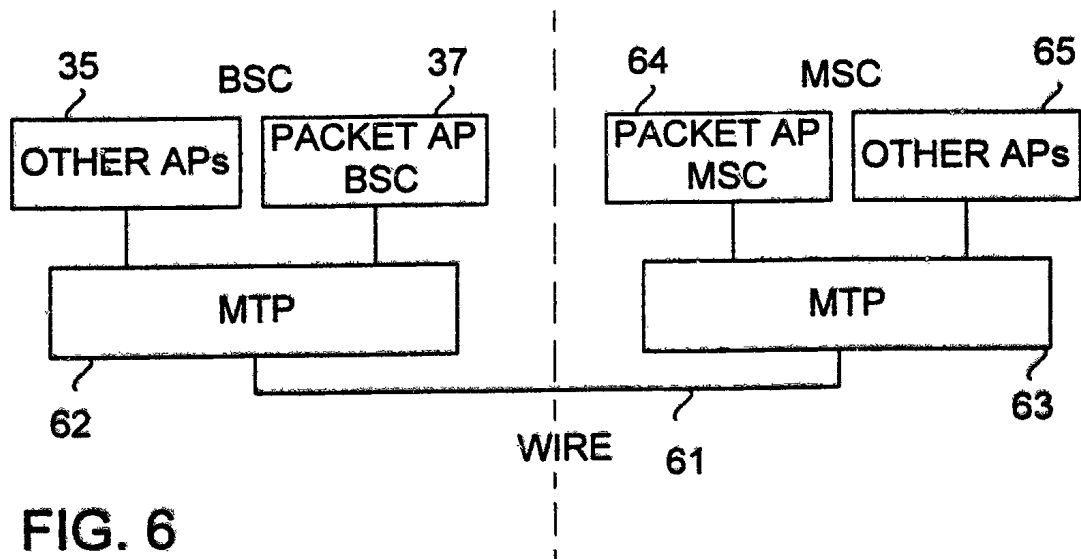

FIG. 6

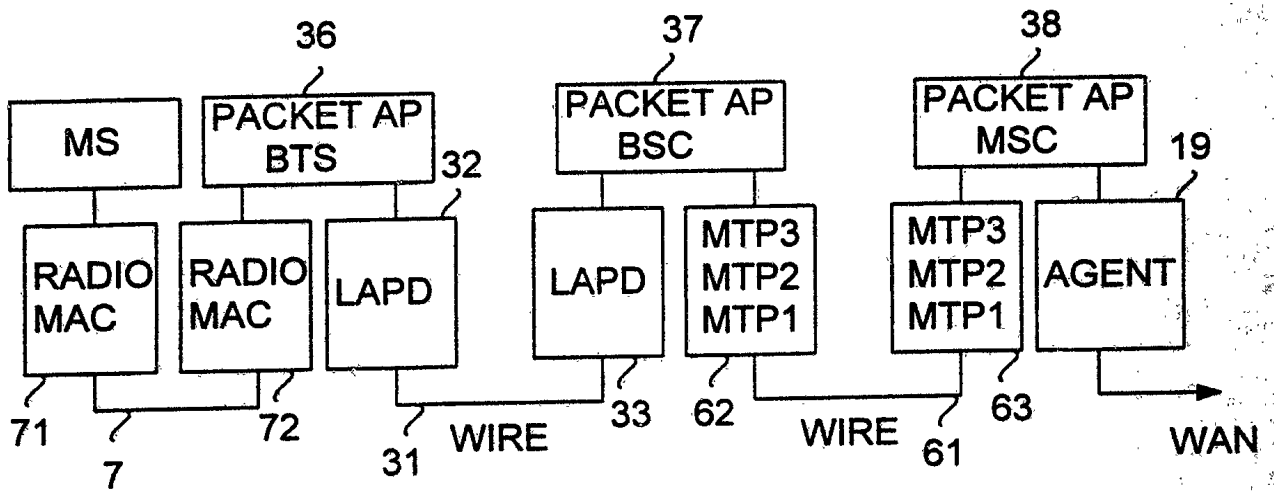

FIG. 7



FIG. 8

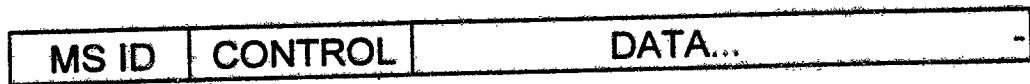

FIG. 9

INTERNATIONAL SEARCH REPORT

International application No.
PCT/FI 95/00024

A. CLASSIFICATION OF SUBJECT MATTER

IPC6: H04L 12/56, H04Q 7/22
According to International Patent Classification (IPC) or to both national classification and IPC

B. FIELDS SEARCHED

Minimum documentation searched (classification system followed by classification symbols)

IPC6: H04L, H04Q

Documentation searched other than minimum documentation to the extent that such documents are included in the fields searched
SE,DK,FI,NO classes as above

Electronic data base consulted during the international search (name of data base and, where practicable, search terms used)

DIALOG: WPI, CLAIMS

C. DOCUMENTS CONSIDERED TO BE RELEVANT

Category*	Citation of document, with indication, where appropriate, of the relevant passages	Relevant to claim No.
X	EP, A2, 0522773 (AMERICAN TELEPHONE AND TELEGRAPH COMPANY), 13 January 1993 (13.01.93), column 14, line 21 - column 15, line 33, figures 7-10 --	1-13
A	TDOC SMGL 238/93, J. Hämäläinen et al: "Packet data over GSM network", 28.09.1993, p. 1-8 see page 4, line 1-23 --	1-13
A	US, A, 5168498 (JOHN L. ADAMS ET AL), 1 December 1992 (01.12.92), column 1, line 52 - column 2, line 5; column 2, line 63 - column 3, line 45, figure 3 -- -----	1-13

Further documents are listed in the continuation of Box C. See patent family annex.

- | | |
|---|--|
| <ul style="list-style-type: none"> * Special categories of cited documents: * "A" document defining the general state of the art which is not considered to be of particular relevance * "E" earlier document but published on or after the international filing date * "L" document which may throw doubts on priority claim(s) or which is cited to establish the publication date of another citation or other special reason (as specified) * "O" document referring to an oral disclosure, use, exhibition or other means * "P" document published prior to the international filing date but later than the priority date claimed | <ul style="list-style-type: none"> * "T" later document published after the international filing date or priority date and not in conflict with the application but cited to understand the principle or theory underlying the invention * "X" document of particular relevance: the claimed invention cannot be considered novel or cannot be considered to involve an inventive step when the document is taken alone * "Y" document of particular relevance: the claimed invention cannot be considered to involve an inventive step when the document is combined with one or more other such documents, such combination being obvious to a person skilled in the art * "&" document member of the same patent family |
|---|--|

Date of the actual completion of the international search	Date of mailing of the international search report
14 June 1995	15 -06- 1995

Name and mailing address of the ISA/ Swedish Patent Office Box 5055, S-102 42 STOCKHOLM Facsimile No. +46 8 666 02 86	Authorized officer Göran Magnusson Telephone No. +46 8 782 25 00
--	--

INTERNATIONAL SEARCH REPORT
 Information on patent family members

03/05/95

International application No.
 PCT/FI 95/00024

Patent document cited in search report	Publication date	Patent family member(s)	Publication date
EP-A2- 0522773	13/01/93	JP-A- 6253363	09/09/94
		US-A- 5278892	11/01/94
US-A- 5168498	01/12/92	AU-B- 625703	16/07/92
		AU-A- 5477790	08/11/90
		EP-A- 0426269	08/05/91
		JP-A- 3205928	09/09/91