



INTERNATIONAL APPLICATION PUBLISHED UNDER THE PATENT COOPERATION TREATY (PCT)

<p>(51) International Patent Classification ⁶ : E04B 2/06, 2/58</p>	<p>A1</p>	<p>(11) International Publication Number: WO 99/55976 (43) International Publication Date: 4 November 1999 (04.11.99)</p>
<p>(21) International Application Number: PCT/SG98/00030 (22) International Filing Date: 27 April 1998 (27.04.98) (71) Applicant (for all designated States except US): DYNTEK PTE LTD. [SG/SG]; 6 Sungei Kadut Street #2, Singapore 729228 (SG). (72) Inventors; and (75) Inventors/Applicants (for US only): NG, Wee, Beng [SG/SG]; 56 Coronation Road West #05-04, Astrid Meadows, Singapore 269269 (SG). WYATT, Gary, Donald [AU/SG]; 365 Holland Road #07-01, Allsworthy Park, Singapore 278639 (SG). (74) Agent: MCCALLUM, Graeme, David; Lloyd Wise, Tanjong Pagar, P.O. Box 636, Singapore 910816 (SG).</p>		<p>(81) Designated States: AL, AM, AT, AU, AZ, BA, BB, BG, BR, BY, CA, CH, CN, CU, CZ, DE, DK, EE, ES, FI, GB, GE, GH, GM, GW, HU, ID, IL, IS, JP, KE, KG, KP, KR, KZ, LC, LK, LR, LS, LT, LU, LV, MD, MG, MK, MN, MW, MX, NO, NZ, PL, PT, RO, RU, SD, SE, SG, SI, SK, SL, TJ, TM, TR, TT, UA, UG, US, UZ, VN, YU, ZW, ARIPO patent (GH, GM, KE, LS, MW, SD, SZ, UG, ZW), Eurasian patent (AM, AZ, BY, KG, KZ, MD, RU, TJ, TM), European patent (AT, BE, CH, CY, DE, DK, ES, FI, FR, GB, GR, IE, IT, LU, MC, NL, PT, SE), OAPI patent (BF, BJ, CF, CG, CI, CM, GA, GN, ML, MR, NE, SN, TD, TG).</p> <p>Published With international search report.</p>

(54) Title: A SUPPORT MEMBER

(57) Abstract

A support member includes an elongate member (2, 3) being a side wall (30) adapted to be located adjacent an end of a structure (1) to be supported. The side wall (30) includes a number of engagement means (22, 24) which permit a tie member (7) to be mounted on the side wall (30). The tie member (7) has a portion (23) projecting from the side wall (30) to engage with the structure (1) to be supported.

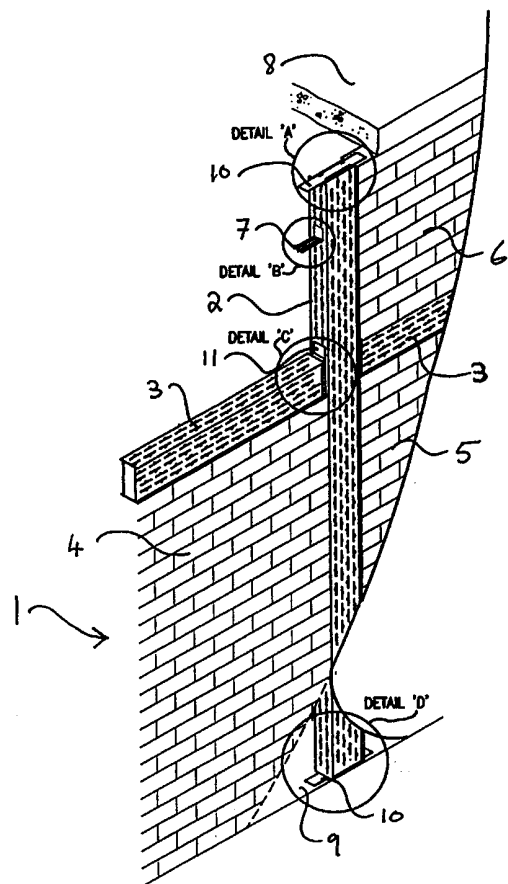

FOR THE PURPOSES OF INFORMATION ONLY

Codes used to identify States party to the PCT on the front pages of pamphlets publishing international applications under the PCT.

AL	Albania	ES	Spain	LS	Lesotho	SI	Slovenia
AM	Armenia	FI	Finland	LT	Lithuania	SK	Slovakia
AT	Austria	FR	France	LU	Luxembourg	SN	Senegal
AU	Australia	GA	Gabon	LV	Latvia	SZ	Swaziland
AZ	Azerbaijan	GB	United Kingdom	MC	Monaco	TD	Chad
BA	Bosnia and Herzegovina	GE	Georgia	MD	Republic of Moldova	TG	Togo
BB	Barbados	GH	Ghana	MG	Madagascar	TJ	Tajikistan
BE	Belgium	GN	Guinea	MK	The former Yugoslav Republic of Macedonia	TM	Turkmenistan
BF	Burkina Faso	GR	Greece	ML	Mali	TR	Turkey
BG	Bulgaria	HU	Hungary	MN	Mongolia	TT	Trinidad and Tobago
BJ	Benin	IE	Ireland	MR	Mauritania	UA	Ukraine
BR	Brazil	IL	Israel	MW	Malawi	UG	Uganda
BY	Belarus	IS	Iceland	MX	Mexico	US	United States of America
CA	Canada	IT	Italy	NE	Niger	UZ	Uzbekistan
CF	Central African Republic	JP	Japan	NL	Netherlands	VN	Viet Nam
CG	Congo	KE	Kenya	NO	Norway	YU	Yugoslavia
CH	Switzerland	KG	Kyrgyzstan	NZ	New Zealand	ZW	Zimbabwe
CI	Côte d'Ivoire	KP	Democratic People's Republic of Korea	PL	Poland		
CM	Cameroon	KR	Republic of Korea	PT	Portugal		
CN	China	KZ	Kazakstan	RO	Romania		
CU	Cuba	LC	Saint Lucia	RU	Russian Federation		
CZ	Czech Republic	LI	Liechtenstein	SD	Sudan		
DE	Germany	LK	Sri Lanka	SE	Sweden		
DK	Denmark	LR	Liberia	SG	Singapore		
EE	Estonia						

A SUPPORT MEMBER

The invention relates to a support member and in particular, a support member for, at least partially, supporting a wall.

Walls constructed from bricks have a maximum length and height to which they can be constructed without requiring additional support to prevent flexing or collapsing of the wall. Conventionally, brick walls have been supported by erecting concrete supports at intervals along the brick wall, both horizontally and vertically, to support the wall. As the brick wall requires to be mechanically tied to the concrete supports, it is conventional practice to use metal rods which are fixed to the cement work of the brick wall and to the concrete supports to tie the brick wall to the concrete supports.

However, one of the disadvantages of this conventional approach is that the construction and use of concrete supports is both time consuming and labour intensive. In order to form the concrete support it is necessary to construct shuttering to enclose the volume into which the concrete is to be poured. The shuttering is normally constructed from wooden boards and requires the services of a joiner in order to construct the shuttering. In addition, during construction of the shuttering, it is necessary to insert the metal rods, which will be used to tie the brick wall to the concrete support, through the side walls of the

shuttering so that the metal rods extend outside the shuttering and into the internal volume of the shuttering where the concrete is to be poured. This requires the services of a steel bender to bend and install the metal rods as required.

After the shuttering is complete and the metal rods have been inserted, concrete is then poured into the shuttering and permitted to harden before the shuttering is removed. When the shuttering is removed, the metal rods are bonded to the concrete and the brick wall is tied to the concrete supports by the metal rods.

Hence, the conventional method of supporting brick walls using concrete supports is time consuming, labour intensive and requires the services of three different tradesman (joiner, steel bender and concrete pourer) in addition to a brick layer to construct the wall itself.

In accordance with the present invention, a support member comprises an elongate member having a side wall adapted to be located adjacent an end of a structure to be supported, in use, the side wall including a number of engagement means which permit a tie member to be mounted on the side wall, the tie member having a portion projecting from the side wall to engage with the structure to be supported.

Preferably, the elongate member may be hollow and typically,

has a substantially rectangular cross-section.

Preferably, the support member further comprises end portions adapted to engage with support surfaces at either end of the elongate member to support the elongate member between the support surfaces.

Preferably, a number of engagement means are provided at discrete locations along the side wall of the elongate members such that the positions of the tie members are adjustable.

Typically, the engagement means comprise slots which are preferably substantially parallel to the central longitudinal axis of the elongate member.

Preferably, the engagement means are provided on opposite sides of the elongate member and preferably on all four sides of the elongate member. This has the advantage of permitting the elongate member to be used to support two different thicknesses of walls if the elongate member has a rectangular cross-section.

Preferably, the support member is for supporting a brick or stone wall and the tie members are engaged with cement between bricks or stones forming the wall, in use.

Typically, the tie members are generally L-shaped with one

portion of the L engaging with the engagement means on the side wall and the other portion of the L engaging with the wall to be supported.

Preferably, the support member is adapted to be used to support a wall with the support member in a substantially vertical orientation or in a substantially horizontal orientation.

Typically, the elongate members are formed from a metal, such as steel.

An example of a support member in accordance with the invention will now be described with reference to the accompanying drawings, in which:-

Figure 1 is a perspective view of a brick wall having vertical and horizontal stiffeners to support the wall;
Figure 2 is an enlarged and exploded view of region A of Figure 1 showing the upper end of the vertical stiffener;

Figure 3 is an enlarged and exploded view of region B of Figure 1 showing attachment of a tie to the vertical stiffener;

Figure 4 is an enlarged and exploded view of region C of Figure 1 showing a connector for coupling the horizontal stiffener to the vertical stiffener;

Figure 5 is an enlarged and exploded view of region D of

Figure 1 showing the lower end of the vertical stiffener;

Figure 6 is a perspective view of the tie shown in Figure 3; and

Figure 7 is a perspective view of a connector plate for use with the connector shown in Figure 4.

Figure 1 shows a section of a wall 1 which is supported by a number of vertical stiffeners 2 (only one shown) which are interconnected by a number of horizontal stiffeners 3 (only two shown). As shown in Figure 1, the vertical stiffener 2 supports three portions 4, 5, 6 of the wall 1 and the vertical edges of the portions 4, 5, 6 adjacent to the vertical stiffener 2 are mechanically connected to the stiffener 2 by means of a number of ties 7.

The vertical stiffener 2 is connected at each of its upper and lower ends to an upper support surface 8 and to a lower support surface 9, respectively by a connector 10. In addition, each end of the horizontal stiffeners 3 are connected to the side of the vertical stiffener 2 by a connector 11.

Each of the vertical and horizontal stiffeners 2, 3 comprise a hollow rectangular box section defined by side walls 30, 31. Typically, the side walls 30 are approximately half the width of side walls 31. The side walls 30, 31 each have a number of slots 22, 24 which extend in a direction

substantially parallel to the longitudinal axis of the stiffeners 2, 3. Each slot 22, 24 also has a respective opening 45, 46.

An exploded and enlarged view of the connectors 10 at the upper and lower ends of the vertical stiffener 2 are shown in more detail in Figures 2 and 5. Connectors 10 include a hollow box section 12 defined by two side walls 17, a side wall 18 and two partial side walls 40, 41. From the side wall 18 extends a bent over section 13 and bent over sections 14 extend from the two partial side walls 40, 41. The bent over sections 13, 14 enable a plate 15 to be slid between the bent over sections 13, 14 and ends 16 of the side walls 17. The widths of the side walls 17 and the side wall 18 is less than or equal to the internal dimensions of the vertical stiffener 2 such that the box section 12 may be inserted into the upper and lower ends of the vertical stiffener 2.

As shown in Figures 2 and 5, the plate 15 has two pairs of holes 19 through which mechanical fastener 42 may be inserted to attach the plate 15 to the underside of the upper support surface 8 and the upper side of the lower support surface 9. The mechanical fasteners 42 are preferably powder actuated fasteners but may, alternatively, be any type of suitable fastener, such as nails, masonry nails or screws.

An enlarged and exploded view of region B in Figure 1 is shown in Figure 3 where it can be seen that the ties 7

include a planar section 20 which has two lugs 21 formed thereon. The lugs can be inserted through openings 45, 46 to engage with slots 22, 24 in the side wall of the stiffener 2 to attach the tie 7 to the side wall 30. The length of the slots 22, 24 is greater than the length of the lugs 21 to permit movement of the tie 7, and, therefore, adjustment of the position of the tie 7 with respect to the side wall 30. The planar section 20 of the tie 7 is connected to a ribbed section 23. The ribbed section 23 has a rib formation 25. The ribbed section 23 makes an angle of approximately 90° with the planar section 20, such that when the lugs 21 are inserted into the slots 22, the ribbed section 23 of the tie 7 extends substantially perpendicularly to the side wall 30 of the stiffener 2. A rear perspective view of the tie 7 is shown in Figure 6 where it can be seen that the lugs 21 extend both rearwardly and to the side of the planar section 20.

An enlarged and exploded view of region C of Figure 1 is shown in Figure 4 where the connector 11 is shown in more detail. The connector 11 includes the box section 12 which is identical to the box section 12 used in the connector 10. However, the connector 11 has a plate 26 inserted between the bent over sections 13, 14 (not shown in Figure 4) and the ends 16 of the side walls 17. The plates 26 have four lugs 27, 28 which engage with slots 24, 22 respectively in the side wall 30 of the vertical stiffener 2. The box section 12 fits into the end of the horizontal stiffener 3 so that the

connector 11 couples the horizontal stiffener 3 to the vertical stiffener 2.

The plate 26 is shown in more detail in Figure 7. It can be seen that the plate 26 is symmetrical about a rotation of 180° around an axis through the center of the plate 26 and perpendicular to the surface of plate 26. The lugs 28, 27 are formed by punching out sections of the plate 26 to form the lugs 28, 27 which extend rearwardly behind the plate 26. This permits the rear surface of the plate 26 to be placed against the external surface of the wall 30 and the lugs 28, 27 inserted through the openings 45, 46, respectively to engage in respective slots 22, 24 in the wall 30 to attach plate 26 (and therefore the connector 11) to the vertical stiffener 2.

In use, the stiffeners 2, 3 are installed by first installing the vertical stiffener 2. The vertical stiffener 2 is installed by inserting connectors 10 into the upper and lower ends of the stiffener 2 and positioning the stiffener 2 where desired. When the stiffener 2 is in the correct position, fasteners 42 are driven through the holes 19 in the plates 15 to secure the connectors 10 to the upper and lower support surfaces 8, 9 and thereby retain the vertical stiffener 2 in the correct position.

Typically, the length of the vertical stiffener 2 is chosen to be nominally shorter than the height of the vertical gap

into which the stiffener has to fit and the depth of the box sections 12 facilitate adjustment to ensure that the combination of the connectors 10 and stiffener 2 extend from the lower support surface 9 to the upper support surface 8. It is not essential that the box section 12 on the upper connector 10 is fully inserted into the upper end of the stiffener 2, it is sufficient that only a portion of the box section 12 is inserted into the upper end of the stiffener 2. Hence, this facilitates adjustment of the height of the stiffener 2 to take account differences and tolerances between the designed height of the wall 1 and the actual height of the wall 1.

After the vertical stiffener 2 has been installed, the wall 1 is constructed and ties 7 are mounted at appropriate intervals (typically every third or fourth layer of bricks) on the side walls 30 of the vertical stiffener 2 such that the ribbed section 23 is mechanically locked to the wall 1 by the ribbed portion 23 being located between layers of bricks and held by the cement between the layers. When the lower portions 4, 5 are constructed to a level where the horizontal stiffener 3 is required, the last layer of bricks is completed except for the two end bricks adjacent the vertical stiffener. The connectors 11 are inserted into each end of a horizontal stiffener 3 and the lugs in the plate 26 of the connectors 11 are inserted into the slots 22, 24 in the side walls 30 of adjacent vertical stiffeners 2 to mount the horizontal stiffener above the last layer of bricks. Each

end brick is then laid. Continuation of construction of the wall 1 above the horizontal stiffener 3 then continues by construction of the wall portion 6 above the stiffeners 3, with ties 7 inserted along the side 30 of the stiffener 2 at appropriate intervals to engage between the adjacent layers of bricks to tie the wall portion 6 to the vertical stiffener 2.

Accordingly, the invention has the advantage that provision of a metal stiffener onto which ties may be mounted, makes installation of the stiffeners 2, 3 more straightforward than the conventional method of using concrete stiffeners. It also has the advantage of reducing the need for a number of different tradesman being required to construct and erect the stiffener.

The use of slots 22, 24 has the advantage of permitting vertical adjustment of the ties 7 with respect to the stiffeners 2, 3 and vertical adjustment of the horizontal stiffeners 3 to the vertical stiffeners 2. The adjustment is further enhanced by the distribution of a number of slots 22, 24 across the surfaces of the side walls 30, 31.

In addition, as the side wall 31 is twice the width of the side wall 30, by using the ties 7 on the side wall 31 permits the stiffeners 2, 3 to be used to support a thicker wall. Hence, the stiffeners 2, 3 can be used to support two different wall thicknesses.

The slots also have the advantage of aiding adhesion of plaster to the stiffeners 2, 3 by helping the plaster to key to the metal surface. In addition, the recessed nature of the side walls 30, by making the separation of the side walls 30 less than the width of the side walls 31, also aids retention of plaster on to the side walls 30. This is less critical on the side walls 31, as the side walls 31 are narrower. However, the side walls 31 could also be recessed if desired.

CLAIMS

1. A support member comprising an elongate member having a side wall adapted to be located adjacent an end of a structure to be supported, in use, the side wall including a number of engagement means which permit a tie member to be mounted on the side wall, the tie member having a portion projecting from the side wall to engage with the structure to be supported.
2. A support member according to claim 1, wherein the elongate member is hollow.
3. A support member according to claim 1 or claim 2, wherein the elongate member has a substantially rectangular cross-section.
4. A support member according to any of the preceding claims, and further comprising first end portions adapted to engage with support surfaces at either end of the elongate member to support the elongate member between the support surfaces, in use.
5. A support member according to any of the preceding claims, wherein a number of engagement means are provided at discrete locations along the side wall.
6. A support member according to any of the preceding

claims, wherein the engagement means comprises a slot.

7. A support member according to claim 6, wherein the slot is substantially parallel to the central longitudinal axis of the elongate member.

8. A support member according to any of the preceding claims, wherein the tie member comprises a first portion adapted to engage with the engagement means and a second portion adapted to project from the side wall of the elongate member when the first portion is engaged with the engagement means.

9. A support member according to claim 8, wherein the first and second portion form a generally "L" shape.

10. A support member according to claim 8 or claim 9 when dependent on claim 6 or claim 7, wherein the first portion of the tie member comprises a formation which is adapted to engage with the slot.

11. A support member according to any of the preceding claims, wherein the engagement means are provided in each side wall of the elongate member.

12. A first support member according to any of claim 1 to 3 and further comprising second end portions adapted to engage with engagement means on a second support member according to

any of the preceding claims, to support the first support member in a substantially horizontal orientation in use when the second support member is in a substantially vertical orientation in use.

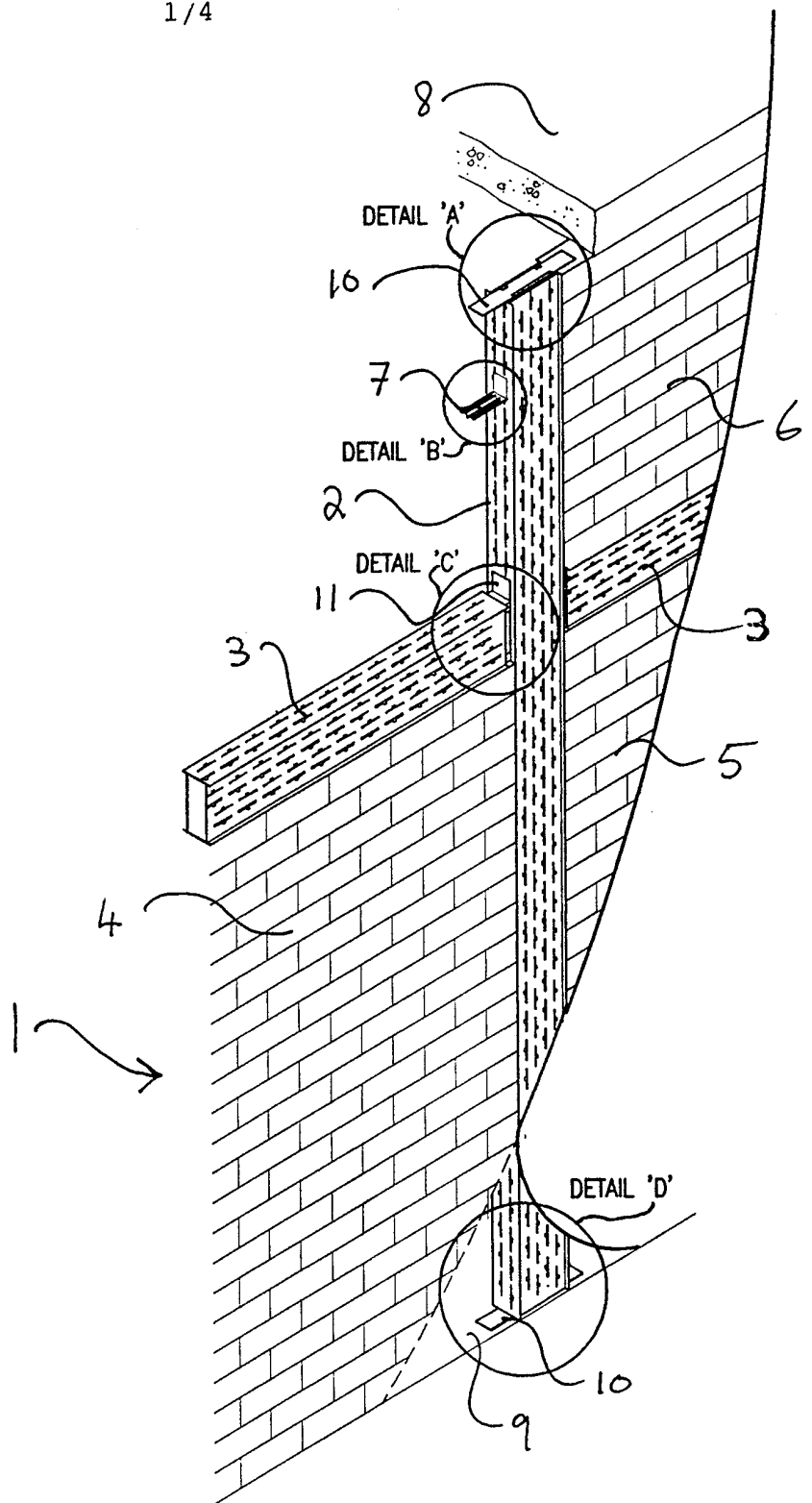

Figure 1

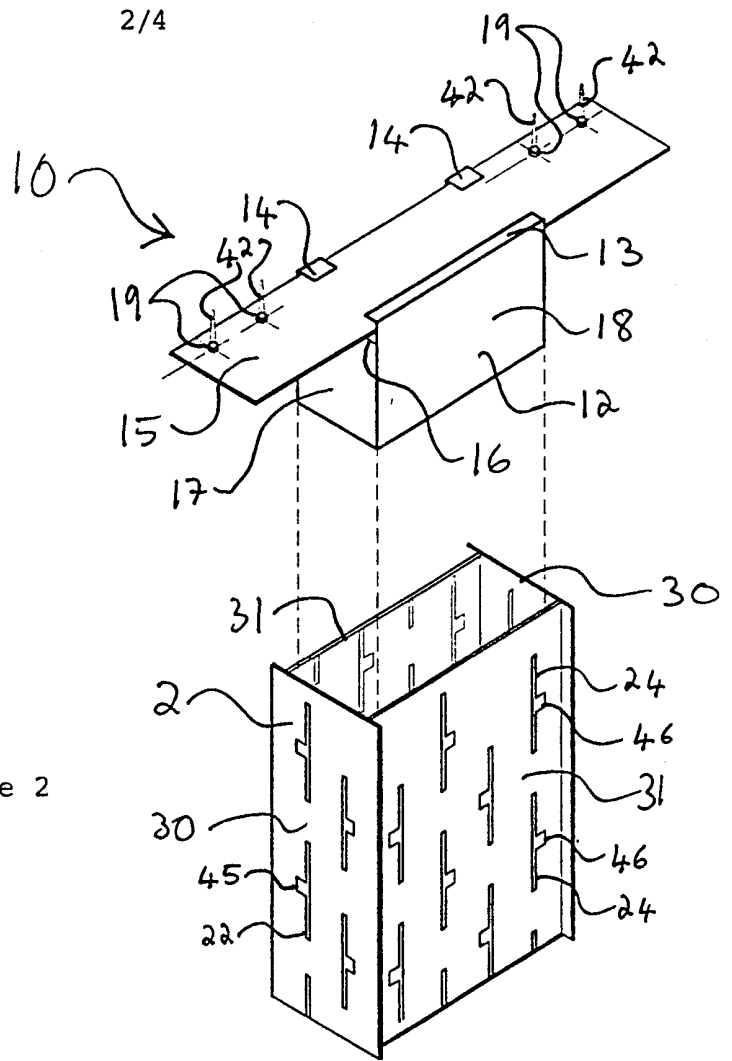

Figure 2

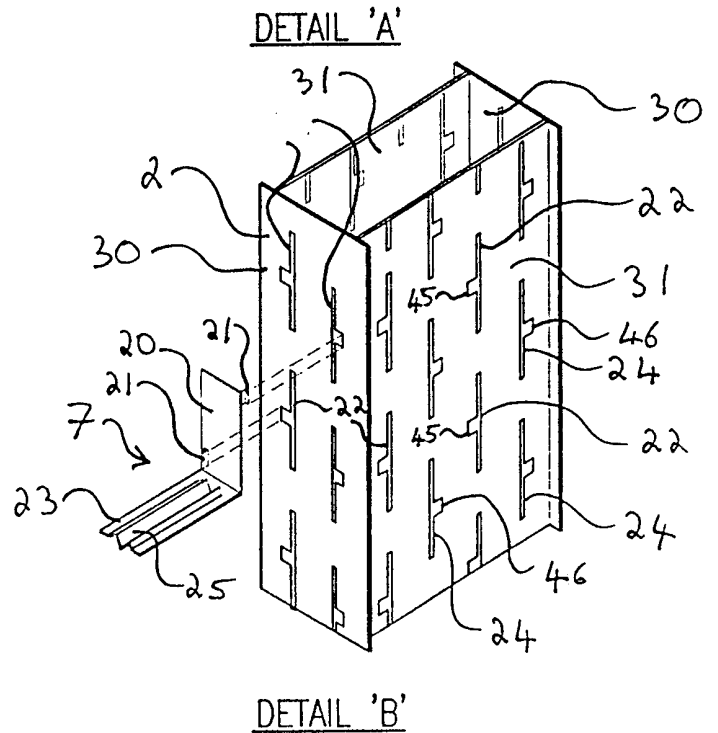

Figure 3

3/4

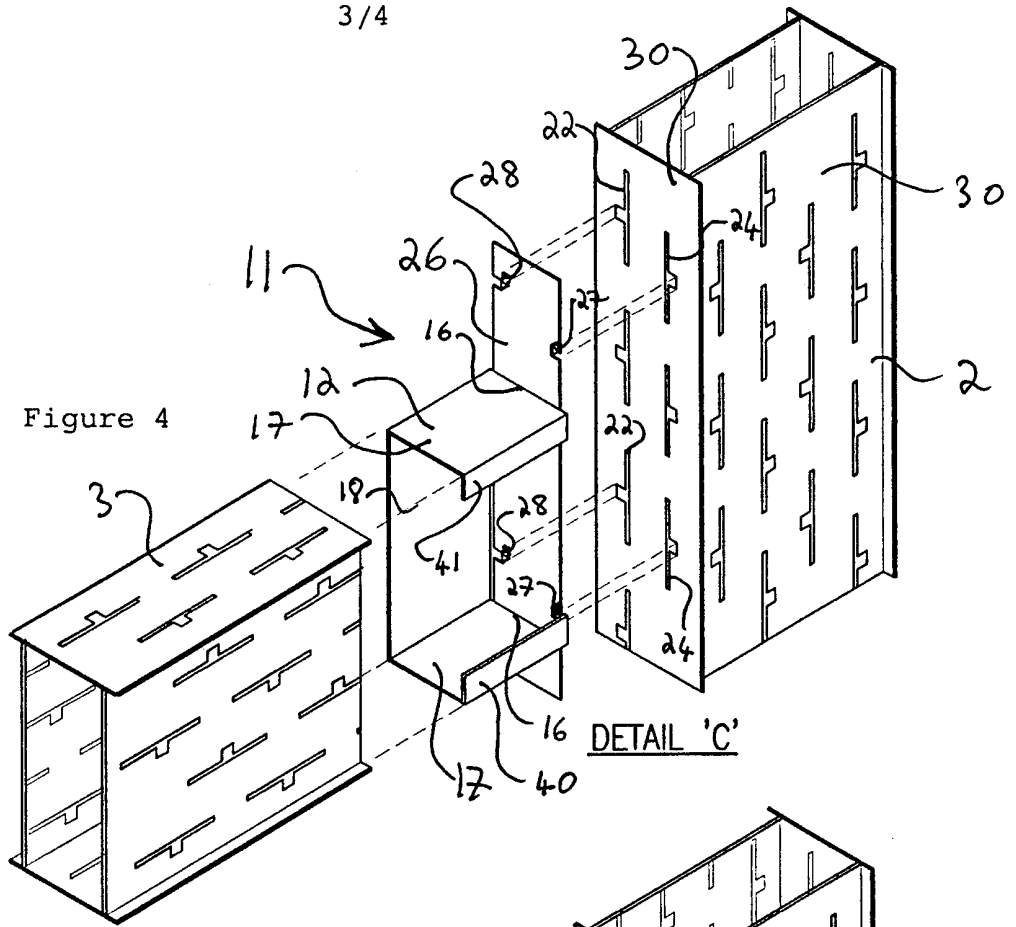
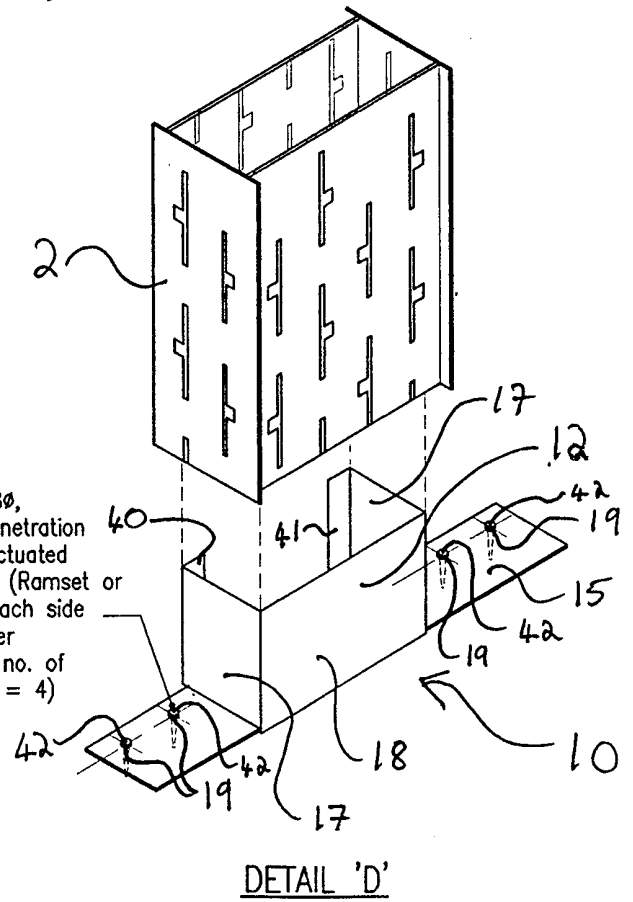

Figure 5

2 No. 3.80,
38mm penetration
Powder Actuated
Fasteners (Ramset or
similar) each side
of stiffener
(i.e total no. of
fasteners = 4)



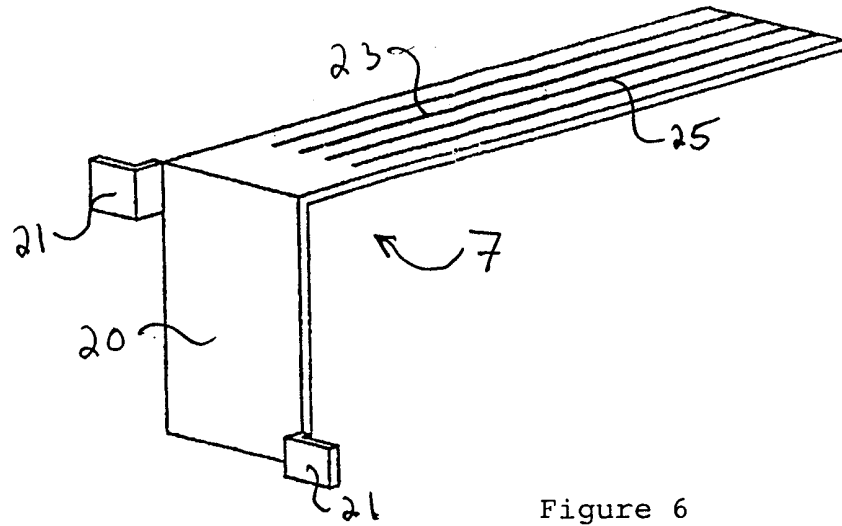

Figure 6

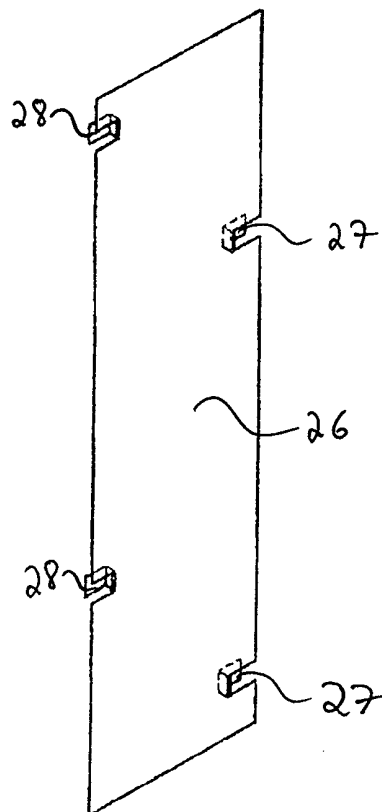

Figure 7

INTERNATIONAL SEARCH REPORT

International application No.
PCT/SG 98/00030

A. CLASSIFICATION OF SUBJECT MATTER IPC ⁶ : E 04 B 2/06, 2/58 According to International Patent Classification (IPC) or to both national classification and IPC		
B. FIELDS SEARCHED Minimum documentation searched (classification system followed by classification symbols) IPC ⁶ : E 04 B 2/06, 2/30, 2/56, 2/58, 2/60 Documentation searched other than minimum documentation to the extent that such documents are included in the fields searched Electronic data base consulted during the international search (name of data base and, where practicable, search terms used)		
C. DOCUMENTS CONSIDERED TO BE RELEVANT		
Category*	Citation of document, with indication, where appropriate, of the relevant passages	Relevant to claim No.
A	DE 36 02 308 A1 (MODERSOHN) 30 July 1987 (30.07.87), fig.1,2.	1,5-7,10
A	GB 2 220 430 A (HEELAN) 10 January 1990 (10.01.90), fig.1,3.	1
A	DE 28 49 882 A1 (SCHMIEDTBAUER & STUMMER) 07 June 1979 (07.06.79), fig.1.	5-10
A	DE 86 32 059 U1 (VELINGS) 19 February 1987 (19.02.87), fig.1a,1b.	1

<input type="checkbox"/> Further documents are listed in the continuation of Box C. <input checked="" type="checkbox"/> See patent family annex.		
* Special categories of cited documents: "A" document defining the general state of the art which is not considered to be of particular relevance "T" later document published after the international filing date or priority date and not in conflict with the application but cited to understand the principle or theory underlying the invention "E" earlier application or patent but published on or after the international filing date "X" document of particular relevance; the claimed invention cannot be considered novel or cannot be considered to involve an inventive step when the document is taken alone "L" document which may throw doubts on priority claim(s) or which is cited to establish the publication date of another citation or other special reason (as specified) "Y" document of particular relevance; the claimed invention cannot be considered to involve an inventive step when the document is combined with one or more other such documents, such combination being obvious to a person skilled in the art "O" document referring to an oral disclosure, use, exhibition or other means "P" document published prior to the international filing date but later than the priority date claimed "&" document member of the same patent family		
Date of the actual completion of the international search 07 December 1998 (07.12.98)		Date of mailing of the international search report 17 December 1998 (17.12.98)
Name and mailing address of the ISA/ Austrian Patent Office Kohlmarkt 8-10; A-1014 Vienna Facsimile No. 1/53424/535		Authorized officer Knauer Telephone No. 1/53424/416

INTERNATIONAL SEARCH REPORT

Information on patent family members

International application No.

PCT/SG 98/00030

Im Recherchenbericht angeführtes Patentdokument Patent document cited in search report Document de brevet cité dans le rapport de recherche	Datum der Veröffentlichung Publication date Date de publication	Mitglied(er) der Patentfamilie Patent family member(s) Membre(s) de la famille de brevets	Datum der Veröffentlichung Publication date Date de publication
DE A1 3602308	30-07-87	DE C2 3602308	16-06-94
GB A 2220430		GB A0 8816340	10-08-88
		GB A0 8915581	23-08-89
		GB A1 2220430	10-01-90
		GB B2 2220430	29-04-92
DE A1 2849882	07-06-79	AT A 8753777	15-08-79
		AT B 355760	25-03-80
DE U1 8632059	02-04-87	BE A2 905844	01-06-87
		NL A 8503322	01-07-87
		NL B 191468	16-03-95
		NL C 191468	18-07-95