

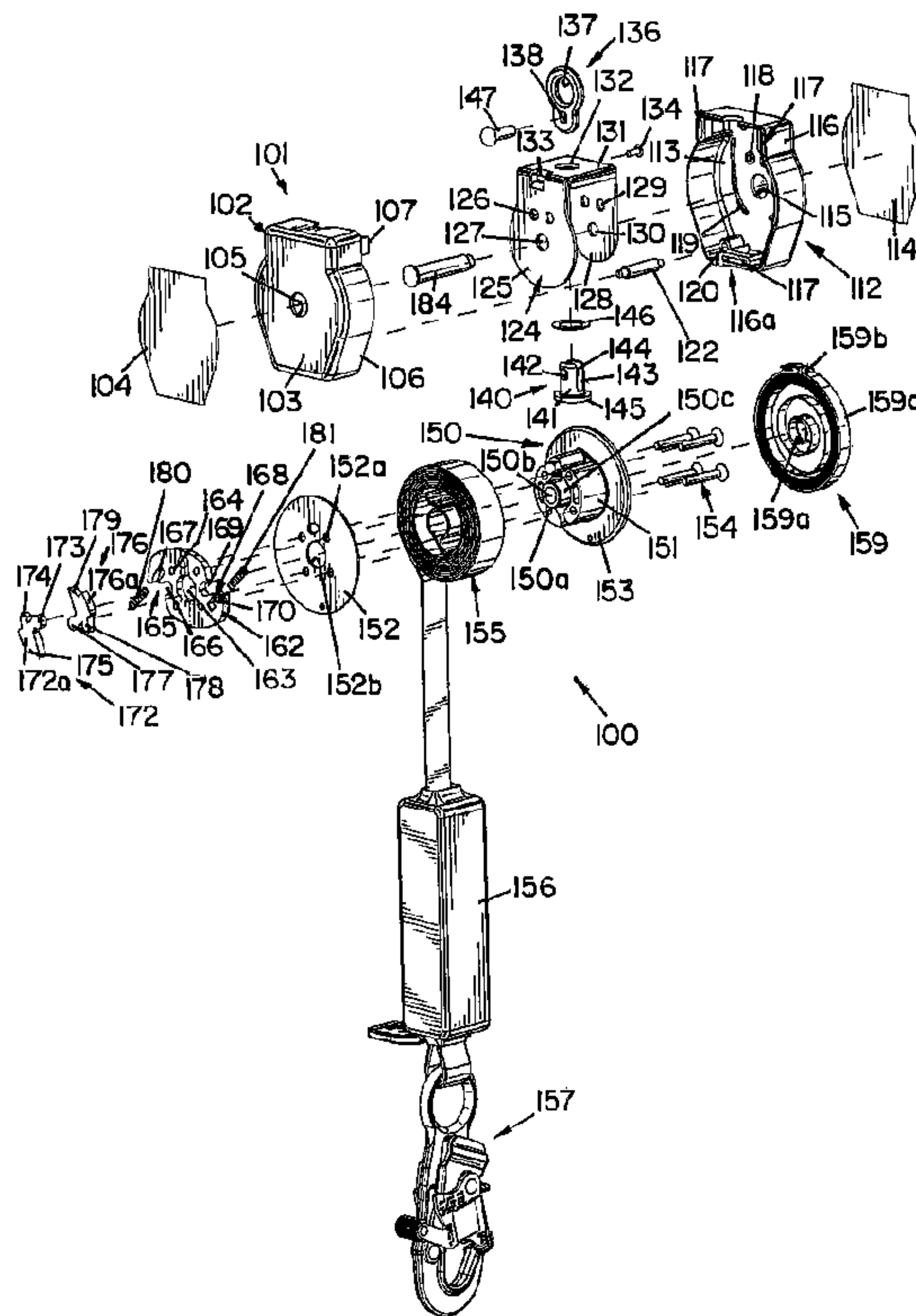

(86) Date de dépôt PCT/PCT Filing Date: 2012/10/26
 (87) Date publication PCT/PCT Publication Date: 2013/05/02
 (45) Date de délivrance/Issue Date: 2019/05/07
 (85) Entrée phase nationale/National Entry: 2014/03/18
 (86) N° demande PCT/PCT Application No.: US 2012/062153
 (87) N° publication PCT/PCT Publication No.: 2013/063414
 (30) Priorités/Priorities: 2011/10/28 (US61/552,530);
 2012/10/25 (US13/660,262)

(51) Cl.Int./Int.Cl. *A62B 1/10* (2006.01),
A62B 35/00 (2006.01), *F16D 59/00* (2006.01),
F16M 13/00 (2006.01)
 (72) Inventeur/Inventor:
 CASEBOLT, SCOTT C., US
 (73) Propriétaire/Owner:
 D B INDUSTRIES, LLC, US
 (74) Agent: SMART & BIGGAR

(54) Titre : CORDE DE COMMUNICATION AUTO-RETRACTABLE
 (54) Title: SELF-RETRACTING LIFELINE



(57) Abrégé/Abstract:

A self-retracting lifeline comprises a drum including first and second sides operatively connected to a base. A rotor includes a receiving portion and is operatively connected to the base. A pawl is pivotally operatively connected to the rotor, and a biasing member is positioned between the rotor and the pawl to place a biasing force upon the pawl. A bracket member includes a cavity and a stop member extending into the cavity. The cavity is configured and arranged to receive the drum, the rotor, the pawl, and the spring. The drum is rotatably operatively connected to the bracket member and the pawl is positioned proximate the stop member. The pawl and the biasing member are held in place by the first side of the base, the rotor, and the bracket member.

(12) INTERNATIONAL APPLICATION PUBLISHED UNDER THE PATENT COOPERATION TREATY (PCT)

(19) World Intellectual Property
Organization
International Bureau(10) International Publication Number
WO 2013/063414 A3(43) International Publication Date
2 May 2013 (02.05.2013)

(51) International Patent Classification:

A62B 1/10 (2006.01) F16M 13/00 (2006.01)
A62B 35/00 (2006.01) F16D 59/00 (2006.01)

(21) International Application Number:

PCT/US2012/062153

(22) International Filing Date:

26 October 2012 (26.10.2012)

(25) Filing Language:

English

(26) Publication Language:

English

(30) Priority Data:

61/552,530 28 October 2011 (28.10.2011) US
13/660,262 25 October 2012 (25.10.2012) US

(71) Applicant: **D B INDUSTRIES, INC.** [US/US]; 3833 Sala Way, Red Wing, MN 55066 (US).(72) Inventor: **CASEBOLT, Scott, C.**; 1460 Laurel Avenue, St. Paul Park, MN 55071 (US).(74) Agent: **MAU, Michael, L.**; IPLM Group, P.A., Post Office Box 18455, Minneapolis, MN 55418 (US).

(81) Designated States (unless otherwise indicated, for every kind of national protection available): AE, AG, AL, AM, AO, AT, AU, AZ, BA, BB, BG, BH, BN, BR, BW, BY,

BZ, CA, CH, CL, CN, CO, CR, CU, CZ, DE, DK, DM, DO, DZ, EC, EE, EG, ES, FI, GB, GD, GE, GH, GM, GT, HN, HR, HU, ID, IL, IN, IS, JP, KE, KG, KM, KN, KP, KR, KZ, LA, LC, LK, LR, LS, LT, LU, LY, MA, MD, ME, MG, MK, MN, MW, MX, MY, MZ, NA, NG, NI, NO, NZ, OM, PA, PE, PG, PH, PL, PT, QA, RO, RS, RU, RW, SC, SD, SE, SG, SK, SL, SM, ST, SV, SY, TH, TJ, TM, TN, TR, TT, TZ, UA, UG, US, UZ, VC, VN, ZA, ZM, ZW.

(84) Designated States (unless otherwise indicated, for every kind of regional protection available): ARIPO (BW, GH, GM, KE, LR, LS, MW, MZ, NA, RW, SD, SL, SZ, TZ, UG, ZM, ZW), Eurasian (AM, AZ, BY, KG, KZ, RU, TJ, TM), European (AL, AT, BE, BG, CH, CY, CZ, DE, DK, EE, ES, FI, FR, GB, GR, HR, HU, IE, IS, IT, LT, LU, LV, MC, MK, MT, NL, NO, PL, PT, RO, RS, SE, SI, SK, SM, TR), OAPI (BF, BJ, CF, CG, CI, CM, GA, GN, GQ, GW, ML, MR, NE, SN, TD, TG).

Declarations under Rule 4.17:

- as to applicant's entitlement to apply for and be granted a patent (Rule 4.17(ii))
- as to the applicant's entitlement to claim the priority of the earlier application (Rule 4.17(iii))

[Continued on next page]

(54) Title: SELF-RETRACTING LIFELINE

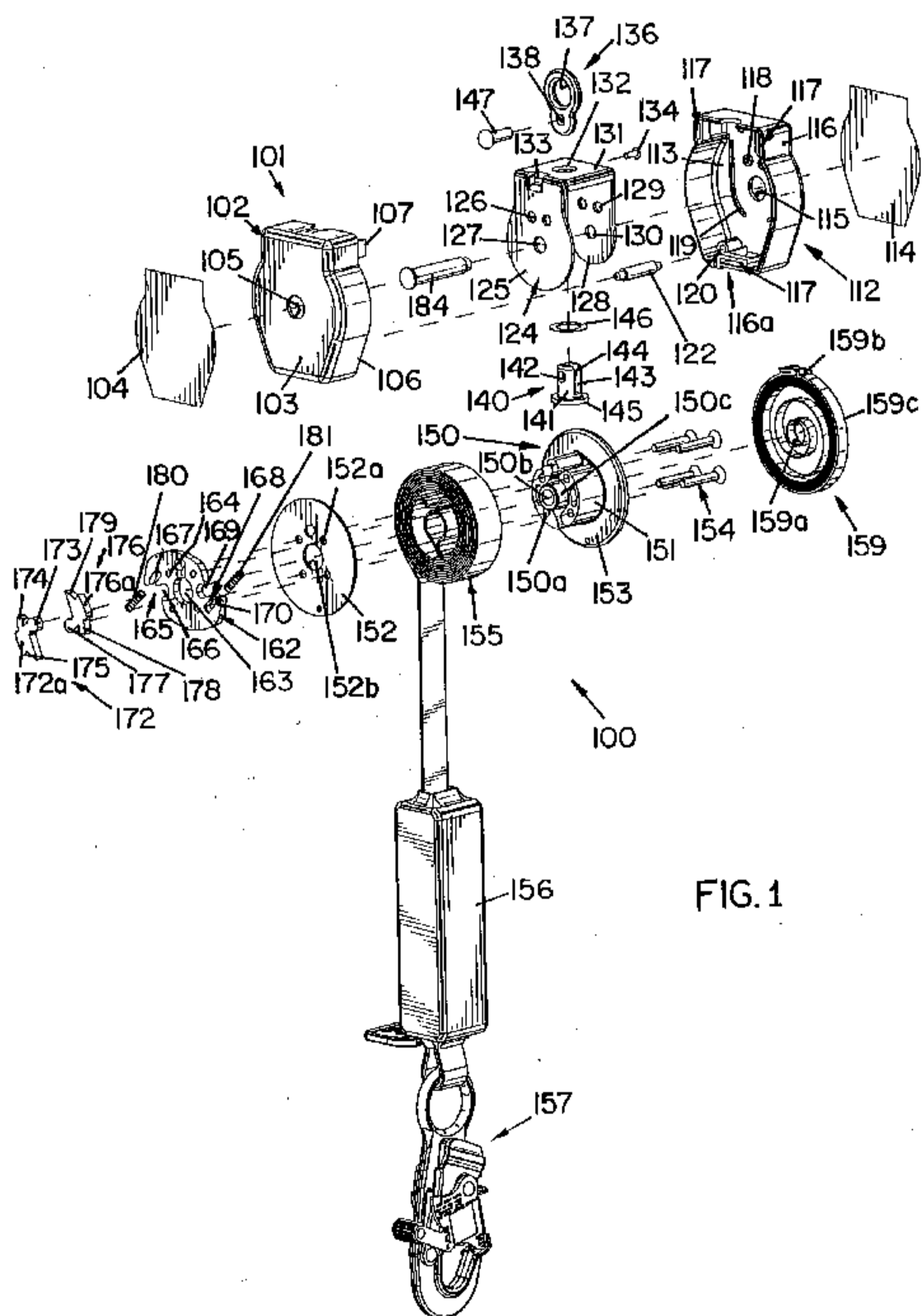

(57) Abstract: A self-retracting lifeline comprises a drum including first and second sides operatively connected to a base. A rotor includes a receiving portion and is operatively connected to the base. A pawl is pivotally operatively connected to the rotor, and a biasing member is positioned between the rotor and the pawl to place a biasing force upon the pawl. A bracket member includes a cavity and a stop member extending into the cavity. The cavity is configured and arranged to receive the drum, the rotor, the pawl, and the spring. The drum is rotatably operatively connected to the bracket member and the pawl is positioned proximate the stop member. The pawl and the biasing member are held in place by the first side of the base, the rotor, and the bracket member.

WO 2013/063414 A3 

Published:

— *with international search report (Art. 21(3))*

(88) Date of publication of the international search report:
14 November 2013

SELF-RETRACTING LIFELINE

BACKGROUND OF THE INVENTION

[0001] Self-retracting lifelines are well known in the art of fall protection safety equipment for use by workers performing tasks during which there is a risk a fall may occur. Self-retracting lifelines generally include a housing containing a drum around which a lifeline such as a cable, a rope, or webbing is wound. The drum is spring biased to pay out the lifeline as tension pulling the lifeline is applied and to retract any of the lifeline that has been unwound from the drum as the tension on the lifeline is reduced or released. The housing also includes a brake assembly for stopping rotation of the drum when the cable suddenly unwinds from the drum at a rate greater than a predetermined maximum rotational velocity.

[0002] A self-retracting lifeline is typically connected to a support structure within the vicinity the worker is performing the task and to a safety harness worn by the worker. Depending upon the type of task being performed, either the housing or the end of the lifeline is connected to the support structure and the other is connected to the safety harness worn by the worker. The lifeline is easily drawn out of the self-retracting lifeline housing as the worker moves away from the device, and the lifeline is automatically drawn back into the housing as the worker moves toward the device. Should a fall occur, a brake member within the device, such as but not limited to a ratchet member or a stop member, is automatically engaged by a centrifugal brake assembly, which stops the worker's fall by stopping the rotation of the drum when the lifeline unwinds from the drum at a rotational velocity greater than a predetermined maximum rotational velocity. As the rotation of the drum is stopped, additional lifeline is prevented from being paid out of the housing to stop the fall of the worker.

[0003] It is desired to have a relatively small, lightweight self-retracting lifeline that can be used by itself or with a second self-retracting lifeline.

[0004] For the reasons stated above and for other reasons stated below, which will become apparent to those skilled in the art upon reading and understanding the present specification, there is a need in the art for an improved self-retracting lifeline.

BRIEF SUMMARY OF THE INVENTION

[0005] The above-mentioned problems associated with prior devices are addressed by embodiments of the present invention and will be understood by reading and understanding the present specification. The following summary is made by way of example and not by way of limitation. It is merely provided to aid the reader in understanding some of the aspects of the invention.

[0005a] According to an aspect of the present invention, there is provided a centrifugal brake assembly, comprising: at least one pawl including a base from which a circular portion and a triangular protrusion extend; at least one biasing member; a rotor including at least one receiving portion having a notched portion being configured and arranged to receive the circular portion; one of the at least one pawl and the rotor having a slotted portion, another of the at least one pawl and the rotor having a protrusion, the slotted portion being configured and arranged to receive the protrusion and the at least one biasing member, the protrusion and the at least one biasing member extending generally in line with one another within the slotted portion; and wherein the at least one pawl is pivotable about the circular portion relative to the rotor and the triangular protrusion of the at least one pawl is configured and arranged to engage a stop member when the at least one pawl is in an engaged position, the base contacting the rotor in the engaged position to reinforce the at least one pawl.

[0005b] According to another aspect of the present invention, there is provided a centrifugal brake assembly, comprising: at least one pawl including a base from which a circular portion and a triangular protrusion extend; at least one biasing member; a rotor including at least one receiving portion having a notched portion being configured and arranged to receive the circular portion; one of the at least one pawl and the rotor having a curved slotted portion, said biasing member seated within the slotted portion, another of the at least one pawl and the rotor having a curved elongated protrusion extending in line with the curved slotted portion and the biasing member, the slotted portion being configured and arranged to receive the protrusion and the at least one biasing member, the slotted portion and the protrusion each being separate from the respective notched portion or circular portion; and wherein the at least one pawl is pivotable about the circular portion relative to the rotor and

the triangular protrusion of the at least one pawl is configured and arranged to engage a stop member when the at least one pawl is in an engaged position, the base contacting the rotor in the engaged position to reinforce the at least one pawl.

[0005c] According to another aspect of the present invention, there is provided a centrifugal brake assembly, comprising: a first pawl including a first base from which a first circular portion, a first triangular protrusion, and a first protrusion extend, the first circular portion, the first triangular protrusion, and the first protrusion extending separately from the first base; a second pawl including a second base from which a second circular portion, a second triangular protrusion, and a second protrusion extend, the second circular portion, the second triangular protrusion, and the second protrusion extending separately from the second base; a first biasing member; a second biasing member; a rotor including a first receiving portion and a second receiving portion, the first receiving portion having a first notched portion configured and arranged to receive the first circular portion and a first curved slotted portion configured and arranged to receive the first protrusion and the first biasing member, the second receiving portion having a second notched portion configured and arranged to receive the second circular portion and a second curved slotted portion configured and arranged to receive the second protrusion and the second biasing member; the first and second biasing members seated within a respective of the slotted portions; each of the first and second protrusions comprises a curved elongated member extending in line with the curved slotted portion and the biasing member; and wherein each of the first and second pawls is pivotable about its circular portion relative to the rotor and its triangular protrusion forms a notched pawl portion configured and arranged to engage a stop member when the pawl is in an engaged position, an opposing side of the base from the triangular protrusion contacting the rotor in the engaged position to reinforce the pawl.

[0005d] According to another aspect of the present invention, there is provided a centrifugal brake assembly, comprising: at least one pawl including a base from which a pivoting portion and an engaging portion extend; at least one biasing member; a rotor including at least one receiving portion configured and arranged to receive the pivoting portion; one of the at least one pawl and the rotor having a curved slotted portion, another of the at least one pawl and the rotor having a protrusion, the slotted portion being configured

and arranged to receive the protrusion and the at least one biasing member; said biasing member seated within the slotted portion; said protrusion comprises a curved elongated member extending generally in line with the curved slotted portion and the biasing member, the slotted portion and the protrusion each being separate from a respective notched portion or circular portion, the at least one biasing member being positioned between a surface forming an end of the slotted portion and the protrusion and placing a biasing force on the protrusion to position the at least one pawl in a disengaged position, the biasing member being compressible to position the at least one pawl in an engaged position; and wherein the at least one pawl is pivotable about the pivoting portion relative to the rotor and the engaging portion of the at least one pawl is configured and arranged to engage a stop member when the at least one pawl is in an engaged position, the base contacting the rotor in the engaged position to reinforce the at least one pawl.

[0005e] According to another aspect, there is provided a centrifugal brake assembly, comprising: at least one pawl including a base from which a circular portion extends; at least one biasing member; a rotor including at least one receiving portion having a notched portion being configured and arranged to receive the circular portion; one of the at least one pawl and the rotor having a curved slotted portion, the at least one biasing member being seated within the curved slotted portion, another of the at least one pawl and the rotor having a curved elongated protrusion extending in line with the curved slotted portion and the at least one biasing member; and wherein the at least one pawl is pivotable about the circular portion relative to the rotor and the at least one pawl is configured and arranged to engage a stop member when the at least one pawl is in an engaged position.

[0005f] According to another aspect, there is provided a centrifugal brake assembly, comprising: a first pawl including a first base from which a first circular portion and a first protrusion extend; a second pawl including a second base from which a second circular portion and a second protrusion extend; a first biasing member; a second biasing member; a rotor including a first receiving portion and a second receiving portion, the first receiving portion having a first notched portion configured and arranged to receive the first circular portion and a first curved slotted portion configured and arranged to receive the first protrusion and the first biasing member, the second receiving portion having a second notched

portion configured and arranged to receive the second circular portion and a second curved slotted portion configured and arranged to receive the second protrusion and the second biasing member, the first and second biasing members seated within a respective of the curved slotted portions, each of the first and second protrusions comprises a curved elongated member extending in line with a respective of the curved slotted portions and the biasing members; and wherein each of the first and second pawls is pivotable about its circular portion relative to the rotor and is configured and arranged to engage a stop member when the pawl is in an engaged position.

[0005g] According to another aspect, there is provided a centrifugal brake assembly, comprising: at least one pawl including a base from which a pivoting portion and an engaging portion extend; at least one biasing member; a rotor including at least one receiving portion configured and arranged to receive the pivoting portion; one of the at least one pawl and the rotor having a curved slotted portion, the at least one biasing member being seated within the curved slotted portion, another of the at least one pawl and the rotor having a curved elongated protrusion extending in line with the curved slotted portion and the at least one biasing member, the at least one biasing member being positioned between a surface forming an end of the curved slotted portion and the curved elongated protrusion and placing a biasing force on the curved elongated protrusion to position the at least one pawl in a disengaged position, the biasing member being compressible to position the at least one pawl in an engaged position; and wherein the at least one pawl is pivotable about the pivoting portion relative to the rotor and the engaging portion of the at least one pawl is configured and arranged to engage a stop member when the at least one pawl is in an engaged position.

[0005h] According to another aspect, there is provided a centrifugal brake assembly, comprising: at least one pawl including a base from which a circular portion and a protrusion directly extend, wherein the circular portion is spaced from the protrusion; and a rotor comprising: at least one receiving portion having a notched portion configured and arranged to receive the circular portion; and a slotted portion configured and arranged to receive the protrusion; wherein the at least one pawl is pivotable about the circular portion relative to the rotor.

[0005i] According to another aspect, there is provided a centrifugal brake assembly, comprising: at least one pawl including a base from which a circular portion extends; at least one biasing member; a rotor including at least one receiving portion having a notched portion being configured and arranged to receive the circular portion; one of the at least one pawl and the rotor having a slotted portion, another of the at least one pawl and the rotor having a protrusion, the slotted portion being configured and arranged to receive the protrusion and the at least one biasing member, the protrusion and the at least one biasing member extending generally in line with one another within the slotted portion; and wherein the at least one pawl is pivotable about the circular portion relative to the rotor.

[0006] In one embodiment, a self-retracting lifeline comprises a drum, a rotor, at least one pawl, at least one spring, and a bracket member. The drum includes a base to which a lifeline is operatively connected and first and second sides operatively connected to opposing sides of the base. The rotor includes at least one receiving portion and is operatively connected to the base. The at least one pawl is pivotally operatively connected to the rotor, and the at least one biasing member is positioned between the rotor and the at least one pawl to place a biasing force upon the at least one pawl. The at least one pawl has a disengaged position and an engaged position. The bracket member includes a cavity and a stop member extending into the cavity. The cavity is configured and arranged to receive the drum, the lifeline, the rotor, the at least one pawl, and the at least one spring. The drum is rotatably operatively connected to the bracket member and the at least one pawl is positioned proximate the stop member. The at least one pawl and the at least one biasing member are held in place by the first side of the base, the rotor, and the bracket member.

[0007] In one embodiment, a bracket member for use with a self-retracting lifeline comprises a first portion and a second portion operatively connected to the first portion. A first slot extends from the first portion to the second portion, and a second slot extends from the first portion to the second portion approximately parallel to the first slot. The first slot and the second slot form a stop member therebetween, and the stop member is bent to extend outward from the first portion and the second portion.

[0008] In one embodiment, a centrifugal brake assembly comprises at least one pawl including a base from which a circular portion and a triangular protrusion extend and at least one biasing member. A rotor includes at least one receiving portion having a notched portion. The notched portion is configured and arranged to receive the circular portion. One of the at least one pawl and the rotor having a slotted portion and another of the at least one pawl and the rotor having a protrusion. The slotted portion is configured and arranged to receive the protrusion and the at least one biasing member. The at least one pawl is pivotable about the circular portion relative to the rotor and the triangular portion of the at least one pawl is configured and arranged to engage a stop member when the at least one pawl is in an engaged position. The base contacts the rotor in the engaged position to reinforce the at least one pawl.

BRIEF DESCRIPTION OF THE DRAWINGS

[0009] Embodiments of the present invention can be more easily understood, and further advantages and uses thereof can be more readily apparent, when considered in view of the detailed description and the following Figures in which:

[0010] Figure 1 is an exploded perspective view of a self-retracting lifeline constructed in accordance with the principles of an embodiment of the present invention;

[0011] Figure 2 is a front, partial cross section view of the self-retracting lifeline shown in Figure 1 to show a centrifugal brake assembly;

[0012] Figure 3 is a front, partial cross section view of the self-retracting lifeline shown in Figure 1 to show a pawl of the centrifugal brake assembly shown in Figure 2 in an engaged position; and

[0013] Figure 4 shows a self-retracting lifeline constructed in accordance with the principles of an embodiment of the present invention operatively connected to a safety harness.

[0014] In accordance with common practice, the various described features are not drawn to scale but are drawn to emphasize specific features relevant to embodiments of the

present invention. Reference characters denote like elements throughout the Figures and the text.

DETAILED DESCRIPTION OF EMBODIMENTS

[0015] In the following detailed description, reference is made to the accompanying drawings, which form a part hereof, and in which is shown by way of illustration embodiments in which the inventions may be practiced. These embodiments are described in sufficient detail to enable those skilled in the art to practice the invention, and it is to be understood that other embodiments may be utilized and mechanical changes may be made without departing from the spirit and scope of the present invention. The following detailed description is,

therefore, not to be taken in a limiting sense, and the scope of the present invention is defined only by the claims and equivalents thereof.

[0016] As shown in Figures 1, 2, and 3, an embodiment self-retracting lifeline 100 includes a housing 101, which includes a first portion 102 and a second portion 112 that define a cavity 121 therebetween. The first portion 102 includes a plate portion 103 with an aperture 105 proximate the center and sides 106 extending approximately perpendicularly outward from the edges of the plate portion 103. A cover 104, which could be a product label including a variety of information, is configured and arranged to be operatively connected to the plate portion 103 and cover the aperture 105. The top right and left corners and the center of the bottom include protrusions 107 extending outward from the plate portion 103 parallel with the direction the sides 106 extend. The protrusions 107 include hook-like portions (not shown) proximate the distal ends. Proximate one side of the protrusion 107 located proximate the center of the bottom, the side 106 includes a slot (not shown) and a cylindrical portion 110 is proximate the protrusion 107 and the slot.

[0017] The second portion 112 includes a plate portion 113 with an aperture 115 proximate the center and sides 116 extending approximately perpendicularly outward from the edges of the plate portion 113. A cover 114, which could be a product label including a variety of information, is configured and arranged to be operatively connected to the plate portion 113 and cover the aperture 115. The top right and left corners and the center of the bottom include receiving members 117 that are configured and arranged to receive the protrusions 107 from the first portion 102, and the hook-like portions proximate the distal ends of the protrusions 107 engage the receiving members 117 proximate the plate portion 113. As shown in Figure 1, proximate one side of the receiving member 117 located proximate the center of the bottom, the side 116 includes a slot 116a and a cylindrical portion 120 is proximate the receiving member 117 and the slot 116a. The inner surface of the plate portion 113 includes cylindrical portions 118 proximate the top of the aperture 115 and flanges 119 proximate the sides of the aperture 115. Although not shown, the first portion 102 includes similar cylindrical portions and flanges. The cylindrical portion 120 corresponds with the cylindrical portion of the first portion 102, and each end of a roller 122 is received by these cylindrical portions.

[0018] A bracket 124 is generally upside down U-shaped and includes top 131 interconnecting a first side 125 and a second side 128. It is recognized that any suitable

bracket member could be used. The first side 125 includes an aperture 127 proximate the center and apertures 126 positioned above the aperture 127. The second side 128 includes an aperture 130 proximate the center and apertures 129 positioned above the aperture 130. The apertures 127 and 130 correspond, and the apertures 126 and 129 correspond. The top 131 includes an aperture 132 proximate the center. Proximate the juncture of the first side 125 and the top 131, two generally parallel slots are cut that extend from the first side 125 to the top 131 and the portion between the two slots is bent inward to form a stop member 133. The stop member 133 preferably forms a generally ninety degree angle. Because both ends of the stop member 133 remain connected to the bracket 124, the stop member 133 is much stronger than if it were formed by a U-shaped slot or cut only connected at one end. Thus, the stop member 133 is reinforced and is less likely to distort when it is engaged by one of the pawls. It is recognized that the stop member could also be a separate piece of material operatively connected to the bracket 124.

[0019] An anchor member 136 generally forms two ring portions with a first aperture 137, which is larger, proximate the top and a second aperture 138, which is smaller, proximate the bottom. A connector 140 is configured and arranged to extend through the aperture 132 in the top 131 of the bracket 124 and connect the anchor member 136 to the bracket 124. The connector 140 is generally U-shaped and includes a bottom portion 145 interconnecting a first side 141 and a second side 143. The first side 141 includes an aperture 142 proximate its distal end, and the second side 143 includes a corresponding aperture 144 proximate its distal end. The bottom portion 145 is generally disk shaped. A washer 146 is preferably positioned between the bottom portion 145 and the bracket 124, and the first and second sides 141 and 143 extend through the aperture 132 of the bracket's top 131. The bottom portion of the anchor member 136 is positioned between the first and second sides 141 and 143 so that the aperture 138 aligns with the apertures 142 and 144, and a fastener 147 extends through the apertures 142, 138, and 144. The anchor member 136 extends outwardly from the top of the housing 101, and the first aperture 137 enables the self-retracting lifeline 100 to be connected to a support structure (not shown) by a hook (not shown) or other suitable fastener well known in the art.

[0020] A drum 150, which resembles a spool when assembled, includes a base 151 and plate members that are a first side 152 and a second side 153 operatively connected to

opposing sides of the base 151. Preferably, the second side 153 is integral with the base 151, as shown in Figure 1, but it is recognized that the second side 153 could be a separate component similar to the first side 152. The base 151 includes a cylindrical portion 150c extending outward therefrom with a bore 150b and preferably four smaller bores 150a positioned about the cylindrical portion 150c extending longitudinally through the base 151 and the second side 153 proximate the center. The first side 152 includes an aperture 152b configured and arranged to receive the cylindrical portion 150c and four apertures 152a corresponding with the bores 150a. A biasing member 159, such as a motor spring, includes an inner end 159a and an outer end 159b. A housing 159c is configured and arranged to receive the biasing member 159 proximate one side of the biasing member 159. The housing 159c generally includes a circular plate member with a side extending outward therefrom to form a cavity in which the biasing member 159 is received. The side includes a slot through which the outer end 159b extends. The inner end 159a is operatively connected to the second side 153 by means well known in the art and the housing 159c is operatively connected to the bracket 124 by a rivet 134 or other means well known in the art. Because the outer end 159b is operatively connected to the housing 159c, which is operatively connected to the bracket 124, the outer end 159b is operatively connected to the bracket 124 and is held in a generally stationary position relative to the bracket 124.

[0021] A lifeline 155 includes a first end, a second end, and an intermediate portion therebetween. Although the preferred embodiment utilizes webbing, it is recognized that cable, rope, or another suitable elongate member may be used as the lifeline. The first end of the lifeline 155 is fixedly operatively connected by means well known in the art to the base 151. The intermediate portion is wound onto and off of the base 151 of the drum 150, and the sides 152 and 153 of the drum 150 keep the lifeline on the base 151. The second end of the lifeline 155 extends through the housing 101 and is operatively connected to a fastening device such as a snap hook 157. The lifeline 155 could also include a shock absorber 156 proximate the snap hook 157.

[0022] A centrifugal brake assembly includes a rotor 162, pawls 172 and 176, and springs 180 and 181. The rotor 162 is generally an oval-shaped disk or plate including two opposing receiving portions. The first receiving portion 165 includes a notched portion 166, which includes a semi-circular portion, and a slotted portion 167. The second receiving portion 168

includes a notched portion 169, which includes a semi-circular portion, and a slotted portion 170. An aperture 163 proximate the center of the rotor 162 is in alignment with aperture 152b of the first side 152 and is also configured and arranged to receive the cylindrical portion 150c. Apertures 164 are arranged about aperture 163 in alignment with apertures 152a and bores 150a. The aperture 163 and the apertures 164 are arranged in a central, generally circular portion of the rotor 162. The receiving portions 165 and 168 extend outward from the central portion of the rotor 162 to form the generally oval-shaped disk.

[0023] The first pawl 172 includes a circular portion 173, a protrusion 174, and a triangular protrusion 175a all protruding outwardly from a generally rectangular base portion 172a. The circular portion 173 protrudes outwardly proximate a first corner of the base portion 172a. The protrusion 174 protrudes outwardly proximate a middle of one side proximate the circular portion 173. A notched portion 175 is formed by the base portion 172a and the triangular protrusion 175a, which extends outwardly proximate a second corner adjacent the circular portion 173 and proximate a side opposite the protrusion 174.

[0024] The first receiving portion 165 of the rotor 162 is configured and arranged to receive the first pawl 172 and a first spring 180. The notched portion 166 receives the circular portion 173 and the slotted portion 167 receives the first spring 180 and the protrusion 174. The notched portion 166 is configured and arranged to allow the first pawl 172 to pivot about the circular portion 173. It is recognized that the slotted portion of the rotor and the protrusion of the pawl could be reversed so that the pawl includes a slotted portion configured and arranged to receive the first spring and the protrusion of the rotor.

[0025] The second pawl 176 includes a circular portion 177, a protrusion 178, and a triangular protrusion 179a all protruding outwardly from a generally rectangular base portion 176a. The circular portion 177 protrudes outwardly proximate a first corner of the base portion 176a. The protrusion 178 protrudes outwardly proximate a middle of one side proximate the circular portion 177. A notched portion 179 is formed by the base portion 176a and the triangular protrusion 179a, which extends outwardly proximate a second corner adjacent the circular portion 177 and proximate a side opposite the protrusion 178.

[0026] The second receiving portion 168 of the rotor 162 is configured and arranged to receive the second pawl 176 and a second spring 181. The notched portion 169 receives the circular portion 177 and the slotted portion 170 receives the second spring 181 and the

protrusion 178. The notched portion 169 is configured and arranged to allow the second pawl 176 to pivot about the circular portion 177. It is recognized that the slotted portion of the rotor and the protrusion of the pawl could be reversed so that the pawl includes a slotted portion configured and arranged to receive the first spring and the protrusion of the rotor.

[0027] To assemble the self-retracting lifeline, the lifeline 155 is operatively connected to the base 151 of the drum and the aperture 152b of the first side 152 receives the cylindrical portion 150c. The apertures 152a of the first side 152 correspond with the bores 150a of the drum 150. The rotor 162 includes the aperture 163 configured and arranged to receive the cylindrical portion 150c and four apertures 164 corresponding with apertures 152a and bores 150a. The bores 150a, the apertures 152a, and the apertures 164 are spaced approximately evenly about the bore 150b of the drum 150, the aperture 152b of the rotor 162, and the aperture 163 of the rotor, respectively, and are configured and arranged to receive fasteners 154. The pawls 172 and 176 and the springs 180 and 181 are positioned in the respective receiving portions 165 and 168. The drum 150, the lifeline 155, the motor spring 159, and the centrifugal brake assembly are configured and arranged to fit between the first and second sides 125 and 128 of the bracket 124 so that the bore 150b corresponds with the apertures 127 and 130. The anchor member 136 is operatively connected to the bracket 124 as previously described. The pawls 172 and 176 are positioned proximate the first side 125. An axel 184 is inserted through the aperture 127, the bore 150b, and the aperture 130 to connect these components.

[0028] The bracket 124 along with the components therein and the roller 122 are then positioned between the first portion 102 and the second portion 112 of the housing 101. The apertures 126 of the first side 125 are configured and arranged to receive the cylindrical portions (not shown) of the first portion 102, and the apertures 129 of the second side 128 are configured and arranged to receive the cylindrical portions 118 of the second portion 112. The receiving members 117 of the second portion 112 receive the protrusions 107 of the first portion 102, and the hook-line portions at the distal ends of the protrusions 107 engage the receiving members 117 to operatively connect the first and second portions 102 and 112 of the housing 101. The apertures 127 and 130 of the bracket's first and second sides 125 and 128 and the bore 150b of the drum 150 align with the apertures 105 and 115 of the housing's first and second portions 102 and 112, and an axel 184 is configured and arranged to extend

therethrough so that the drum 150 is rotatably operatively connected to the bracket 124 and the housing 101. The motor spring 159, which is operatively connected to the drum 150 and the bracket member 124 as previously described, places a biasing force on the drum 150 so that the lifeline 155 is wound about the drum 150 when tension on the lifeline 155 is released. The lifeline 155 extends through the slots in the first and second portions 102 and 112 and the roller 122 assists in reducing wear on the lifeline 155 as it is paid out of and retracted into the housing 101.

[0029] The pawls 172 and 176 and the springs 180 and 181 are held into place by the first side 152 of the drum 150, the rotor 162, and the first side 125 of the bracket 124. In other words, the notched portions 166 and 169, the slotted portions 167 and 170, the first side 152 of the drum 150, and the first side 125 of the bracket 124 form cavities or areas of confinement within which the pawls 172 and 176 and the springs 180 and 181 are arranged.

[0030] In operation, the housing 101 of the self-retracting lifeline 100 is operatively connected to a support structure via the anchor member 136, and the lifeline 155 is operatively connected to a safety harness worn by a worker via the snap hook 157. The worker is free to move about the vicinity of the self-retracting lifeline 100, with only the length of the lifeline 155 restricting the distance of the worker's movement. As the worker moves further away from the self-retracting lifeline 100, lifeline 155 is paid out of the housing 101 as it is unwound from the drum 150. As the worker moves closer to the self-retracting lifeline 100, lifeline 155 is retracted into the housing 101 as it is wound about the drum 150 due to the biasing force exerted upon the drum 150 by the motor spring 159.

[0031] In the event a fall should occur, the sudden acceleration or high rate of speed at which the drum 150 turns to pay out lifeline 155 causes the pawls 172 and 176 to overcome the force of the springs 180 and 181. The centrifugal force causes the pawls 172 and 176 to pivot about the circular portions 173 and 177 and the protrusions 174 and 178 compress the springs 180 and 181. As the drum 150 rotates and the pawls 172 and 176 move from a disengaged position 190 into an engaged position 191, one of the pawls 172 and 176 will engage the stop member 133 of the bracket 124. The notched portions 175 and 179 of the pawls 172 and 176 are configured and arranged to engage the stop member 133. In addition, the protrusions 174 and 178 are positioned within the slotted portions 167 and 170 and the bases 172a and 176a of the pawls 172 and 176 contact the rotor 162, which strengthens the pawl that engages the stop

member 133. The first and second pawls 172 and 176 are each shown in a disengaged position 190 in Figure 2, and the second pawl 176 is shown in an engaged position 191 in Figure 3. When the lifeline 155 unwinds from the drum 150 at a rotational velocity greater than a predetermined maximum rotational velocity, both pawls 172 and 176 pivot to the engaged positions. After the fall is arrested, the pawl that is not engaging the stop member 133 will return to the disengaged position due to the biasing force of the biasing member 159. Engagement of the stop member 133 by one of the pawls 172 and 176 stops rotation of the drum 150 and thus stops additional lifeline 155 from being paid out of the housing 101. Once one of the pawls 172 and 176 has engaged the stop member 133, it cannot be disengaged until the drum 150 begins to rotate backward to rewind the lifeline 155 onto the drum 150. The shock absorber 156 is used to absorb energy and reduce the amount of force exerted upon the worker from the fall.

[0032] During use, but not during a fall, the first spring 180 places a biasing force on the first pawl 172 so that the triangular protrusion 175a contacts the rotor 162 and the second spring 181 places a biasing force on the second pawl 176 so that the triangular protrusion 179a contacts the rotor 162. During a fall or when the drum 150 rotates at a predetermined speed, the biasing forces of the first and second springs 180 and 181 are overcome, the first and second pawls 172 and 176 pivot toward the respective slotted portions 167 and 170, and the protrusions 174 and 178 compress the respective first and second springs 180 and 181.

[0033] One of the advantages of the present invention is the ease of manufacture and assembly of the self-retracting lifeline 100. In prior art self-retracting lifelines, the pawls include pins about which the pawls pivot and the pawls are fixedly attached to the springs, which are fixedly attached to another component. The present invention does not include pins on the pawls or fixedly attach the springs to any component. The pawls 172 and 176 and the springs 180 and 181 are simply placed within the appropriate spaces or cavities formed by the first side 152 of the drum 150, the rotor 162, and the first side 125 of the bracket 124.

[0034] The first side 152 of the drum 150, the rotor 162, and the first side 125 of the bracket 124 form an enclosure that defines boundaries of a confinement cavity, wherein the pawls 172 and 176 and the springs 180 and 181 are held in place from movement in a first direction by a front stop (first side 125) and a back stop (first side 152). The pawls 172 and 176 are held in place from movement in a second direction generally perpendicular to the first

direction by the rotor 162. The springs 180 and 181 are held in place from movement in the second direction by the rotor 162 and the respective protrusions 174 and 178 of the pawls 172 and 176. The pawls 172 and 176 and the springs 180 and 181 are held in place by the boundaries of the confinement cavity. Therefore, the pawls 172 and 176 and the springs 180 and 181 do not require any interconnections such as pins or other fixed attachments well known in the art.

[0035] Figure 4 shows the self-retracting lifeline 100 operatively connected to a harness by means well known in the art.

[0036] It is recognized that the centrifugal brake assembly, including the rotor 162, the pawls 172 and 176, and the springs 180 and 181, of the present invention is not limited to use with the preferred embodiment self-retracting lifeline 100 and may be used with any other suitable self-retracting lifeline or controlled descent device well known in the art.

[0037] The above specification, examples, and data provide a complete description of the manufacture and use of the composition of embodiments of the invention. Although specific embodiments have been illustrated and described herein, it will be appreciated by those of ordinary skill in the art that any arrangement, which is calculated to achieve the same purpose, may be substituted for the specific embodiment shown. This application is intended to cover any adaptations or variations of the invention. Therefore, it is manifestly intended that this invention be limited only by the claims and the equivalents thereof.

CLAIMS:

1. A centrifugal brake assembly, comprising:
 - at least one pawl including a base from which a circular portion and a triangular protrusion extend;
 - at least one biasing member;
 - a rotor including at least one receiving portion having a notched portion being configured and arranged to receive the circular portion;
 - one of the at least one pawl and the rotor having a slotted portion, another of the at least one pawl and the rotor having a protrusion, the slotted portion being configured and arranged to receive the protrusion and the at least one biasing member, the protrusion and the at least one biasing member extending generally in line with one another within the slotted portion; and
 - wherein the at least one pawl is pivotable about the circular portion relative to the rotor and the triangular protrusion of the at least one pawl is configured and arranged to engage a stop member when the at least one pawl is in an engaged position, the base contacting the rotor in the engaged position to reinforce the at least one pawl.
2. The centrifugal brake assembly of claim 1, wherein the at least one biasing member biases the at least one pawl in a disengaged position and the at least one pawl compresses the at least one biasing member and moves into the engaged position when the rotor exceeds a predetermined maximum rotational velocity.
3. The centrifugal brake assembly of claim 1, wherein the at least one pawl includes the protrusion and the rotor includes the slotted portion.
4. A centrifugal brake assembly, comprising:
 - at least one pawl including a base from which a circular portion and a triangular protrusion extend;

at least one biasing member;

a rotor including at least one receiving portion having a notched portion being configured and arranged to receive the circular portion;

one of the at least one pawl and the rotor having a curved slotted portion, said biasing member seated within the slotted portion, another of the at least one pawl and the rotor having a curved elongated protrusion extending in line with the curved slotted portion and the biasing member, the slotted portion being configured and arranged to receive the protrusion and the at least one biasing member, the slotted portion and the protrusion each being separate from the respective notched portion or circular portion; and

wherein the at least one pawl is pivotable about the circular portion relative to the rotor and the triangular protrusion of the at least one pawl is configured and arranged to engage a stop member when the at least one pawl is in an engaged position, the base contacting the rotor in the engaged position to reinforce the at least one pawl.

5. The centrifugal brake assembly of claim 4, wherein the at least one biasing member biases the at least one pawl in a disengaged position and the at least one pawl compresses the at least one biasing member and moves into the engaged position when the rotor exceeds a predetermined maximum rotational velocity.

6. The centrifugal brake assembly of claim 4, wherein the at least one pawl includes the protrusion and the rotor includes the slotted portion, the protrusion being separate from the circular portion, the slotted portion being separate from the notched portion.

7. The centrifugal brake assembly of claim 4, wherein the base of the at least one pawl is generally rectangular, the circular portion protrudes outwardly proximate a first corner of the base portion, and the triangular portion extends outwardly proximate a second corner adjacent the circular portion.

8. The centrifugal brake assembly of claim 4, wherein the notched portion of the rotor includes a semi-circular portion.

9. The centrifugal brake assembly of claim 4, wherein the rotor includes opposing first and second receiving portions and each of the first and second receiving portions is configured and arranged to receive the circular portion of a respective pawl.

10. The centrifugal brake assembly of claim 4, wherein the at least one pawl includes the protrusion and the circular portion, the protrusion, and the triangular protrusion all protrude outwardly from the base, which is generally rectangular shape, the circular portion protruding outwardly proximate a first corner of the base portion, the protrusion protruding outwardly proximate a middle of one side proximate the circular portion, a notched portion formed by the base portion and the triangular protrusion extending outwardly proximate a second corner adjacent the circular portion and proximate a side opposite the protrusion.

11. A centrifugal brake assembly, comprising:

a first pawl including a first base from which a first circular portion, a first triangular protrusion, and a first protrusion extend, the first circular portion, the first triangular protrusion, and the first protrusion extending separately from the first base;

a second pawl including a second base from which a second circular portion, a second triangular protrusion, and a second protrusion extend, the second circular portion, the second triangular protrusion, and the second protrusion extending separately from the second base;

a first biasing member;

a second biasing member;

a rotor including a first receiving portion and a second receiving portion, the first receiving portion having a first notched portion configured and arranged to receive the first circular portion and a first curved slotted portion configured and arranged to receive the first protrusion and the first biasing member, the second receiving portion having a second notched portion configured and arranged to receive the second circular portion and a second

curved slotted portion configured and arranged to receive the second protrusion and the second biasing member;

the first and second biasing members seated within a respective of the slotted portions;

each of the first and second protrusions comprises a curved elongated member extending in line with the curved slotted portion and the biasing member; and

wherein each of the first and second pawls is pivotable about its circular portion relative to the rotor and its triangular protrusion forms a notched pawl portion configured and arranged to engage a stop member when the pawl is in an engaged position, an opposing side of the base from the triangular protrusion contacting the rotor in the engaged position to reinforce the pawl.

12. The centrifugal brake assembly of claim 11, wherein the first and second biasing members bias the respective first and second pawls in a disengaged position and at least one of the first and second pawls compresses the respective biasing member and moves into the engaged position when the rotor exceeds a predetermined maximum rotational velocity.

13. The centrifugal brake assembly of claim 11, wherein the base of the at least one pawl is generally rectangular, the circular portion protrudes outwardly proximate a first corner of the base portion, and the triangular portion extends outwardly proximate a second corner adjacent the circular portion.

14. The centrifugal brake assembly of claim 11, wherein the notched portion of the rotor includes a semi-circular portion.

15. A centrifugal brake assembly, comprising:

at least one pawl including a base from which a pivoting portion and an engaging portion extend;

at least one biasing member;

a rotor including at least one receiving portion configured and arranged to receive the pivoting portion;

one of the at least one pawl and the rotor having a curved slotted portion, another of the at least one pawl and the rotor having a protrusion, the slotted portion being configured and arranged to receive the protrusion and the at least one biasing member; said biasing member seated within the slotted portion;

said protrusion comprises a curved elongated member extending generally in line with the curved slotted portion and the biasing member, the slotted portion and the protrusion each being separate from a respective notched portion or circular portion, the at least one biasing member being positioned between a surface forming an end of the slotted portion and the protrusion and placing a biasing force on the protrusion to position the at least one pawl in a disengaged position, the biasing member being compressible to position the at least one pawl in an engaged position; and

wherein the at least one pawl is pivotable about the pivoting portion relative to the rotor and the engaging portion of the at least one pawl is configured and arranged to engage a stop member when the at least one pawl is in an engaged position, the base contacting the rotor in the engaged position to reinforce the at least one pawl.

16. The centrifugal brake assembly of claim 15, wherein the at least one receiving portion includes a notched portion configured and arranged to receive the pivoting portion, the pivoting portion is generally circular in shape, the engaging portion is generally triangular in shape, and the notched portion includes a generally semi-circular portion.

17. The centrifugal brake assembly of claim 16, wherein the base of the at least one pawl is generally rectangular, the pivoting portion protrudes outwardly proximate a first corner of the base portion, and the engaging portion extends outwardly proximate a second corner adjacent the pivoting portion.

18. The centrifugal brake assembly of claim 15, wherein the at least one pawl includes the protrusion and the rotor includes the slotted portion, the protrusion being separate from the circular portion, the slotted portion being separate from the notched portion.

19. The centrifugal brake assembly of claim 15, wherein the rotor includes opposing first and second receiving portions and each of the first and second receiving portions is configured and arranged to receive the pivoting portion of a respective pawl.

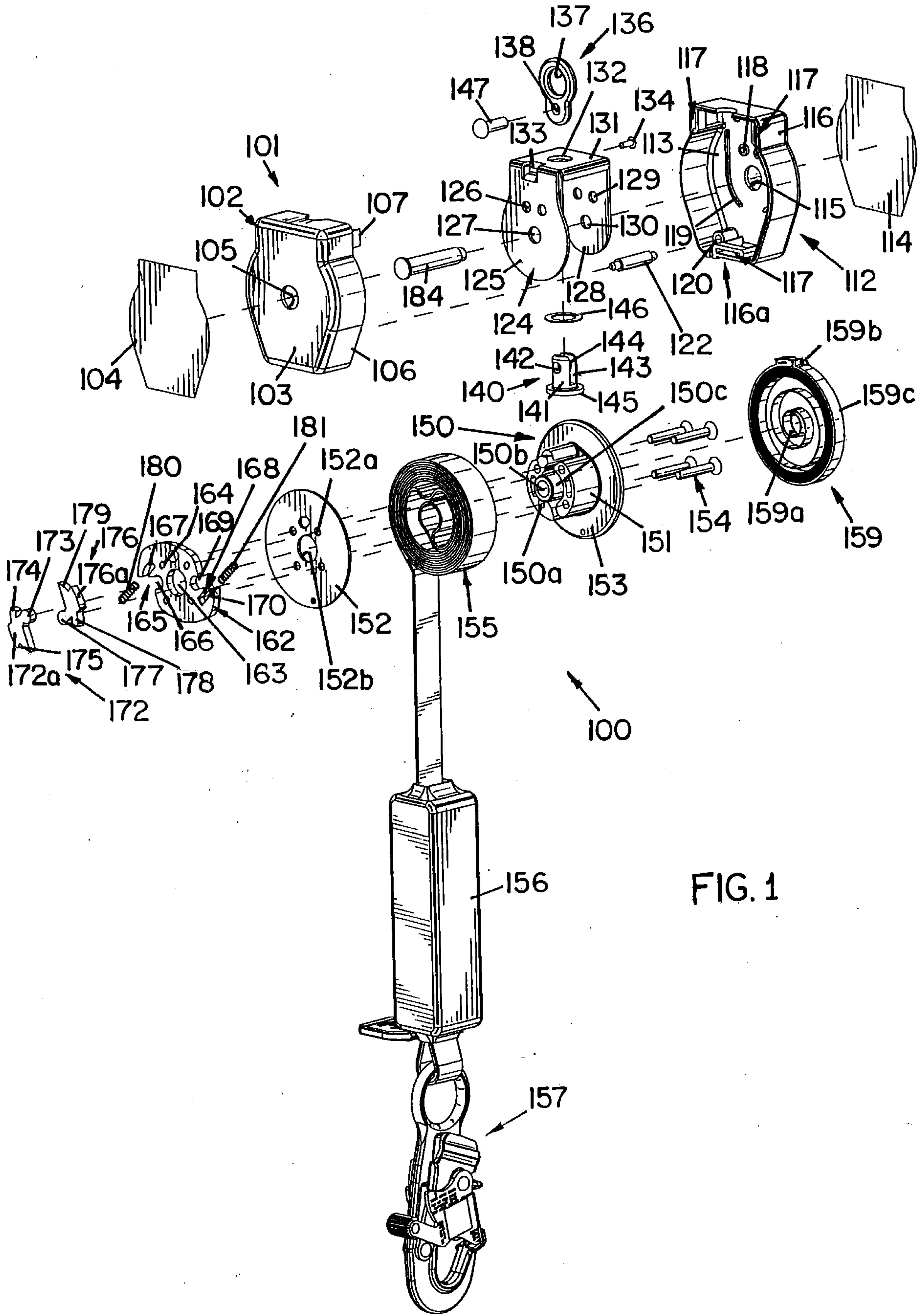

FIG. 1

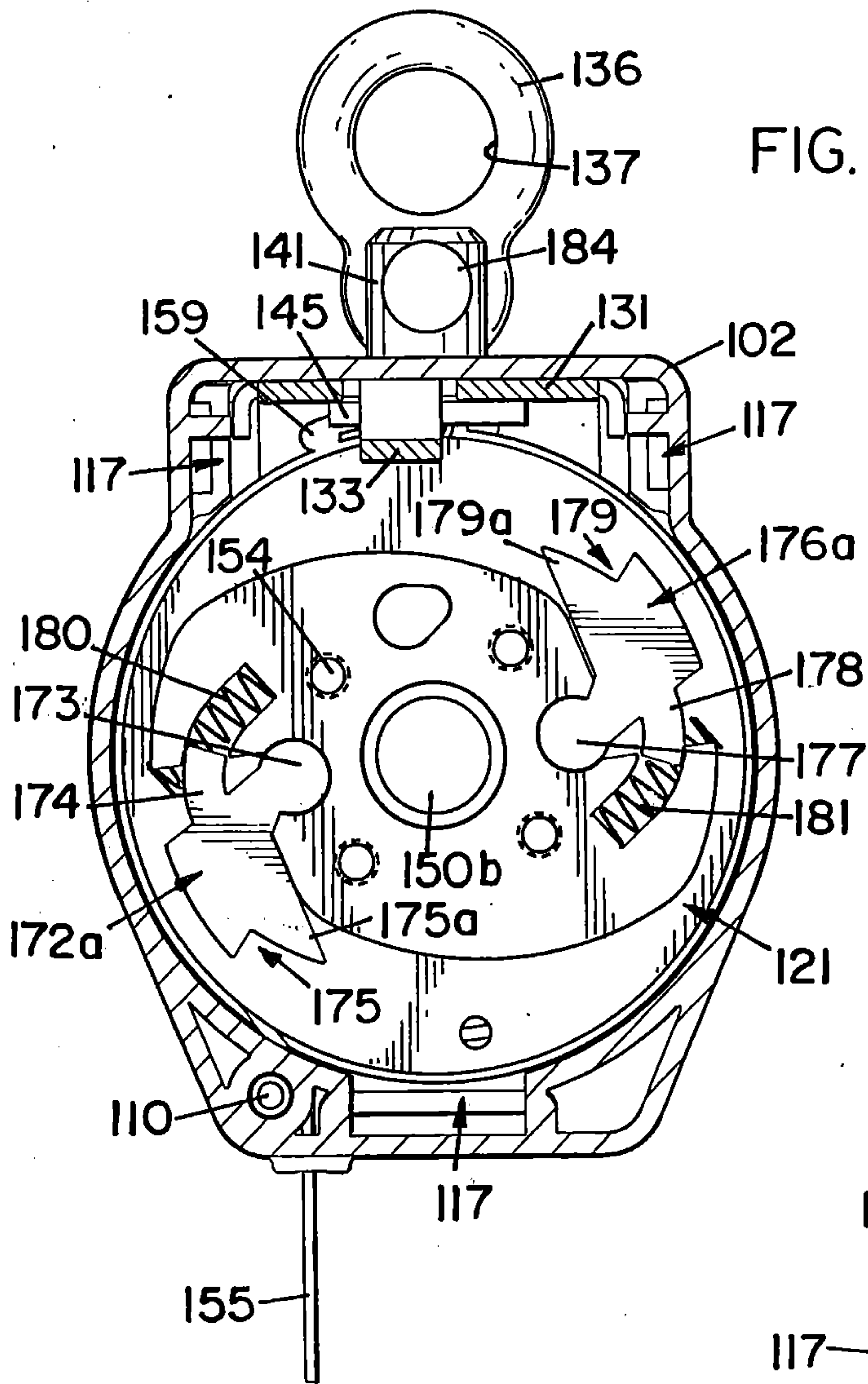

FIG. 2

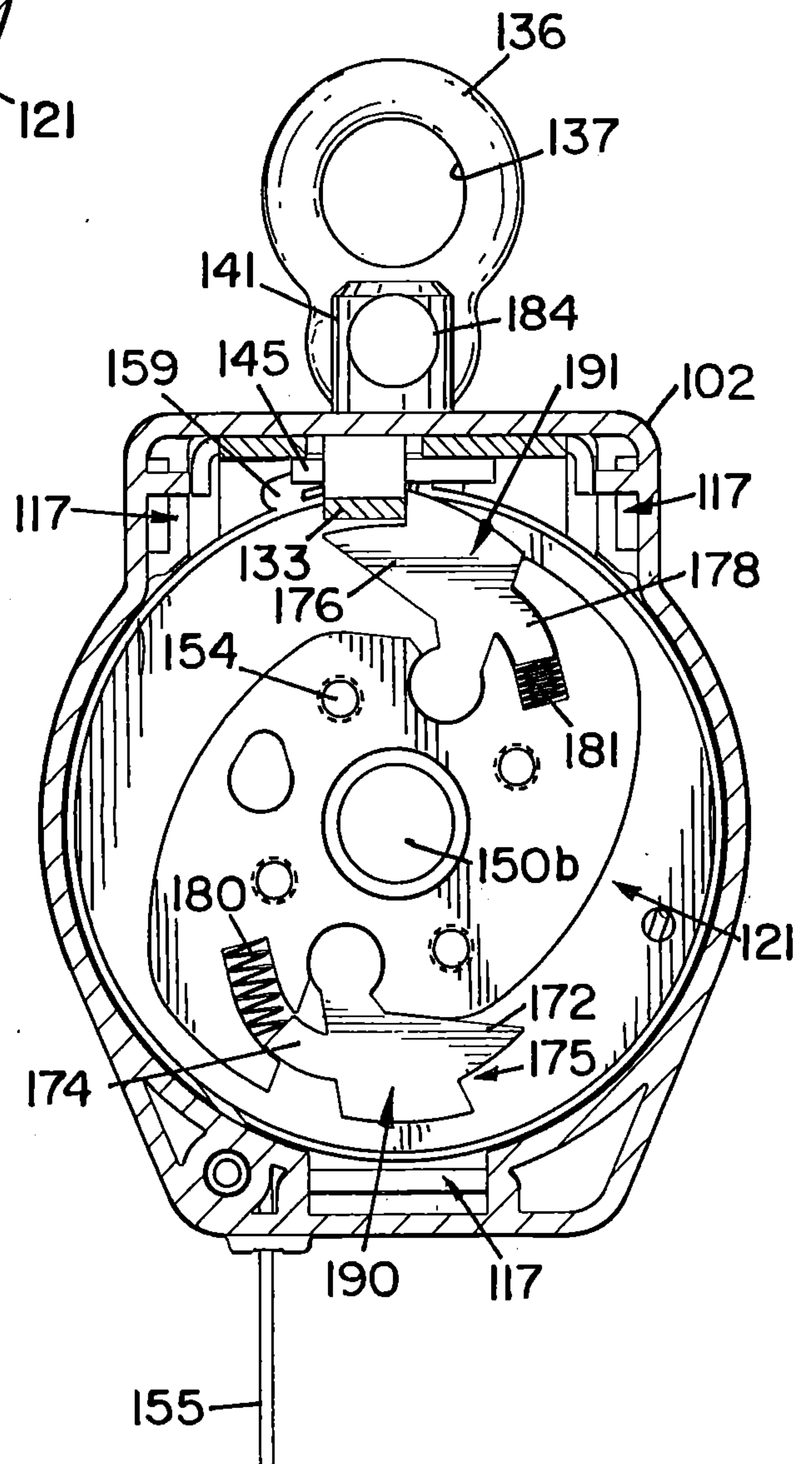

FIG. 3

