



US007182919B2

(12) **United States Patent**
Jackson

(10) **Patent No.:** **US 7,182,919 B2**

(45) **Date of Patent:** ***Feb. 27, 2007**

(54) **SULPHUROUS ACID GENERATOR WITH AIR INJECTOR**

(76) Inventor: **Edward Jackson**, 3167 S. 2900 East, Salt Lake City, UT (US) 84109

(*) Notice: Subject to any disclaimer, the term of this patent is extended or adjusted under 35 U.S.C. 154(b) by 0 days.

This patent is subject to a terminal disclaimer.

(21) Appl. No.: **10/335,227**

(22) Filed: **Dec. 30, 2002**

(65) **Prior Publication Data**

US 2003/0143127 A1 Jul. 31, 2003

Related U.S. Application Data

(63) Continuation of application No. 09/368,674, filed on Aug. 5, 1999, now Pat. No. 6,500,391, which is a continuation-in-part of application No. 09/131,121, filed on Aug. 7, 1998, now Pat. No. 6,080,368.

(51) **Int. Cl.**
B01J 19/00 (2006.01)
C01B 17/48 (2006.01)

(52) **U.S. Cl.** **422/161; 422/160; 422/169; 422/172; 422/189; 423/521**

(58) **Field of Classification Search** **422/160-161, 422/168-169, 176, 188-189, 194, 207, 224, 422/231; 423/243.01, 243.02, 243.03, 521**
See application file for complete search history.

(56) **References Cited**

U.S. PATENT DOCUMENTS

353,222 A 11/1886 Hughes 422/161

1,865,607 A	7/1932	Allen	422/161
2,807,522 A *	9/1957	Russell	422/62
3,226,201 A	12/1965	Harmon	422/161
3,227,201 A	1/1966	Pokomy	431/264
3,314,766 A	4/1967	Mukherji	422/119
3,337,989 A	8/1967	Harmon	47/58.1 R
3,385,030 A *	5/1968	Letvin	95/216
3,409,409 A	11/1968	Sackett, Sr.	422/62
3,574,562 A *	4/1971	Kawahata	422/170
3,627,134 A	12/1971	Mattson	210/192
3,723,068 A	3/1973	McBroy	422/161
3,907,510 A	9/1975	Collins	422/117
4,039,289 A	8/1977	Collins	422/161
4,526,771 A	7/1985	Forbush et al.	423/543
4,747,970 A	5/1988	McFarland	261/96
4,966,757 A	10/1990	Lewis et al.	422/62

(Continued)

OTHER PUBLICATIONS

G. A. Gain and J. B. Chatelain, "New Low Capacity Sulphur Burner," *Chemical & Metallurgical Engineering*, vol. 46 No. 10, p. 637-39, Oct. 1939.

(Continued)

Primary Examiner—Hien Tran
Assistant Examiner—Jennifer A. Leung
(74) *Attorney, Agent, or Firm*—Todd E. Zenger; Kirton & McConkie

(57) **ABSTRACT**

This invention presents a sulphurous acid generator which employs a combination of novel blending contact and mixing mechanisms which maximize the efficiency and duration of contact between sulphur dioxide gas and water to form sulphurous acid in an open nonpressurized system, without employing a countercurrent absorption tower.

5 Claims, 5 Drawing Sheets

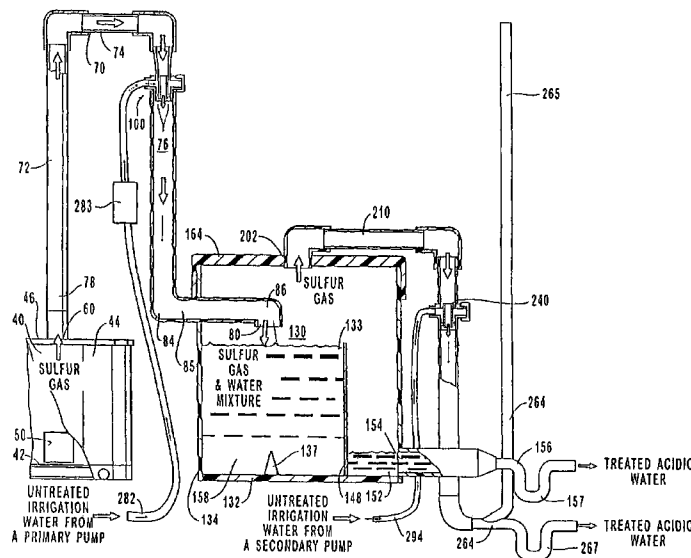

US 7,182,919 B2

Page 2

U.S. PATENT DOCUMENTS

5,032,373 A 7/1991 Jones et al. 423/522
6,080,368 A 6/2000 Jackson 422/161
6,248,299 B1 6/2001 Jackson 422/161
6,500,391 B1 12/2002 Jackson 422/161

6,506,347 B1 * 1/2003 Jackson 422/161

OTHER PUBLICATIONS

Harmon SO₂ Generators: Care and Maintenance, no date.

* cited by examiner

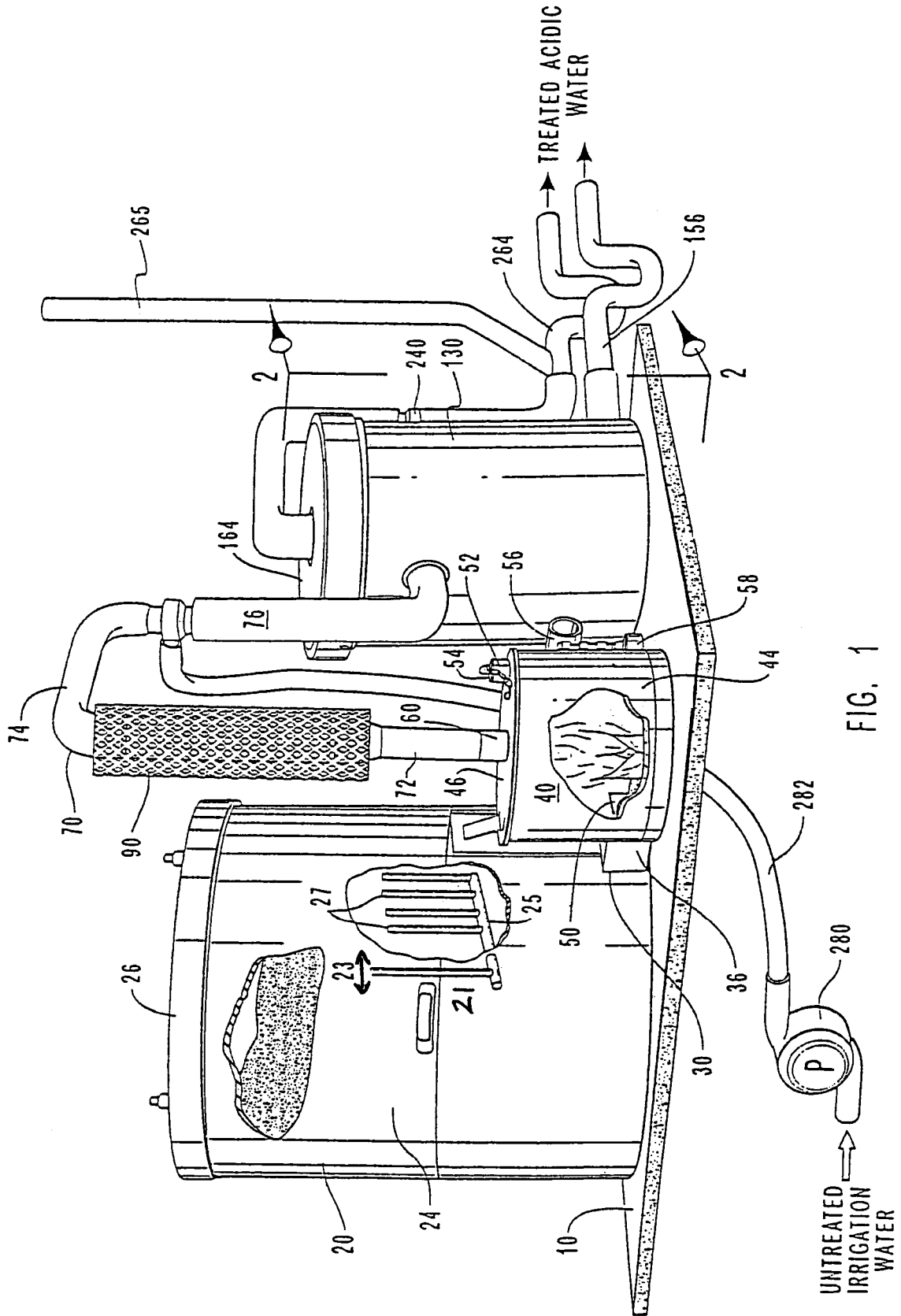

FIG. 1

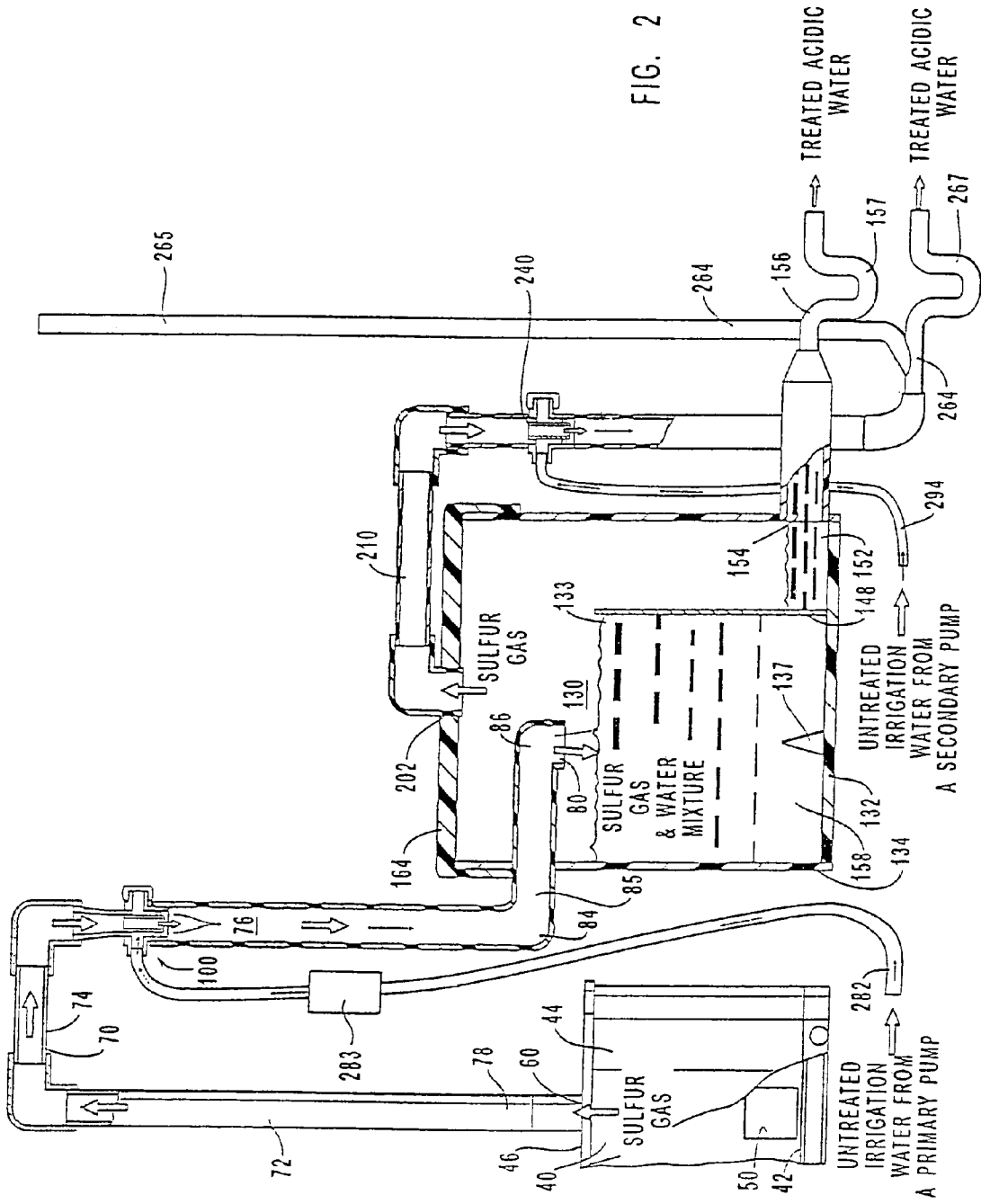

FIG. 2

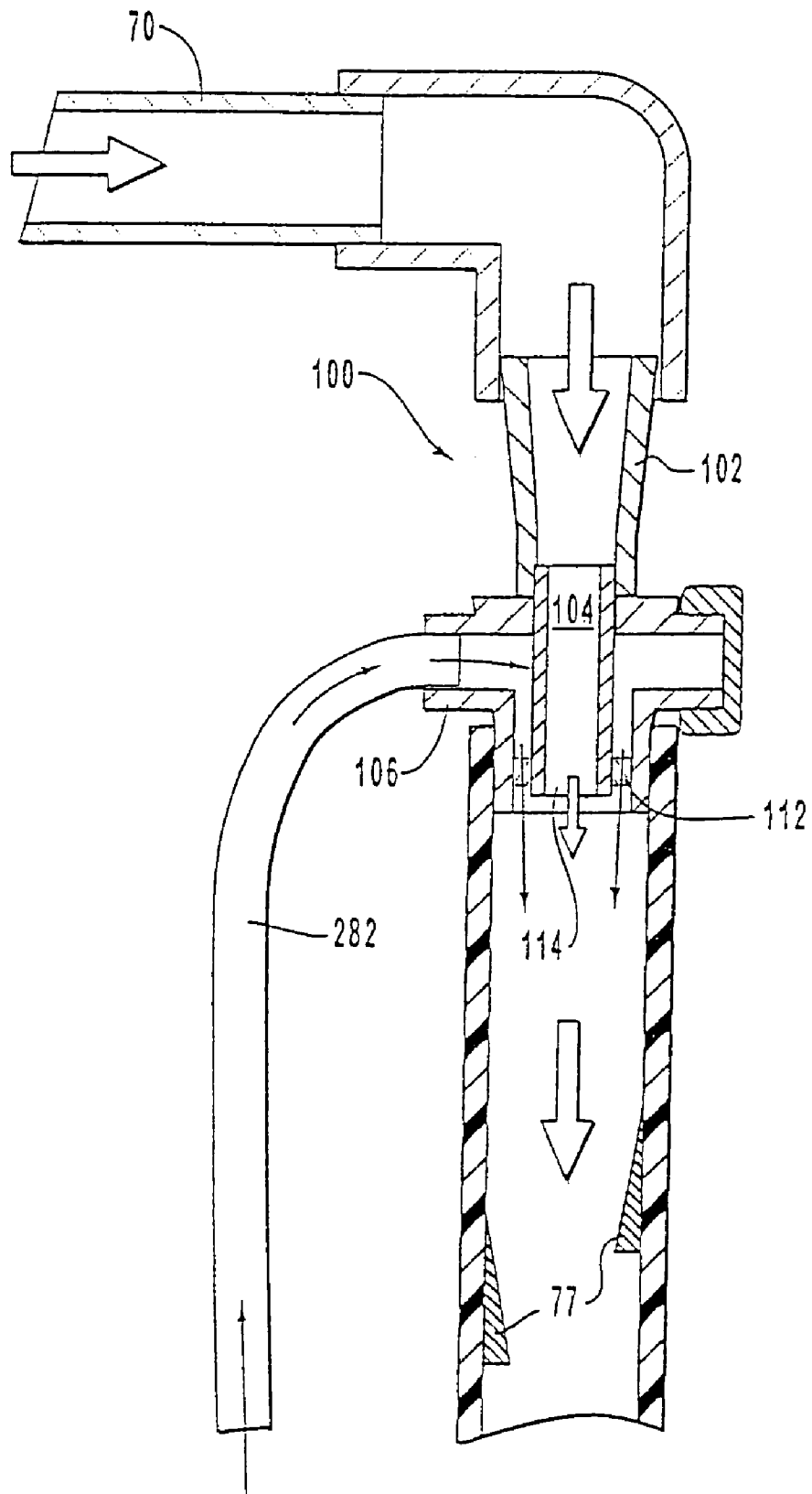

FIG. 3

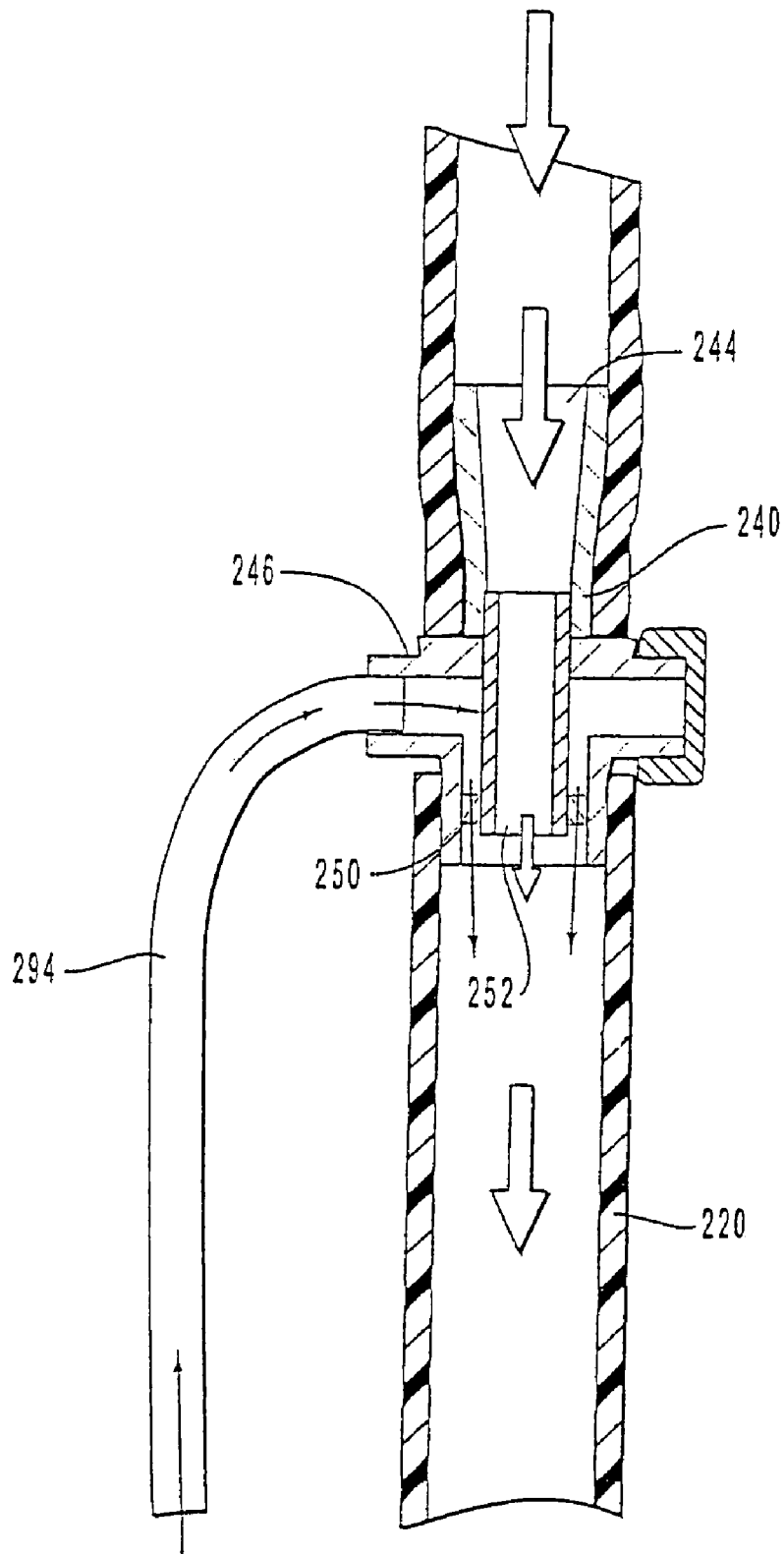

FIG. 4

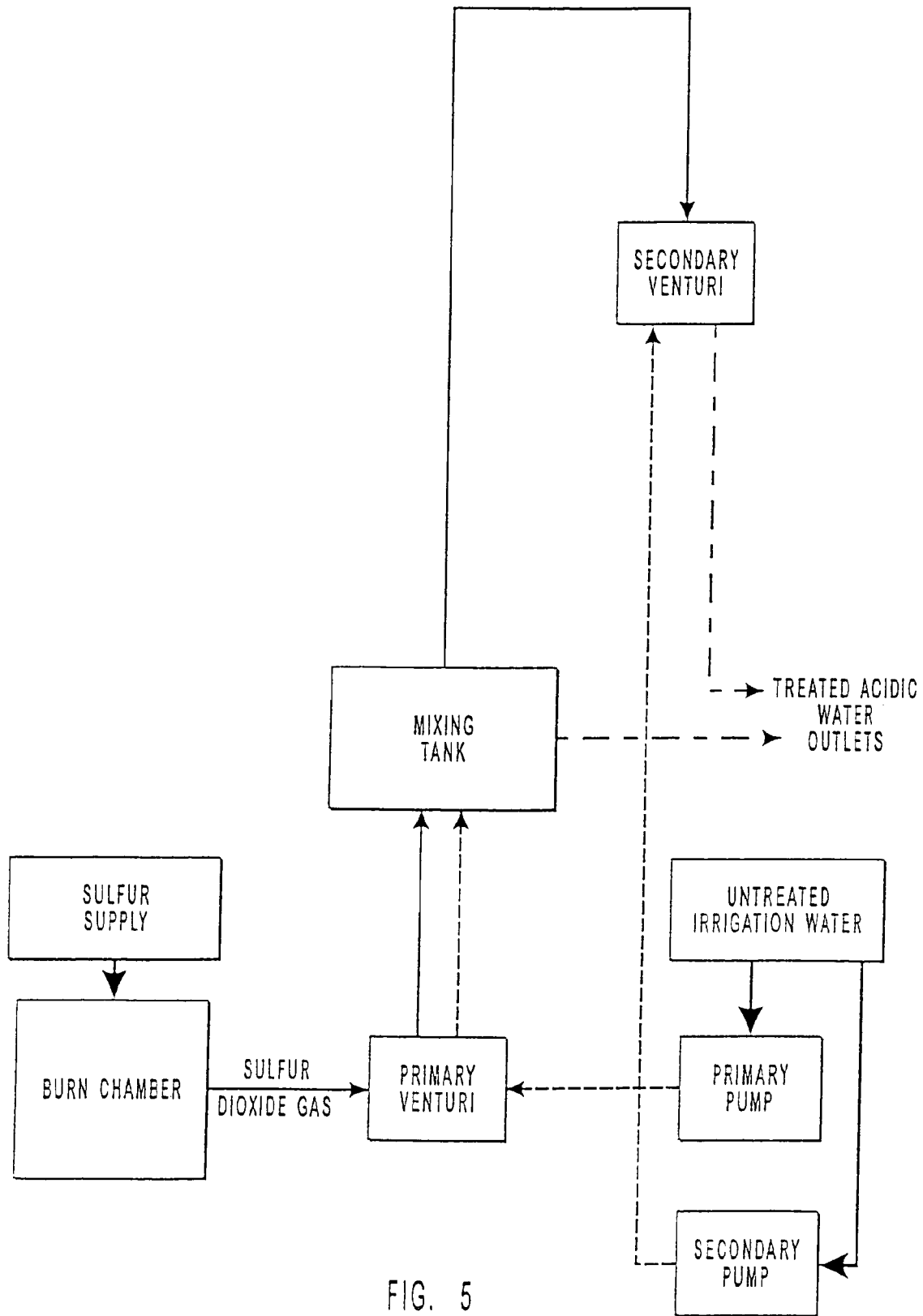

FIG. 5

SULPHUROUS ACID GENERATOR WITH AIR INJECTOR

RELATED APPLICATIONS

This application is a continuation of U.S. patent application Ser. No. 09/368,674, filed Aug. 5, 1999, entitled "Sulphurous Acid Generator with Air Injector," now U.S. Pat. No. 6,500,391, issued Dec. 31, 2002; which is a continuation-in-part application of U.S. patent application Ser. No. 09/131,121, filed Aug. 7, 1998, entitled "Open System and Acid Generator," now U.S. Pat. No. 6,080,368, issued Jun. 27, 2000.

BACKGROUND OF THE INVENTION

The Field of the Invention

Only a fraction of the Earth's total water supply is available and suitable for agriculture, industry and domestic needs. The demand for water is great and new technologies together with growing populations increase the demand for water while pollution diminishes the limited supply of usable water. The growing demand for water requires efficient use of available water resources.

Agricultural use of water places a large demand on the world's water supply. In some communities, the water supply may be adequate for farming but the quality of the water is unsuitable for agriculture because the water is alkaline. Alkalinity is an important factor affecting the quality, efficiency and performance of soil and irrigation water. A relative increase in irrigation alkalinity due to the water's sodium to calcium ratio or a high pH renders irrigation water detrimental to soil, crop growth and irrigation water efficiency. Such water can be reclaimed for soil rehabilitation and irrigation by adding lower pH sulphurous acid to the alkaline water to reduce its alkalinity or pH.

The invention of this application is directed toward a device which generates sulphurous acid in a simplified, efficient way. In particular, it is directed toward a sulphurous acid generator which produces sulphurous acid by burning sulphur to produce sulphur dioxide gas. The sulphur dioxide gas is then drawn toward and held in contact with air-injected water eventually reacting with the water and producing sulphurous acid, while virtually eliminating dangerous emissions of sulphur dioxide gas to the air.

THE RELEVANT TECHNOLOGY

There are several sulphurous acid generators in the art. The prior art devices utilize sulphur burn chambers and absorption towers. However, known systems utilize countercurrent current flow or pressurized systems as the principle means to accomplish the generation of sulphurous acid. For example, many devices employ the absorption tower to introduce the majority of the water to the system in countercurrent flow to the flow of sulphur dioxide gas. U.S. Pat. No. 4,526,771 teaches introducing 90% of the system water for the first time in countercurrent flow at the top of the absorption tower. In such devices, the integrity of the absorption towers is vital, and any deficiencies or inefficiencies of the absorption tower lead to diminished reaction and results. Other devices utilize pressurized gas to facilitate flow of gas through the system, see U.S. Pat. No. 3,226,201. Pressurized devices, however, require expensive manufacture to ensure the containment of dangerous sulphur dioxide gas to avoid leakage. Even negative pressure machines have

the drawback of requiring a source of energy to power the negative pressure generator such as an exhaust fan. Still other devices rely upon secondary combustion chambers to further oxidize the sulphur, see U.S. Pat. No. 4,526,771.

5 Many sulphurous acid generators emit significant or dangerous levels of unreacted sulphur dioxide gas, a harmful and noxious pollutant, into the surrounding environment.

SUMMARY AND OBJECTS OF THE INVENTION

The present invention is directed to a sulphurous acid generator which can be used to improve alkaline irrigation water by adding the sulphurous acid produced by the generator to alkaline water to reduce the alkalinity and/or pH of the water. In addition to making the water less alkaline, adding sulphurous acid to alkaline water increases the availability of sulphur in the water to act as a nutrient, improves capillary action of the soil, increases cation exchange capacity, and decreases tail water run-off and tillage and fertilizer costs.

In many agricultural settings, complicated farm machinery is not practical because it requires technical training to operate and special skills to service and maintain. For sulphur generators, improved design can reduce costs, simplify operation, service and maintenance and increase efficiency and safety thereby making the machine more practical for agricultural use. The present invention is directed toward a sulphurous acid generator that is simple to produce, operate, service and maintain, and which efficiency produces, contains and reacts sulphur dioxide gas and sulphurous acid without exposing the user or other living things in proximity to the machine to dangerous sulphur dioxide emissions.

It will be appreciated that a specific energy source is not necessarily required by the present invention, and therefore its use is not necessarily restricted to locations where a particular power source, like electricity, is available or can be generated for use. All of the above objectives are met by the present invention.

Unlike the prior art, the present invention is designed to maximize the amount of air/oxygen enriched water in contact with sulphur dioxide gas and the duration of the contact of water with sulphur dioxide gas without creating any significant back pressure in the system or relying upon pressurization or elevated temperature of the gas to cause the sulphur dioxide gas to flow through the sulphurous acid generator. This reduces the complexity of the sulphurous acid generator and the need for additional equipment such as air compressors used by prior art devices.

The invention primarily relates to a sulphur hopper, a burn chamber, an air injector, a gas pipeline, a mixing tank, and an exhaust pipeline.

The sulphur hopper preferably has a capacity of several hundred pounds of sulphur in powder or flake form. The sulphur hopper can be constructed of various materials or combinations thereof. In the preferred embodiment, the sulphur hopper is constructed of stainless steel and plastic. The sulphur hopper is connected to the burn chamber by a passageway positioned at the base of the sulphur hopper. The conduit joins the burn chamber at its base. The weight of the sulphur in the sulphur hopper forces sulphur through the passageway at the base and into the burn chamber, providing a continual supply of sulphur for burning. The flow of sulphur may be augmented using an anti-cavitation rake or scraper.

The burn chamber has an ignition inlet on the top of the burn chamber through which the sulphur is ignited and an air inlet on the side of the chamber through which oxygen enters to fuel the burning sulphur. The burning sulphur generates sulphur dioxide gas. In the preferred embodiment, the bottom of the chamber is removable, facilitating access to the chamber for maintenance and service. The burn chamber is constructed of material capable of withstanding the corrosiveness of the sulphur and the heat of combustion, preferably stainless steel.

Sulphur dioxide gas exits the burn chamber through an exhaust outlet on the top of the burn chamber and is drawn into a first conduit. The first conduit may be manufactured from stainless steel.

A supply of water is conducted by a second conduit and may be brought from a water source through the second conduit by any means capable of delivering sufficient water and pressure, such as an elevated water tank or a mechanical or electric pump. Along the length of the second conduit, air with its oxygen component is injected into the ambient water.

The first conduit and second conduit meet and couple with a third conduit. The third conduit comprises a blending portion, a contact containment portion, an agitation portion and a means for discharging the sulphurous acid and unreacted sulphur dioxide gas. In the third conduit, the sulphur dioxide gas and air/oxygen enriched water are brought in contact with each other to form sulphurous acid. The third conduit may be constructed of polyethylene plastic.

The blending portion of the third conduit comprises a means for bringing the sulphur dioxide gas in the first conduit and the water in the second conduit into contained, codirectional flow into contact with each other. The majority of water used to create sulphurous acid in the system and method is introduced into the third conduit and flows through one or more contact containment and agitation portions in the third conduit through the contact means. Thereafter, the water and sulphur dioxide gas flow through one or more contact containments, discharging naturally by gravity into a mixing tank.

Water is introduced into the third conduit in co-directional flow with the sulphur dioxide gas so as to create an annular column of water with the sulphur dioxide gas flowing inside the annular column of water thereby blending the water and sulphur dioxide gas together. In the preferred embodiment, water is introduced into the gas pipeline and passes through an eductor, which causes sulphur dioxide gas to be drawn through the first conduit without the need of pressuring the sulphur dioxide gas and without using an exhaust fan. The water and sulphur dioxide gas remain in contact with each other for the period of time it takes to flow through a portion of the third conduit. In the contact area, a portion of the sulphur dioxide gas reacts with the water, creating sulphurous acid.

The agitation portion comprises a means for mixing and agitating the codirectionally flowing sulphur dioxide gas and water/sulphurous acid. The agitation portions enhance sulphur dioxide gas reaction and dispersion. Bends in the third conduit or obstructions within the third conduit are contemplated as possible means for mixing and agitating in the agitation portion. Agitation of the co-directional flow of the sulphur dioxide gas and water further facilitates reaction of the sulphur dioxide gas with water into a mixing pool. Sulphurous acid and sulphur dioxide gas flow out of the third conduit through means for discharging the sulphurous acid and unreacted sulphur dioxide gas.

A discharge outlet represents a possible embodiment of means for discharging the sulphurous acid and unreacted sulphur dioxide gas. The discharge outlet permits conduit contents to enter a gas submersion zone.

The sulphurous acid and unreacted sulphur dioxide gas exit the third conduit through the discharge and enter a mixing tank. In one embodiment, a weir divides the mixing tank into two sections, namely a pooling section and an effluent or outlet section. Sulphurous acid and sulphur dioxide gas exit the discharge of the third conduit into the pooling section. As the sulphurous acid pours into the mixing tank, it creates a pool of sulphurous acid equal in depth to the height of the weir. At all times, the sulphurous acid and unreacted sulphur dioxide gas discharge from the third conduit above the level of the liquid in the pooling section of the mixing tank.

In other words, the discharge from the third conduit is positioned sufficiently above the surface of the pool, so that sulphur dioxide gas exiting the pipeline can pass directly into and be submerged within the pool while in an open (nonclosed) arrangement. In other words, the discharge from the third conduit does not create any significant back pressure on the flow of sulphurous acid or sulphur dioxide gas in the third conduit or gas pipeline. Nevertheless, the close vertical position of the discharge from the third conduit above the surface of the pool reduces the likelihood that the unreacted sulphur dioxide gas will exit from the discharge without being submerged in the pool. The discharge is removed a distance from the sidewall of the mixing tank toward the center of the pooling section to allow the pool to be efficiently churned by the inflow of sulphurous acid and unreacted sulphur dioxide gas from the third conduit.

As acidic water and gas continue to enter the mixing tank from the third conduit, the level of the pool eventually exceeds the height of the weir. Sulphurous acid spills over the weir and into the effluent or outlet section of the mixing tank where the sulphurous acid exits the mixing tank through an effluent outlet. The top of the effluent outlet is positioned below height of the weir and the discharge from the third conduit in order to reduce the amount of free floating unreacted sulphur dioxide gas exiting the chamber through the effluent outlet. Free floating, unreacted sulphur dioxide gas remaining in the mixing tank rises up to the top of the mixing tank. The top of the mixing tank is adapted with a lid. Under dissolved sulphur dioxide bubbles flowing through the affluent outlet are trapped by a standard u-trap, forcing accumulated bubbles back into the mixing tank while sulfurous acid exits the system through a first discharge pipe.

To ensure further elimination of any significant emissions of sulphur dioxide gas from the generator into the environment, the sulphur dioxide gas remaining in the mixing tank may be drawn into an exhaust conduit coupled with an exhaust vent on the lid of the mixing tank. The exhaust conduit defines a fourth conduit. Positioned in the fourth conduit is a means for introducing water into the fourth conduit. The water which enters the fourth conduit may be brought from a water source by any means capable of delivering sufficient water to the fourth conduit. As the water is introduced into the fourth conduit, it reacts with the sulphur dioxide gas that has migrated out through the lid of the mixing tank of the absorption tower, and creates sulphurous acid.

In the preferred embodiment, water introduced into the fourth conduit, passes through a second eductor causing the sulphur dioxide gas to be drawn through the vent and into the fourth conduit. The gas and water are contained in

5

contact as they move through one or more contact containment and/or agitation portions of the fourth conduit. Sulphurous acid exits the fourth conduit through a second discharge pipe. In a preferred embodiment, the second discharge pipe also comprises a u-trap configuration, upstream from the u-trap, a thin stack permits reactive gases to discharge from the system.

The fourth conduit may be constructed of high density polyethylene plastic. High density polyethylene plastic is preferred for its durability and resistance to ultra violet ray degradation. It is another object of this invention to eliminate the countercurrent absorption powers of the prior art.

As mentioned, the water introduced into the system to the third conduit and fourth conduit may be brought from a water source to the system by any means capable of delivering sufficient water and pressure, such as a standing, elevated water tank, or mechanical, electric or diesel powered water pump.

It is an object of this invention to create a sulfurous acid generator that is simple to manufacture, use, maintain and service.

It is further an object of this invention to create a sulfurous acid generator that is capable of operating without any electrical equipment such as pumps, air compressor or exhaust fans requiring a specific energy source requirement, such as electricity or diesel fuels.

It is also an object of this invention to provide air/oxygen enriched water for reaction with the sulphur dioxide gas.

It is another object of this invention to produce a sulphurous acid generator which converts substantially all sulfur dioxide gas generated into sulphurous acid.

It is another object of the invention to produce a sulfurous acid generator which uses an induced draw created by the flow of water through the system to draw gases through the otherwise open system.

Another object of the present invention is to provide a sulphurous acid generator with one or more contact containment and/or agitation and mixing mechanisms to increase the duration of time during which the sulphur dioxide gas is in contact with and mixed with water.

It is an object of this invention to produce a sulphurous acid generator which substantially eliminates emission of harmful sulphur dioxide gas.

These and other objects and features of the present invention will become more fully apparent from the following description and appended claims, or may be learned by the practice of the invention as set forth hereinafter.

BRIEF DESCRIPTION OF THE DRAWINGS

In order that the manner in which the above-recited and other advantages and objects of the invention are obtained, a more particular description of the invention briefly depicted above will be rendered by reference to a specific embodiment thereof which is illustrated in the appended drawings. With the understanding that these drawings depict only a typical embodiment of the invention and are not therefore to be considered to be limiting of its scope, the invention will be described and explained with additional specificity and detail through the use of the accompanying drawings in which:

FIG. 1 is a perspective view of one embodiment of the sulphurous acid generator.

FIG. 2 is a side elevation view partly in cutaway cross-section of the components of the sulphurous acid generator.

FIG. 3 is an enlarged view of a portion of a third conduit.

6

FIG. 4 is an enlarged view of a portion of a fourth conduit. FIG. 5 is a flow chart explaining the inventive process.

DETAILED DESCRIPTION OF THE PREFERRED EMBODIMENTS

Including by reference the figures listed above, applicant's sulfurous acid generator comprises a system which generates sulphur dioxide gas and keeps the gas substantially contained and in contact with water for extended periods of time substantially, eliminating any significant release of harmful sulphur dioxide gas from the system. As shown in FIGS. 1 and 2, the principle elements comprise a sulphur hopper 20, a burn chamber 40, a gas pipeline 70, a mixing tank 130, and an exhaust conduit 210. The principle elements are mounted on a platform 10 to facilitate transport.

The sulphur hopper 20 comprises enclosure 24 with a top surface 26. The top surface 26 defines a closeable aperture, not shown. Enclosure 24 may be of any geometric shape; cylindrical is shown, rectangular may also be employed. Surface 26 of enclosure 24 comprises a closeable aperture of sufficient diameter and shape to allow sulphur to be loaded into the hopper 20. The enclosure 24 defines a hopper outlet 30. The hopper 20 is configured such that sulphur in the hopper 20 is directed toward the hopper outlet 30 by the pull of gravity. The hopper outlet 30 allows sulphur to pass through and out of the hopper 20.

A passageway conduit 36 communicates between the hopper outlet 30 and burn chamber inlet 50 of the burn chamber 40.

In an alternative embodiment, enclosure 24 may include a rocker arm 21 mounted external of enclosure 24. Rocker arm 21 is capable of being moved back and forth as shown by arrow 23. Connected to substantially vertical rocker arm 21, and extending internal to enclosure 24, is bar 25 having substantially upward extending of fingers 27. Fingers 27 extend upward into the sulphur supply such rocker arm 21 can be manipulated back and forth, thereby manipulating or raking fingers 27 back and forth to avert incavitation of sulphur that may occur in hopper 20.

The burn chamber 40 comprises a floor member 42, a chamber sidewall 44 and a roof member 46. The floor member 42 defines a perimeter and the floor member 42 is removably attached to the chamber sidewall 44. The roof member 46 is secured to the chamber sidewall 44, the chamber sidewall 44 supporting the roof member 46. An ignition inlet 52 defined by the roof member 46 has a removably attached ignition inlet cover 54. An air inlet 56 defined by the chamber sidewall 44 has a removably attached air inlet cover 58. The air inlet 56 is positioned substantially opposite to the conduit inlet 50 and may enter the chamber sidewall 44 tangentially. An exhaust opening 60 in the burn chamber 40 is defined by the roof member 46.

Sulphur supplied to the burn chamber 40 through the conduit inlet 50 can be ignited through the ignition inlet 52. The air inlet 56 allows oxygen, necessary for the combustion process, to enter into the burn chamber 40 and thus permits regulation of the rate of combustion. The exhaust opening 60 allows the sulphur dioxide gas to pass up through the exhaust opening 60 and into the gas pipeline 70.

The gas pipeline 70 has two ends, the first end 78 communicating with the exhaust opening 60, the second end terminating at a third conduit 76. The gas pipeline or first conduit 70 may comprise an ascending pipe 72 and a transverse pipe 74. The ascending pipe 72 may communicate with the transverse pipe 74 by means a first 90 degree elbow

joint. Disposed about and secured to the ascending pipe **72** is a protective grate **90** to prevent unintended external contact with member **72** which is hot when in use.

Water is conducted through a second conduit **282** to a point at which the second conduit **282** couples with the first conduit **70** at a third conduit **76**. Along the length of second conduit **282**, an injector **283** disperses additional air into the water. In most applications, and those in which the present invention is used to increase the growth of crops and the like, ambient air has an oxygen component. Air can be injected into the water by creating a differential pressure along the length of the water such that air is drawn into the water. Air injectors are known. The preferred air injector is the Mazzei RTM. Injector from Mazzei Injector Corporation, Bakersfield, Calif., United States of America. Equivalent devices will be known or readily discoverable by those skilled in the art. The air injector entrains additional air in the water stream. Entraining additional air in the water provides a stream of water enriched with air/oxygen. Water enriched with air/oxygen enhances the reaction rate of the water with the sulphur dioxide gas in the generation of intermediary sulphurous anhydride and ultimately of sulphurous acid. The inclusion of an air injector has the advantage of producing results significantly better than the performance of the prior art. Furthermore, like the other components of the present invention, the preferred air injector has no moving parts in operation.

Conduit **76** comprises a means **100** for bringing the sulphur dioxide gas in the first conduit and substantially all the water in second conduit **282** into contained codirectional flow whereby the sulphur dioxide gas and water are brought into contact with each other.

The codirectional flow means **100** shown in FIGS. **2** and **3**, comprises a central body **102**, the central body defining a gas entry **104** and a sulfur dioxide gas exiting outlet **114**, the central body comprising a secondary conduit inlet **106**, a cooling ring outlet **108**, an emitter and an eductor **112**. The eductor **112** generates an annular column of water to encircle gas exiting outlet **114**. The nature of this water flow is believed to assist in drawing sulphur dioxide gas from the burn chamber **40** into the gas pipeline **70** where the gas is brought into contact with water to create sulphurous acid.

The codirection flow means **100** allows water to be introduced into the third conduit **76** initially through a second conduit inlet **106**. The water entering the codirectional means **100** passes through the eductor **112** and, exits adjacent the sulphur dioxide gas outlet **114**. The water enters the third conduit **76** and comes into contact with the sulphur dioxide gas by surrounding the sulphur dioxide gas where the sulphur dioxide gas and water are contained in contact with each other. The water and sulphur dioxide gas react to form an acid of sulphur. This first contact containment portion of conduit **76** does not obstruct the flow of the sulphur dioxide gas. It is believed that a substantial portion of the sulphur dioxide gas will react with the water in this first contact containment area.

After the acid and any host water (hereafter "water/acid") and any remaining unreacted gas continue to flow through third conduit **76**, the water/acid and unreacted sulphur dioxide gas are mixed and agitated to further facilitate reaction of the sulphur dioxide with the water/acid. Means for mixing and agitating the flow of water/acid and sulphur dioxide gas is accomplished in a number of ways. For example, as shown in FIG. **2**, mixing and agitating can be accomplished by changing the direction of the flow such as a bend **84** in the third conduit **76**. Another example includes placing an object **77** inside the third conduit **76** to alter the

flow pattern in the third conduit **76**. This could entail a flow altering wedge, flange, bump or other member along the codirectional flow path in third conduit **76**. By placing an object in the flow path, a straight or substantially straight conduit may be employed. The distinction of this invention over the prior art is mixing and agitating the flow of water/acid and sulphur dioxide involving substantially all of the water of the system with sulphur dioxide gas in an open codirectionally flowing system. One embodiment of the present invention can treat between 50 and 300 gallons of water per minute coursing through third conduit **76** being held in contained contact with the sulphur dioxide gas.

After the water/acid and sulphur dioxide gas have passed through an agitation and mixing portion of third conduit **76**, the water/acid and unreacted sulphur dioxide gas are again contained in contact with each other to further facilitate reaction between the components to create an acid of sulphur. This is accomplished by means for containing the water/acid and sulphur dioxide gas in contact with each other. One embodiment is shown in FIG. **2** as a portion **85** of third conduit **76**. Portion **85** acts much in the same way as the earlier described contact containment portion.

In a preferred embodiment, additional means for mixing and agitating the codirectional flow of water/acid and sulphur dioxide gas is employed. One embodiment is illustrated as portion **86** of third conduit **76** in which again the directional flow of the water/acid and sulphur dioxide gas is directionally altered. In this way, the water/acid and sulphur dioxide gas are forced to mix and agitate, further facilitating reaction of the sulphur dioxide gas to further produce or concentrate an acid of sulphur.

Third conduit **76** also incorporates means for discharging the water/acid and unreacted sulphur dioxide gas before the various third conduit **76**. One embodiment is shown in FIG. **2** as discharge opening **80** defined by third conduit **76**. Discharge opening **80** is preferably positioned approximately in the center of the pooling section, described below. In the preferred embodiment, discharge **80** is configured so as to direct the discharge of water/acid and unreacted sulphur dioxide gas downward into a submersion pool **158** without creating a back pressure. In other words, discharge **80** is sufficiently close to the surface **133** of the fluid in the submersion pool to cause unreacted sulphur dioxide gas to be forced into the submersion pool, but not below the surface of the fluid in the submersion pool, thereby maintaining the open nature of the system and to avoid creating back pressure in the system.

The present invention also utilizes a tank **130** having a bottom **132**, a tank sidewall **134**, and a lid **164**. Tank **130** may also comprise a fluid dispersion member **137** to disperse churning sulphurous acid and sulphur dioxide gas throughout tank **130**. Dispersion member **137** may have a conical shape or any other shape which facilitates dispersion. A weir **148** maybe attached on one side to the bottom member **132** and is attached on two sides to the tank sidewall **134**. The weir **148** extends upwardly to a distance stopping below the discharge **80**. The weir **148** divides the mixing tank **130** into a submersion pool **158** and an outlet section **152**. The third conduit **76** penetrates the tank sidewall **134** at a point below the lid **164**. An outlet aperture **154** is positioned in the tank sidewall **134** near the bottom member **132** in the discharge section. The drainage aperture **154** is connected to a drainage pipe **156**. Drainage pipe **156** is adapted with a u-trap **157**. U-trap **157** acts as means to force levels of gas of undissolved gas for sulphur dioxide gas back into chamber **130** to exit through lid **164** into vent conduit **210**.

As sulphurous acid flows out of the third conduit **76**, the weir **148** dams the acid coming into the mixing tank **130** creating a churning submersion pool **158** of sulphurous acid. Sulphur dioxide gas carried by but not yet reacted in the sulphurous acid is carried into submersion pool of acid **158** because of the proximity of the discharge **80** to the surface **133** of the pool **158**. The carried gas is submerged in the churning submersion pool **158**. The suspended gas is momentarily churned in contact with acid in pool **158** to further concentrate the acid. As unreacted gas rises up through the pool, the unreacted gas is held in contact with water and further reacts to further form concentrate sulphurous acid. The combination of the discharge **80** and its close proximity to the surface **133** of pool of acid **158** creates a means for facilitating and maintaining the submersion of unreacted sulphur dioxide gas discharged from the third conduit into the submersion pool of sulphurous acid to substantially reduce the separation of unreacted sulphur dioxide gas from contact with the sulphurous acid to promote further reaction of the sulphur dioxide gas in the sulphurous acid in an open system without subjecting the sulphur dioxide gas discharged from the third conduit to back pressure or system pressure. That is, discharge **80** positions below the level of the top of weir **148** is contemplated as inconsistent with an open system.

As sulphurous acid enters the mixing tank **130** from the third conduit **76** the level of the pool **132** of sulphurous acid rises until the acid spills over the weir **148** into the outlet section **152**. Sulphurous acid and sulphur dioxide gas flow out of the mixing tank **130** into the drainage pipe **156**. Drainage pipe **156** is provided with a submersion zone in the u-trap **157** in which sulphur dioxide gas is again mixed into the sulphurous acid and which prevents sulphur dioxide gas from exiting the drainage pipe **156** in any significant amount.

Any free floating sulphur dioxide gas in mixing tank **130** rises up to the lid **164**. The lid **164** defines an exhaust vent **202**. Exhaust vent **202** may be coupled with a vent conduit **210**. The vent conduit **210** has a first end which couples with the exhaust vent **202** and a second end which terminates at a fourth conduit **220**. The vent conduit **210** may consist of a length a pipe between vent **202** and the fourth conduit **220**. The fourth conduit **220** comprises auxiliary means **240** for bringing sulphur dioxide gas in the vent conduit and substantially all the water in a supplemental water conduit **294** into contained, codirectional flow whereby remaining sulphur dioxide gas and water are brought into contact with each other.

As shown in FIGS. **2** and **4**, the auxiliary means has a body **240** defining a gas entry **244**, a gas outlet **252**, a supplemental water conduit inlet **246**, and water eductor **250**.

Water enters the auxiliary means **240** through the supplemental water conduit **294** at inlet **246**. The water courses through the eductor as discussed earlier as to the codirectional means. The water eductor **250** draws any free floating sulphur dioxide gas into the exhaust vent conduit **210**. Water and sulphur dioxide gas are brought into contact with each other in fourth conduit **220** by surrounding the gas with water. The water and gas are contained in contact with each other as the gas and water flow down through fourth conduit **220** to react and form an acid of sulphur. This contact containment area does not obstruct the flow of the sulphur dioxide gas. Substantially all of the sulphur dioxide gas in vent conduit **210** reacts with the water in this contact containment area.

In fourth conduit **220**, the water/acid and un-reacted or undissolved sulphur dioxide gas also experience one or more agitation and mixing episodes. For example, as water re-enters fourth conduit **220** at inlet **246**, the flow of water/acid and sulphur dioxide gas is mixed and agitated. The water/acid and sulphur dioxide gas are again contained in contact with each other thereafter. Another similar mixing and agitating episode occurs when the directional flow of the water/acid and sulphur dioxide gas is altered near discharge **264**. As a result, like the water/acid and sulphur dioxide gas in the third conduit **76**, the water/acid and sulphur dioxide gas in fourth conduit **220** may be subject to one or more contact containment portions and one or more agitation and mixing portions. The fourth conduit may have a u-trap **267**. U-trap **267** acts as means to cause bubbles of unabsorbed diatomic nitrogen gas to be held on the upstream side of u-trap **267**. Discharge **264** is also configured with a vent stack **265**. Remaining diatomic nitrogen gas in the system is permitted to escape the system through vent stack **265**. Operation of the system reveals that little, if any, sulphur dioxide gas escapes the system. It is believed that gas that is escaping the system is harmless diatomic nitrogen. This configuration of a sulphur acid generator eliminates the structure, expense, and use of a counter current absorption tower as used in the prior art.

FIGS. **1**, **2** and **3** show a primary pump **280** supplying water through a primary hose **282** to the secondary conduit water inlet **106** at codirectional means **100**. In FIG. **2**, a supplemental or secondary pump supplies water to auxiliary means **240** through a supplemental water conduit hose **294**. It will be appreciated that any pump capable of delivering sufficient water to the system may be utilized and the pump may be powered by any source sufficient to run the pump. A single pump with the appropriate valving may be used or several pumps may be used. It is also contemplated that no pump is necessary at all if an elevated water tank is employed to provide sufficient water flow to the system or if present water systems provide sufficient water pressure and flow.

The present invention may be embodied in other specific forms without departing from its spirit or essential characteristics. The described embodiments are to be considered in all respects only as illustrative and not restrictive. The scope of the invention is, therefore, indicated by the appended claims rather than by the foregoing description. All changes which come within the meaning and range of equivalency of the claims are to be embraced within their scope.

What is claimed and desired to be secured by United States Letters Patent is:

The invention claimed is:

1. A sulphurous acid generator comprising:
 - a source of sulphur dioxide gas;
 - a source of water consisting essentially of water;
 - a source of air/oxygen;
 - a first conduit in fluid communication with the source of sulphur dioxide gas;
 - a second conduit in fluid communication with the source of water, the second conduit comprising a first segment and a second segment;
 - an air injector in fluid communication with the source of air/oxygen, the air injector being positioned along the length of the second conduit and at a distance from the discharge end of the second conduit, the distance being equal to the length of the second segment, wherein the air injector disperses the air/oxygen into the water being conveyed by the first segment of the second

11

conduit to produce an air/oxygen enhanced water that is further conveyed by the second segment of the second conduit; and
 means for blending the sulphur dioxide gas being conveyed by the first conduit with the air/oxygen enhanced water being conveyed by the second segment of the second conduit in a codirectional flow to form a sulphurous acid.
 2. The sulphurous acid generator of claim 1, further comprising:
 a mixing tank into which the blended sulphur dioxide gas and air/oxygen enhanced water is discharged, for further maintaining the sulphur dioxide gas in contact with the air/oxygen enhanced water, the mixing tank having an upper portion and a lower portion.
 3. The sulphurous acid generator of claim 2, wherein the lower portion of the mixing tank defines an outlet through which the sulphurous acid exits the mixing tank.

12

4. The sulphurous acid generator of claim 2, wherein the upper portion of the mixing tank defines an exhaust vent through which any undissolved sulphur dioxide gas exits the mixing tank.
 5. The sulphurous acid generator of claim 4, further comprising:
 a vent conduit connected to the exhaust vent, for conveying the undissolved sulphur dioxide gas;
 a supplemental water conduit in fluid communication with a source of water consisting of essentially water; and
 a secondary means for blending the undissolved sulphur dioxide gas being conveyed by the vent conduit with the water being conveyed by the supplemental water conduit in a codirectional flow to form additional sulphurous acid.

* * * * *