

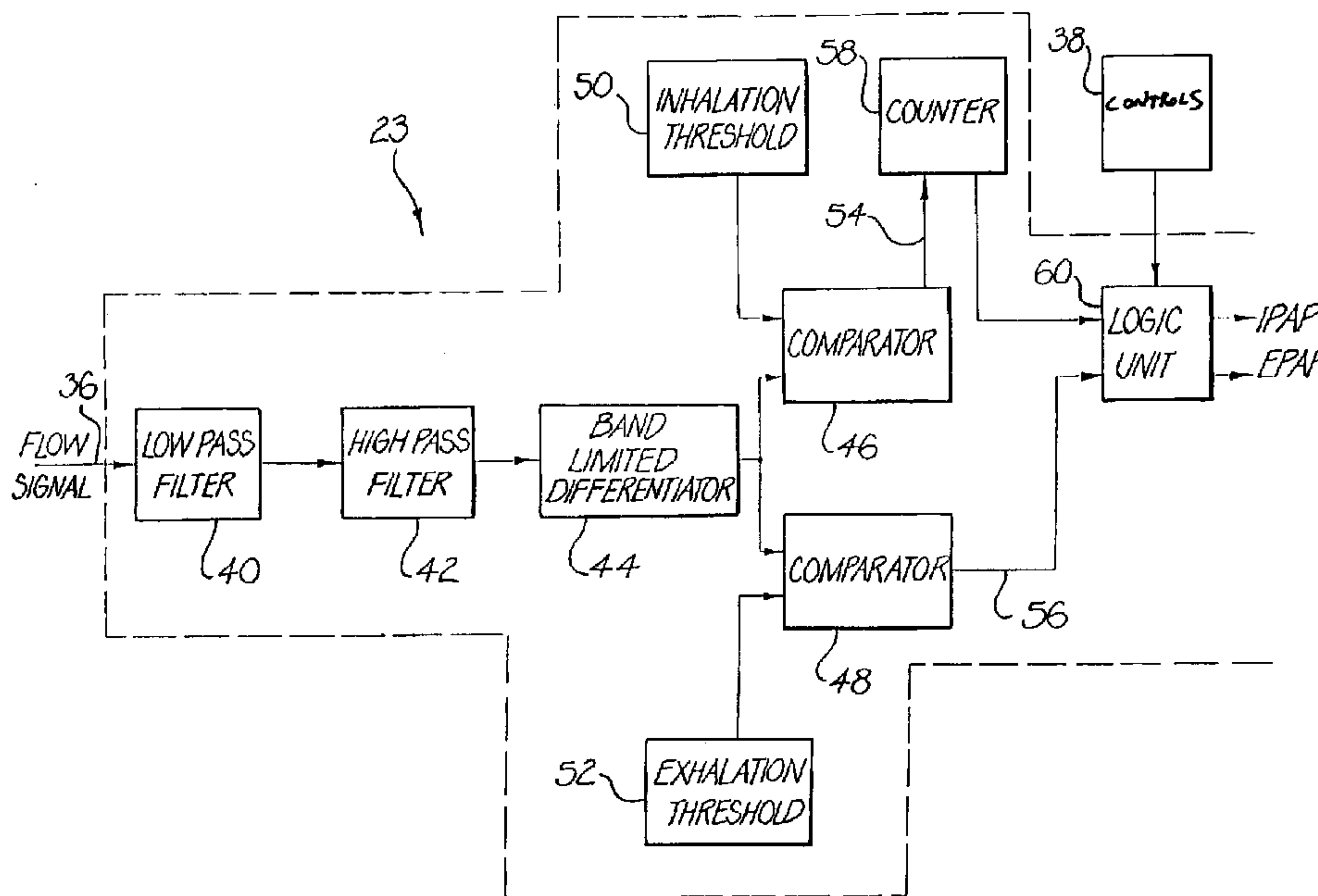

(86) Date de dépôt PCT/PCT Filing Date: 1996/10/17
 (87) Date publication PCT/PCT Publication Date: 1997/05/01
 (45) Date de délivrance/Issue Date: 2007/07/31
 (85) Entrée phase nationale/National Entry: 1998/04/23
 (86) N° demande PCT/PCT Application No.: AU 1996/000652
 (87) N° publication PCT/PCT Publication No.: 1997/015343
 (30) Priorité/Priority: 1995/10/23 (AUPN 6167)

(51) Cl.Int./Int.Cl. *A61M 16/00* (2006.01)
 (72) Inventeurs/Inventors:
 BRYDON, JOHN WILLIAM ERNEST, AU;
 WILLSON, GRANT, AU
 (73) Propriétaire/Owner:
 RESMED LIMITED, AU
 (74) Agent: SIM & MCBURNEY

(54) Titre : DUREE D'INSPIRATION DURANT UNE VENTILATION SPONTANEE EN PRESSION POSITIVE CONTINUE
 OU UN TRAITEMENT EN ASSISTANCE RESPIRATOIRE
 (54) Title: INSPIRATORY DURATION IN CPAP OR ASSISTED RESPIRATION TREATMENT



(57) **Abrégé/Abstract:**

Apparatus for the supply of breathable gas cyclically at an inspiratory pressure and the lower expiratory pressure substantially in synchronism with a patient's (16) respiration is disclosed. A flow generator (10) is coupled to a gas delivery system (12) to deliver the breathable gas to the patient's airways. A motor controller (23) receives a signal (36) representing respiratory flow. A motor controller (23) out-puts a control signal (24) has control over the electric motor (25) and thus the turbine (22) to generate the required inspiratory and expiratory pressures. The controller (23) detects transitions between inspiration and expiration from the flow signal (36) to discriminate between patient inspiration and expiration. A counter (58) counts a first time duration commenced from the last transition to inspiration, whereby if the first time duration elapses before a transition to expiration, the controller (23) causes the supply of the expiration pressure. Furthermore, another counter (62) counts a second time duration commenced from the last transition to inspiration that forces the turbine (22) to supply the inspiratory pressure until the second time duration elapses even if during the second time duration there is a transition to expiration by the patient.



PCT

WORLD INTELLECTUAL PROPERTY ORGANIZATION
International Bureau

INTERNATIONAL APPLICATION PUBLISHED UNDER THE PATENT COOPERATION TREATY (PCT)

(51) International Patent Classification ⁶ : A61M 16/00	A1	(11) International Publication Number: WO 97/15343 (43) International Publication Date: 1 May 1997 (01.05.97)
(21) International Application Number: PCT/AU96/00652 (22) International Filing Date: 17 October 1996 (17.10.96) (30) Priority Data: PN 6167 23 October 1995 (23.10.95) AU (71) Applicant (for all designated States except US): RESMED LIMITED [AU/AU]; 82 Waterloo Road, North Ryde, NSW 2113 (AU). (72) Inventors; and (75) Inventors/Applicants (for US only): BRYDON, John, William, Ernest [AU/AU]; 37/10 Carr Street, Waverton, NSW 2060 (AU). WILLSON, Grant [AU/AU]; 57 Northwood Street, Camperdown, NSW 2050 (AU). (74) Agent: SPRUSON & FERGUSON; G.P.O. Box 3898, Sydney, NSW 2001 (AU).	(81) Designated States: AL, AM, AT, AU, AZ, BA, BB, BG, BR, BY, CA, CH, CN, CU, CZ, DE, DK, EE, ES, FI, GB, GE, HU, IL, IS, JP, KE, KG, KP, KR, KZ, LC, LK, LR, LS, LT, LU, LV, MD, MG, MK, MN, MW, MX, NO, NZ, PL, PT, RO, RU, SD, SE, SG, SI, SK, TJ, TM, TR, TT, UA, UG, US, UZ, VN, ARIPO patent (KE, LS, MW, SD, SZ, UG), Eurasian patent (AM, AZ, BY, KG, KZ, MD, RU, TJ, TM), European patent (AT, BE, CH, DE, DK, ES, FI, FR, GB, GR, IE, IT, LU, MC, NL, PT, SE), OAPI patent (BF, BJ, CF, CG, CI, CM, GA, GN, ML, MR, NE, SN, TD, TG). Published <i>With international search report.</i>	

(54) Title: INSPIRATORY DURATION IN CPAP OR ASSISTED RESPIRATION TREATMENT**(57) Abstract**

Apparatus for the supply of breathable gas cyclically at an inspiratory pressure and the lower expiratory pressure substantially in synchronism with a patient's (16) respiration is disclosed. A flow generator (10) is coupled to a gas delivery system (12) to deliver the breathable gas to the patient's airways. A motor controller (23) receives a signal (36) representing respiratory flow. A motor controller (23) outputs a control signal (24) has control over the electric motor (25) and thus the turbine (22) to generate the required inspiratory and expiratory pressures. The controller (23) detects transitions between inspiration and expiration from the flow signal (36) to discriminate between patient inspiration and expiration. A counter (58) counts a first time duration

commenced from the last transition to inspiration, whereby if the first time duration elapses before a transition to expiration, the controller (23) causes the supply of the expiration pressure. Furthermore, another counter (62) counts a second time duration commenced from the last transition to inspiration that forces the turbine (22) to supply the inspiratory pressure until the second time duration elapses even if during the second time duration there is a transition to expiration by the patient.

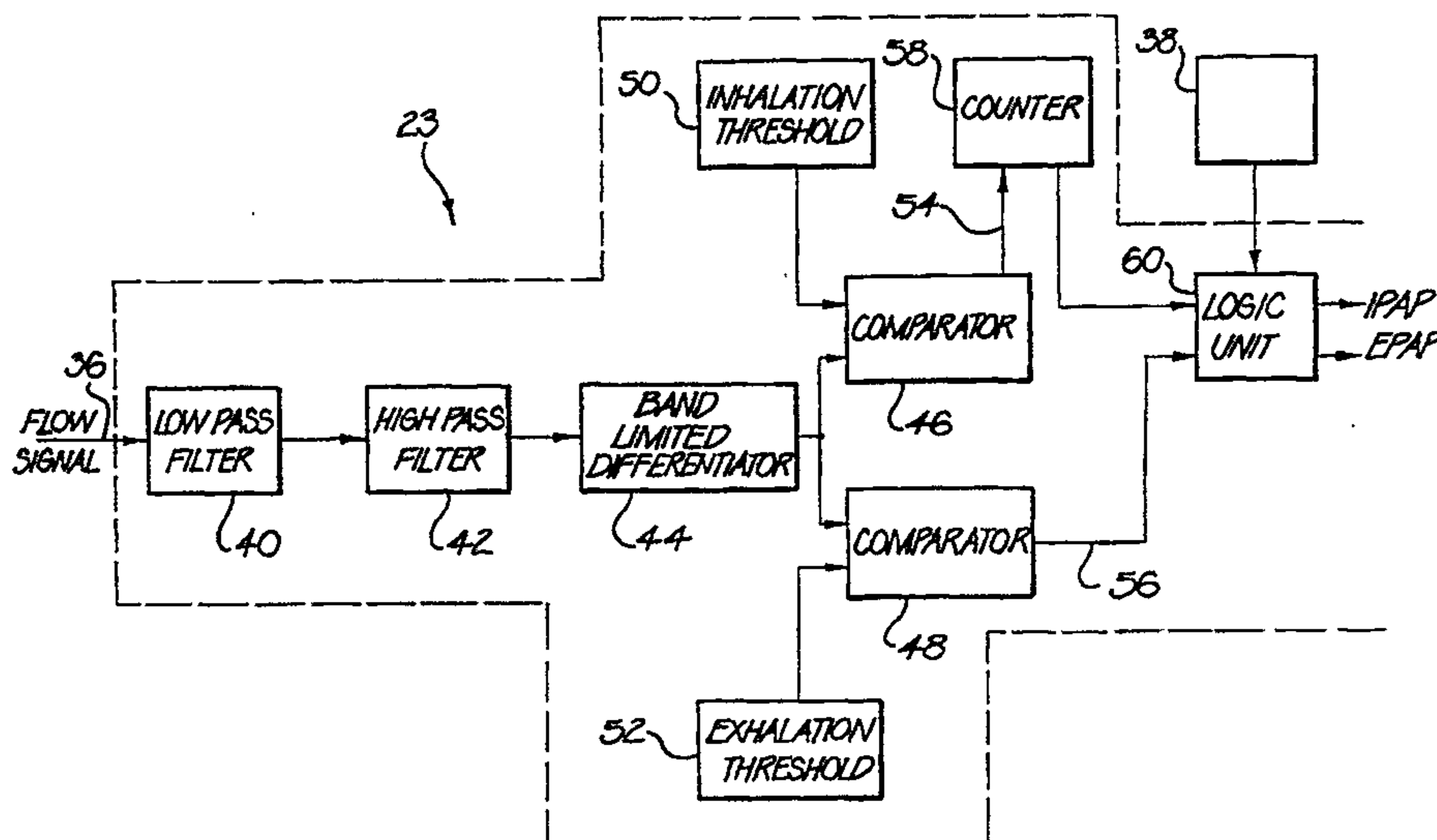

Inspiratory Duration in CPAP or Assisted Respiration Treatment

Field of the Invention

This invention relates to the selection and/or automatic control of IPAP
5 duration during CPAP or assisted respiration treatment. In preferred non-exclusive
forms, it relates to the selection of a variable maximum IPAP duration, a variable
minimum IPAP duration and the automatic adjustment of a variable IPAP duration, or
combinations of these.

In this specification references to "transitions between inspiration and
10 expiration" are to be understood as transitions both from inspiration to expiration and
from expiration to inspiration.

Background of the Invention

The administration of non-invasive CPAP (Continuous Positive Airway
15 Pressure) is an effective way of treating patients who suffer from OSA (Obstructive
Sleep Apnea) and upper airway resistance syndrome. CPAP treatment effectively acts
as a pneumatic splint of the patient's upper airway. Common to all forms of non-
invasive CPAP apparatus is a nose, mouth or face mask which is fitted to a patient and
connected to a flow generator via a flexible air delivery tube/conduit. The flow
20 generator includes an electric motor driving a turbine to supply air or breathable gas for
the administration of CPAP treatment to the patient during sleep. The positive air
pressures supplied at the entrance to the patient's airway typically is in the range 2-20
cm H₂O.

In bilevel CPAP, the pressure of the delivered air or breathable gas is ideally
25 switched between two levels coinciding (in synchronism) with patient breathing. The
pressure required to maintain adequate airway patency is typically substantially higher
in inspiration than in expiration. Further, the pressure level required during inspiration
is approximately equal to the single fixed pressure level used in CPAP therapy. This
observation permits the administration of a lower pressure (referred to as EPAP) in

- 2 -

expiration, and a higher pressure (referred to as IPAP) during inspiration. Therefore, the mean pressure delivered to the patient is reduced compared with CPAP therapy, leading to increased comfort and potential compliance. In some instances bilevel CPAP may also be used to provide respiratory assistance or ventilation. Much of the practical
5 difficulty in designing CPAP apparatus is the accurate detection of the transition between inspiration to expiration so that synchronism with respiration is maintained.

When bilevel CPAP treatment is employed using only a nose mask, for some patients the higher IPAP pressure can introduce a mouth leak by which air entering the nose escapes via the mouth. The presence of a mouth leak during IPAP makes it
10 difficult for the CPAP apparatus to accurately detect when the patient exhales. The IPAP pressure therefore may erroneously be maintained during expiration, thereby increasing the work of breathing, possibly leading to an arousal from sleep.

One method of circumventing the problem of mouth-leak is to use a full face mask or a combined nose/mouth mask; however this may lead to discomfort for some
15 patients and effectively sealing the mask is difficult.

An alternate manner of minimising the effect of mouth-leak is to limit the maximum time for which the CPAP apparatus can remain in the IPAP state. With an appropriate limit on the duration of the IPAP time, the machine eventually 'times-out' and reverts to EPAP treatment pressure if it is unable to detect, as a result of a leak,
20 that the patient has exhaled. When the patient next inhales, the CPAP apparatus detects this occurrence and reverts to the IPAP treatment pressure.

In all known bilevel CPAP apparatus the IPAP time-out is of a fixed duration, typically three seconds, which is longer than the usual maximum inspiratory time. From clinical trials conducted by the present inventors, it has become apparent that
25 problems still arise, as it is possible for a patient to take a number of breaths before the time-out occurs. The patient must therefore still breath against the IPAP pressure, so the work of breathing is increased. The benefits of the delivered therapy are therefore diminished and, in some cases, the device may act to the patient's detriment.

The present invention is directed to overcoming or at least ameliorating one or more of the above-mentioned disadvantages.

Disclosure of the Invention

In one broad form, the invention discloses a controller for a flow generator to supply breathable gas cyclically at an inspiration pressure and at a lower expiration pressure substantially in synchronism with the patient's respiration.

In accordance with an aspect of the present invention there is provided a controller for a flow generator to supply breathable gas cyclically at an inspiration pressure and at an expiration pressure substantially in synchronism with a patient's respiration, the controller comprising:

a data processor for receiving an input respiration flow signal and for detecting transitions between inspiration and expiration from said flow signal to discriminate between patient inspiration and expiration, and for outputting a control signal to the flow generator to set the inspiration pressure and the expiration pressure;

wherein, if a first time duration measured from the last transition to inspiration elapses before the data processor detects a transition to expiration by the patient, the output signal from the data processor causes the flow generator to supply said expiration pressure; and further

wherein the data processor is set to establish a second time duration, shorter than or equal to said first time duration, commencing from the last transition to inspiration in which the flow generator may supply said inspiration pressure until said second time duration elapses even if during said second time duration there is a transition to expiration by the patient.

In accordance with another aspect of the present invention there is provided a controller for a flow generator to supply breathable gas cyclically at an inspiration pressure and at an expiration pressure substantially in synchronism with a patient's respiration, the controller comprising:

(a) a data processor for receiving an input respiration flow signal and for detecting transitions between inspiration and expiration from said flow signal to discriminate between patient inspiration and expiration, and for outputting a control signal to the flow generator to set the inspiration pressure and the expiration pressure;

(b) a first timer to manually adjust or select a first duration commencing from the last transition to inspiration, whereby if said first time duration elapses before the data

processor detects a transition to expiration by the patient, the output signal from the data processor causes the flow generator to supply said expiration pressure; and

(c) a second timer to manually adjust or select a second time duration, shorter than or equal to said first time duration, commencing from said last transition to inspiration corresponding to the data processor forcing said flow generator to supply said inspiration pressure until said second time duration elapses even if during said second time duration there is a transition to expiration by the patient.

The time duration can be user adjustable. In another form, there is provided a second time duration commencing from the last transition to inspiration corresponding to the data processing means forcing said flow generator to supply said inspiration pressure until said second time duration elapses even if during said second time duration there is a transition to expiration by the patient. Furthermore, data processing means can periodically update said first time duration based on one or more subsequent respiratory transitions to expiration and whether the first time duration elapses before one or more of said subsequent transitions occur, to converge the elapse of said first time duration with said subsequent transitions to expiration.

The invention further discloses CPAP or assisted respiration apparatus comprising a controller as described above, a flow generator coupled to the controller for supplying breathable gas to a gas delivery system providing the breathable gas to the patient's airway, and a flow sensor located in said gas delivery system

According to another aspect of the present invention there is provided an apparatus for the supply of breathable gas cyclically at an inspiratory pressure and an expiration pressure substantially in synchronism with the patient's respiration, the apparatus comprising:

- a turbine to pressurize inlet breathable gas;
- a variable speed electric motor to control operation of said turbine and thus the pressure of breathable gas delivered by the turbine;
- a gas delivery system coupled to the turbine and providing said breathable gas to the patient's airway;
- a flow sensor located in said gas delivery system to provide a respiration flow signal therefrom; and
- a controller comprising:

(a) a data processor for receiving said respiration flow signal and for detecting transitions between inspiration and expiration from said flow signal to

4a

discriminate between patient inspiration and expiration, and for outputting a control signal provided to the motor to set the inspiration pressure and the expiration pressure;

(b) a first timer to manually adjust or select a first time duration commencing from the last transition to inspiration, whereby if said first time duration elapses before the data processor detects a transition to expiration by the patient, the output signal from the data processor causes the flow generator to supply said expiration pressure; and

(c) a second timer to manually adjust or select a second time duration, shorter than or equal to said first time duration, commencing from said last transition to inspiration corresponding to the data processor forcing said flow generator to supply said inspiration pressure until said second time duration elapses even if during said second duration there is a transition to expiration by the patient.

According to another aspect of the present invention there is provided a flow generator for supplying breathable gas cyclically at an inspiration pressure and an expiration pressure substantially in synchronism with the patient's respiration, the flow generator comprising:

a turbine to pressurize inlet breathable gas;

a variable speed electric motor to control operation of said turbine and thus the pressure of breathable gas delivered by the turbine; and

a controller comprising:

(a) a data processor for receiving an input respiration flow signal and for detecting transitions between inspiration and expiration from said flow signal to discriminate between patient inspiration and expiration, and for outputting a control signal to the flow generator to set the inspiration pressure and the expiration pressure;

(b) a first timer to manually adjust or select a first time duration commencing from the last transition to inspiration, whereby if said first time duration elapses before the data processor detects a transition to expiration by the patient, the output signal from the data processor causes the flow generator to supply said expiration pressure; and

(c) a second timer to manually adjust or select a second time duration, shorter than or equal to said first time duration, commencing from said last transition to inspiration corresponding to the data processor forcing supply of inspiration pressure until said second time duration elapses even if during said time duration there is a transition to expiration by the patient.

The invention further discloses a method for controlling the supply of breathable gas to a patient cyclically at an inspiration pressure and at a lower expiration pressure substantially in synchronism with the patient's respiration.

According to yet another aspect of the present invention there is provided a
5 method for controlling the supply of breathable gas to a patient cyclically at an inspiration pressure and at a lower expiration pressure substantially in synchronism with a patient's respiration, the method comprising:

- (a) measuring patient respiratory flow;
- (b) detecting transitions between inspiration and expiration from said
10 respiratory flow to discriminate between patient inspiration and expiration;
- (c) controlling the pressure of gas to be at the inspiration pressure during patient inspiration and at the expiratory pressure during patient expiration;
- (d) prescribing a first time duration commencing from the last transition to inspiration by the patient, and if said duration elapses before patient transition to
15 expiration, causing the pressure of gas to be at the expiratory pressure; and
- (e) prescribing a second time duration commencing from the last transition to inspiration, shorter than or equal to said first time duration, and causing the pressure to gas to be at the inspiratory pressures until the elapse of said second time duration even if there is a transition to expiration by the patient during the second time duration.

20 According to another aspect of the present invention there is provided an assisted respiration apparatus having a controller for a flow generator for supplying breathable gas to a gas delivery system providing the breathable gas to a patient's airways, and a flow sensor in communication with said gas delivery system, the controller comprising:

25 signal processing means for receiving an input gas delivery flow signal and for discriminating transitions between patient inspiration and expiration based on said flow signal;

first timer means for measuring a first time duration commencing from the last transition to inspiration by the patient;

30 logic means for outputting one or more control signals to the flow generator to designate an inspiration pressure or an expiration pressure produced by said flow generator, wherein the flow generator is caused to cyclically output a predetermined

4c

inspiration pressure and a predetermined expiration pressure substantially in synchronism with a patient's respiration;

wherein, if said first time duration becomes greater than a variable maximum IPAP time-out before the signal processing means detects a transition to expiration by the patient, the logic means is operable to output a signal that causes the flow generator to supply said expiration pressure; and

wherein said variable maximum IPAP time-out is automatically incremented or decremented by said logic unit during one or more subsequent respiration cycles of the patient so as to become closer in duration to an inspiratory time of said patient, whereby a synchronism with the patient's respiration is achieved.

According to a further aspect of the present invention there is provided an assisted respiration apparatus having a controller for a flow generator for supplying breathable gas to a gas delivery system providing the breathable gas to a patient's airways, and a flow sensor in communication with said gas delivery system, the controller comprising:

signal processing means for receiving an input gas delivery flow signal and for discriminating transitions between patient inspiration and expiration based on said flow signal;

logic means for outputting one or more control signals to the flow generator to designate an inspiration pressure or an expiration pressure produced by said flow generator, wherein the flow generator is caused to cyclically output a predetermined inspiration pressure and a predetermined expiration pressure substantially in synchronism with a patient's respiration;

wherein the signal processing means is operable to discriminate a transition of a patient's respiration from inhalation-to-exhalation or from exhalation-to-inhalation based on a predetermined threshold value of the time rate-of-change of said flow signal.

In an assisted respiration apparatus having a flow generator supplies breathable gas to a patient cyclically at an inspiration pressure and at an expiration pressure substantially in synchronism with a patient's respiration, the flow generator comprising:

pressurizing means operable to pressurize inlet breathable gas and deliver a controlled outlet pressure of breathable gas;

a controller receiving an input respiratory flow signal and operable to detect

4d

transitions between inspiration and expiration from said flow signal to discriminate between the patient inspiration and expiration, and for outputting a control signal to cause the pressurizing means to output a predetermined inspiration pressure and a predetermined expiration pressure cyclically and substantially in synchronism with a patient's respiration, and further operable to measure a first time duration commencing from the last transition to inspiration, wherein an inspiration time-out duration is set via user control input means, and if said first time duration becomes greater than said inspiration time-out duration before the signal processing means detects a transition to expiration by the patient, the controller is operable to output a signal that causes the flow generator to supply said predetermined expiration pressure; and

wherein the controller is operable to discriminate an exhalation-to-inhalation transition based on a predetermined inhalation threshold value of a time rate of change of said flow signal and is further operable to discriminate an inhalation-to-exhalation transition based on a predetermined exhalation threshold value of a time rate of change of said flow signal.

The provision of a variable maximum inspiratory treatment pressure duration is advantageous in maintaining synchronism between CPAP apparatus and a patient's breathing, thereby maintaining efficacy of the treatment and ensuring that the workload of breathing is not increased. This is particularly so for those patients who exhibit mouth-leak during IPAP.

For a small percentage of patients receiving CPAP treatment, for example those with REM hypoventilation, only small inspiratory effort is made. Under the bilevel regime, it is conventionally the case that because of the small inspiratory effort the CPAP apparatus will make a transition to EPAP while the patient still is inspiring.

5 Thus an advantage of a variable minimum inspiratory duration is that the patient does not have to make a sustained respiratory effort in order that the IPAP pressure be maintained. Adequate ventilation or respiratory assistance therefore can be assured. Further, the ability to vary the minimum IPAP duration enables the physician to match the therapy to the patient's normal breathing whilst asleep.

10 An advantage of the automatic adjustment of the maximum IPAP duration is that variations in a patient's breathing, which might occur overnight, seasonally or with disease progression, can be accounted for and near synchronism with the patient's respiration maintained.

15 **Brief Description of the Drawings**

Embodiments of the invention now will be described with reference to the accompanying drawings, in which:

Fig. 1 is a schematic block diagram of bilevel CPAP apparatus;

20 Fig. 2 is a functional block diagram of a respiration detection circuit incorporating variable maximum IPAP duration;

Figs. 3a to 9b show clinical data of respiratory flow and bi-level CPAP treatment pressure for a number of patients with and without maximum IPAP duration;

Fig. 10 is a functional block diagram of a respiration detection circuit incorporating a variable minimum IPAP duration; and

25 Fig. 11 is a functional block diagram showing automatic adjustment of IPAP duration.

Description of Preferred Embodiments and Best Mode

The embodiments described relate to CPAP apparatus and treatment, however, the invention is to be understood as being equally applicable to assisted respiration devices. Referring then to Fig. 1, the CPAP apparatus comprises a flow generator 10 coupled by a flexible delivery tube or conduit 12 to, in this case, a nose mask 14 worn by a patient 16. The flow generator 10 broadly comprises an electric motor 18 that is powered by a motor power supply 20. In turn, the electric motor 18 has mechanical coupling with a turbine 22 that outputs either air or breathable gas at a pressure elevated above atmospheric pressure to the delivery tube 12. The output delivery pressure from the turbine 22 is governed by the rotational speed of the electric motor 18, the speed therefore being the controlled variable relative to the desired CPAP treatment pressure. The motor 18 speed is controlled by the motor controller 23 which effects changes in motor speed by means of a control signal on control line 24 provided to the motor power supply 20. Thus motor speed is controlled by means of varying the motor power supply 20.

The motor controller 23 receives an electrical signal on control line 26 representative of, in this case, delivery pressure from the turbine 22 as measured by the pressure transducer 28 which is connected via a sensing line 29 to a sensing port 27 proximate to the turbine outlet. The sensing of delivery pressure is important in maintaining regulation of treatment pressure.

An inline flow transducer 34 also is provided near the outlet to the turbine 22, and supplies a flow signal to the motor controller 23 on line 36. The function of the flow sensor will be presently described.

In one preferred form, the motor 18 driving the turbine 22 can be a PAPST™ ECA 27-11 brushless DC motor. Being a DC motor, its speed is directly proportional to the armature voltage. The particular motor described has integral Hall-effect sensors, thus providing a measure of motor angular rotational speed required for speed (and hence delivery pressure) regulation, that signal being output from the motor 18 to the motor controller 23 control line 30.

- 7 -

The pressure transducer 28 can be such as a Motorola™ MPX 2010DP type. The flow transducer can be such as a Micro Switch™ AWM2200V type. The motor controller 23 can be implemented by any commercially available microprocessor, although one preferred form is the 8-bit Motorola™ MC68HC805B6 micro-controller.

5 As briefly described above, bilevel CPAP treatment controls the pressure of the air or breathable gas supplied to the entrance of the patient's airway as a higher inspiratory pressure in phase with the patient's inspiration, and a lower expiratory pressure in phase with the patient's expiration. Typical differences between the IPAP and EPAP treatment pressures are 6-12 cm H₂O. In order to implement bilevel CPAP
10 treatment, it is necessary to detect the transitions between patient inspiration and expiration so that the IPAP and EPAP treatment pressures can be in synchronism with the respective phases of respiration. Such transitions are detected by means of the flow transducer 34, in that a zero crossing or threshold value can be discriminated as a trigger to a transition event. In this regard, reference can be had to the bilevel CPAP
15 apparatus commercially available from the present applicant and sold under the trade mark "VPAP".

Fig. 1 also shows a set of controls 38, which can be in the form of potentiometers, pushbuttons or the like for manual adjustment of parameters relating to IPAP duration. The controls may be located within the casing of the CPAP apparatus
20 so as only to be accessed by a physician or trained technician, or in the alternative they may be generally accessed from outside of the casing for free manipulation by a patient directly or by a physician or technician.

Fig. 2 is a functional block diagram that represents logic elements, typically implemented by one or more computer programs, within the motor controller 23. The
25 signal representative of flow on line 36 is input to a low pass filter 40 typically having an upper limiting frequency of 20 Hz and intended to remove noise in the flow signal. The output of the low pass filter is supplied to a high pass filter 42, typically having a lower limiting frequency of 0.5 Hz that removes non-respiratory components of the signal. The output of the high pass filter then is supplied to a band-limited

- 8 -

differentiator 44, the output of which thus represents the time rate of change of the flow signal. The output of the differentiator 44 is provided to separate comparators 46,48. Associated with each of the comparators 46,48 is a respective threshold reference unit 50,52. The comparators and respective threshold reference units relate to the separate
5 detection of inspiration and expiration so as to control the supplying of IPAP and EPAP treatment pressure to a patient.

The comparator 46 thus compares the time differentiated and filtered flow signal with a threshold reference from the threshold reference unit 50, and when the threshold is exceeded (in the negative sense) an "inhalation detection signal" 54 is
10 generated. That is, the occurrence of negative gradient in the flow signal represents a transition to inspiration. Conversely, a positive gradient in the flow signal represents a transition to expiration. In that case, the reference threshold supplied by the threshold reference unit 52 to the comparator 48 is positive, with the output 56 from the
15 comparator 48 representing an "exhalation detection signal" being provided to a logic unit 60.

The inhalation detection signal 54 is passed to a counter 58, which is in the nature of a resettable timer that determines the duration for which the inhalation detection signal 54 has been active. The output of the counter is provided to the logic
unit 60.

The controls 38 also provide an input to the logic unit 60, by which the
20 maximum allowable IPAP duration (time-out) can be set. The duration/time-out typically will be set to the patient's prevailing inspiratory time. In this way, the logic unit 60 watches the state of the counter 58 following commencement of a patient inspiration, and if the counter does not reset (for reason of a transition to expiration)
25 before the elapse of the maximum duration/time-out set by the controls 38, then the logic unit 60 forces a change to the EPAP state. An output of the logic unit 60 therefore is an EPAP control signal that has control over the state of operation of the CPAP apparatus as to provision of either EPAP treatment pressure. Conversely, the other output to the logic unit 60 is an IPAP control signal. Selection, control and

regulation of the respective EPAP and IPAP treatment pressures is performed by other logic units of the motor controller 23 in the conventional manner.

In all of Figs. 3a-9b the clinical traces denominated "a" represent approximate respiratory flow rate. The convention adopted is that negative flow equates to inspiration, and as follows, positive flow relates to expiration. The traces denominated "b" represent CPAP treatment pressure. The treatment is in the nature of bi-level CPAP, with the higher treatment pressure intended to correspond with patient inspiration, and the lower treatment pressure intended to correspond with patient expiration. The duration of the inspiratory and expiratory portions of the CPAP treatment are as provided by bi-level CPAP apparatus, such as the present applicant's "VPAP" apparatus, that seek to maintain synchrony with transitions in the patient's respiration. Thus the respective duration of the inspiratory and expiratory portions of the CPAP treatment can be seen to vary in time.

The patient from whom the respiratory traces shown in Figs. 3a and 3b were made suffers from OSA and REM (Rapid Eye Movement) hypoventilation. A study of the respective flow and pressure traces reveals asynchrony following the third, fourth, fifth and sixth transitions from IPAP to EPAP. This is a pattern that is due essentially to mouth leak, and can at times result in patient arousal. Such asynchrony can, in some patients, lead to ineffective ventilation and may increase the work of breathing.

The traces shown in Figs. 5a and 5b are for the same patient as for Figs. 3a-4b, however with maximum IPAP duration being practiced. As can be noted, there is a dramatic improvement in the synchronism of the patient's respiration with treatment pressures.

The traces shown in Figs. 6a-7b relate to a patient having severe lung disease. As can be seen from Figs. 6a and 6b, the duration of and time of transition between the IPAP and EPAP treatment pressures are only poorly in synchronism with the patient's respiration. Figs. 7a and 7b show an improved synchronism where maximum IPAP duration is in effect.

Figs. 8a-9b relate to a separate patient suffering severe lung disease. Figs. 8a and 8b show the event of the maximum IPAP duration being defeated with the subsequent immediate asynchronous nature of the patient's respiration. The traces of Figs. 9a and 9b show an example of respiration and treatment pressure showing a high
5 degree of synchronism with maximum IPAP duration in effect.

Fig. 10 is a slightly modified form of the arrangement shown in Fig. 2, in that the output from the comparator 46, indicative of a transition to inspiration (the commencement of inspiration) also is provided to the logic unit 60. Furthermore, a second counter 62 is provided, also receiving the output from the comparator 46 and, in
10 turn, its output being provided to the logic unit 60. The counter 62 is free-running, in the sense that it is not resettable in the absence of continuing inspiration, manifested by a negative gradient in the flow signal. The controls 38 also include the facility for selecting the minimum IPAP duration, which is provided to the logic unit 60. The minimum duration typically will be set at 300 ms, meaning that following sensing of
15 commencement of inspiration, even if the output of the comparator 46 changes in response to detect a change to expiration, the IPAP state will be forced by the logic unit 60 until expiration of the 300 ms minimum duration determined from the counter 62. Thus the logic unit 60 gives precedence to the signal provided by the second counter 62 ignoring any resetting of the first counter 58 until the minimum duration has elapsed.

20 The embodiment shown in Fig. 10 thus provides the function of having a selectable minimum IPAP duration following detection of commencement of inspiration regardless of any sensed change to expiration, and has a maximum duration/time-out that forces a change to EPAP treatment in the absence of any earlier sensed change of state to expiration. The counter 62 is automatically reset when it reaches its maximum
25 value.

Fig. 11 shows an arrangement for the automatic adjustment of the maximum IPAP duration/time-out that is a modification of the arrangement shown in Fig. 10. In this way, the time-out period can automatically adjust to account for variations in a patient's breathing. The output from the resettable counter 58 is provided to a further

- 11 -

comparator 64. The counter 58 has the same role as before in counting time since the last transition to inspiration. The signal 66 fed-back from the logic unit 60 to the comparator 64 represents the "current IPAP time-out" value, and this is compared with the counter value by the comparator 64. The output from the comparator 64 will change state when the current IPAP time-out value elapses and there has been no detection of a transition to expiration, in which case there will be an incremental increase of the current IPAP time out towards the maximum time-out limit specified by the relevant storage unit 68. In the event that the counter 58 times-out in advance of the current IPAP time-out value, then the logic unit 60 will attempt to adapt the current IPAP time-out value by way of reduction in an incremental manner towards the minimum time-out limit set by the relevant storage unit 70. Indicative minimum and maximum time-out limits are 300 ms and 3 seconds. The maximum and minimum time-out limits held by the respective storage units 68,70 can be set by the physician using a potentiometer or other input means. Alternatively, default values can be used. In this manner, the current IPAP time-out value will be continuously updated to be close to the patient's prevailing inspiratory time, so that if the transition to inspiration is not detected or triggered for whatever reason, the time-out period will be closest to the normal period, and so a change to EPAP treatment pressure will result still substantially in synchronism with the patient's respiration.

Clearly, one, two or all of the embodiments can be implemented for the control of CPAP or assisted respiration apparatus and fall within the broad scope of the present invention.

CLAIMS:

1. A controller for a flow generator to supply breathable gas cyclically at an inspiration pressure and at an expiration pressure substantially in synchronism with a patient's respiration, the controller comprising:
 - a data processor for receiving an input respiration flow signal and for detecting transitions between inspiration and expiration from said flow signal to discriminate between patient inspiration and expiration, and for outputting a control signal to the flow generator to set the inspiration pressure and the expiration pressure;
 - wherein, if a first time duration measured from the last transition to inspiration elapses before the data processor detects a transition to expiration by the patient, the output signal from the data processor causes the flow generator to supply said expiration pressure; and further
 - wherein the data processor is set to establish a second time duration, shorter than or equal to said first time duration, commencing from the last transition to inspiration in which the flow generator may supply said inspiration pressure until said second time duration elapses even if during said second time duration there is a transition to expiration by the patient.
2. A controller as claimed in claim 1, wherein said first time duration is not adjustable by the patient.
3. A controller as claimed in any one of claims 1 and 2, wherein said data processor periodically updates said first time duration based on one or more subsequent respiratory transitions to expiration and whether the first time duration elapses before one or more of said subsequent transitions occur to converge the elapse of said first time duration with said subsequent transitions to expiration.

4. The controller as claimed in any one of claims 1-3, wherein said data processor differentiates said respiratory flow signal, the polarity of the differentiated signal representing either inspiration or expiration.
5. A controller as claimed in any one of claims 1-4, wherein said second time duration is patient adjustable.
6. A controller as claimed in any one of claims 1-5, further comprising a first timer to set the first time duration and a second timer to set the second time duration.
7. A flow generator for supplying breathable gas cyclically at an inspiration pressure and an expiration pressure substantially in synchronism with a patient's respiration, the flow generator comprising:
 - a turbine to pressurize inlet breathable gas;
 - a variable speed electric motor to control operation of said turbine and thus the pressure of breathable gas delivered by the turbine; and
 - a controller according to any one of claims 1-6.
8. A flow generator as claimed in claim 7, further comprising a housing within which are located said turbine, said electric motor and said controller, and further wherein said first time duration cannot be adjusted by the patient.
9. A method for controlling a supply of breathable gas to a patient cyclically at an inspiration pressure and at a lower expiration pressure substantially in synchronism with a patient's respiration, the method comprising:
 - (a) measuring patient respiratory flow;

(b) detecting transitions between inspiration and expiration from said respiratory flow to discriminate between patient inspiration and expiration;

(c) controlling the pressure of gas to be at the inspiration pressure during patient inspiration and at the expiratory pressure during patient expiration;

(d) prescribing a first time duration commencing from the last transition to inspiration by the patient, and if said duration elapses before patient transition to expiration, causing the pressure of gas to be at the expiratory pressure; and

(e) prescribing a second time duration commencing from the last transition to inspiration, shorter than or equal to said first time duration, and causing the pressure to gas to be at the inspiratory pressures until the elapse of said second time duration even if there is a transition to expiration by the patient during the second time duration.

10. A method as claimed in claim 9, further comprising:

(a) updating said first time duration based on one or more subsequent respiratory transitions to expiration and whether the first time duration elapses before one or more of said subsequent transitions occur to converge the elapse of said first time duration with said subsequent transitions to expiration.

11. A method as claimed in any one of claims 9 and 10, wherein step (b) further comprises differentiating a signal of said respiratory flow, the polarity of the differentiated signal representing either inspiration or expiration.

12. An apparatus for the supply of breathable gas cyclically at an inspiratory pressure and an expiration pressure substantially in synchronism with a patient's respiration, the apparatus comprising:

a turbine to pressurize inlet breathable gas;

a variable speed electric motor to control operation of said turbine and thus the pressure of breathable gas delivered by the turbine;

a gas delivery system coupled to the turbine and providing said breathable gas
5 to the patient's airway;

a flow sensor located in said gas delivery system to provide a respiration flow signal therefrom; and

a controller as claimed in any one of claims 1 to 6.

10 13. An apparatus as claimed in claim 12, wherein said gas delivery system comprises a nose mask coupled to a flexible conduit.

14. An apparatus as claimed in any one of claims 12 and 13, further comprising a housing within which are located said turbine, said electric motor and said controller,
15 and further wherein said first time duration cannot be adjusted by the patient.

15. An apparatus as claimed in any one of claims 12 and 14, wherein said gas delivery system comprises a face mask coupled to a flexible conduit.

20 16. An apparatus as claimed in any one of claims 12, 13 or 15, wherein said first time duration is not adjustable by the patient.

17. An apparatus as claimed in any one of claims 12 to 16, wherein said data processor periodically updates said first time duration based on one or more subsequent
25 respiratory transitions to expiration and whether the first time duration elapses before one or more of said subsequent transitions occur to converge the elapse of said first time duration with said subsequent transitions to expirations.

18. An apparatus as claimed in any one of claims 12-17, wherein said data processor differentiates said respiratory flow signal, the polarity of the differentiated signal representing either inspiration or expiration.

19. An apparatus as claimed in any one of claims 12-18, further comprising a first timer to set the first time duration and a second timer to set the second time duration.

20. A controller for a flow generator to supply breathable gas cyclically at an inspiration pressure and at an expiration pressure substantially in synchronism with a patient's respiration, the controller comprising:

(a) a data processor for receiving an input respiration flow signal and for detecting transitions between inspiration and expiration from said flow signal to discriminate between patient inspiration and expiration, and for outputting a control signal to the flow generator to set the inspiration pressure and the expiration pressure;

(b) a first timer to manually adjust or select a first duration commencing from the last transition to inspiration, whereby if said first time duration elapses before the data processor detects a transition to expiration by the patient, the output signal from the data processor causes the flow generator to supply said expiration pressure; and

(c) a second timer to manually adjust or select a second time duration, shorter than or equal to said first time duration, commencing from said last transition to inspiration corresponding to the data processor forcing said flow generator to supply said inspiration pressure until said second time duration elapses even if during said second time duration there is a transition to expiration by the patient.

21. A controller as claimed in claims 20, wherein said first timer is constructed and arranged so as not to be adjusted by the patient.

22. A controller as claimed in any one of claims 20 and 21, wherein said data processor periodically updates said first time duration based on one or more subsequent respiratory transitions to expiration and whether the first time duration elapses before one or more of said subsequent transitions occur to converge the elapse of said first time duration with said subsequent transitions to expiration.

23. The controller as claimed in any one of claims 20-22, wherein said data processor differentiates said respiratory flow signal, the polarity of the differentiated signal representing either inspiration or expiration.

24. A controller as claimed in any one of claims 20-23, wherein said second timer is patient adjustable with respect to said second time duration.

25. A flow generator for supplying breathable gas cyclically at an inspiration pressure and an expiration pressure substantially in synchronism with a patient's respiration, the flow generator comprising:

a turbine to pressurize inlet breathable gas;

a variable speed electric motor to control operation of said turbine and thus the pressure of breathable gas delivered by the turbine; and

a controller comprising:

(a) a data processor for receiving an input respiration flow signal and for detecting transitions between inspiration and expiration from said flow signal to discriminate between patient inspiration and expiration, and for outputting a control signal to the flow generator to set the inspiration pressure and the expiration pressure;

(b) a first timer to manually adjust or select a first time duration commencing from the last transition to inspiration, whereby if said first time duration elapses before the data processor detects a transition to expiration by the patient, the output signal from the data processor causes the flow generator to supply said expiration pressure; and

(c) a second timer to manually adjust or select a second time duration, shorter than or equal to said first time duration, commencing from said last transition to inspiration corresponding to the data processor forcing supply of inspiration pressure until said second time duration elapses even if during said time duration there is a transition to expiration by the patient.

26. The flow generator of claim 25, further comprising a housing within which are located said turbine, said electric motor and said controller, and further wherein said first timer includes a control device by which said first time duration can be set, the control device being constructed and arranged so as to not be adjusted by a patient.

27. An apparatus for the supply of breathable gas cyclically at an inspiratory pressure and an expiration pressure substantially in synchronism with a patient's respiration, the apparatus comprising:

a turbine to pressurize inlet breathable gas;

a variable speed electric motor to control operation of said turbine and thus the pressure of breathable gas delivered by the turbine;

a gas delivery system coupled to the turbine and providing said breathable gas to the patient's airway;

a flow sensor located in said gas delivery system to provide a respiration flow signal therefrom; and

a controller comprising:

(a) a data processor for receiving said respiration flow signal and for detecting transitions between inspiration and expiration from said flow signal to discriminate between patient inspiration and expiration, and for outputting a control signal provided to the motor to set the inspiration pressure and the expiration pressure;

(b) a first timer to manually adjust or select a first time duration commencing from the last transition to inspiration, whereby if said

first time duration elapses before the data processor detects a transition to expiration by the patient, the output signal from the data processor causes the flow generator to supply said expiration pressure; and

(c) a second timer to manually adjust or select a second time duration, shorter than or equal to said first time duration, commencing from said last transition to inspiration corresponding to the data processor forcing said flow generator to supply said inspiration pressure until said second time duration elapses even if during said second duration there is a transition to expiration by the patient.

28. The apparatus as claimed in claim 27, wherein said gas delivery system comprises a nose mask coupled to a flexible conduit.

29. The apparatus as claimed in claims 27 or 28, further comprising a housing within which are located said turbine, said electric motor and said controller, and further wherein said first timer includes a control device by which said first time duration can be set, the control device being constructed and arranged so as not to be adjusted by a patient.

30. The apparatus as claimed in any one of claims 27 and 29, wherein said gas delivery system comprises a face mask coupled to a flexible conduit.

31. The apparatus as claimed in claims 27 to 30, wherein said first timer is constructed and arranged so as not to be adjusted by the patient.

32. The apparatus as claimed in any one of claims 27 to 31, wherein said data processor periodically updates said first time duration based on one or more subsequent respiratory transitions to expiration and whether the first time duration elapses before one or more of said subsequent

transitions occur to converge the elapse of said first time duration with said subsequent transitions to expiration.

33. The apparatus as claimed in any one of claims 27 to 32, wherein said data
5 processor differentiates said respiratory flow signal, the polarity of the differentiated signal representing either inspiration or expiration.

34. In an assisted respiration apparatus having a controller for a flow generator for
supplying breathable gas to a gas delivery system providing the breathable gas to a
10 patient's airways, and a flow sensor in communication with said gas delivery system,
the controller comprising:

signal processing means for receiving an input gas delivery flow signal and for
discriminating transitions between patient inspiration and expiration based on said flow
signal;

15 first timer means for measuring a first time duration commencing from the last
transition to inspiration by the patient;

logic means for outputting one or more control signals to the flow generator to
designate an inspiration pressure or an expiration pressure produced by said flow
generator, wherein the flow generator is caused to cyclically output a predetermined
20 inspiration pressure and a predetermined expiration pressure substantially in
synchronism with a patient's respiration;

wherein, if said first time duration becomes greater than a variable maximum
IPAP time-out before the signal processing means detects a transition to expiration by
the patient, the logic means is operable to output a signal that causes the flow generator
25 to supply said expiration pressure; and

wherein said variable maximum IPAP time-out is automatically incremented or
decremented by said logic unit during one or more subsequent respiration cycles of the
patient so as to become closer in duration to an inspiratory time of said patient,
whereby a synchronism with the patient's respiration is achieved.

35. An assisted respiration apparatus as claimed in claim 34, wherein for each IPAP/EPAP respiration cycle the logic unit means is operable to automatically produce an incremental increase or decrease to update the variable maximum IPAP time-out whenever said variable maximum IPAP time-out is exceeded by said first timer means and there has been no detection of a transition to expiration, such that an updated IPAP time-out becomes closer in duration to a prevailing period of inspiration of the patient, whereby a change to said expiration pressure is made to occur substantially in synchronism with the patient's respiration.

36. An assisted respiration apparatus as claimed in either of claims 34 or 35, wherein said variable maximum IPAP time-out is at least initially adjustable via user control input means.

37. An assisted respiration apparatus as claimed in any of claims 34 through 36, wherein said variable maximum IPAP duration is automatically incremented towards a maximum time-out limit specified by a first storage unit or decremented towards a minimum time-out limit specified by a second storage unit.

38. An assisted respiration apparatus as claimed in any of claims 34 through 37, wherein the signal processing means is operable to discriminate an exhalation-to-inhalation transition based on a predetermined inhalation threshold value of the time rate of change of said flow signal.

39. An assisted respiration apparatus as claimed in any of claims 34 through 37, wherein the signal processing means is operable to discriminate an inhalation-to-exhalation transition based on a

predetermined exhalation threshold value of the time rate of change of said flow signal.

40. An assisted respiration apparatus as claimed in any of claims 34 through 37, wherein the signal processing means includes a first comparator for comparing a time rate of change of said flow signal to an inhalation threshold value.

41. An assisted respiration apparatus as claimed in claim 40, wherein the first comparator provides an inhalation detection signal to a counter for determining a duration of said detection signal.

42. An assisted respiration apparatus as claimed in any of claims 40 or 41, wherein the signal processing means includes a second comparator for comparing a time rate of change of said flow signal to an exhalation threshold value.

43. An assisted respiration apparatus as claimed in claim 42, wherein the second comparator provides a signal to the logic unit indicating a transition to expiration if said time rate of change of said flow signal exceeds the exhalation threshold value.

44. An assisted respiration apparatus as claimed in any of claims 34 through 39, wherein the signal processing means includes a comparing means for comparing an inspiration duration with said variable maximum IPAP time-out provided by said logic unit for providing automatic adjustment of said variable maximum IPAP time-out.

45. An assisted respiration apparatus as claimed in any of claims 34 through 44, wherein the first timer means comprises a counter which is reset at a transition to expiration.

46. An assisted respiration apparatus as claimed in any of claims 36 through 45, wherein an exhalation threshold value is set via said user control input means.
47. An assisted respiration apparatus as claimed in any of claims 38 through 46,
5 wherein the inhalation threshold value is set via said control input means.
48. An assisted respiration apparatus as claimed in any of claims 34 through 47, wherein the signal processing means is a band limited differentiator.
- 10 49. An assisted respiration apparatus as claimed in any of claims 34 through 48, wherein the controller includes a low pass filter and a high pass filter coupled at an input of said signal processing means for eliminating noise and non-respiratory components from said flow signal.
- 15 50. An assisted respiration apparatus as claimed in claim 34, further comprising a second timer means for timing a minimum IPAP time duration commencing from a transition to inspiration by the patient, wherein said logic means gives precedence to the signal provided by the second timer means ignoring any resetting of the first timer means until the minimum IPAP duration has elapsed.
- 20 51. An assisted respiration apparatus as claimed in claim 50, wherein a minimum IPAP time duration is set via said user control input means.
- 25 52. An assisted respiration apparatus as claimed in claim 34, wherein the signal processing means includes an inhalation threshold reference unit.

53. An assisted respiration apparatus as claimed in either claim 34 or 51, wherein the signal processing means includes an exhalation threshold reference unit.

54. An assisted respiration apparatus as claimed in either claim 34 or 43, wherein
5 the signal processing means includes a minimum time-out value storage unit and a maximum time-out value storage unit for providing minimum and maximum IPAP duration limits to said logic unit.

55. In an assisted respiration apparatus having a controller for a flow generator for
10 supplying breathable gas to a gas delivery system providing the breathable gas to a patient's airways, and a flow sensor in communication with said gas delivery system, the controller comprising:

15 signal processing means for receiving an input gas delivery flow signal and for discriminating transitions between patient inspiration and expiration based on said flow signal;

logic means for outputting one or more control signals to the flow generator to designate an inspiration pressure or an expiration pressure produced by said flow generator, wherein the flow generator is caused to cyclically output a predetermined inspiration pressure and a predetermined expiration pressure substantially in
20 synchronism with a patient's respiration;

wherein the signal processing means is operable to discriminate a transition of a patient's respiration from inhalation-to-exhalation or from exhalation-to-inhalation based on a predetermined threshold value of a time rate-of-change of said flow signal.

25 56. In an assisted respiration apparatus having a flow generator supplying breathable gas to a patient cyclically at an inspiration pressure and at an expiration pressure substantially in synchronism with a patient's respiration, the flow generator comprising:

pressurizing means operable to pressurize inlet breathable gas and deliver a controlled outlet pressure of breathable gas;

a controller receiving an input respiratory flow signal and operable to detect transitions between inspiration and expiration from said flow signal to discriminate
5 between the patient inspiration and expiration, and for outputting a control signal to cause the pressurizing means to output a predetermined inspiration pressure and a predetermined expiration pressure cyclically and substantially in synchronism with a patient's respiration, and further operable to measure a first time duration commencing
10 from the last transition to inspiration, wherein an inspiration time-out duration is set via user control input means, and if said first time duration becomes greater than said inspiration time-out duration before the signal processing means detects a transition to expiration by the patient, the controller is operable to output a signal that causes the flow generator to supply said predetermined expiration pressure; and

wherein the controller is operable to discriminate an exhalation-to-inhalation
15 transition based on a predetermined inhalation threshold value of a time rate of change of said flow signal and is further operable to discriminate an inhalation-to-exhalation transition based on a predetermined exhalation threshold value of a time rate of change of said flow signal.

20 57. An assisted respiration apparatus as claimed in any one of claims 55 or 56, wherein the controller is operable to provide separate and independent detection of both transition to inspiration and transition to expiration by the patient.

58. An assisted respiration apparatus as claimed in any one of claims 55 to 57,
25 wherein the controller is operable to provide automatic adjustment of a maximum IPAP duration time-out duration.

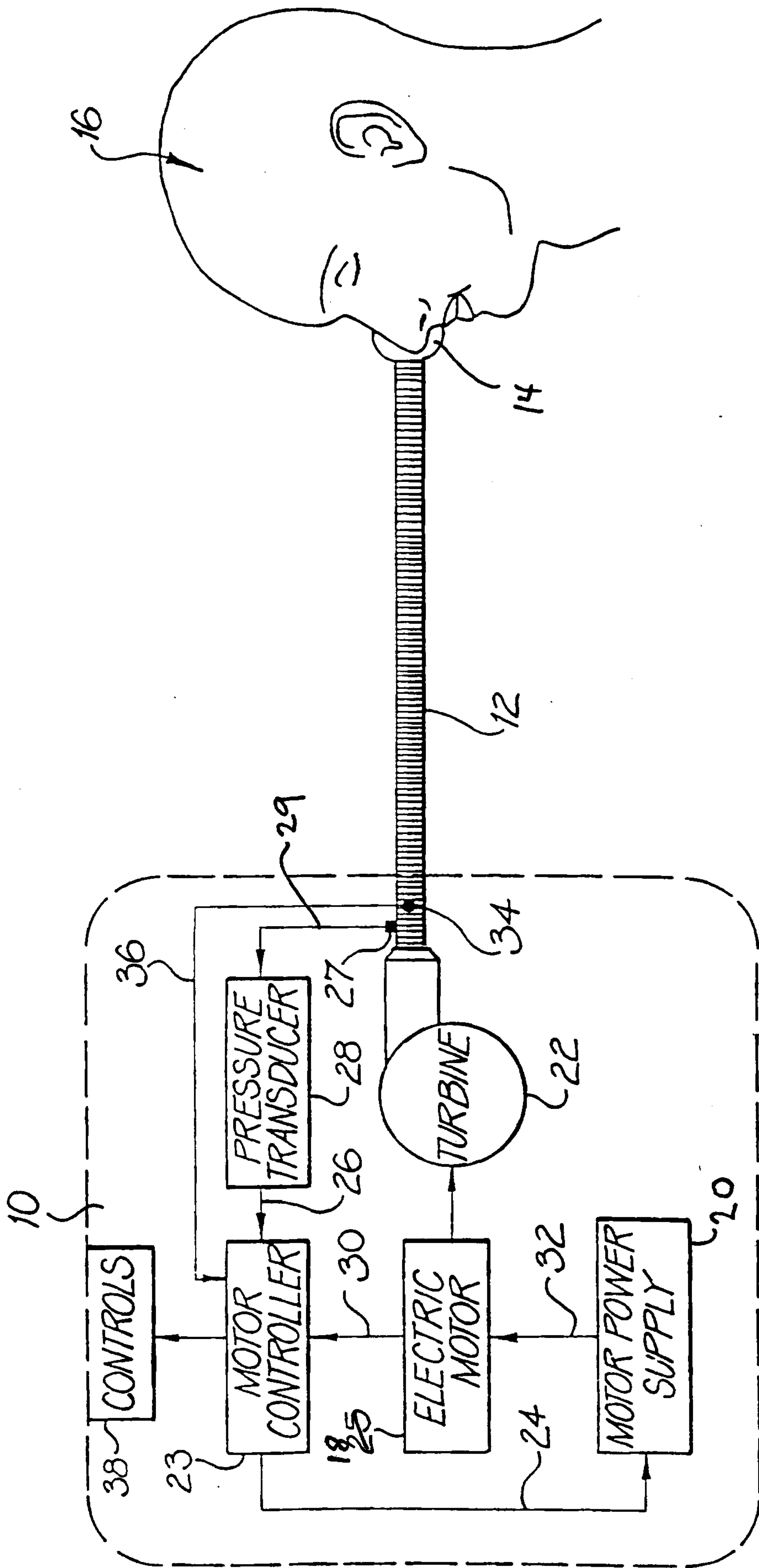

FIG. 1

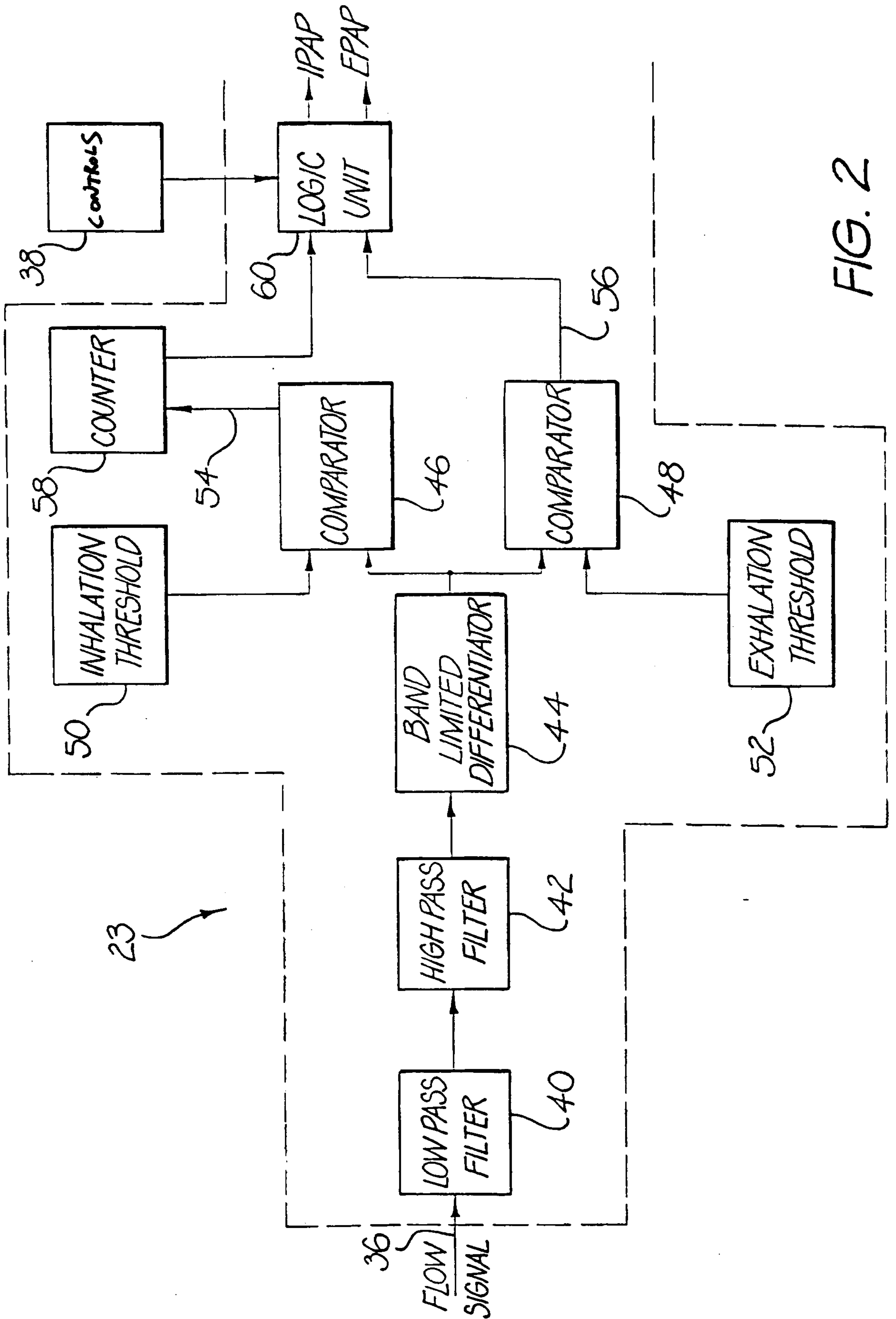

FIG. 2

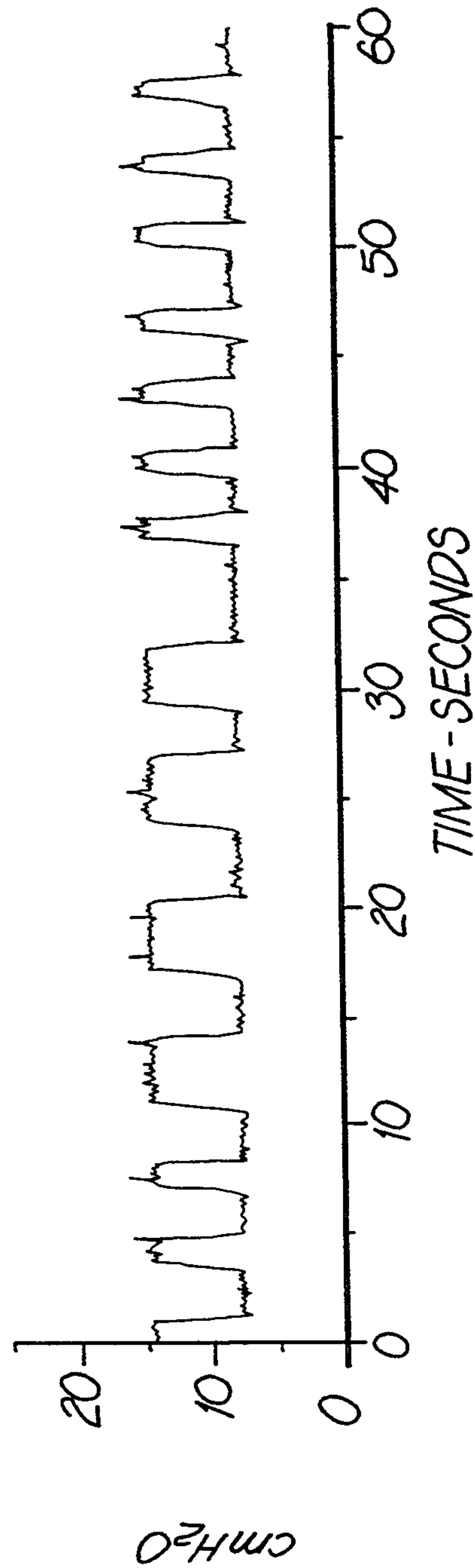
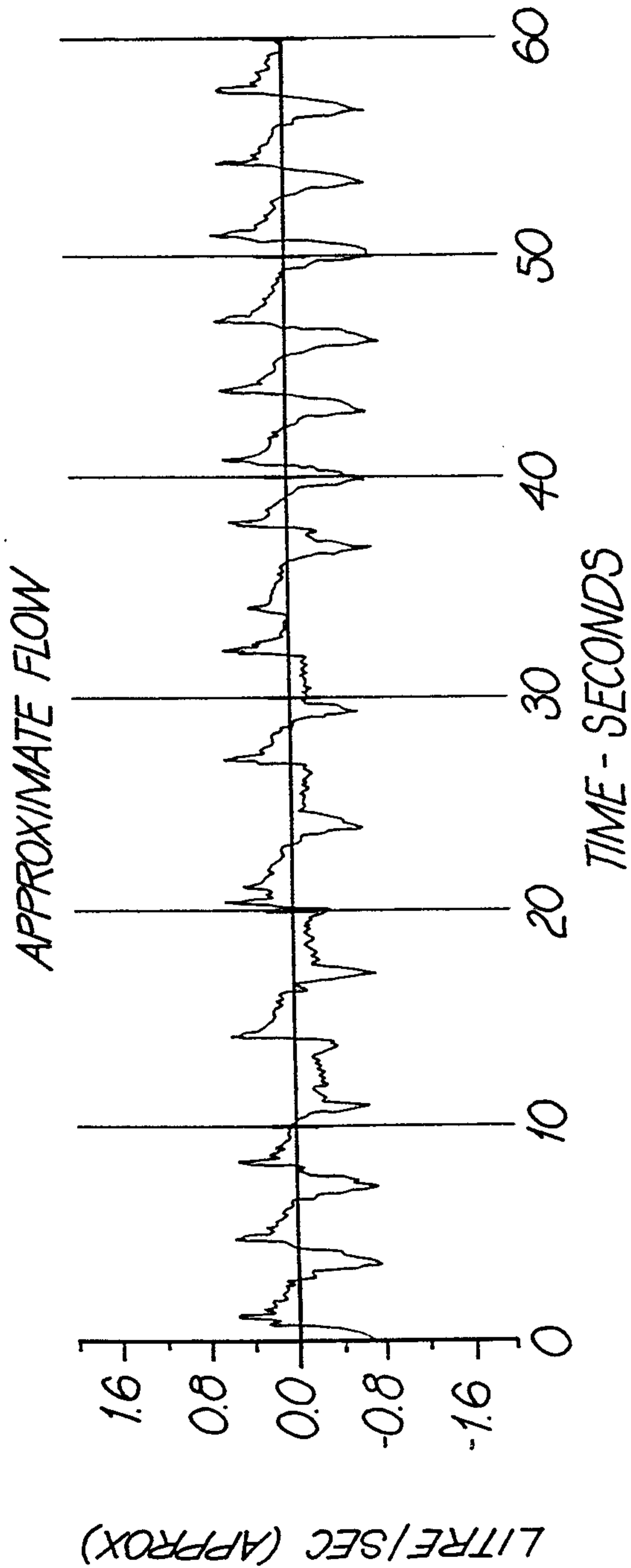



FIG. 4a

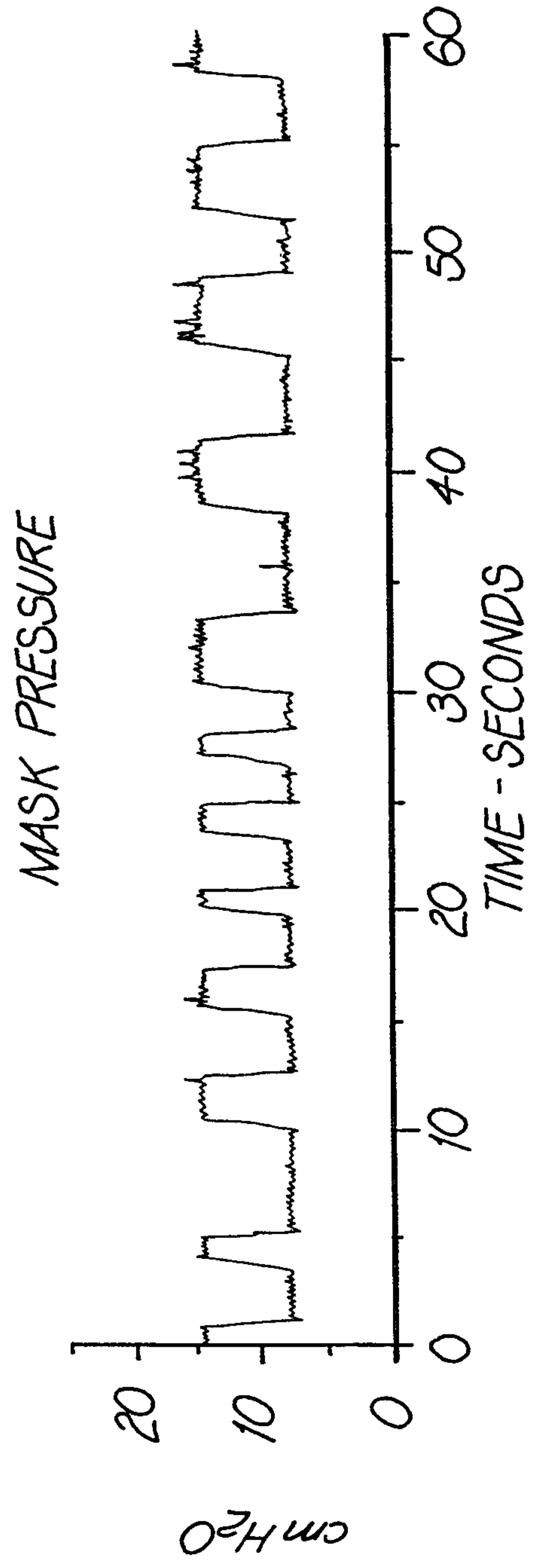
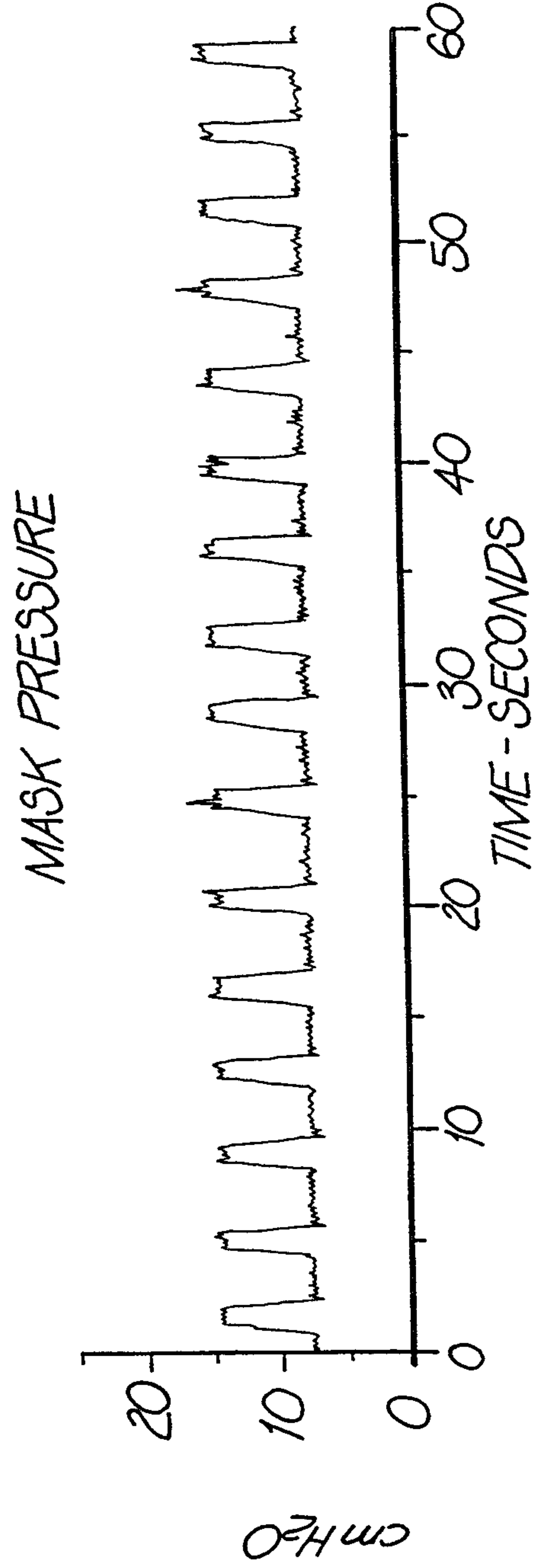
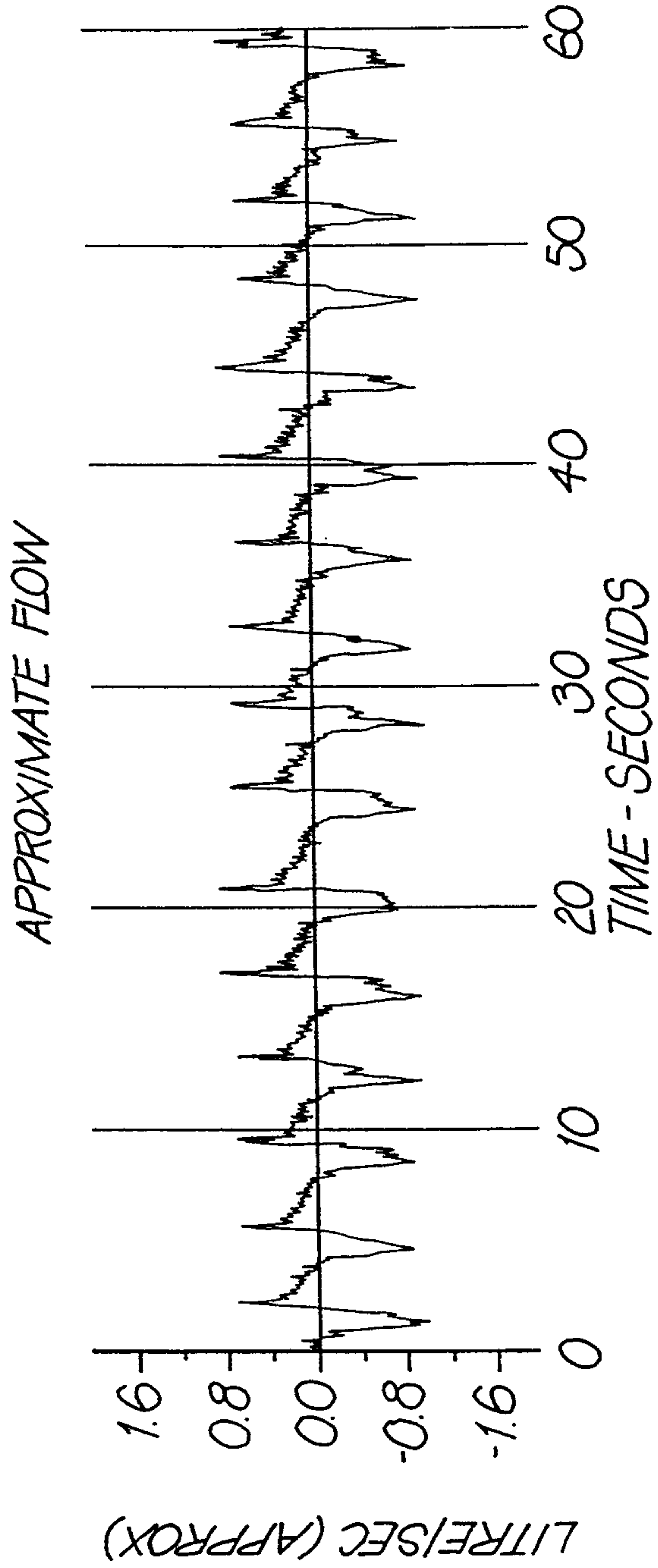
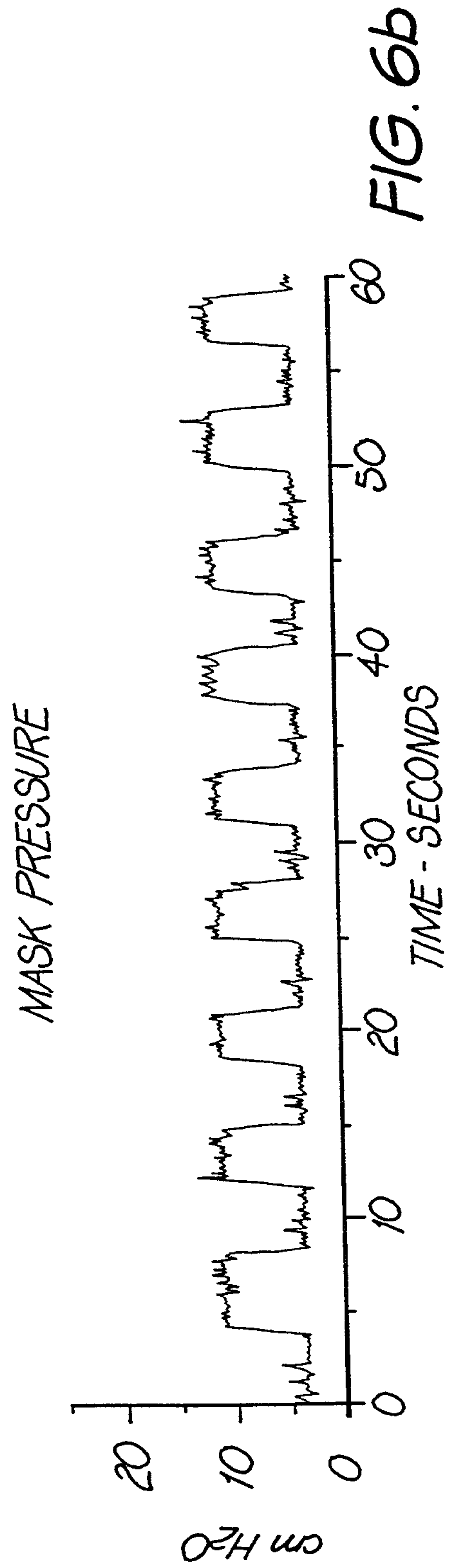
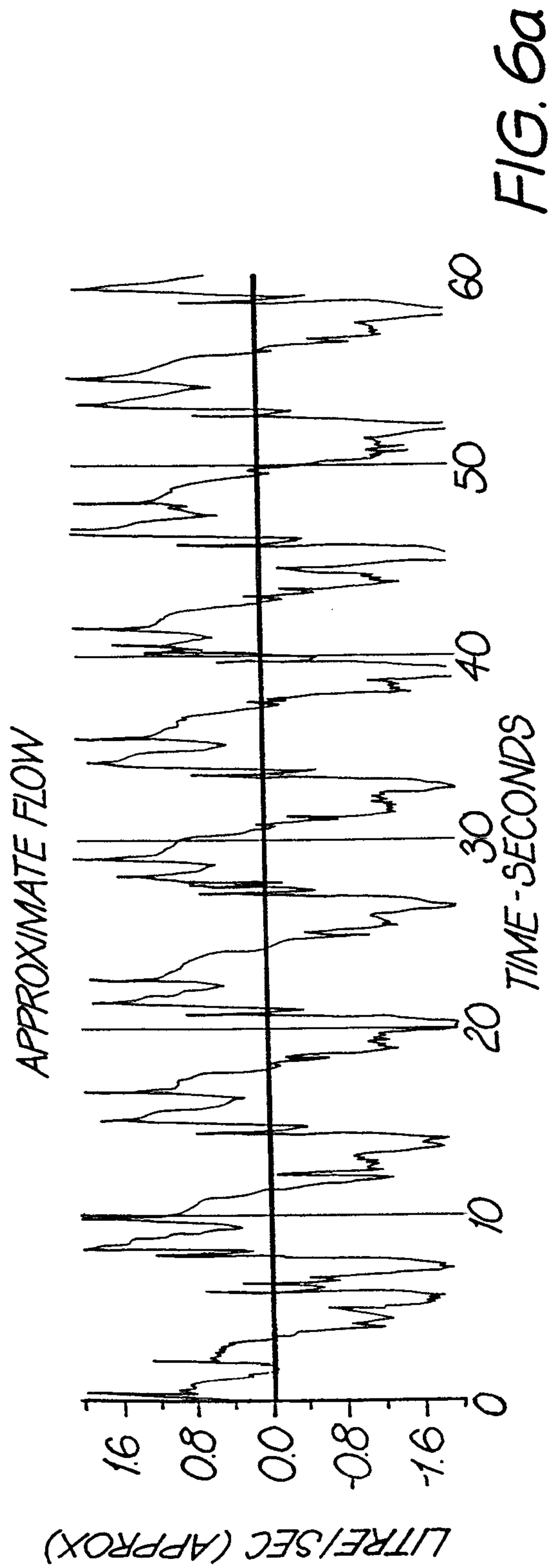
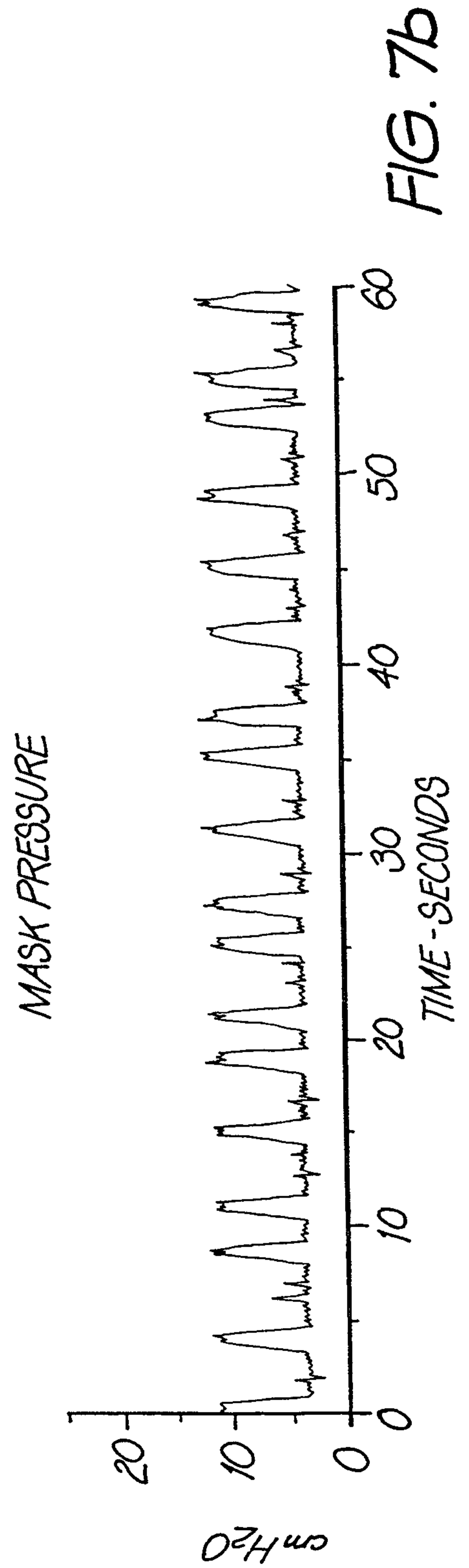
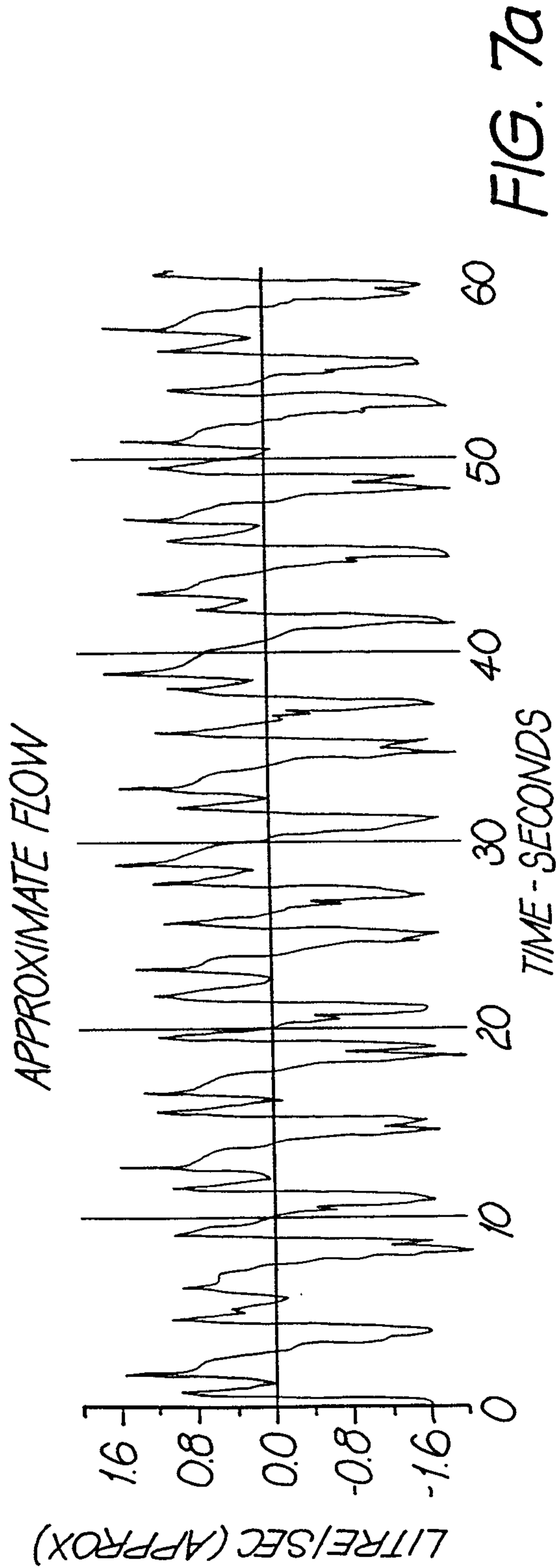

FIG. 4b





7/11



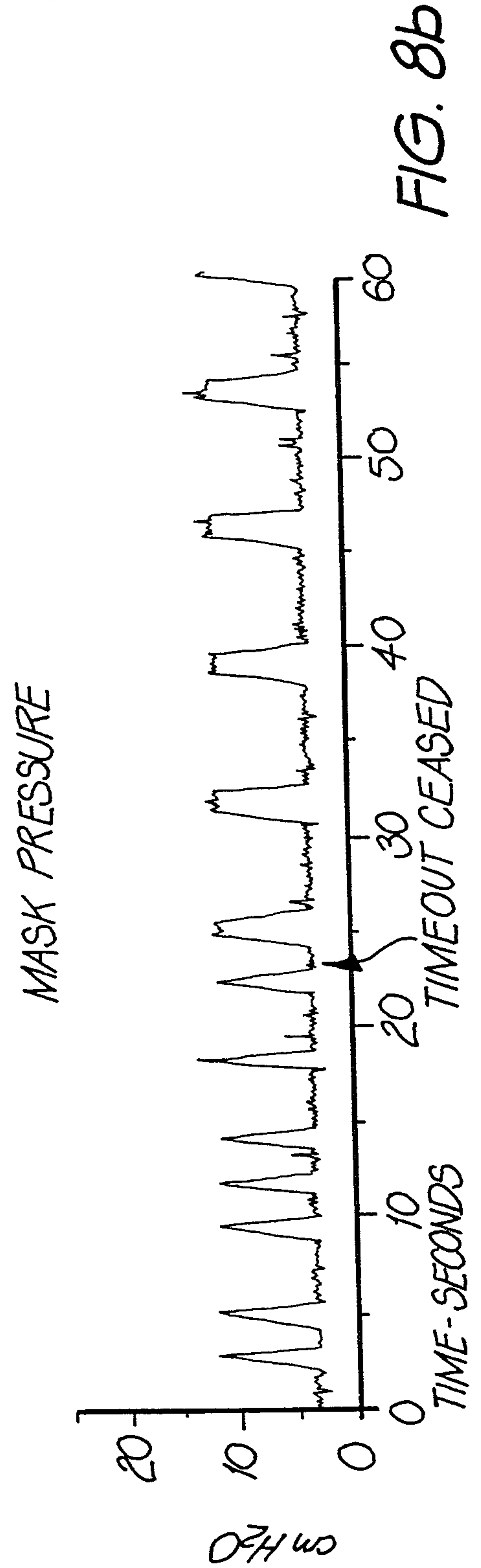
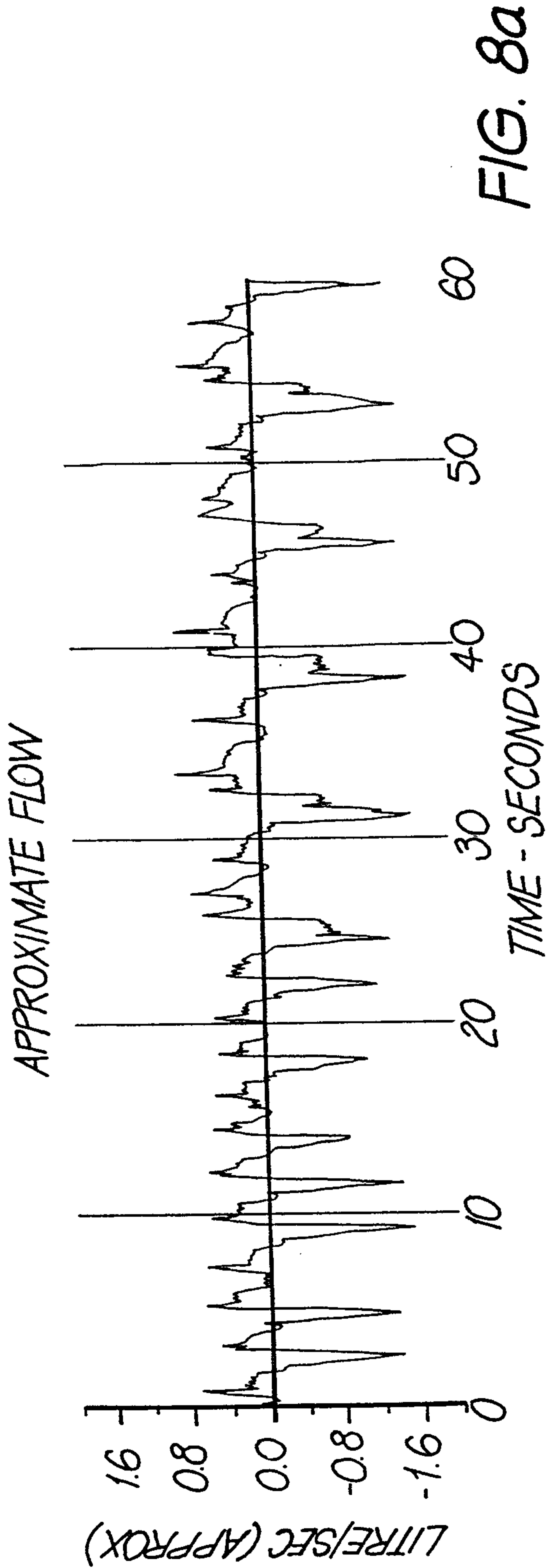

9/11

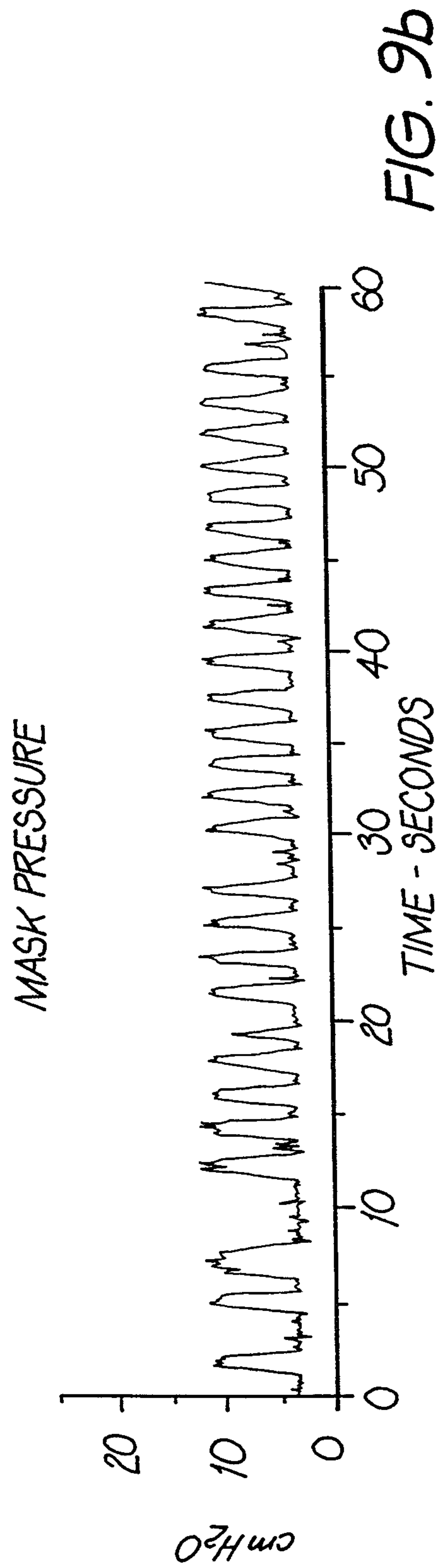
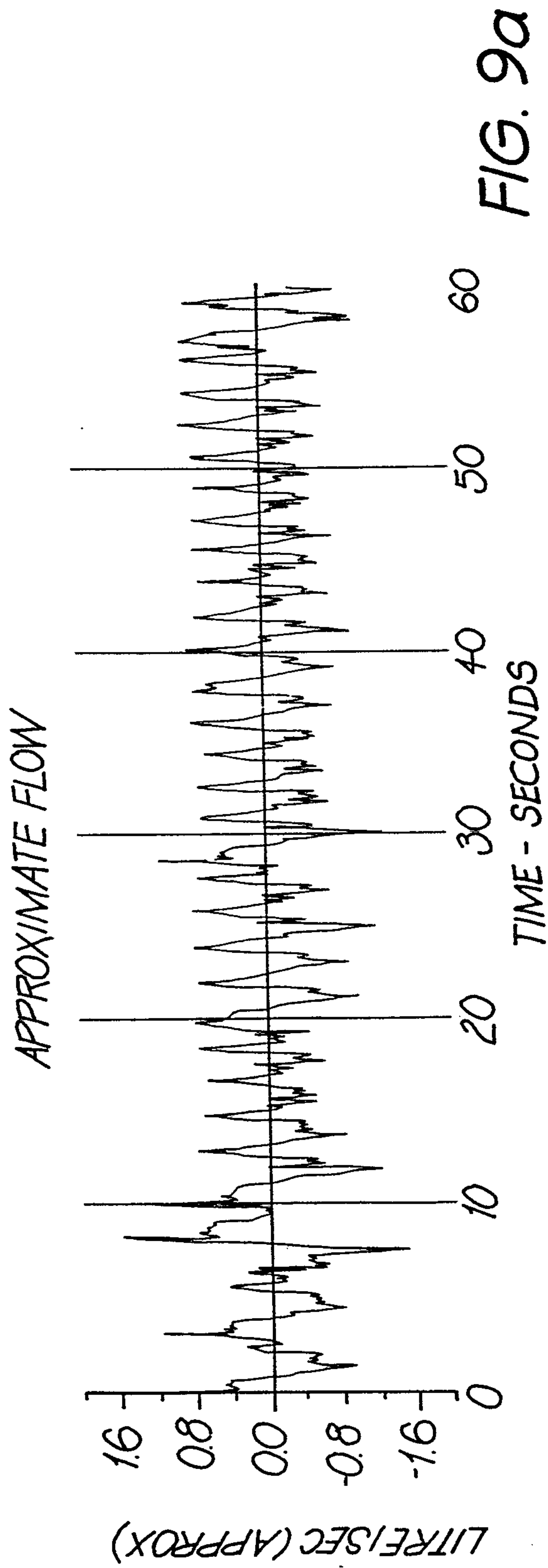

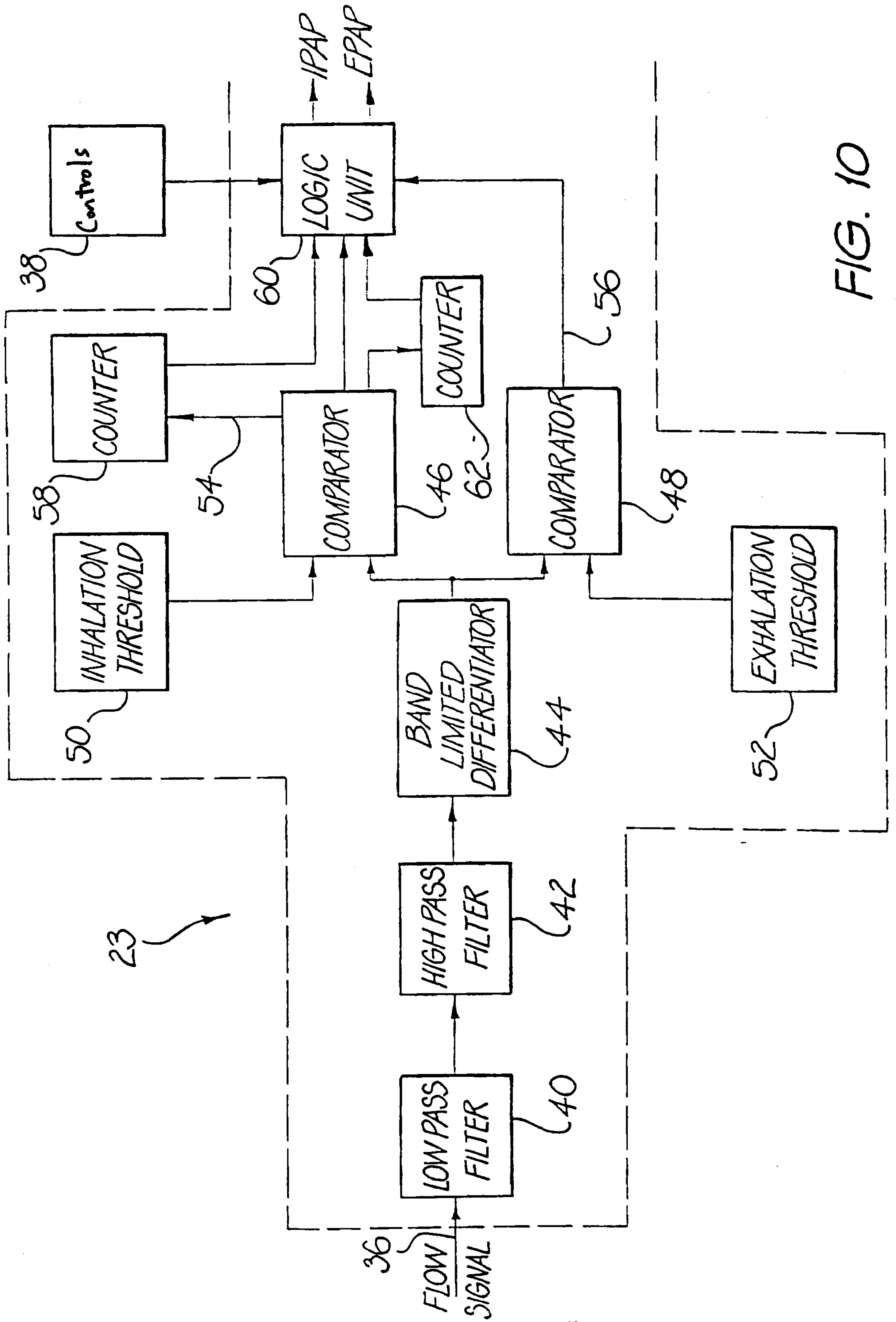

FIG. 10

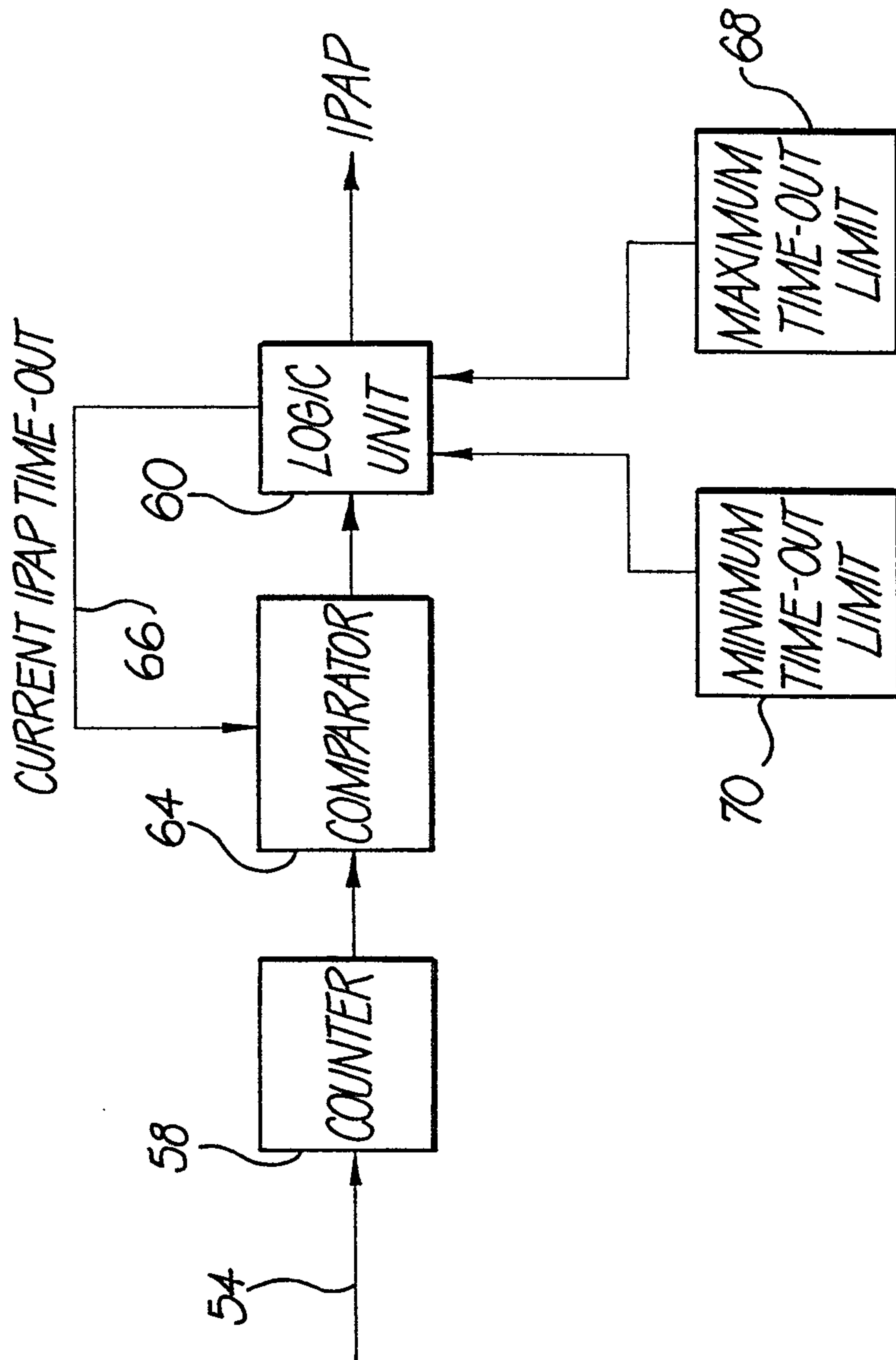

FIG. 11

