

Nov. 27, 1934.

W. L. McGRATH

1,982,114

CONTROLLING MECHANISM FOR INTERNAL COMBUSTION ENGINES

Original Filed Dec. 4, 1931

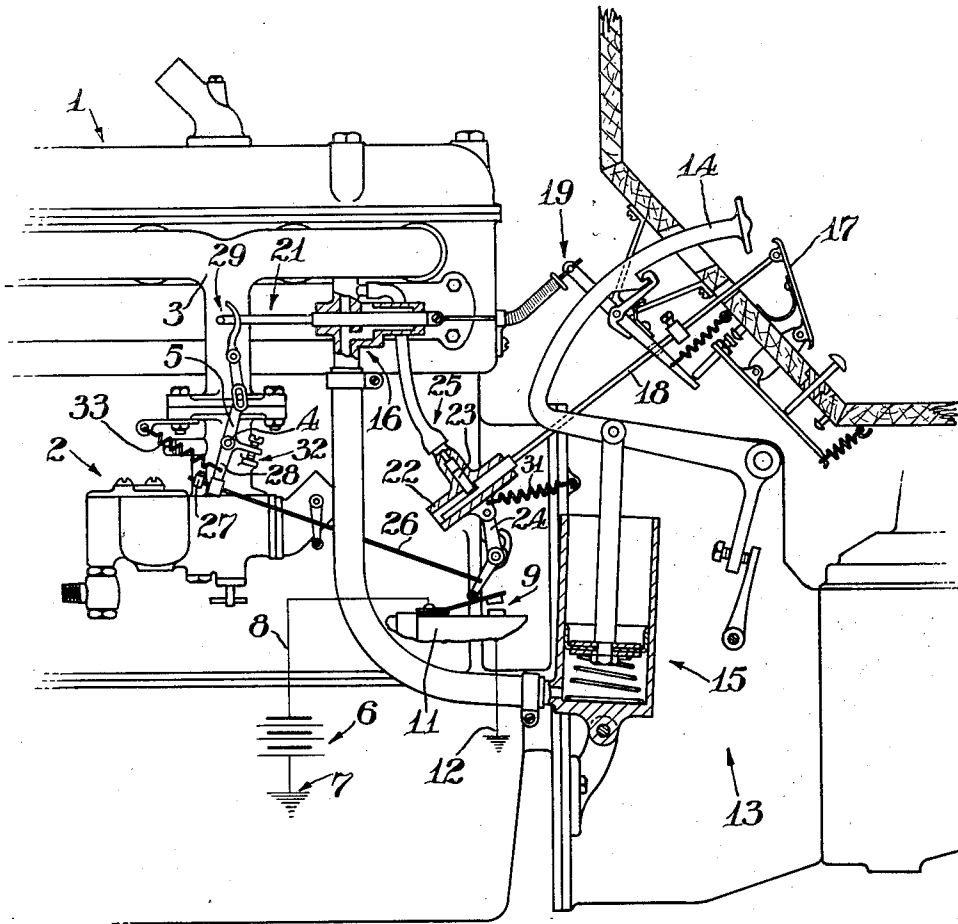

WITNESS

Burr W. Jones

BY

INVENTOR
William L. McGrath
Clinton S. Jones
ATTORNEY

UNITED STATES PATENT OFFICE

1,982,114

CONTROLLING MECHANISM FOR INTERNAL COMBUSTION ENGINES

William L. McGrath, Elmira, N. Y., assignor to Eclipse Machine Company, Elmira, N. Y., a corporation of New York

Original application December 4, 1931, Serial No. 579,068. Divided and this application August 22, 1932, Serial No. 629,984

3 Claims. (Cl. 123—179)

This invention relates to controlling mechanism for internal combustion engines and more particularly to an auxiliary throttle control for use in conjunction with a semi-automatic starting mechanism.

The present invention is a division of my previous application, Serial Number 579,068, filed December 4, 1931, relating to a power controlling system in which a unitary manually operable member is arranged to control the actuation of the starting mechanism, the admission of fuel to the engine, and the clutch for connecting the engine to its load, and pertains more particularly to the arrangement therein disclosed whereby independent means are provided for moving the engine throttle to starting position when the starting mechanism is actuated.

It is an object of the present invention to provide novel controlling mechanism adapted to facilitate the operation of starting an internal combustion engine.

Another object is to provide such a device for use in conjunction with an automatic clutch pedal and starter control from the accelerator pedal of the engine.

A further object is to provide such a device in which an engine controlling element, and more particularly the engine throttle is automatically placed in suitable position for starting simultaneously with the actuation of the starting mechanism.

Further objects and advantages will be apparent to those skilled in this art from the following description taken in connection with the accompanying drawing in which the figure is a partially diagrammatic illustration in side elevation of a preferred embodiment of the invention, certain of the parts being shown broken away and in section.

In the drawing there is illustrated an internal combustion engine indicated generally by numeral 1, having a fuel intake system including a carburetor 2 mounted on an intake manifold 3 and having a fuel controlling element in the form of a throttle of the usual type mounted on a shaft 4 and arranged to be operated by a lever 5.

An electrical starting system for the engine 1 is illustrated including a battery 6, grounded at 7 and connected by a lead 8 to a starting switch 9 mounted on a starting motor 11 which is grounded at 12 to complete the motor circuit.

Means are provided for applying the load to the engine such as a clutch, not illustrated, located within the casing 13 and arranged to be operated by a clutch pedal 14.

Power operating means for the clutch pedal 14 are provided in the form of a servo mechanism indicated generally at 15 and actuated by intake vacuum under the control of a valve mechanism 16, but since this structure does not form part of the present invention, a particular description thereof is deemed unnecessary.

A manually operable member in the form of an accelerator pedal 17 is arranged to control the valve mechanism 16 by means of a rod 18 and a mechanical connection indicated generally at 19, and is adapted to control the position of the throttle lever 5 by means of a further mechanical connection indicated generally at 21. The rod 18 is also adapted to control the energization of the starting mechanism by means of a connection including a cylindrical member 22 normally connected to said rod by a slidable latch 23 and pivoted to a bell crank lever 24 which is arranged to close the starting switch 9 upon depression of the accelerator pedal 17 when the latch 23 is in operative position.

Means are provided for disabling the connection between the accelerator pedal 17 and starting switch 9 by withdrawing the latch 23, in the form of a vacuum control indicated generally at 25 whereby when the engine is running intake vacuum maintains the latch 23 in its inoperative position.

According to the present invention, means are provided independent of the throttle operating mechanism above described for moving the throttle to proper position for starting when the starting system is energized. As here illustrated, this means is in the form of a link 26 connected at one end to the bell crank lever 24 and at its other end provided with an adjustable stop 27 adapted to engage an arm 28 on the throttle lever 5 and move said lever to adjust the throttle to proper condition for starting. In order not to interfere with this operation, a lost motion connection 29 is provided in the throttle controlling connection.

It will be understood that the abutment 27 is to be adjusted on the link 26 in order to secure the proper throttle opening for starting purposes when the lever 24 has been moved to close the starting switch 9.

In the operation of this device, depression of the manually operable member 17 when the engine is stopped is transmitted through the rod 18, latch 23, cylindrical member 22 and lever 24 to close the starting switch 9 whereby the starting mechanism is energized. This motion of lever 24 is transmitted by link 26 to swing the throt-

tle shaft 4 and move the throttle to a partially open position suitable for starting the engine.

When the engine starts, the latch 23 is withdrawn by the intake vacuum, disconnecting the lever 24 from the rod 18, whereupon the lever is returned to its idle position by suitable means such as a spring 31. The throttle shaft 4 is thereupon returned to its idling position as defined by a suitable stop 32 by suitable means such as a spring 33.

Although but one form of the invention has been shown and described in detail, it will be understood that other forms are possible and that various changes may be made in the construction and relation of the parts without departing from the spirit of the invention as defined in the claims appended hereto.

What is claimed is:

1. In combination with an internal combustion engine having a fuel intake system including a throttle, a starting system for said engine, a manually operable member, means for controlling said throttle from said manually operable member, means whereby actuation of the manually operable member when the engine is stopped energizes the starting system, and means operated by said latter means, independent of said means for controlling the throttle, for automatically placing the throttle in starting position when the starting mechanism is actuated.

2. In combination with an internal combustion engine having a fuel supply system including a throttle, a starting system for said engine, means including a manual member for controlling said throttle, means whereby initial actuation of the manual control member when the engine is stopped actuates the starting system, means rendered effective by said last mentioned means whereby such actuation of the manual control member partially opens said throttle, and means whereby self-operation of the engine disables the starter actuating means and said throttle opening means.

3. In combination with an internal combustion engine having a fuel supply system including a throttle, a starting system for said engine, a manually operable member, means for controlling said throttle from said manually operable member, means whereby actuation of the manually operable member when the engine is stopped energizes the starting system, means operated by said latter means independent of said controlling means for moving the throttle to starting position when the starting system is energized and means whereby self-operation of the engine disables the starter energizing means and said independent means for moving the throttle.

WILLIAM L. McGRATH.

35

40

45

50

55

60

65

70

75

80

85

90

95

100

105

110

115

120

125

130

135

140

145

150