



- (51) International Patent Classification:
A61B 17/92 (2006.01)
- (21) International Application Number:
PCT/US2018/024934
- (22) International Filing Date:
28 March 2018 (28.03.2018)
- (25) Filing Language: English
- (26) Publication Language: English
- (30) Priority Data:
62/599,616 15 December 2017 (15.12.2017) US
- (71) Applicant: COREX, LLC [US/US]; 501 James Robertson
Parkway, Nashville, Tennessee 37219 (US).
- (72) Inventor: PEDICINI, Christopher; 3015 Lockwood
Ridge Lane, Franklin, Tennessee 37064 (US).
- (74) Agent: GARDELLA, Greg H. et al.; 455 Massachusetts
Ave, NW, Suite 507, Washington, District of Columbia
20001 (US).
- (81) Designated States (unless otherwise indicated, for every
kind of national protection available): AE, AG, AL, AM,
AO, AT, AU, AZ, BA, BB, BG, BH, BN, BR, BW, BY, BZ,
CA, CH, CL, CN, CO, CR, CU, CZ, DE, DJ, DK, DM, DO,
DZ, EC, EE, EG, ES, FI, GB, GD, GE, GH, GM, GT, HN,
HR, HU, ID, IL, IN, IR, IS, JO, JP, KE, KG, KH, KN, KP,
KR, KW, KZ, LA, LC, LK, LR, LS, LU, LY, MA, MD, ME,
MG, MK, MN, MW, MX, MY, MZ, NA, NG, NI, NO, NZ,
OM, PA, PE, PG, PH, PL, PT, QA, RO, RS, RU, RW, SA,
SC, SD, SE, SG, SK, SL, SM, ST, SV, SY, TH, TJ, TM, TN,
TR, TT, TZ, UA, UG, US, UZ, VC, VN, ZA, ZM, ZW.
- (84) Designated States (unless otherwise indicated, for every
kind of regional protection available): ARIPO (BW, GH,
GM, KE, LR, LS, MW, MZ, NA, RW, SD, SL, ST, SZ, TZ,
UG, ZM, ZW), Eurasian (AM, AZ, BY, KG, KZ, RU, TJ,

(54) Title: ORTHOPEDIC ADAPTER FOR AN ELECTRIC IMPACTING TOOL

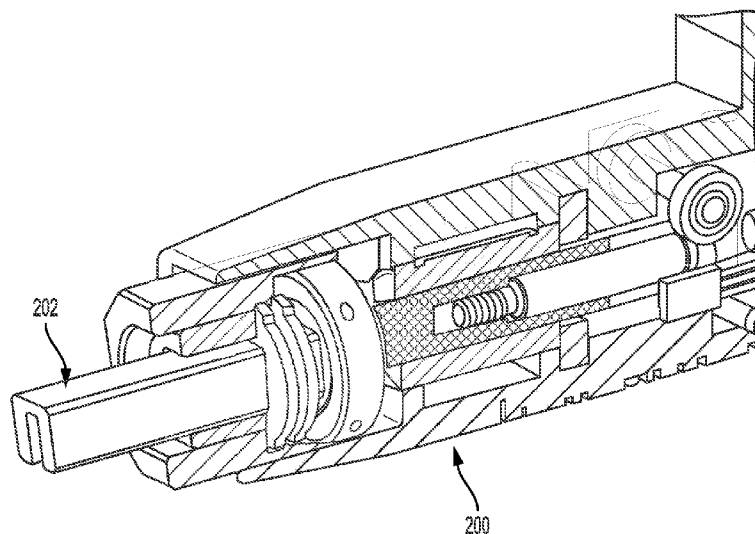

FIG. 2A

(57) Abstract: An electrically driven orthopedic impactor may include an adapter for interfacing between the adapter and a surgical implement. The adapter may have a first surface that transmits a forward impact energy and a second surface that transmits a reverse impact energy. The adapter can connect to the surgical implement and to the orthopedic impactor without the use of external tools. The adapter may connect to the impactor via a pushing motion and may disconnect from the impactor via a reciprocal sleeve. A sensor can communicate a spatial orientation of the adapter with respect to at least one reference point that is not located on the adapter or the impactor. A communication device may transmit frequency information or impact energy information to the impactor based on a type of surgical implement attached to the adapter.



TM), European (AL, AT, BE, BG, CH, CY, CZ, DE, DK, EE, ES, FI, FR, GB, GR, HR, HU, IE, IS, IT, LT, LU, LV, MC, MK, MT, NL, NO, PL, PT, RO, RS, SE, SI, SK, SM, TR), OAPI (BF, BJ, CF, CG, CI, CM, GA, GN, GQ, GW, KM, ML, MR, NE, SN, TD, TG).

Published:

— *with international search report (Art. 21(3))*

ORTHOPEDIC ADAPTER FOR AN ELECTRIC IMPACTING TOOL

RELATED APPLICATIONS

[0001] This application claims priority to U.S. Provisional Patent Application Serial No. 62/599,616, entitled "Orthopedic Adapter for an Electric Impacting Tool," filed December 15, 2017. This application is related to the following prior patent applications directed to Orthopedic Impacting Devices: U.S. Patent Application Serial No. 12/980,329, entitled "Electric Motor Driven Tool for Orthopedic Impacting," filed December 29, 2010, now U.S. Patent No. 8,695,726; U.S. Patent Application Serial No. 13/466,870, entitled "Electric Motor Driven Tool for Orthopedic Impacting," filed May 8, 2012, now U.S. Patent No. 8,393,409; U.S. Patent Application Serial No. 13/790,870, entitled "Electric Motor Driven Tool for Orthopedic Impacting," filed March 8, 2013, now U.S. Patent No. 8,602,124; U.S. Patent Application Serial No. 14/250,102, entitled "Electric Motor Driven Tool for Orthopedic Impacting," filed April 10, 2014, now U.S. Patent No. 9,901,354; U.S. Patent Application Serial No. 14/332,767, entitled "Electric Motor Driven Tool for Orthopedic Impacting," filed July 16, 2014, now U.S. Patent No. 8,936,105; U.S. Patent Application Serial No. 14/332,790, entitled "Electric Motor Driven Tool for Orthopedic Impacting," filed July 16, 2014, now U.S. Patent No. 8,936,106; U.S. Patent Application Serial No. 14/850,588, entitled "Electric Motor Driven Tool for Orthopedic Impacting," filed September 10, 2015; U.S. Patent Application Serial No. 14/850,620, entitled "Electric Motor Driven Tool for Orthopedic Impacting," filed September 10, 2015; U.S. Patent Application Serial No. 14/850,639, entitled "Electric Motor Driven Tool for Orthopedic Impacting," filed September 10, 2015; U.S. Patent Application Serial No. 14/850,660, entitled "Electric Motor Driven Tool for Orthopedic Impacting," filed September 10, 2015; U.S. Patent Application

Serial No. 14/850,674, entitled "Electric Motor Driven Tool for Orthopedic Impacting," filed September 10, 2015; U.S. Patent Application Serial No. 14/850,695, entitled "Electric Motor Driven Tool for Orthopedic Impacting," filed September 10, 2015; U.S. Patent Application Serial No. 14/992,781, entitled "Electric Motor Driven Tool for Orthopedic Impacting," filed January 11, 2016; U.S. Patent Application Serial No. 15/009,723, entitled "Battery Enclosure for Sterilizeable Surgical Tools Having Thermal Insulation," filed January 28, 2016; U.S. Patent Application Serial No. 15/098,662, entitled "Electric Motor Driven Tool for Orthopedic Impacting," filed April 14, 2016; U.S. Patent Application Serial No. 15/439,692, entitled "Orthopedic Impacting Device Having a Launched Mass Delivering a Controlled, Repeatable & Reversible Impacting Force," filed February 22, 2017; U.S. Patent Application Serial No. 15/446,862, entitled "Orthopedic Impacting Delivering a Controlled, Repeatable Impact," filed March 1, 2017; U.S. Patent Application Serial No. 15/544,317, entitled "Battery Enclosure for Sterilizeable Surgical Tools Having Thermal Insulation," filed July 18, 2017; U.S. Patent Application Serial No. 15/600,234, entitled "Orthopedic Impacting Delivering a Controlled, Repeatable Impact," filed May 19, 2017; U.S. Patent Application Serial No. 15/600,284, entitled "Orthopedic Impacting Device Having a Launched Mass Delivering a Controlled, Repeatable & Reversible Impacting Force," filed May 19, 2017; U.S. Patent Application Serial No. 15/677,933, entitled "Electric Motor Driven Tool for Orthopedic Impacting," filed August 15, 2017; U.S. Patent Application Serial No. 15/789,493, entitled "Orthopedic Impacting Device Having a Launched Mass Delivering a Controlled, Repeatable & Reversible Impacting Force," filed October 20, 2017; and U.S. Patent Application Serial No. 15/857,385, entitled "Electric Motor Driven Tool for Orthopedic Impacting," filed December 28, 2017. All above identified applications are hereby incorporated by reference in their entireties.

BACKGROUND

[0002] The present disclosure relates to adapters for electrically powered surgical impacting tools used in surgical applications such as orthopedic procedures, including procedures using a motor driven tool for bidirectional, surgical impacting that is driven by a launched mass to provide controlled, repeatable impacts to a surgical implement.

[0003] In the field of orthopedics, prosthetic devices, such as artificial joints, are often implanted or seated in a patient's bone cavity. The cavity is typically formed during surgery before a prosthesis is seated or implanted. For example, a physician may remove and or compact existing bone to form the cavity. The prosthesis usually includes a stem or other protrusion that is inserted into the cavity.

[0004] To create the cavity, a physician may use a broach conforming to the shape of the stem of the prosthesis. Solutions known in the art include providing a handle with the broach for manual hammering by the physician during surgery to impel the broach into the implant area. Unfortunately, this approach is crude and notoriously imprecise, leading to unnecessary mechanical stress on the bone. The results can be unpredictable and depend on the skill of a particular physician. Historically, this approach will in many cases result in inaccuracies in the location and configuration of the cavity. Additionally, the surgeon is required to expend an unusual amount of physical force and energy to hammer the broach and to manipulate the bones and prosthesis. Most importantly, this approach carries with it the risk that the physician will cause unnecessary further trauma to the surgical area and damage otherwise healthy tissue, bone structure and the like.

[0005] Another technique for creating the prosthetic cavity is to drive the broach pneumatically, that is, by compressed air. This approach is disadvantageous in that it prevents portability of an impacting tool, for instance, because of the presence of a tethering air-line, air being exhausted from a tool into the sterile operating field and fatigue of the physician

operating the tool. This approach, as exemplified in U.S. Pat. No. 5,057,112, does not allow for precise control of the impact force or frequency and instead functions very much like a jackhammer when actuated. Again, this lack of any measure of precise control makes accurate broaching of the cavity more difficult and can lead to unnecessary patient complications and trauma. These types of tools may produce movements with wide ranges of motion perpendicular to the cutting axis, further inhibiting accuracy and precision. In some instances, such accuracy and precision, or lack thereof, may be quantified by describing the total indicator reading (“TIR”) of the surgical implement connected to the tool’s adapter.

[0006] A third technique relies on computer-controlled robotic arms for creating the cavity. While this approach overcomes the fatiguing and accuracy issues, it suffers from having a very high capital cost and removes the tactile feedback that a surgeon can get from a manual approach. Further unless the approach is by milling, an impacting means (pneumatic, electrical or manual) is still required.

[0007] Other techniques use the inventor’s own work and may include a hammer throwing method which involves a linear compressor, vacuum actuation, or a mechanical or gas spring, all of which are electrically powered. With the hammer throwing method, however, the use of existing commercially available adapters to couple impact energy created by the thrown mass (hammer) or striker from within the electrically driven impactor to a surgical implement has resulted in very poor coupling of the internal energy to the surgical implement, with losses of 50% or greater being typical.

[0008] Consequently, there exists a need for improved adapters between impacting tools and surgical implements that overcome the various disadvantages of existing adapters.

SUMMARY OF ILLUSTRATIVE EMBODIMENTS

[0009] In view of the foregoing disadvantages, adapters are provided for an electric motor-driven orthopedic impacting tool to enable coupling of surgical implements to the tool, which may be provided for orthopedic impacting in hips, knees, shoulders and the like. The adapter is capable of holding a broach, chisel, or other end effector and delivering power from the impactor to gently tap the broach, chisel or other end effector into the cavity with controlled percussive impacts, resulting in a better fit for the prosthesis or the implant. The adapter can also be used in the placement and removal of broaches, implants, cups, liners, head balls, nails, wires, pins, and other devices. Further, the adapter may enable additional control of the electrically driven orthopedic impactor by communicating or otherwise indicating impact settings based on the patient, surgical implement, or surgical procedure. The adapter further enables proper seating and, in the case of bidirectional movement, the removal of the prosthesis or the implant into or out of an implant cavity, and advantageously augments the existing surgeon's skill in guiding the electrically driven orthopedic impactor.

[0010] In order to provide context, a brief description of the electrically driven orthopedic impactor is provided (other similar and related devices are also described in the Related Applications identified above and incorporated by reference herein). An electric motor-driven orthopedic impacting tool includes a power source (such as a battery, fuel cell, or cartridge of compressed gas), a motor assembly, a controller, a housing, a stored-energy system or mechanism such as a gas or mechanical spring capable of storing and releasing potential energy, and a striker energized by the stored-energy drive system to be operational in a forward and/or a rearward direction, where the striker is capable of generating an impact force in either a forward or a rearward direction.

[0011] In an embodiment, an adapter is used to communicate the force between the electrically driven impactor and the surgical implement. In a further embodiment, the adapter

has two distinct surfaces which are used to communicate a forward or reverse impact from the electrically driven impactor (hereafter referred to as tool) to the surgical implement.

[0012] In an embodiment the surgical implement can be combined with the adapter.

[0013] In an embodiment, the adapter communicates at least 50% of the energy of the striker to the surgical implement.

[0014] In an exemplary embodiment, the adapter communicates back to the tool whether the surgeon or robot is either pushing or pulling the adapter and surgical implement towards or away from the patient.

[0015] In a further exemplary embodiment, a surgical implement (e.g., broach, chisel or other end effector) can be rotated to a number of positions while still maintaining axial alignment, as illustrated, for example, in FIG. 2A, where the adapter is rotatable in four different positions, each position rotated by 90°. This facilitates the use of the adapter or broach, for example, in various anatomical presentations during surgery.

[0016] In some embodiments, the adapter is configured to communicate the spatial position of the adapter in relation to the patient. For example, the adapter or the impactor may include a sensor and/or a camera that communicates the relative position and/or alignment of the tool to the patient. This may be accomplished by tracking a reference point associated with the patient and not located on the adapter or the impactor. In a further embodiment, the sensor may be configured to communicate the position of the adapter or impactor in coordination with a surgical navigation system to inform a surgeon or robot of a position in comparison to an optimal position, a planned final position, or any other desired position.

[0017] In an exemplary embodiment, the adapter of the tool includes at least one of two points of impact, a forward striking surface or first surface and a rearward striking surface or second surface.

[0018] In an exemplary embodiment, the anvil and the adapter include a single element, or one may be integral to the other.

[0019] In an exemplary embodiment, the adapter weighs less than the anvil, striker, or other thrown mass of the impactor.

[0020] In an exemplary embodiment, the adapter weighs less than half of the weight of the impactor tool, and preferably less than 40% of the weight of the impactor.

[0021] In an exemplary embodiment, the adapter is substantially axially inline with the anvil, striker, or other thrown mass of the impactor. This has an unexpected benefit in that bone is an anisotropic material, which is strongest with respect to compression forces, then tension, then shear. By keeping the forces inline, operation of the tool will result in lower stress on the bone and yield better outcomes.

[0022] In an exemplary embodiment, the adapter is able to communicate force, frequency, and throw settings back to the tool based on the surgical implement or procedure.

[0023] In an exemplary embodiment, the adapter may include a dampening mechanism such as a viscoelastic material or elastomeric or mechanical spring which limits the total energy communicated from the tool to the surgical implement. The dampener may be chosen or configured to provide any desired capability, such as a particular level of dampening or dampening only in a particular direction. For example, the dampener may reduce the impact energy from the tool by 10% or 50%, preferably at least 20%, and the dampener may only dampen energy in the forward direction, leaving a sharper impact force in the rearward direction.

[0024] In an exemplary embodiment, the adapter may include a mechanism that produces an audible or visual cue that indicates that the adapter is properly connected to the tool. For example, tabs, grooves, raised edges, and other similar features may be configured to snap into place and generate an audible cue upon proper connection of the adapter to the tool or

surgical implement. A visual cue may also show that the adapter is properly connected to the tool or surgical implement. For example, a window or other designated area on the adapter, tool, or surgical implement may display a red color when the adapter is not properly connected and a green color when the adapter is properly connected.

[0025] In an exemplary embodiment, the adapter may be connected to a surgical implement having cutting teeth useful for final shaping of bone prior to placing an implant. In a still further embodiment, the pitch of the cutting teeth (spacing in the direction of impact) is determined to be less than the powered throw of the instrument. In a still further embodiment, it was found to be advantageous to have bidirectional cutting teeth, which allowed for bone shaping on both a forward impact and a rearward impact.

[0026] These, together with other aspects of the present disclosure, along with the various features of novelty that characterize the present disclosure, are pointed out with particularity in the claims annexed hereto and form a part of the present disclosure. For a better understanding of the present disclosure, its operating advantages, and the specific non-limiting objects attained by its uses, reference should be made to the accompanying drawings and detailed description in which there are illustrated and described exemplary embodiments of the present disclosure.

[0027] The forgoing general description of the illustrative implementations and the following detailed description thereof are merely exemplary aspects of the teachings of this disclosure, and are not restrictive.

BRIEF DESCRIPTION OF THE DRAWINGS

[0028] The accompanying drawings, which are incorporated in and constitute a part of the specification, illustrate one or more embodiments and, together with the description, explain these embodiments. The accompanying drawings have not necessarily been drawn to scale.

Any values dimensions illustrated in the accompanying graphs and figures are for illustration purposes only and may or may not represent actual or preferred values or dimensions. Where applicable, some or all features may not be illustrated to assist in the description of underlying features. In the drawings:

- [0029] FIG. 1 illustrates a perspective view of an orthopedic impacting tool;
- [0030] FIG. 2A shows a view of an adapter with the impactor which has 4 different degrees of rotation around the impaction axis;
- [0031] FIG. 2B shows an impactor, adapter, and surgical implement as three separate pieces;
- [0032] FIG. 2C shows the impactor, adapter, and surgical implement connected;
- [0033] FIG. 3 shows a cross sectional view of the impactor;
- [0034] FIG. 4 shows the masses of the impacting tool for calculating mass ratios;
- [0035] FIG. 5 shows the measurement of TIR for an adapter connected to the output of the tool;
- [0036] FIG. 6A shows the adapter, with a reciprocal sleeve, on insertion of the adapter on the tool;
- [0037] FIG. 6B shows the adapter, with the reciprocal sleeve, on removal of the adapter from the tool;
- [0038] FIG. 7 shows an orthopedic implement used to shape a bone by providing cutting teeth in at least one direction; and
- [0039] FIG. 8 shows an adapter including a feature that communicates with the impactor or surgical implement.

DETAILED DESCRIPTION OF ILLUSTRATIVE EMBODIMENTS

[0040] The description set forth below in connection with the appended drawings is intended to be a description of various, illustrative embodiments of the disclosed subject matter.

Specific features and functionalities are described in connection with each illustrative embodiment; however, it will be apparent to those skilled in the art that the disclosed embodiments may be practiced without each of those specific features and functionalities.

[0041] Reference throughout the specification to “one embodiment” or “an embodiment” means that a particular feature, structure, or characteristic described in connection with an embodiment is included in at least one embodiment of the subject matter disclosed. Thus, the appearance of the phrases “in one embodiment” or “in an embodiment” in various places throughout the specification is not necessarily referring to the same embodiment. Further, the particular features, structures or characteristics may be combined in any suitable manner in one or more embodiments. Further, it is intended that embodiments of the disclosed subject matter cover modifications and variations thereof.

[0042] It must be noted that, as used in the specification and the appended claims, the singular forms “a,” “an,” and “the” include plural referents unless the context expressly dictates otherwise. That is, unless expressly specified otherwise, as used herein the words “a,” “an,” “the,” and the like carry the meaning of “one or more.” Additionally, it is to be understood that terms such as “left,” “right,” “top,” “bottom,” “front,” “rear,” “side,” “height,” “length,” “width,” “upper,” “lower,” “interior,” “exterior,” “inner,” “outer,” and the like that may be used herein merely describe points of reference and do not necessarily limit embodiments of the present disclosure to any particular orientation or configuration. Furthermore, terms such as “first,” “second,” “third,” etc., merely identify one of a number of portions, components, steps, operations, functions, and/or points of reference as disclosed herein, and likewise do not necessarily limit embodiments of the present disclosure to any particular configuration or orientation.

[0043] Furthermore, the terms “approximately,” “about,” “proximate,” “minor variation,” and similar terms generally refer to ranges that include the identified value within a margin of 20%, 10% or preferably 5% in certain embodiments, and any values therebetween.

[0044] All of the functionalities described in connection with one embodiment are intended to be applicable to the additional embodiments described below except where expressly stated or where the feature or function is incompatible with the additional embodiments. For example, where a given feature or function is expressly described in connection with one embodiment but not expressly mentioned in connection with an alternative embodiment, it should be understood that the inventor intends that that feature or function may be deployed, utilized or implemented in connection with the alternative embodiment unless the feature or function is incompatible with the alternative embodiment.

[0045] Describing now an exemplary tool with which the improved adapter may communicate, a motor-driven orthopedic impacting tool is provided with controlled percussive impacts. The motor may be electric, such as a brushless, autoclavable motor such as those generally available from Maxon Motor® and/or Portescap®. The motor may be battery-operated. The energy supply to the orthopedic impacting tool may provide wireless portability and communication for the orthopedic impacting tool. The tool may include the capabilities to perform single and multiple impacts, as well as impacting of variable and varying directions, forces, and frequencies. In some embodiments, the impact energy is adjustable. In certain embodiments, the impact is transferred to a surgical implement such as a broach, chisel, or other end effector connected to the tool.

[0046] In some embodiments, the tool includes a housing. The housing may securely cover and hold at least one component of the tool and may be formed of a material suitable for surgical applications, such as aluminum or Polyphenylsulfone (PPSF or PPSU), also known as Radel®. In some embodiments, the housing contains a motor assembly, at least one

reducing gear, a spring element, a striker or launched mass, a control circuit or module, an anvil, a first or forward striking surface for forward impact, and a different, second or rearward striking surface for rearward impact. The motor assembly may include a linear motion converter to convert a rotary motor drive. The spring element may be a mechanical, elastomeric, or gas spring.

[0047] The tool further may include a handle portion with an optional hand grip for comfortable and secure holding of the tool, or a suitable mount interface for integrating the tool into a robotic assembly while in use, and an adapter, a battery, a positional sensor, a directional sensor, and a torsional sensor. The tool may further deliver focused illumination by way of a semiconductor light source, such as an LED or traditional incandescent light source, to provide light in the surgical work area in which a surgeon employs the tool. The anvil may be coupled to a surgical implement broach, chisel or other end effector known in the art through the use of an interfacing adapter, which adapter may have a quick connect mechanism to facilitate rapid change of different broaching sizes. The tool may further include an axially locking, but rotationally variable, feature to allow the adapter to be positioned in different spatial fashions as to gain tissue clearance for tool features such as the handle.

[0048] In some embodiments, an axis of the launched or thrown mass is aligned axially, along the direction of movement, to within 20 degrees of the axis of the adapter, and more preferably, to within 10 degrees of the axis of the adapter. Such axial alignment is significant in terms of maximizing the energy transferred to the surgical implement, as well as minimizing the generation of off-axis forces, which can contribute to adverse surgical outcomes, such as fractures. The inventor discovered that these benefits of axial alignment were, in part, a result of bone being an anisotropic material, rendering it stronger with respect to compression or tension forces than it is with respect to shear forces.

[0049] It has been determined by the inventor that the mass ratios and materials used for the launched or thrown mass, the anvil, and the adapter are significant in terms of how effectively the kinetic energy of the thrown mass is conveyed to the surgical implement. For purposes of certain embodiments, the ratio of the delivered energy to the surgical implement as a function of the kinetic energy in the thrown mass or striker is referred to as the transfer function. The transfer function is used as a measure of performance, in terms of how efficiently the tool is performing broaching, impacting, or extraction surgical procedures. For example, in one design in which the thrown mass, anvil, and adapter were all made of hardened stainless steel, the ratio of the energy conveyed to the surgical implement to the kinetic energy of the thrown mass, or the transfer function, was found to be less than 50%. By increasing the mass ratio of the thrown mass to the impacted mass (the sum of the mass of the anvil, the adapter, and the surgical implement), the efficiency of the adapter and the system, in particular, the transfer function of the adapter and the system, was increased to greater than 60%, and in many cases, close to 75%. FIG. 4 shows an embodiment of the tool and illustrates the aforementioned masses, including impacted mass 400 and thrown mass 402.

[0050] The tool, in further embodiments, includes a compliance element inserted between the striker and the adapter. Preferably, the compliance element is a resilient material that recovers well from impact and imparts minimal damping on the total energy. As an example, a urethane component could be inserted at the interface where the striker impacts the anvil. In another example, the compliance element may be inserted in such a fashion that it only reduces the impact force in the forward direction and does not affect the desire for a sharp impact force in the rearward direction. This type of compliance element can limit the peak force during impact to preclude such peaks from causing fractures in the patient's bone, yet maintain the high peak force necessary to be able to retract stuck broaches or other surgical implements.

[0051] In some embodiments, the impactor is coupled to a robot, for example, thus potentially eliminating the need for a portable power source (battery) and/or hand grip on the tool.

[0052] In some embodiments, the coupling of the adapter to the tool includes a linkage arrangement or other adjustment mechanisms known in the art such that the position of the surgical implement (broach, chisel or other end effector) can be modified without requiring the surgeon to rotate the tool.

[0053] FIG. 1 shows a perspective view of an example of an orthopedic impacting tool with which an improved adapter may communicate. A motor 8 of a mechanical spring assembly system, in combination with a linear motion converter, which includes a barrel or cylindrical cam 12 and a cam follower 13, actuates a first spring piston 19a and/or a launched mass or striker 15, in order to ultimately generate a forward impact force is provided (also provided is a second spring piston 19b to engage a second spring 2b being compressed against a second pusher plate 26b to generate a rearward impact force). It is to be noted that the piston generally refers to a thrusting or push off element and can have any of a number of shapes. The spring assembly system further includes, in some embodiments, an anvil 5.

[0054] The barrel cam 12 can include a cylindrical portion 120 mounted longitudinally on a shaft 122 extending between the motor 8 and a bearing support 124, and a worm 126 protruding radially from the cylindrical portion 120 and helicoidally along a length of the cylindrical portion 120 from a first worm end 126a to a second worm end 126b.

[0055] The bearing support 124 can include a housing 125 supported by the second pusher plate 26b and a bearing nested in the housing 125 to support the shaft 122.

[0056] The worm 126 can include a backward surface 126bs, e.g. the surface facing a first pusher plate 26a, and a forward surface 126fs of the worm 126, e.g. the surface facing the second pusher plate 26b, that contacts the cam follower 13 and forces the cam follower 13 to

follow a rectilinear movement between the first worm end 126a and the second worm end 126b as the worm 126 rotates.

[0057] The cam follower 13 can be displaced along the worm 126 in the forward direction, e.g. towards the second pusher plate 26b, by having the cam follower 13 contacting the forward surface 126fs of the worm 126 and having the worm 126 rotating in a first direction 42a.

[0058] The cam follower 13 can be displaced along the worm 126 in the backward direction, e.g. towards the first pusher plate 26a, by having the cam follower 13 contacting a backward surface 126bs of the worm 126, e.g. the surface facing the pusher plate 26a, and having the worm 126 rotating in a second direction opposite to the first direction 42a.

[0059] Bumpers 14a and 14b function as stoppers to prevent end faces of the piston 19a and 19b from impacting the striker 15.

[0060] The barrel cam 12 can enhance efficiency of the orthopedic impacting tool by allowing the motor 8 to rotate with larger angles compared to a conventional linear motion converter that may rely on conventional vertical cams that hit the cam follower 13 through small repetitive strokes. That is, the barrel cam 12 allows the use of more radians of rotation for the motor to get the energy and thus, reduces the current drain on the battery significantly. Accordingly, a single primary battery could be used in certain embodiments by utilizing the advantages provided by the barrel cam 12 in the reduction of the current drain.

[0061] In addition, the barrel cam 12 can in certain cases allow for the elimination of an intermediate gear assembly, as the barrel cam 12 can be directly mounted onto the shaft 122 and thus enhance efficiency whilst reducing the cost of the orthopedic tool.

[0062] The tool, in some embodiments, facilitates controlled continuous impacting, which impacting is dependent on a position of the trigger switch 30 operatively coupled to the power source or motor, for example. For such continuous impacting, after the trigger switch

is activated, and depending on the position of the trigger switch 30, the tool may go through complete cycles at a rate proportional to the position of the trigger switch, for example. Thus, in either the single impact or continuous impacting operational modes, the creation or shaping of the surgical area may be easily controlled by the surgeon.

[0063] In some embodiments, as the barrel cam 12 assembly completes its course, e.g. the cam follower 13 is displaced along either the backward surface 126bs or the forward surface 126fs between the first worm end 126a and the second worm end 126b, it preferably activates the sensor 28 coupled operatively to a controller 21. The sensor 28 assists in the regulation of the preferred cyclic operation of the barrel cam 12. For example, the sensor 28 may signal the motor 8 to stop such that the barrel cam 12 is at or near a point of minimal potential energy storage. Thus, in one complete cycle, a forward or a rearward impacting force may be applied on the broach, chisel, or other end effector, or on the implant or prosthesis. In a further embodiment, it may be advantageous to insert a delay or count the number of impacts for any give procedure before starting the next cycle, making it possible to accurately control the speed of impacting, and, in turn, allowing the surgeon to accurately control the rate of energy delivery in any given operation. In a still further embodiment, it may be advantageous to stop the barrel cam 12 near a point of maximum potential energy storage to reduce a latency in the surgeons' hands. Latency, as defined, is the time between when the surgeon (or user) activates the orthopedic impacting tool and the tool actually delivers an impact. It has been determined by the inventor that latencies of around 100 milliseconds or less appear essentially as an instantaneous response. By stopping the barrel cam 12 at a point where at least part of the potential energy has been stored, the tool has the effect of near instantaneous release of the potential energy upon actuation of a tool trigger 30.

[0064] Referring now generally to FIGs. 2A-8, an orthopedic impactor is shown with various configurations of adapters for use therewith.

[0065] FIG. 2A illustrates a surgical impactor 200 and adapter 202 in which the adapter 202 can be inserted into the impactor 200 in any of 4 different rotations around the impacting axis. Of course, while insertion via 4 different rotations are shown via the illustrated square interface in FIG. 2A, additional rotational positions would be possible. For example, an adapter with a hexagonal interface could have 6 different rotational configurations, and an adapter with an octagonal interface could have 8 different rotational configurations. The different insertion angles allow for multiple positioning of the surgical implement while maintaining the ability of the surgeon to hold the tool in a more ergonomic orientation.

[0066] In FIGs. 2B and 2C, an impactor 200, adapter 202 and surgical implement 204 (e.g., a broach) are shown in both an unconnected state and in a connected state.

[0067] FIG. 3 illustrates an embodiment in which the multiple surfaces of the adapter, such as a surface for forward impacts 300 and a surface for rearward impacts 302, allow for both proximal and distal impacts on the adapter and consequently to the surgical implement. The ability to produce impacts proximally and distally is especially useful when implements become lodged in a cavity. By applying a direct reverse blow to the adapter, the lodged implement can easily be dislodged from the cavity. It was discovered by the inventor that the surface areas should be designed to withstand impact forces ranging from 1 kilonewton to 50 kilonewtons, and more particularly about 15 kilonewtons, for general durability over time as a surgical impactor.

[0068] FIG. 5 illustrates a position on the adapter where the TIR of the adapter can be measured. As shown in the figure, the TIR of the adapter should be measured at the tip 500 of the adapter, and in some embodiments, the adapter should be designed such that the TIR is less than 5 mm and more preferably less than 2 mm. With a small TIR, the precision of the orthopedic impactor is increased. In use, this precision translates into minimized distortion of the cavity, less energy loss laterally, improved fitting of implants, and improved surgical

outcomes. By comparison, other known surgical implements have TIRs on the order of 20 mm. A TIR of 2 mm or less is a significant improvement and produces cavities with significantly more precise forms and shapes.

[0069] FIGs. 6A and 6B illustrate one embodiment of the insertion and removal procedures of the adapter connection to the impactor via a reciprocal sleeve.

[0070] In one embodiment, the reciprocal sleeve can include a release collar 606, snap ring 604, and retaining clips 602. As shown in FIG. 6A, the adapter 202 is inserted via a single insertion motion 600, towards the impactor, to secure the connection to the impactor 200. During that motion, retaining clips 602 within a release collar 606 are forced apart as the adapter 202 moves inward. A snap ring 604 locks, or otherwise seats and holds, in place the retaining clips 602 on the adapter 202. In one example, the snap ring 604 can be an o-ring but may also be implemented as a garter spring or elastomer ring.

[0071] As shown in FIG. 6B, the adapter 202 can be disconnected from the impactor by depressing a release collar 606. The release collar 606 includes cam surfaces 608 configured to separate the retaining clips 602 as the release collar 606 is moved. When the retaining clips 602 are separated enough to clear the adapter 202, the adapter 202 may be moved outward away from the impactor 200. In an alternative example, the reciprocal sleeve may include a pinion and rack in place of cam surfaces 608 to separate the retaining clips 602 as the adapter 202 is disconnected from the impactor.

[0072] As shown in FIG. 7, a surgical implement for use with the adapter and an electrically driven orthopedic impactor has cutting teeth 700 for shaping a bone 702 to accept an implant. In one example, the cutting teeth 700 can be arranged on a surface of the impactor such that the teeth 700 cut linearly with an axis of the impactor. In a further embodiment, the teeth may be configured in such a fashion as to improve the fitment of a press fit implant such as a knee.

In still a further embodiment, the surgical implement for use with the adapter may include features which increase the surface area available for bonding with adhesive implants.

[0073] FIG. 8 illustrates an example of a sensor 800 included on the adapter 202, which communicates information to the impactor and allows the surgeon to control the impactor more accurately. The information may be used to adjust the stroke, power, or frequency of impacts, for example. For instance, if the adapter is being used in seating a head ball, where continuous impacting is not desired, the adapter sensor may be configured to communicate back to the impactor a requirement for single-shot actuation rather than repeated impacts. In this situation, surgical outcomes will be improved, as the surgeon will be less likely to cause implant subsidence during head ball impaction. The adapter may detect the surgical implement and its type or configuration information, such as in the head ball placement tool example above, by communicating with the surgical implement using the same sensor or a second sensor. In some embodiments, the surgical implement is integrally formed with, and thus not detachable from, the adapter. In those embodiments, the adapter stores information relating to the surgical implement and readily communicates the information to the impactor.

[0074] As another example, communication and control of frequency information allows the tool to precisely and consistently control the frequency of the impacting movement. By regulating the frequency of the striker, the tool may impart a greater total time-weighted percussive impact, while maintaining the same impact magnitude. This allows the surgeon better control over the cutting speed of the surgical implement. For example, the surgeon may choose cutting at a faster rate (higher frequency impacting) during the bulk of the surgical implement movement and then slow the cutting rate as the surgical implement approaches a desired depth. In fact, during testing of the tool, it was discovered that a higher frequency impacting rate, such as 3 impacts per second, preferably up to 10 impacts per second, coupled with a substantially constant energy per impact, delivering between 2 to 6 joules per second,

preferably up to 40 joules per second, allowed the surgeon to better position certain surgical implements. This was seen, for example, in the seating of an acetabular cup, where an impact frequency of at least 3 impacts per second, at an energy of between 2 and 6 joules per second, resulted in far better control of the position of the acetabular cup over the prior art manual hammering technique. In a further unexpected benefit of the rapid impacting capabilities of the electric driven orthopedic impactor, the inventor discovered that the energy to perform an operation could be reduced as the movement of the surgical implement was more fluid and continuous (i.e., less of a start and stop function similar to mallet blows). This benefit of rapid impacting (e.g., at a rate greater than 3 times per second) finds its basis in engineering differences between static and dynamic friction. Dynamic friction is almost always less than static friction, and as such, a more continuous movement of a broach, implant, or other surgical implement allows for lower overall forces during the operation. In addition, it has been the inventor's experience in the operating room that the near continuous movement of the surgical implement not only lowers the total energy required but also results in a better surgical outcome. In a specific case of a reamed acetabulum, a reamer may leave valleys and peaks. By using a more continuous or higher frequency impacting described herein, the valleys and peaks are reduced and in effect ironed out. This has been clearly seen in numerous cadaver labs. Specifically in the placement of the cup into the acetabulum, better fixation results from the more intimate contact between the surfaces.

[0075] Information communicated between the adapter, the impactor, and the surgical implement may be in the form of settings or other identification information, which are then referenced in tables or databases to determine the configuration settings as discussed in the examples above. Communication between the adapter, the surgical impactor, and the surgical implement can be performed in a variety of ways, including mechanically, magnetically,

electrically, or wirelessly (such as through radio-frequency identification (RFID) technologies and the like).

[0076] While certain embodiments have been described, these embodiments have been presented by way of example only, and are not intended to limit the scope of the present disclosures. Indeed, the novel methods, apparatuses and systems described herein can be embodied in a variety of other forms; furthermore, various omissions, substitutions and changes in the form of the methods, apparatuses and systems described herein can be made without departing from the spirit of the present disclosures. The accompanying claims and their equivalents are intended to cover such forms or modifications as would fall within the scope and spirit of the present disclosures.

CLAIMS

What is claimed is:

1. An adapter configured to interface between an electrically driven orthopedic impactor and a surgical implement, comprising:

a first surface to transmit a forward impact energy; and

a second surface to transmit a reverse impact energy, wherein

the adapter is configured to connect to the surgical implement and to the orthopedic impactor without the use of external tools.

2. The adapter of claim 1, wherein a total indicator reading (TIR) between a tip of the adapter and the orthopedic impactor is less than 5 mm.

3. The adapter of claim 1, wherein a weight of the adapter is less than a weight of a striker in the orthopedic impactor.

4. The adapter of claim 3, wherein the weight of the adapter is less than 40% of the weight of the orthopedic impactor.

5. The adapter of claim 1, wherein an adapter transfer function exceeds 60%.

6. An adapter configured to interface between an electrically driven orthopedic impactor and a surgical implement, comprising:

a reciprocal sleeve, wherein

the adapter is configured to connect to the orthopedic impactor via a pushing motion,

and

the adapter is configured to disconnect from the orthopedic impactor via the reciprocal sleeve.

7. The adapter of claim 6, wherein the adapter is configured for insertion into the orthopedic impactor in at least 4 orientations along an axis of the orthopedic impactor.

8. The adapter of claim 6, further comprising a communicator that communicates to the orthopedic impactor to change one of a frequency, energy, or throw of the orthopedic impactor.

9. The adapter of claim 6, wherein the adapter generates an audible or visual cue that indicates that the adapter is connected to the electrically driven orthopedic impactor.

10. The adapter of claim 6, further comprising a dampener that reduces the impact energy from the orthopedic impactor in a forward direction by at least 20%.

11. The adapter of claim 6, wherein the surgical implement includes teeth adapted for cutting bone, the teeth having a tooth-to-tooth spacing distance less than a throw distance of the impactor.

12. The adapter of claim 11, wherein the teeth include bidirectional cutting teeth configured to cut bone on both a forward impact and rearward impact of the impactor.

13. The adapter of claim 6, wherein the surgical implement is adapted for increasing a surface area available for an adhesive bond of a surgical implant.

14. The adapter of claim 6, wherein the surgical implement includes at least one cutting surface or tooth for cutting linearly with an axis of the impactor.

15. An adapter for interfacing with an impactor, comprising:

a sensor configured to communicate a spatial orientation of the adapter with respect to at least one reference point, the reference point not being located on the adapter or the impactor.

16. An adapter configured to interface between an electrically driven orthopedic impactor and a surgical implement, comprising:

a communication device configured to transmit frequency information or impact energy information to the electrically driven orthopedic impactor based on a type of the surgical implement attached to the adapter.

17. The adapter of claim 16, wherein the adapter is configured to receive information indicating the type of the surgical implement from the surgical implement via the communication device.

18. The adapter of claim 17, wherein the communication device operates wirelessly.

19. The adapter of claim 16, wherein the surgical implement is integrated with, and not detachable from, the adapter.

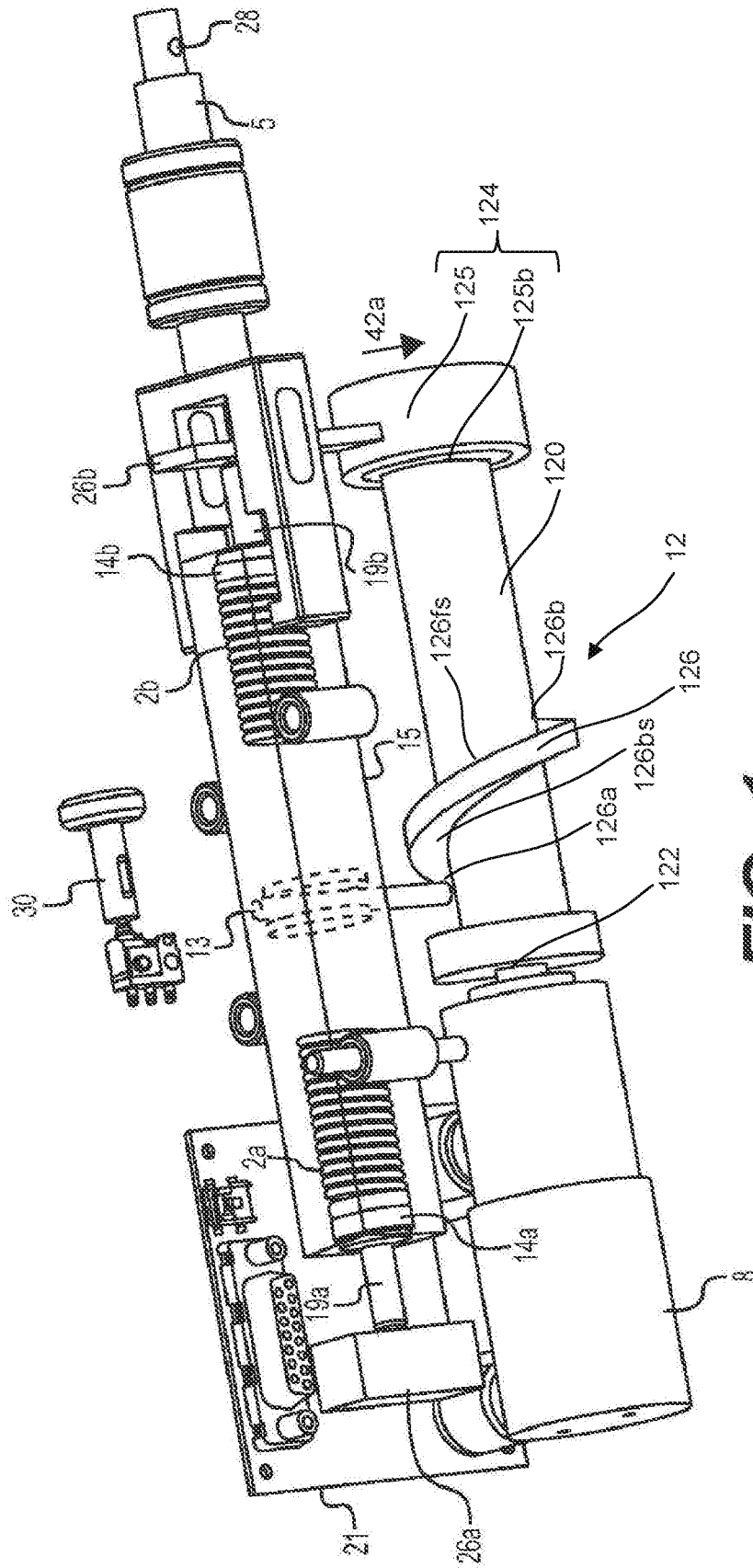

FIG. 1

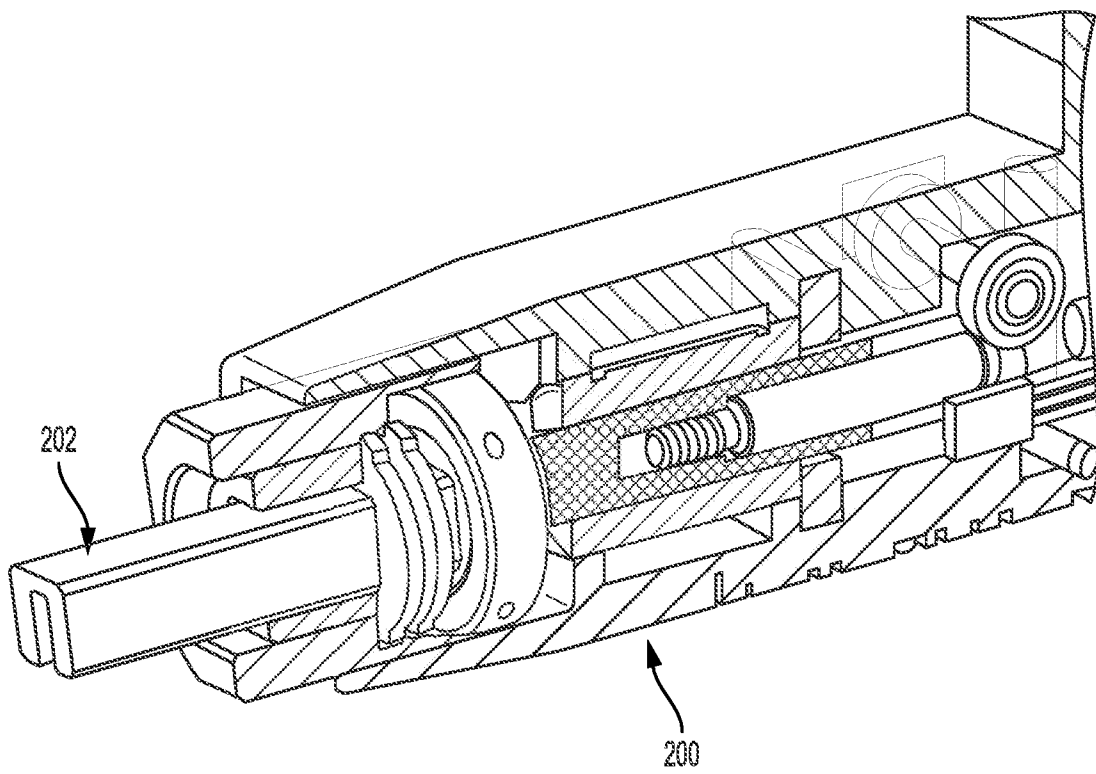

FIG. 2A

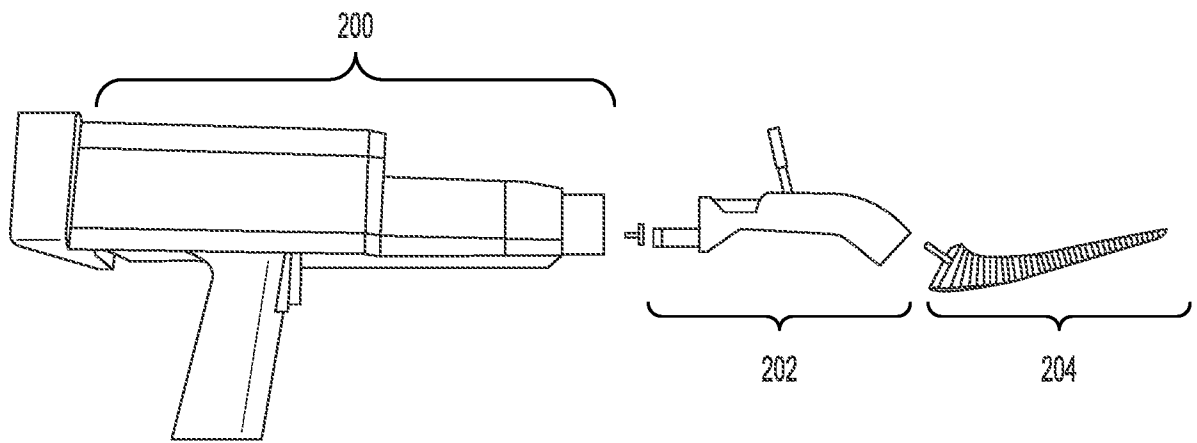

FIG. 2B

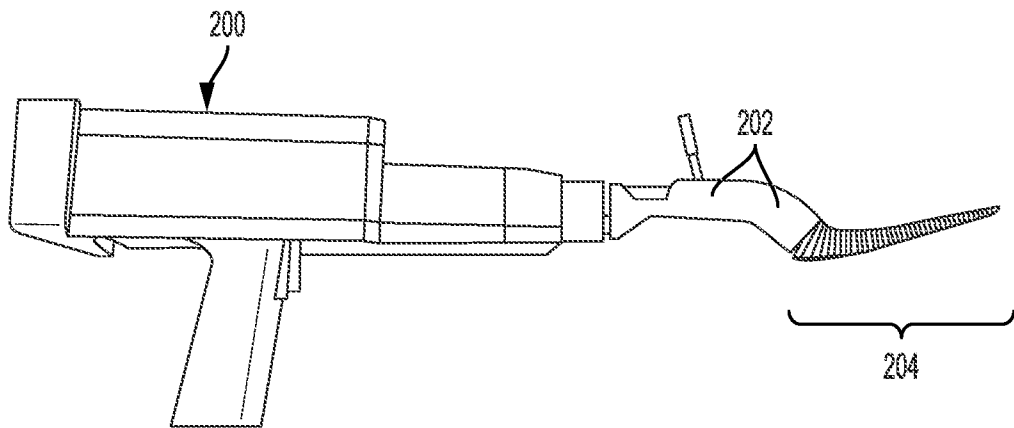

FIG. 2C

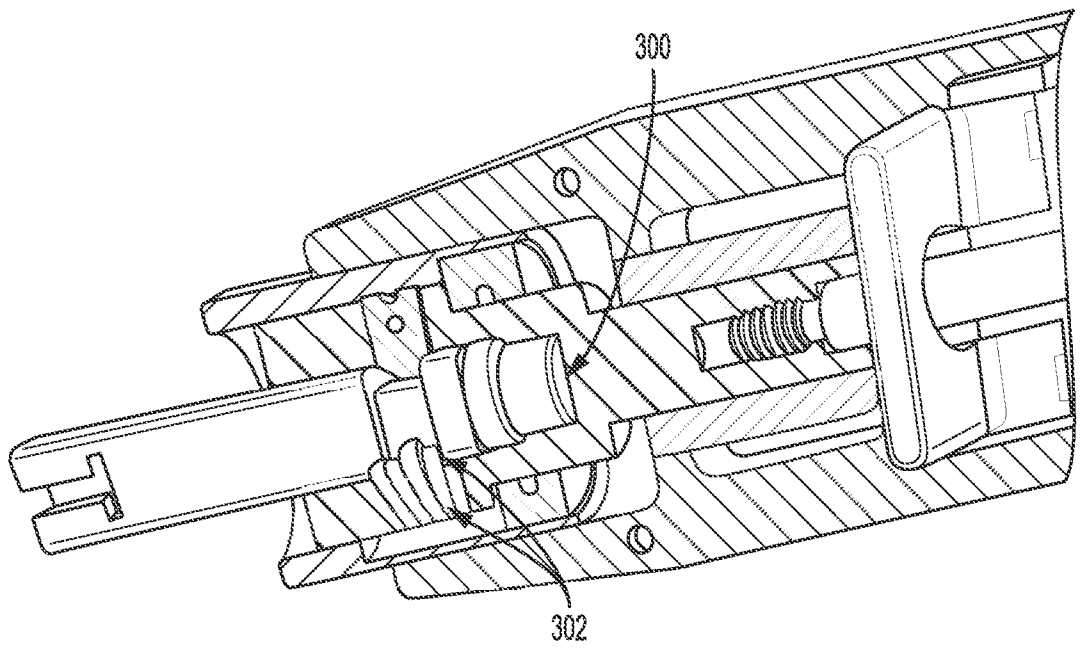

FIG. 3

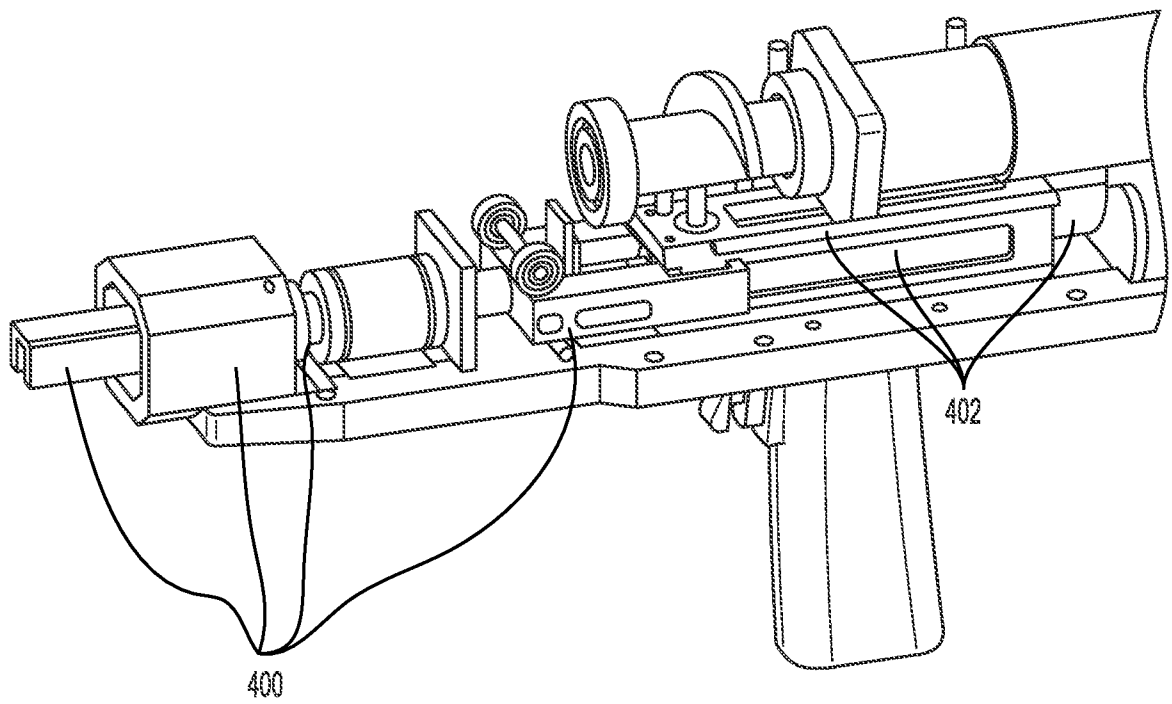

FIG. 4

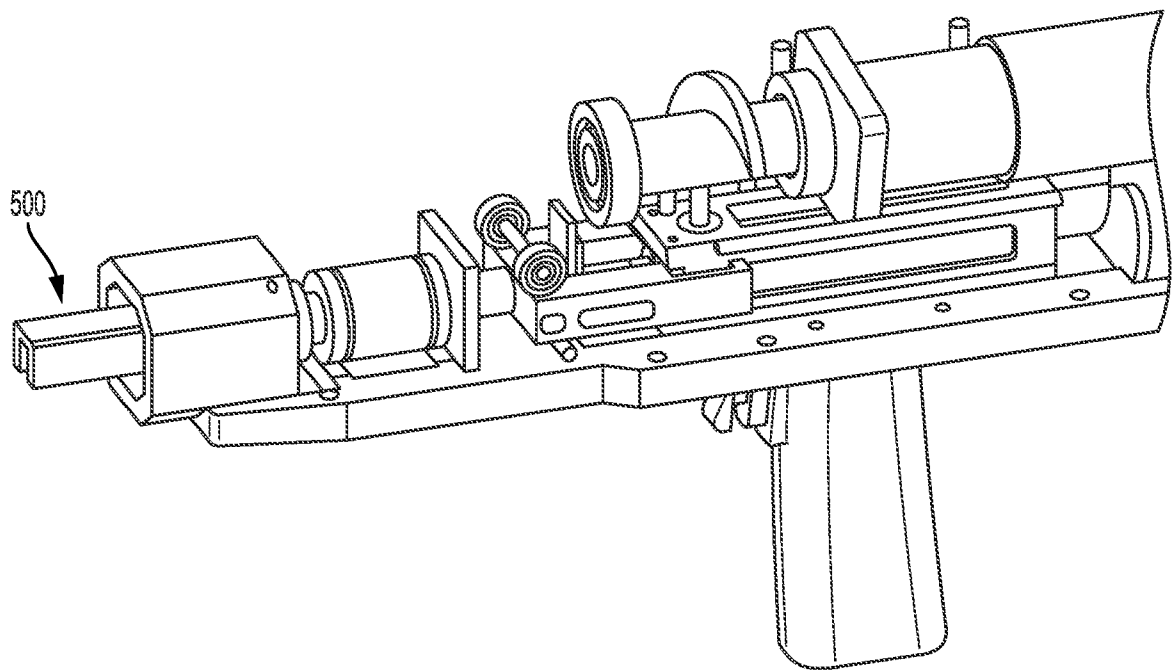

FIG. 5

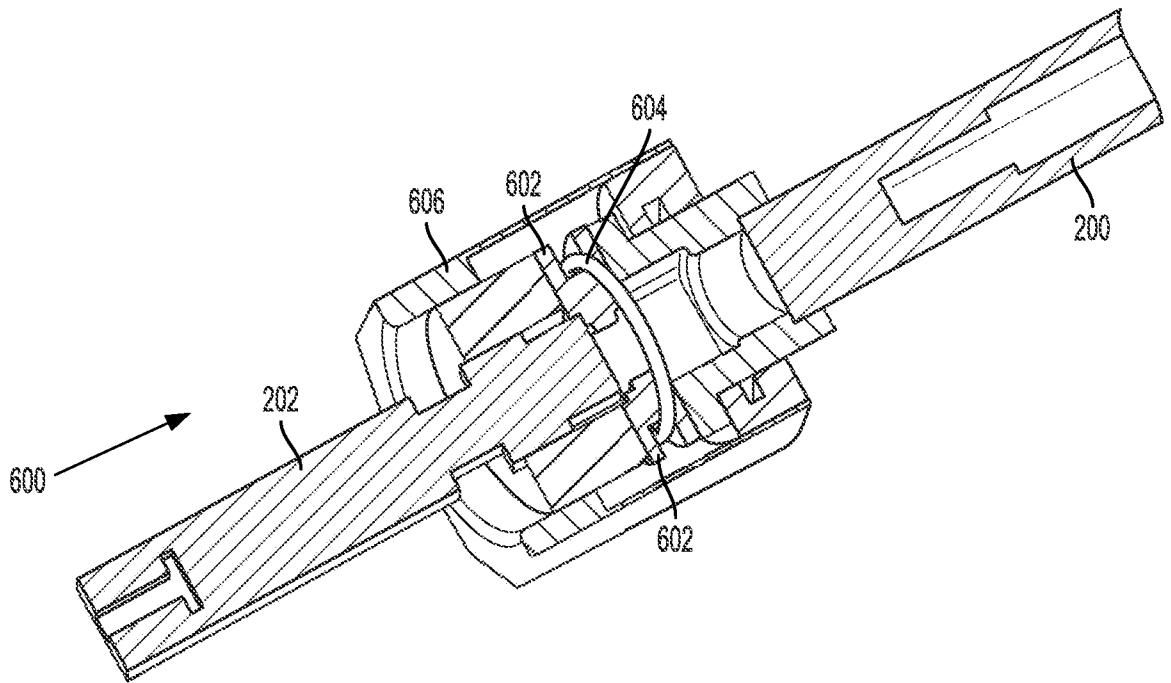

FIG. 6A

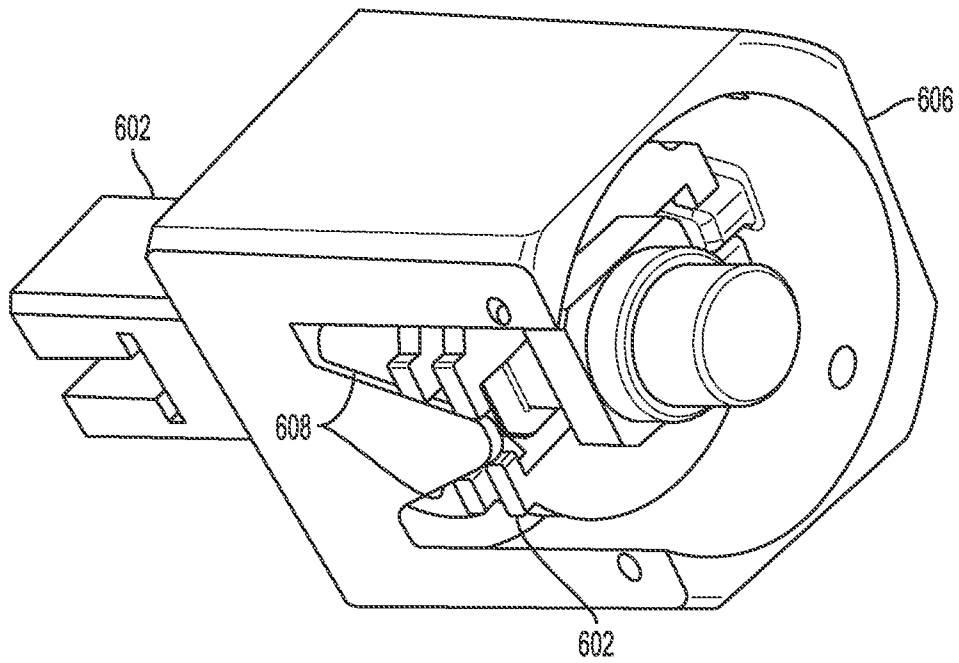

FIG. 6B

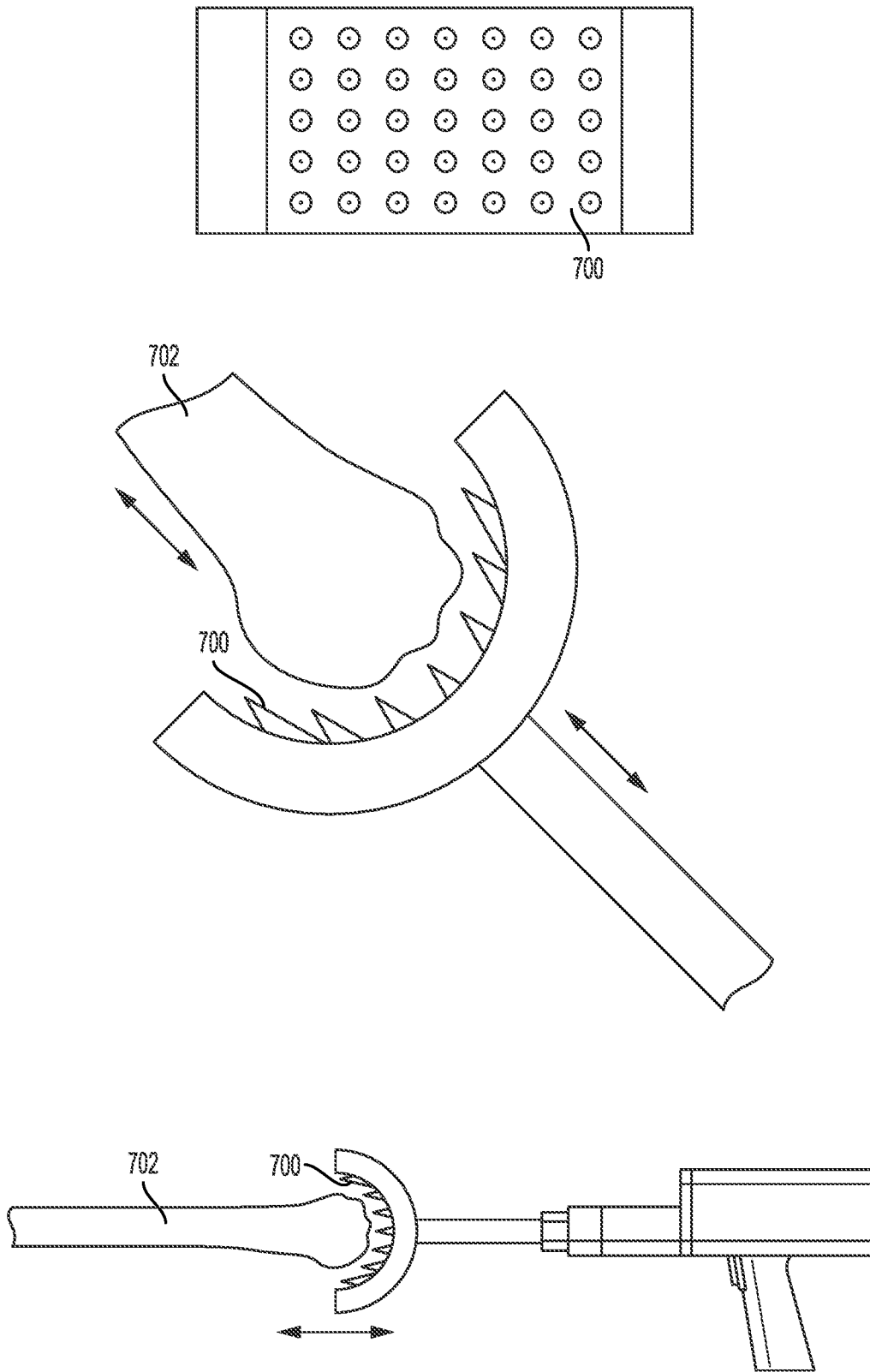

FIG. 7

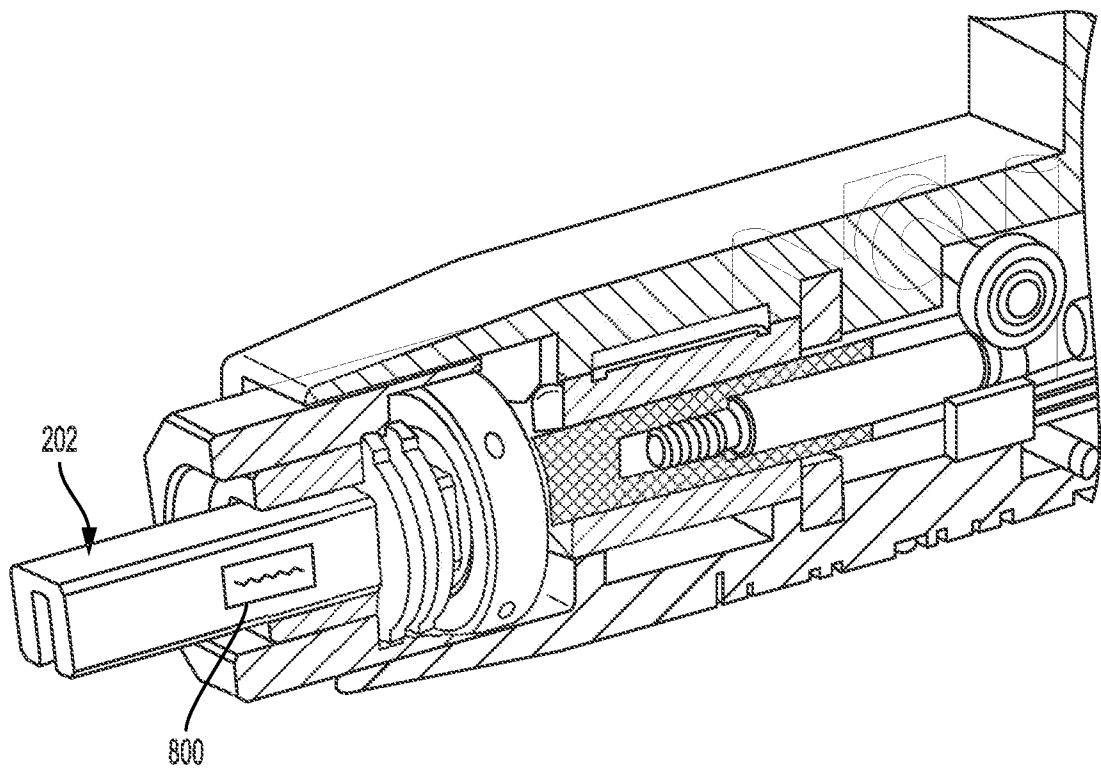

FIG. 8

INTERNATIONAL SEARCH REPORT

International application No.

PCT/US 18/24934

A. CLASSIFICATION OF SUBJECT MATTER

IPC(8) - A61B 17/92 (2018.01)

CPC - A61B 2017/922

According to International Patent Classification (IPC) or to both national classification and IPC

B. FIELDS SEARCHED

Minimum documentation searched (classification system followed by classification symbols)

See Search History Document

Documentation searched other than minimum documentation to the extent that such documents are included in the fields searched

See Search History Document

Electronic data base consulted during the international search (name of data base and, where practicable, search terms used)

See Search History Document

C. DOCUMENTS CONSIDERED TO BE RELEVANT

Category*	Citation of document, with indication, where appropriate, of the relevant passages	Relevant to claim No.
X	US 2013/0161050 A1 (PEDICINI); 27 June 2013 (27.06.2013); entire document, especially Figs. 6-9, Abstract, paras. [0018], [0040], [0042], [0048]-[0049], [0059].	1
--		---
Y		2-5
Y	US 5,485,887 A (MANDANIS); 23 January 1996 (23.01.1996); entire document, especially Figs. 1-2, col. 2, ln 48- col. 4, ln 2.	2
Y	US 5,352,230 A (HOOD); 4 October 1994 (04.10.1994); entire document, especially Fig. 6, Abstract, col. 9, ln 56- col. 10, ln 1; col. 15, ln 59-65; col. 18, ln 10-20, col. 18, ln 46-52.	3-5
A	US 2017/0020536 A1 (AC (Macao Commercial Offshore) Limited); 26 January 2017 (26.01.2017); entire document.	1-5
A	US 2012/0232556 A1 (MANI et al.); 13 September 2012 (13.09.2012); entire document.	1-5
A	US 2015/0182233 A1 (TENJIN LLC); 2 July 2015 (02.07.2015); entire document.	1-5
A	US 2015/0005777 A1 (FERRO et al.); 1 January 2015 (01.01.2015); entire document.	1-5

 Further documents are listed in the continuation of Box C. See patent family annex.

* Special categories of cited documents:

"A" document defining the general state of the art which is not considered to be of particular relevance

"E" earlier application or patent but published on or after the international filing date

"L" document which may throw doubts on priority claim(s) or which is cited to establish the publication date of another citation or other special reason (as specified)

"O" document referring to an oral disclosure, use, exhibition or other means

"P" document published prior to the international filing date but later than the priority date claimed

"T" later document published after the international filing date or priority date and not in conflict with the application but cited to understand the principle or theory underlying the invention

"X" document of particular relevance; the claimed invention cannot be considered novel or cannot be considered to involve an inventive step when the document is taken alone

"Y" document of particular relevance; the claimed invention cannot be considered to involve an inventive step when the document is combined with one or more other such documents, such combination being obvious to a person skilled in the art

"&" document member of the same patent family

Date of the actual completion of the international search

25 July 2018

Date of mailing of the international search report

03 AUG 2018

Name and mailing address of the ISA/US

Mail Stop PCT, Attn: ISA/US, Commissioner for Patents
P.O. Box 1450, Alexandria, Virginia 22313-1450
Facsimile No. 571-273-8300

Authorized officer:

Lee W. Young

PCT Helpdesk: 571-272-4300
PCT OSP: 571-272-7774

INTERNATIONAL SEARCH REPORT

International application No.

PCT/US 18/24934

Box No. II Observations where certain claims were found unsearchable (Continuation of item 2 of first sheet)

This international search report has not been established in respect of certain claims under Article 17(2)(a) for the following reasons:

1. Claims Nos.:
because they relate to subject matter not required to be searched by this Authority, namely:

2. Claims Nos.:
because they relate to parts of the international application that do not comply with the prescribed requirements to such an extent that no meaningful international search can be carried out, specifically:

3. Claims Nos.:
because they are dependent claims and are not drafted in accordance with the second and third sentences of Rule 6.4(a).

Box No. III Observations where unity of invention is lacking (Continuation of item 3 of first sheet)

This International Searching Authority found multiple inventions in this international application, as follows:
This application contains the following inventions or groups of inventions which are not so linked as to form a single general inventive concept under PCT Rule 13.1. In order for all inventions to be examined, the appropriate additional examination fees must be paid.

Group I: Claims 1-5 directed to an adapter comprising a first surface and a second surface.

Group II: Claims 6-14 directed to an adapter comprising a reciprocal sleeve.

Group III: Claim 15 directed to an adapter comprising a sensor.

Group IV: Claims 16-19 directed to an adapter comprising a communication device.

-*-Continued in extra sheet*-*

1. As all required additional search fees were timely paid by the applicant, this international search report covers all searchable claims.
2. As all searchable claims could be searched without effort justifying additional fees, this Authority did not invite payment of additional fees.
3. As only some of the required additional search fees were timely paid by the applicant, this international search report covers only those claims for which fees were paid, specifically claims Nos.:

4. No required additional search fees were timely paid by the applicant. Consequently, this international search report is restricted to the invention first mentioned in the claims; it is covered by claims Nos. 1-5

Remark on Protest

- The additional search fees were accompanied by the applicant's protest and, where applicable, the payment of a protest fee.
- The additional search fees were accompanied by the applicant's protest but the applicable protest fee was not paid within the time limit specified in the invitation.
- No protest accompanied the payment of additional search fees.

-*Box No. III- Observations where unity of invention is lacking-*

The inventions listed as Groups I-IV do not relate to a single general inventive concept under PCT Rule 13.1 because, under PCT Rule 13.2, they lack the same or corresponding special technical features for the following reasons:

SPECIAL TECHNICAL FEATURES

The invention of Group I includes the special technical features of an adapter comprising a first surface to transmit a forward impact energy; and a second surface to transmit a reverse impact energy, not required in Groups II-IV.

The invention of Group II includes the special technical features of an adapter comprising a reciprocal sleeve, not required in Groups I, and III-IV.

The invention of Group III includes the special technical features of an adapter comprising a sensor configured to communicate a spatial orientation of the adapter with respect to at least one reference point, the reference point not being located on the adapter or the impactor, not required in Groups I-II, and IV.

The invention of Group IV includes the special technical features of an adapter comprising a communication device configured to transmit frequency information or impact energy information to the electrically driven orthopedic impactor based on a type of the surgical implement attached to the adapter, not required in Groups I-III.

COMMON TECHNICAL FEATURES

The inventions of Groups I-IV share the technical features of an adapter for interfacing with an impactor. The common technical features are known in prior art as shown in US 2014/0318823 A1 to Pedicini (hereinafter 'Pedicini'), which teaches an adapter for interfacing with an impactor (adapter 1 interfacing with anvil 14, Fig. 5, para. [0036]).

The inventions of Groups I-II and IV share the technical features of an adapter configured to interface between an electrically driven orthopedic impactor and a surgical implement. The common technical features are known in Pedicini, which teaches an adapter configured to interface between an electrically driven orthopedic impactor and a surgical implement (anvil 14 communicates a force to the adapter 1 and the broach, chisel or other orthopedic instrument, Fig. 5, para. [0036]).

As the common features were known in the art at the time of the invention, they cannot be considered special technical features that would otherwise unify the groups.

Therefore, Groups I-IV lack unity under PCT Rule 13 because they do not share a same or corresponding special technical feature.