

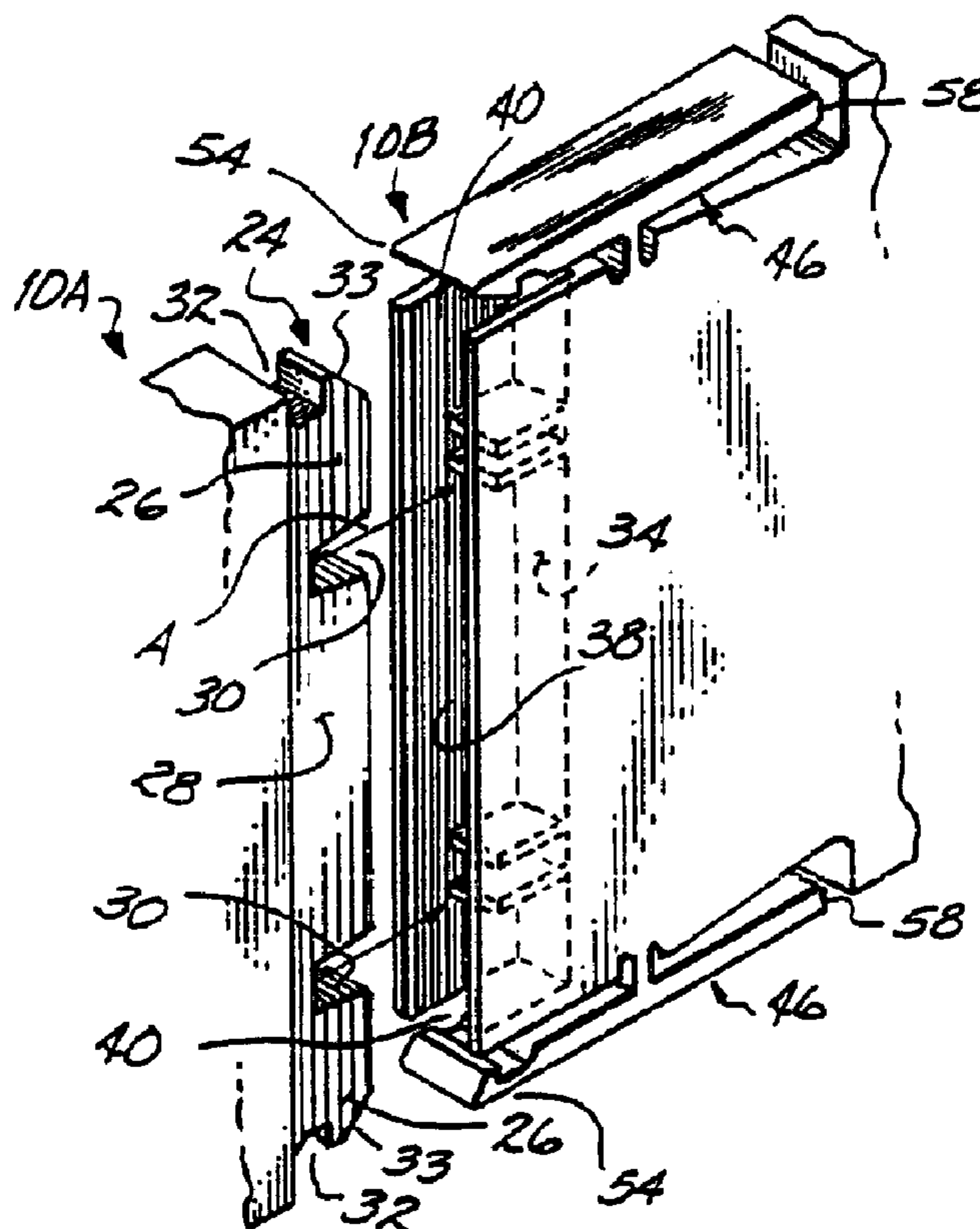

(86) Date de dépôt PCT/PCT Filing Date: 1994/06/15
 (87) Date publication PCT/PCT Publication Date: 1995/01/12
 (45) Date de délivrance/Issue Date: 2006/01/24
 (85) Entrée phase nationale/National Entry: 1995/11/16
 (86) N° demande PCT/PCT Application No.: US 1994/006797
 (87) N° publication PCT/PCT Publication No.: 1995/001195
 (30) Priorité/Priority: 1993/06/30 (085,352) US

(51) Cl.Int.⁷/Int.Cl.⁷ A61M 5/168, A61M 39/10, F16M 13/00
 (72) Inventeurs/Inventors:
 FOWLER, JAMES, US;
 PATZER, CHARLES, US;
 NICHOLSON, WARREN, US;
 THOMPSON, WENDELL, US
 (73) Propriétaire/Owner:
 MEDEX, INC., US
 (74) Agent: MACRAE & CO.

(54) Titre : SUPPORT DE RACCORDEMENT D'ELEMENTS MODULAIRES
 (54) Title: MODULAR INTERCONNECTING COMPONENT SUPPORT PLATE



(57) Abrégé/Abstract:

A modular interconnecting component support unit has a rigid plate (14, 160) with a planar face (16, 164) and a male member or rib (24) and a female member or slot (38) extending parallel the plate face but from opposite sides or edges (22, 34) of the plate so that two such units may be slid together while their faces are in planar relationship. Locking arms (46) adjacent the ends (40) of the slots (38) are provided to releasably grip a rib (24) of one unit received in the slot (38) of a second unit. A medical device, such as a reusable portion of a medical pressure transducer (20, 162), may be permanently affixed to the plate face (16, 164).



INTERNATIONAL APPLICATION PUBLISHED UNDER THE PATENT COOPERATION TREATY (PCT)

(51) International Patent Classification 6 :
A61M 5/168, F16M 13/00

A1

(11) International Publication Number: WO 95/01195

(43) International Publication Date: 12 January 1995 (12.01.95)

(21) International Application Number: PCT/US94/06797

(22) International Filing Date: 15 June 1994 (15.06.94)

(30) Priority Data:
08/085,352 30 June 1993 (30.06.93) US

(81) Designated States: AM, AT, AU, BB, BG, BR, BY, CA, CH, CN, CZ, DE, DK, ES, FI, GB, GE, HU, JP, KE, KG, KP, KR, KZ, LK, LU, LV, MD, MG, MN, MW, NL, NO, NZ, PL, PT, RO, RU, SD, SE, SI, SK, TJ, TT, UA, UZ, VN, European patent (AT, BE, CH, DE, DK, ES, FR, GB, GR, IE, IT, LU, MC, NL, PT, SE), OAPI patent (BF, BJ, CF, CG, CI, CM, GA, GN, ML, MR, NE, SN, TD, TG).

Published

*With international search report.
Before the expiration of the time limit for amending the claims and to be republished in the event of the receipt of amendments.*

(71) Applicant: MEDEX, INC. [US/US]; 3637 Lacon Road, Hilliard, OH 43026 (US).

(72) Inventors: FOWLER, James; 4835 Augustus Court, Hilliard, OH 43026 (US). PATZER, Charles; 1572 Spruce Drive, Columbus, OH 43217 (US). NICHOLSON, Warren; 6375 Phoenix Park Drive, Dublin, OH 43017 (US). THOMPSON, Wendell; 5968 Ulster Drive, Dublin, OH 43017 (US).

(74) Agents: GROSSMAN, Kurt, L. et al.; Wood, Herron & Evans, 2700 Carew Tower, Cincinnati, OH 45202 (US).

2163117

(54) Title: MODULAR INTERCONNECTING COMPONENT SUPPORT PLATE

(57) Abstract

A modular interconnecting component support unit has a rigid plate (14, 160) with a planar face (16, 164) and a male member or rib (24) and a female member or slot (38) extending parallel the plate face but from opposite sides or edges (22, 34) of the plate so that two such units may be slid together while their faces are in planar relationship. Locking arms (46) adjacent the ends (40) of the slots (38) are provided to releasably grip a rib (24) of one unit received in the slot (38) of a second unit. A medical device, such as a reusable portion of a medical pressure transducer (20, 162), may be permanently affixed to the plate face (16, 164).

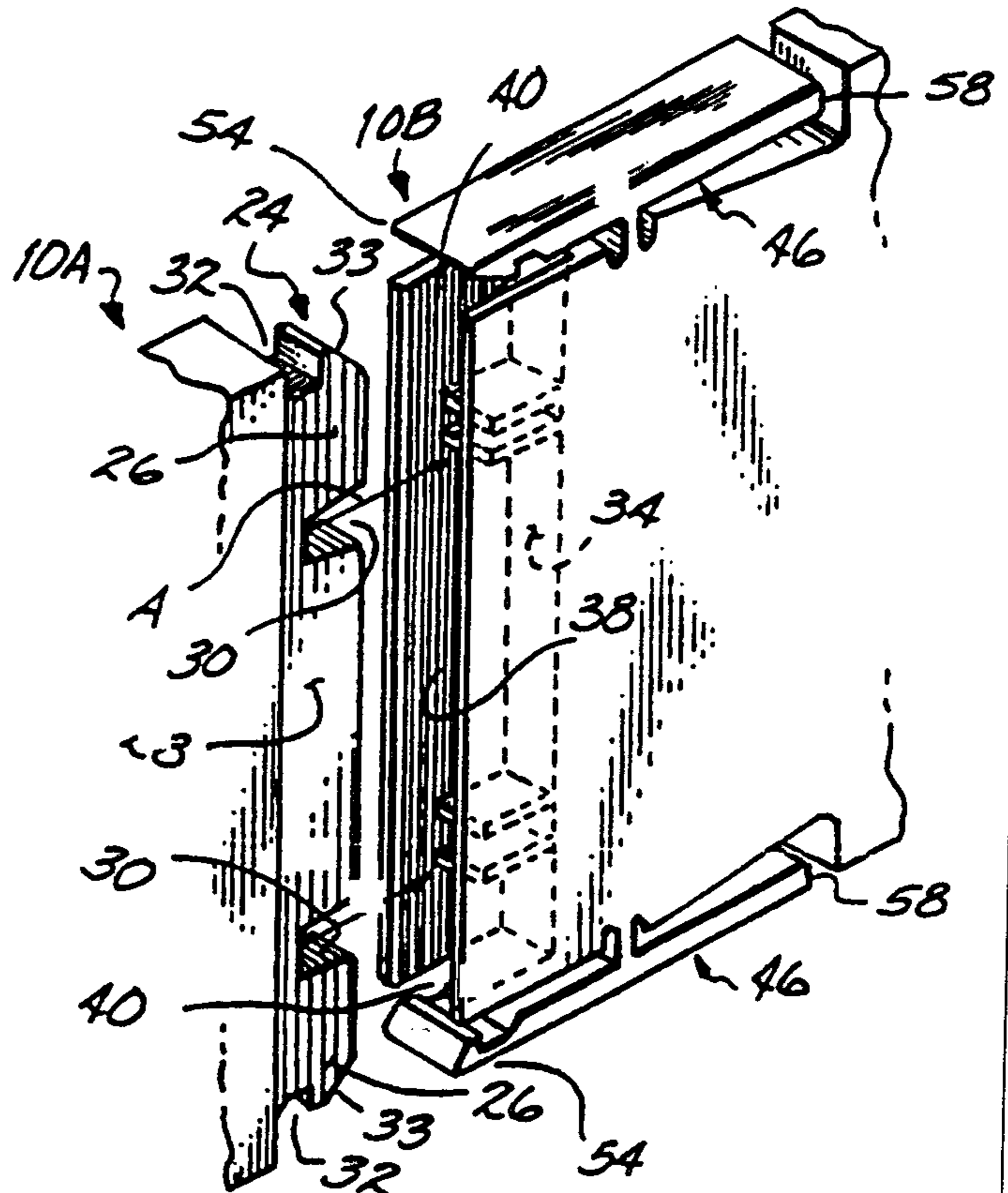

2163117

- 1 -

MODULAR INTERCONNECTING COMPONENT SUPPORT PLATE

BACKGROUND OF INVENTION

I. Field of the Invention

The present invention relates to modular medical pressure transducers.

II. Description of Prior Art

In hospital environments, for example, many procedures involve inserting one or more catheters into a patient with lengths of tubing extending therefrom. Connected to the tubing may be a variety of medical devices such as transducers, flush valves, stop cocks and the like. The tubing may become entangled, making it difficult for medical providers who need to use the devices to access them as needed. To organize the tubing and medical devices for quicker and safer access by medical personnel, and to additionally protect the devices from damage, it has been found to be beneficial to hold the devices to a mounting plate, which is in turn secured to an intravenous pole or other nearby structure. The mounting plates have a flat face with one or more

AMENDED SHEET

-2-

receptacles formed thereon for holding the various medical devices at the ready.

While the use of mounting plates is advantageous, the number of medical devices to be supported may vary depending upon the needs of the patient. In some cases, a mounting plate having one receptacle may be all that is needed. In other cases, mounting plates capable of supporting two or more devices may be desired. Thus, the size of the plate needed may vary from patient to patient resulting in hospitals keeping several different sizes of mounting plates (i.e., with different numbers of receptacles) readily available.

One proposal to eliminate mounting plates of different sizes is a modular system of interlocking plates, each plate having its own receptacle for supporting a device, and structure to lock the plates to one another to simulate a larger plate having multiple receptacles. Such a system permits medical personnel to form any size plate necessary depending upon the medical needs of the patient. While such an interlocking system is desirable, a current modular system is considered to be clumsy in operation. For example, tubing may become tangled due to the offsetting of the plate faces as they are connected together. Similarly, the plates are difficult to separate and thus present not only inconvenience to medical providers but also could result in the tearing of a glove, for example, placing the user at risk of injury.

- 3 -

International Patent Publication W093/10835 published June 10, 1993 describes a system for interlocking a plurality of interchangeable modules in a row with not more than one module on either side of a "centre" module. The "centre" module is mounted on a pole stand. The modules may be medical instrument modules, for example, infusion pumps or patient monitoring units and comprise a frame enclosing the medical instruments with interlocking means on either side to allow connection to another module.

U.S. Patent 4970900 describes a modular system for mounting one or more medical devices on an IV pole. The system includes a support plate and one or more support receptacles, each detachably connectible to the plate and to a medical device. The preferred and illustrated medical device is a disposable pressure transducer. The transducer is provided with tabs which are received in slots in a receptacle whereby to make the connection therebetween. The transducer includes a flow-through chamber for fluid to be monitored, the fluid pressure being transmitted by an insulating medium to a second chamber which houses a diaphragm deflectable in response to pressure impulses in the fluid and operable to produce electrical signals indicative of the pressure impulses. The Patent describes that such disposable transducers are known as reusable transducers including a diaphragm which indirectly monitors IV fluid pressure variations via a disposable diaphragm positioned contiguously therewith and forming part of a disposable dome which acts as a reservoir for the IV fluid. A reusable transducer of this type is disclosed in the Applicants' prior International Publication W090/06722 published June 28, 1990.

- 3 a -

In accordance with one aspect of the invention, a medical pressure transducer module for use with a disposable medical pressure transducer dome which has a disposable diaphragm in pressure communication with the interior of said dome and at least one edge disposed to one side of said diaphragm, the module being reusable and having a support member, a sensor associated with the support member, and a reusable diaphragm in pressure communication with the sensor, characterised in that the sensor is permanently associated with the support member and in that at least one channel member is associated with the support member and configured matingly to receive the edge of the dome such that the channel member brings the disposable diaphragm into confronting pressure transmitting relationship with the reusable diaphragm on mating reception of the edge therein.

In accordance with another aspect of the invention, a medical pressure transducer for use with a disposable medical pressure transducer dome which has a disposable diaphragm in pressure communication with the interior of said dome, the module being reusable and having a support member, a sensor associated with the support member, and a reusable diaphragm in pressure communication with the sensor, the module further being adapted to mate with the dome such that the disposable diaphragm is in confronting pressure transmitting relationship with the reusable

2163117

- 3b -

diaphragm, characterised in that the sensor is permanently associated with the support member and in that the module includes means associated with the support member for attaching the module directly to a pole-clamping mechanism or the like.

The system provides user convenience. A medical device, specifically a reusable transducer, is built directly into or permanently affixed onto a modular member, suitably a plate, thereby eliminating the need for the user

AMENDED SHEET

to couple the device to the plate, thus reducing the possibility that the device will come away from the plate in use. With two-part medical transducers having a disposable fluid dome with a reusable transducer housing, the two parts must be put together with the respective diaphragms thereof in confronting engagement, and the reusable housing mounted in turn to the mounting plate. The system eliminates one of those steps, and reduces the risk that the assembled dome/housing unit may separate from the mounting plate, by providing the reusable portion in permanent association with the modular plate.

In a preferred embodiment, an aperture is formed through the face of the plate and the reusable diaphragm held thereacross. The sensor of the transducer is affixed behind the diaphragm and placed in communication therewith to fully perform the function of the reusable transducer housing. The receptacle structure on the face of the plate is configured to receive a disposable fluid dome with its diaphragm in confronting engagement with the diaphragm held by the plate face.

In addition, in another aspect, there is provided a modular interconnecting component support plate system which overcomes drawbacks associated with the current modular system by the use of modular plates which may be easily and quickly connected together to form variable size plates and may just as easily and quickly be separated into the individual modules, all without unnecessarily tangling

AMENDED SHEET

the tubing or exposing medical providers to injury or inconvenience. To this end, each modular mounting plate is provided with a male web such as a rib running along one side edge of the plate and a female receptacle slot (for receiving the rib from a similar unit) running along the opposite side edge, with the sidewalls defining the slot and the rib extending from the plate in opposite directions, but parallel to the face of the plate. As a result, the rib of one plate is slidably receivable into the slot of another plate while the faces are maintained in generally the same plane rather than offset from one another.

The rib and slot cooperate to connect the plates such that they simulate a conventional multiple receptacle plate. Formed within the slot may be one or more rib stops which cooperate with recesses formed in the rib to prevent the rib from sliding up and down within the slot. To hold the two plates together, locking arms are mounted adjacent each lateral end of the slot to grip the lateral ends of the rib received therein.

A plurality of such plates may be releasably interconnected together into a system capable of supporting any desired number of devices by merely sliding or clipping the rib of one plate into the slot of another until the rib ends engage the locking arms. To release the units, the locking arms are manipulated to release the rib and allow the plates to be slid apart. The locking arms are advantageously mounted in lever-like fashion

between the side edges and along the top and bottom edges of the plate, with the distal gripping ends positioned over the ends of the slot. By pressing the proximal ends of the locking arms towards the plate the distal ends pivot away from the slot, thereby freeing the rib and allowing two connected plates to be simply and readily slid apart. By thus positioning the locking arms, the plates are easily connected together and taken apart without undue inconvenience or risk of injury to the users.

To further enhance use of the system, a portion of the top and bottom edges _____ of the plate may be recessed with the locking arms received in the recesses so that the outer sides of the locking arms are generally flush with the nonrecessed portion of the top and bottom plate edges. As a result, there is a reduced risk of exposure to edges that might otherwise snag the glove of a user, for example.

By virtue of the foregoing, there is thus provided a system of modular interconnecting component support plates that may be easily, quickly and reliably connected to and disconnected from a number of similar such plates to form a mounting plate able to support a number of devices without the need and cost associated with storing mounting plates of differing sizes. Additionally, the resulting composite plate may be separated into its individual modular mounting plates as easily, quickly and reliably as it was assembled.

2163117

- 6a -

Still further, by the permanent inclusion of a medical device with a modular plate, the use is advantageously simplified. Specifically by incorporating the reusable portion _____

of a medical transducer directly into the modular mounting plate, the complexity and time required to secure the transducer assembly to the mounting plate is reduced as is the risk of damage to the transducer unit.

These and other objects and advantages of the present invention shall become apparent from the accompanying drawings and the detailed description thereof.

BRIEF DESCRIPTION OF THE DRAWINGS

The accompanying drawings, which are incorporated in and constitute a part of this specification, illustrate embodiments of the invention and, together with a general description of the invention

AMENDED SHEET

given above, and the detailed description given below, serve to explain the principles of the invention.

Fig. 1 is a front perspective view of a modular mounting plate in accordance with the principles of the present invention and shown attached to a pole;

Fig. 2 is a rear perspective view of the modular mounting plate of Fig. 1;

Fig. 3 is an enlarged front view of a locking arm of the mounting plate of Fig. 1;

Fig. 4 is a diagrammatic view describing the ease of interconnecting and disconnecting the mounting plates of Fig. 1;

Fig. 5 is a schematic plan view of three modular plates of Fig. 1 interconnected into a single assembly;

Fig. 6 is a front perspective view of another mounting plate in accordance with the principles of the present invention shown with the reusable portion of a medical transducer permanently attached thereto; and

Fig. 7 is a rear perspective view of the mounting plate of Fig. 6;

Fig. 8 is a cross-sectional side view of an alternative mounting arrangement of the reusable transducer portion of the plate Fig. 6;

Fig. 9 is a perspective view of an alternative attachment structure to secure a fluid dome to the plate of Fig. 6;

Fig. 10 is a perspective view of another alternative attachment structure to secure a fluid dome to the plate of Fig. 6;

-8-

Fig. 11 is a perspective view of a modified plate to receive a fluid dome; and

Fig. 12 is a perspective exploded view of a medical device permanently affixed to a modular plate in accordance with the principles of the present invention.

DETAILED DESCRIPTION OF THE DRAWINGS

With reference to Figs. 1 and 2, there is shown a modular mounting plate 10 attached to an intravenous pole 12 (Fig. 1) for supporting devices as will be described.

Mounting plate 10 comprises a rigid plate 14 having a generally planar front face 16 with a receptacle 18 thereon to support a device such as a transducer 20 (see Fig. 5). Extending along the length of right side edge 22 of plate 14 is a rib 24 having a width of about 0.15 inches that extends outwardly from edge 22 about 0.37 inches in a direction generally parallel to face 16. Rib 24 includes upper and lower segments 26, and middle segment 28 defined between recesses 30. The outer ends of upper and lower segments 26 have notches 32 behind cam faces 33 for a purpose to be described hereinafter. Extending along the length of the left side edge 34 of plate 14 are sidewalls 36 extending outwardly about 0.37 inches in a direction generally parallel to face 16 thereby defining a slot 38 having open ends 40. Sidewalls 36 are spaced apart about 0.38 cm (0.15 inches) to snugly receive therebetween a rib 24 from another mounting plate 10 to prevent the plates 10 from racking when they are interconnected. Protruding from the edge 34 (which

-9-

also defines the floor of slot 38) are one or more rib stops
42 that fit into recesses 30 in rib 24 to prevent rib 24
from sliding longitudinally within slot 38 when two plates
are interconnected. Rib stops 42 may merge with sidewalls
5 36 and be slotted as at 44 for ease of production.

Locking arms 46 are provided to lock two plates 10
together. Arms 46 are pivotally connected by pivot member 48
in well 49 of intermediate top edge 50 and intermediate
bottom edge 52 of plate 14 (see Fig. 3). The distal end 54
10 of each arm 46 extends over a respective open end 40 of slot
38 with detent 56 of distal end 54 facing into slot 38. As
the rib 24 of one plate 10 slides laterally into slot 38
along a path identified by arrow A in Fig. 4, detents 56
ride over cam faces 33 on the ribs 24 and snap into notches
15 32 to securely lock the plates together (see Fig. 5). To
unlock the plates, proximal end 58 of locking arms 46 are
depressed to pivot the distal ends 54 outwardly from their
respective edges 50 or 52 and slot 38, thereby disengaging
detents 56 from notches 32, whereby one plate may be slid
20 free of the other in a direction opposite arrow A (see Fig.
4).

Right edge 22 of plate 14 is longer than left edge 34.
For example, edge 22 may be about 7.5 cm (3.0 inches) long
whereas edge 34 is about 6.6 cm (2.6 inches) long. This size
25 relationship provides some useful advantages. For example,
upper and lower segments 26 of rib 24 extend beyond open
ends 40 of slot 38 thereby permitting the locking arm
detents 56 to engage the rib notches 32. Similarly, the

-10-

areas 60 of top and bottom edges 50, 52, in which locking arms 46 are located, provide a recess such that outer surface 62 of each locking arm 46 is substantially co-extensive with the nonrecessed portion 64 of the respective top or bottom edge 50 or 52 of the plate. As a consequence, exposure to edges is reduced. Surfaces 62 may each include a plurality of rumple strips 65 formed thereon to facilitate finger gripping. Note also that the area 60 adjacent right edge 22 is angled downwardly to align with the proximal ends 58 of locking arms 46 when they are depressed.

As is conventional, support structure such as a receptacle 18 is formed in plate face 16 as seen in Fig. 1. Receptacle 18 comprises a pair of confronting channels 66 spaced about 2.60 cm (1.02 inches) apart and formed by L-shaped walls 68 extending forwardly from plate face 16, and an outer wall 70 connected to the distal edge of each wall 68. The wings of a device to be held by plate 10 (such as wings 72 of transducer 20 seen in Fig. 5) are slidably fit into channels 66 through open ends 74 until resting against the bottom ledge 76 of wall 68. A pair of raised dimples 78 protrude forwardly from the plate face 16 between opposed channels 66 and bear against the mounted device to help hold it to mounting plate 10. Slots 80 and 81 may be provided through plate 14 beneath opposed channels 66. While a conventional receptacle 18 is shown, it will be appreciated that many other structures including, by way of example, opposed resilient clips or tabs, may be used to secure the devices to the mounting plate 10.

-11-

To hold plate(s) 10, each mounting plate 10 also includes a shelf 82 extending from the upper half of the back side 84 of rigid plate 14 (see Fig. 2). Shelf 82 may be used to secure the mounting plate 10 to an intravenous pole 12 or other external structure by way of clamping mechanism 85 as is well known in the art. As seen readily in Fig. 2, an upwardly facing hook 86 is molded into the back side of plate 14 near bottom edge 52 for suspending a solution reservoir (not shown), for example, from mounting plate 10. A slot 87 may be formed through plate 14 adjacent hook 86. A rectangular depression 88 may be formed in plate face 16 (Fig. 1) for attaching a label or other identification to the mounting plate 10.

In use (see Fig. 4), two mounting plates 10 are easily interconnected by sliding rib 24 of a first plate 10A into slot 38 of a second plate 10B laterally in the direction rib 24 extends from its rigid plate 14 as indicated by arrow A until detents 56 snap into rib notches 32 to thus rigidly, but releasably interlock mounting plates 10A, 10B together. Additional plates (e.g., 10C) may be locked to one of the first two (e.g., 10B) in similar fashion (see, e.g., Fig. 5) to thus provide a simulated single plate having as many support receptacles as needed. The device to be supported (e.g., transducer 20) may be mounted onto receptacles 18 before or after the plates are snapped together as desired. To separate the mounting plates, the proximal ends 58 of locking arms 46 are depressed towards the top and bottom edges 50, 52 while the units are simply slid apart in the opposite direction of their insertion. Thus, in

any number of mounting plates may be quickly and easily interconnected to form a system capable of supporting any desired number of devices. Additionally, the system may be easily, quickly and reliably separated into its individual mounting plates with minimal risk of exposure to edges and without the difficulty associated in a prior modular system.

With reference to Figs. 6 and 7, there is shown a modular system which incorporates, in generally permanent fashion, a medical device therewith. By way of example, mounting plate 10' is similar to plate 10 but has the reusable portion of a medical device, such as a transducer 20, formed directly into rigid plate 14. To this end, and by way of example, rigid plate 14 has an aperture 102 formed therethrough with diaphragm 104 affixed to plate face 16 across aperture 102. A transducer sensor 106 is secured to rigid plate 14 behind aperture 102 and placed into communication with diaphragm 104, such as via a gel-filled recess, to fully perform the function of a reusable transducer portion. Wires 105 extend from sensor 106 to be coupled to a monitor (not shown). Sensor 106 may alternatively have electrical connectors extending therefrom for releasable attachment to a cable coupled to the monitor. The construction of sensor 106 and diaphragm 104 into a transducer may be as disclosed in U.S. Patent

- 13 -

No. 4,920,972 of May 1, 1990.

To use sensor 106, reusable diaphragm 104 is to be placed into confronting engagement with the diaphragm 108 of a disposable fluid dome 110 (diaphragm 108 is secured to dome 110 but is shown separated therefrom in Fig. 6 for explanatory purposes). To this end, support structure is provided by a pair of slots 112 parallel to right and left side edges 22 and 34 of rigid plate 14 and extending through rigid plate 14 on opposing sides of aperture 102. Slots 112 are sized and positioned to receive locking arms 114 pivotally connected by pivot member 116 to fluid dome 110. Arms 114 have inwardly facing hooks 120 thereon. As locking arms 114 are inserted into slots 112, hooks 120 ride over inner edges 124 of slots 112, and when disposable dome diaphragm 108 is in confronting engagement with the reusable portion diaphragm 104, hooks 120 emerge through rigid plate 14 and locking arms 114 resume their undeformed shape thereby securely locking disposable portion 110 to mounting plate 10'.

To remove disposable portion 110, proximal ends 122 of locking arms 114 are inwardly depressed to pivot the distal ends 120 outwardly, thereby disengaging hooks 120 from the slot inner edges 124 whereby dome 110 may be slid free of the mounting plate 10'. Thus, in accordance with the present invention, a modular mounting plate incorporating the reusable portion of a medical device,

-14-

such as a transducer, is provided that can easily and quickly receive the disposable portion thereof, and which can additionally be interlocked with any number of similar mounting plates to provide a system capable of holding any
5 desired number of devices.

As shown in Fig. 8, diaphragm 104 may alternatively extend across lip 130 of gel-filled cavity 132 contained within sensor housing 134. Recess 136 in the rigid plate back side 84, which is slightly larger in
10 diameter than aperture 102, is sized to receive the sensor/diaphragm assembly such that shoulder 138 of recess 136 cooperates with housing 134 to hold diaphragm 104 to housing 134. Sensor housing 134 is fixedly secured to rigid plate 14 by ultrasonic welding or by applying
15 adhesive to exposed surface 140 of the housing prior to pushing the housing against back side 84 of rigid plate 14. After securing the sensor/diaphragm assembly to the mounting plate, and after curing of the gel in cavity 132 as described in the aforementioned U.S. Patent No.
20 4,920.972, diaphragm 104 bulbously protrudes through aperture 102 for communication with the diaphragm of a disposable fluid dome. Although Fig. 8 shows diaphragm 104 fixedly secured between sensor housing 134 and rigid plate 14, it will be appreciated by those skilled in the
25 art that lip 130 may protrude through aperture 102 and forwardly thereof with diaphragm 104 fixedly secured across and solely to lip 130. Thus, sensor housing 134 and diaphragm 104 may protrude through aperture 102 and

-15-

forwardly of face plate 16 such that diaphragm 104 is still accessible from the face of the plate in accordance with the principles of the present invention.

It will be appreciated that other structures for
5 releasably attaching a disposable medical device (e.g., a transducer dome) to the mounting plate may be used. For example, locking arms 114 could be extended as at 114' to substantially the length of slots 112 as shown in Fig. 9. For this purpose, pivot members 116 are replaced with
10 connecting plate 116'.

Alternatively, a "ski-boot" foot and latching arm structure may be used as shown in Fig. 10. To this end, mounting plate 10' and reusable portion diaphragm 104 remain unchanged from that described above. However, the
15 locking structure of disposable fluid dome 110 is replaced with an outwardly facing L-shaped foot 150 connected to one side of connecting plate 116" and extending forwardly therefrom, and an extended length latch member 114" on the other side of connecting plate 116", which is the same as
20 that described above but with a lever arm 152 attached thereto for a purpose to be described. To secure fluid dome 110 to mounting plate 10', dome 110 is pivoted onto its side so that the free end 154 of foot 150 may be inserted into one of slots 112. Fluid dome 110 is then
25 pivoted towards plate face 16 until latching member 114" locks into the other slot 112 thereby placing the respective diaphragms in confronting engagement. To remove the disposable fluid dome 110 of Fig. 10, lever arm

- 16 -

152 is lifted to disengage latch member 114" from mounting plate 10' and fluid dome 110 is pivoted, whereby foot 150 may be removed from slot 112 and fluid dome 110 lifted from mounting plate 10'. Although the locking structure of fluid dome 110 in Figs. 9 and 10 is shown with connecting plate 116' and 116" extending from the top of fluid dome 110, it will be readily appreciated that the connecting plate 116' could be formed along the side or from the bottom of the fluid dome.

With reference to Fig. 11, receptacle 18 (i.e., channels 66) could be employed, as described in connection with Fig. 1, to secure fluid dome 110 to mounting plate 10". To this end, fluid dome 110 is constructed with bottom-mounted plate 156 that defines wings 158 for slidable engagement with channels 66 to hold the respective diaphragms 104, 108 into confronting engagement.

Referring to Fig. 12, a modular plate 160 is _____ shown having a medical device 162 permanently affixed to the face 164 of plate 160. Plate 160 may be the same as plates 10 and 10', except that face 164 may be solid without either slots or a receptacle. To this end, a medical device 162, such as a disposable pressure transducer, is fixedly adhered to solid front face 164 such as by way of adhesive 166 resulting in a generally permanent unitary structure. The plate with the medical device affixed thereto may be interconnected with other

AMENDED SHEET

mounting plates (with or without permanently affixed
medical devices). After use, the entire plate 160 is
discarded. Although Fig. 12 shows medical device 162
secured to plate 160 by way of adhesive 166, it will be
5 readily appreciated that other means of permanently
including a medical device with the mounting plate may be
used.

Also, the reusable portion of a two-part
transducer could be formed on or adhered to the plate with
10 the dome being removably affixed thereto by a threaded
quarter-turn arrangement (not shown).

In manufacturing the mounting plates 10, 10',
10" and 160, any suitable plastic such as polycarbonate
may be used in the molding process. Additionally, it
15 would be desirable to mold the mounting plate as a single
component, although a multi-component mounting plate would
be within the principles of the invention. To create the
single modular unit out of plastic, it will be appreciated
that plate 14 should not be too thick. Thus, the top and
20 side edges may actually be walls extending from face 16 as
seen in Fig. 2.

By virtue of the foregoing, there is thus
provided a modular interconnecting component mounting
plate that may be easily and quickly connected with
25 similar units to form a plate capable of supporting a
number of devices, and which is easily separated into its
constituent components for storage and reuse.

2163117

- 18 -

While the different embodiments have been described in considerable detail, additional advantages and variations will readily appear to those skilled in the art. For example, a mounting plate 10 including one or no locking arms 46 may be used and still fall within the principles of the present invention. With such a system, the mounting plates 10 are interconnected through a friction fit between the rib 24 and slot 38 of similar units. Additionally, a mounting plate 10 in which the rib middle segment 28 is removed will function within the principles herein. Also, where the medical device is permanently affixed, male-to-female mating structures other than as described herein may be employed.

AMENDED SHEET

CLAIMS

1. A medical pressure transducer module (20) for use with a disposable medical pressure transducer dome (110) which has a disposable diaphragm (108) in pressure communication with the interior of said dome and at least one edge (114, 114', 114", 150, 158) disposed to one side of said diaphragm (108), the module (20) being reusable and having a support member (14, 10', 10"), a sensor (106) associated with the support member (14, 10', 10"), and a reusable diaphragm (104) in pressure communication with the sensor (106), characterised in that the sensor (106) is permanently associated with the support member and in that at least one channel member (66, 112) is associated with the support member (14, 10', 10") and configured matingly to receive the edge (114, 114', 114", 150, 158) of the dome (110) by a linear motion such that the channel member (66, 112) brings the disposable diaphragm (108) into confronting pressure transmitting relationship with the reusable diaphragm (104) on mating reception of the edge (114, 114', 114", 150, 158) therein.

2. A medical pressure transducer module (20) for use with a disposable medical pressure transducer dome (110) which has a disposable diaphragm (108) in pressure communication with the interior of said dome and at least one edge (114, 114', 114") disposed to one side of said diaphragm (108), the module (20) being reusable and having

- 20 -

a support member (14, 10', 10"), a sensor (106) associated with the support member (14, 10', 10"), and a reusable diaphragm (104) in pressure communication with the sensor (106), characterised in that the sensor (106) is permanently associated with the support member and in that at least one channel member (112) is associated with the support member (14, 10', 10") and configured matingly to receive the edge (114, 114', 114") of the dome (110) such that the channel member (112) brings the disposable diaphragm (108) into confronting pressure transmitting relationship with the reusable diaphragm (104) on mating reception of the edge (114, 114', 114") therein, said edge being formed on a latching arm (114, 114', 114") having a hook (120) for releasably locking the disposable dome to the support member when the edge is received in the channel member (122).

3. A module as claimed in Claim 1 or 2 wherein the pressure dome includes a pair of edges (114, 114', 114", 150, 158) disposed to different sides of the dome diaphragm (108), the module being further characterised by a pair of the channel members (66, 112) associated with the support member (14, 10', 10") and disposed to different sides of the reusable diaphragm (104) to matingly receive respective ones of the dome edges (114, 114', 114", 150, 158).

-21-

4. A module as claimed in any one of claims 1 to 3, the channel member defining a slot (112) through the support member (14, 10', 10").

5. A module as claimed in Claim 3 wherein the pressure dome edges extend generally transverse to the disposable diaphragm (108), the channel members being defined by elongated slots (112) in the support member so as to receive respective edges (114, 114', 114", 150) of the pressure dome (110) therethrough.

10 6. A module as claimed in Claim 5 in combination with the disposable dome (110) wherein the edges (114, 144') are pivotally mounted on opposing sides of the dome (110) and are adapted to be received by the pair of slots (112) for releasably locking the disposable dome (110) to the support
15 member (114, 10', 10") thereby placing the disposable diaphragm (108) in pressure communication with the reusable diaphragm (104).

20 7. A module as claimed in Claim 2 in combination with the disposable dome (110), the dome comprising a further edge (150) defined by an outwardly facing L-shaped foot (150) extending forwardly from one side of the dome (110) and adapted to be pivotally received by a slot (112), said further edge (150) and said latching arm (114") being disposed to opposite sides of the dome diaphragm (108).

-22-

8. A module as claimed in Claim 1 wherein the dome edge defines a mounting wing (158) extending to said one side of said dome diaphragm, the channel member defining a channel (66) configured to slidably receive said dome wing so as to slide said dome diaphragm (108) into confronting relationship with the reusable diaphragm (108).

9. A module as claimed in Claim 1 wherein the pressure dome includes a pair of said edges, which are disposed to different sides of the dome diaphragm, which are generally co-planar and which extend outwardly from opposite sides of the disposable diaphragm (108), the channel members each being defined by a channel (66) and being disposed so as to slidably receive respective edges (158) of said pressure dome.

10. A module as claimed in Claim 9 the channels (66) each including an L-shaped wall (68).

11. A module as claimed in Claim 10 further comprising an outer wall (70) associated with each L-shaped wall (68).

12. A module as claimed in any one of claims 1 to 11 further comprising attachment means (82) for mounting the module to an external support (12).

-23-

13. A module as claimed in Claim 12 wherein the attachment means (82) is a shelf (82) integrally formed with the support member.

5 14. A medical pressure transducer module (20) for use with a disposable medical pressure transducer dome (110) which has a disposable diaphragm (108) in pressure communication with the interior of said dome, the module (20) being reusable and having a support member (114, 10', 10"), a sensor (106) associated with the support member (14, 10', 10"), and a reusable diaphragm (104) in pressure communication with the sensor (106), the module further being adapted to mate with the dome (110) such that the disposable diaphragm (108) is in confronting pressure transmitting relationship with the reusable diaphragm (104),
10 characterised in that the sensor (106) is permanently associated with the support member (14, 10', 10") and in that the module includes a shelf (82) integrally formed with the support member (14, 10', 10") for attaching the module (20) directly to a pole-clamping mechanism (85).
15

20 15. A medical pressure transducer module (20) for use with a disposable medical pressure transducer dome (110) which has a disposable diaphragm (108) in pressure communication with the interior of said dome, the module (20) being reusable and having a support member (114, 10',

- 24 -

10"), a sensor (106) associated with the support member (14, 10', 10"), and a reusable diaphragm (104) in pressure communication with the sensor (106), the module further being adapted to mate with the dome (110) such that the
5 disposable diaphragm (108) is in confronting pressure transmitting relationship with the reusable diaphragm (104), characterised in that the sensor (106) is permanently associated with the support member (14, 10', 10"), in that the module includes means (82) associated
10 with the support member (14, 10', 10") for attaching the module (20) directly to a pole-clamping mechanism (85) or the like, and in that the support member includes a rigid plate (14) having a face (16) extending between first and second opposite edges (22, 34) with the reusable diaphragm
15 (104) being associated with the plate face (16), a male member (24) associated with the first edge (22), and a female member (38) associated with the second edge (34) and sized to receive therein the male member (24) of another such module.

20

16. A module as claimed in Claim 15 wherein the plate face (16) is generally planar, the male member is a web or rib (24) extending from the associated plate edge (22) in a direction generally parallel to the plate face (16) and the female member is a receptacle or slot (38)
25 defined by walls (36) extending from the associated plate edge (34) in a direction generally parallel to the plate face (16) such that the male web or rib (24) of a first

- 25 -

such module is slidably receivable into the female receptacle or slot (38) of a second such module while the plate faces (16) thereof are maintained in generally planar relationship.

5

17. A module as claimed in either Claim 15 or Claim 16 further characterised by a stop member (42) within the female member (38) and a recess (30) formed in the male member (24) whereby to prevent longitudinal
10 sliding motion of the male member (24) within the female member (38).

18. A module as claimed in any one of Claims 15 to 17 further characterised by lock means (46) to hold two
15 such modules together.

19. A module as claimed in Claim 18 wherein the plate includes an intermediate edge (50, 52) extending between the first and second edges (22, 34) further
20 characterised in that the lock means (46) includes a locking arm (46) pivotally mounted to the intermediate edge (50, 52) and having a distal portion (54) adjacent the female member (38) and a proximal portion (58) spaced away from the female member (38) and towards the male
25 member (24).

20. A module as claimed in Claim 19 wherein the intermediate edge (50, 52) includes a recessed portion

- 26 -

(60) in which the locking arm (46) is situated whereby to reduce exposure to edges.

21. A module as claimed in Claim 18 further
5 characterised in that the lock means (46) includes at least one locking arm (46) supported on the plate (14) and adjacent a lateral end (40) of the female member (38), the locking arm (46) having structure (56) adapted to grip a lateral end (33) of a male member (24) received in the
10 female member (38).

22. A module as claimed in any one of Claims 19 to 21 further characterised in that the lateral end (40) of the female member (38) is open for a lateral end (33) of the male member (24) to protrude therefrom and the lateral
15 end (33) of the male member (24) has a recess (32) to receive a portion of the locking arm (46) therein.

23. A module as claimed in Claim 18 wherein the
20 plate (14) includes a third edge (50) and a fourth edge (52) intermediate the first and second edges (22, 34) further characterised in that the lock means (46) includes locking structure (46) associated with each of the third and fourth edges (50, 52) and positioned to grip the male
25 member (24) of another such module (10) received in the female member (38).

24. A module as claimed in Claim 23 wherein the

-27-

locking structure (46) includes a pair of pivotable locking arms (46) mounted on the third and fourth edges (50, 52) of the plate (14) with a distal end (54) of each arm (46) extending over the female member (38) and having a finger (56) thereon adapted to fit into the notch (32) of a male member (24) received in the female member (38), and a proximal end (58) of each arm (46) being moveable toward the plate (14) to lift the finger (56) from the notch (32) such that when the male member (24) of one such module is inserted into the female member (38) of another such module in a direction generally parallel to the plate face (16), the locking arm fingers (56) fit into the male member notches (32) to releasably and rigidly interconnect the modules.

25. A module as claimed in Claim 24 further characterised in that the third and fourth edges (50, 52) each include a recessed portion (60) into which the respective locking arm (46) is situated whereby to reduce exposure to edges.

26. A module as claimed in any one of claims 1 to 25 wherein the support member (14, 10', 10") includes an aperture (102) with the reusable diaphragm (104) affixed across the aperture (102).

27. A module as claimed in Claim 26 further including a sensor housing (134) with the reusable diaphragm (104) mounted thereto, further characterised in that the support

-28-

member (14, 10', 10") includes a recess (136) about the aperture (102), the recess (136) and sensor housing (134) cooperating to wedgingly hold the reusable diaphragm (104) to the sensor housing (134).

5 28. A module as claimed in any one of claims 1 to 27, wherein the support member (14, 10', 10") includes peripheral side edges (22, 34, 50, 52) that define a generally rectangular shape and a front face (16) whereat the reusable diaphragm (104) is exposed.

10 29. A medical pressure transducer dome (110) for use with a reusable medical pressure transducer module (20) which has a support member (14, 10', 10"), a pressure sensor (106) permanently associated with the support member (14, 10', 10"), a reusable diaphragm (104) in pressure communication
15 with the sensor (106), and at least one channel member (66, 112) associated with the support member (14, 10', 10") and disposed to one side of the reusable diaphragm (104), the dome (110) being disposable and having a disposable diaphragm (108) in pressure communication with the interior
20 of the dome, characterised in that the dome (110) includes at least one edge (114, 114', 114", 150, 158) disposed to one side of said diaphragm (108) and configured matingly to be received by a linear motion in said channel member (66, 112) of the module (20) such that the edge (114, 114', 114", 150,
25 158) of

- 29 -

the dome (110) brings the disposable diaphragm (108) into confronting pressure transmitting relationship with said reusable diaphragm (104) on mating reception in said channel member (66,112).

5

30. A medical pressure transducer dome (110) for use with a reusable medical pressure transducer module (20) which has a support member (14,10'10"), a pressure sensor (106) permanently associated with the support member (14,10',10"), a reusable diaphragm (104) in pressure communication with the sensor (106), and at least one channel member (112) associated with the support member (14,10',10") and disposed to one side of the reusable diaphragm (104), the dome (110) being disposable and having a disposable diaphragm (108) in pressure communication with the interior of the dome, characterised in that the dome (110) includes at least one edge (114,114',114") disposed to one side of said diaphragm (108) and configured matingly to be received in said channel member (112) of the module (20) such that the edge (114,114',114") of the dome (110) brings the disposable diaphragm (108) into confronting pressure transmitting relationship with said reusable diaphragm (104) on mating reception in said channel member (112), said edge being formed on a latching arm (114, 114', 114") having a hook (120) for releasably locking the disposable dome to the support member when the edge is received in the channel member (122).

25

- 30 -

31. A dome as claimed in Claim 29 or claim 30 wherein said channel member is defined by an elongated slot (112) in the support member, the pressure dome edge (114,114',114") extending generally transverse to the disposable diaphragm (108) so as to be received through a respective slot (112) of the module (20).

32. A dome (110) as claimed in Claim 29 or claim 30 wherein said module includes a pair of said channel members (66,112) disposed to different sides of the reusable diaphragm (104), the dome being further characterised by a pair of the edges (114, 114',114", 150, 158) disposed to different sides of the dome diaphragm (108) to be matingly received in respective ones of said channel members (66,122).

33. A dome as claimed in Claim 32 wherein the channel members are defined by elongated slots (112) in the support member, the pressure dome edges (114,114',114") extending generally transverse to the disposable diaphragm (108) so as to be received through respective ones of the slots (112).

25

34. A dome as claimed in Claim 33 wherein the edges (114,114') are pivotally mounted on opposing sides of the dome (110) to be received by the pair of slots (112) for

- 31 -

releasably locking said disposable dome (110) to the support member (14,10',10") thereby placing said disposable diaphragm (108) in pressure communication with the reusable diaphragm (104).

5

35. A dome as claimed in Claim 30 comprising a further edge (150) defined by an outwardly facing L-shaped foot (150) extending forwardly from one side of the dome (110) to be pivotally received by a slot (112), said further edge (150) and said latching arm (114") being disposed to opposite sides of the dome diaphragm.

36. A dome as claimed in Claim 29 wherein the channel member defines a channel (66), the dome edge defining a mounting wing (158) extending to said one side of said dome diaphragm and configured to be slidably received in said channel so as to slide the dome diaphragm (108) into confronting relationship said reusable diaphragm (108).

20

37. A dome as claimed in Claim 32 wherein the channel members each define a channel (66), the pressure dome edges being generally co-planar and extending outwardly from opposite sides of the disposable diaphragm (108) so as to be slidingly received in respective channels of said module.

25

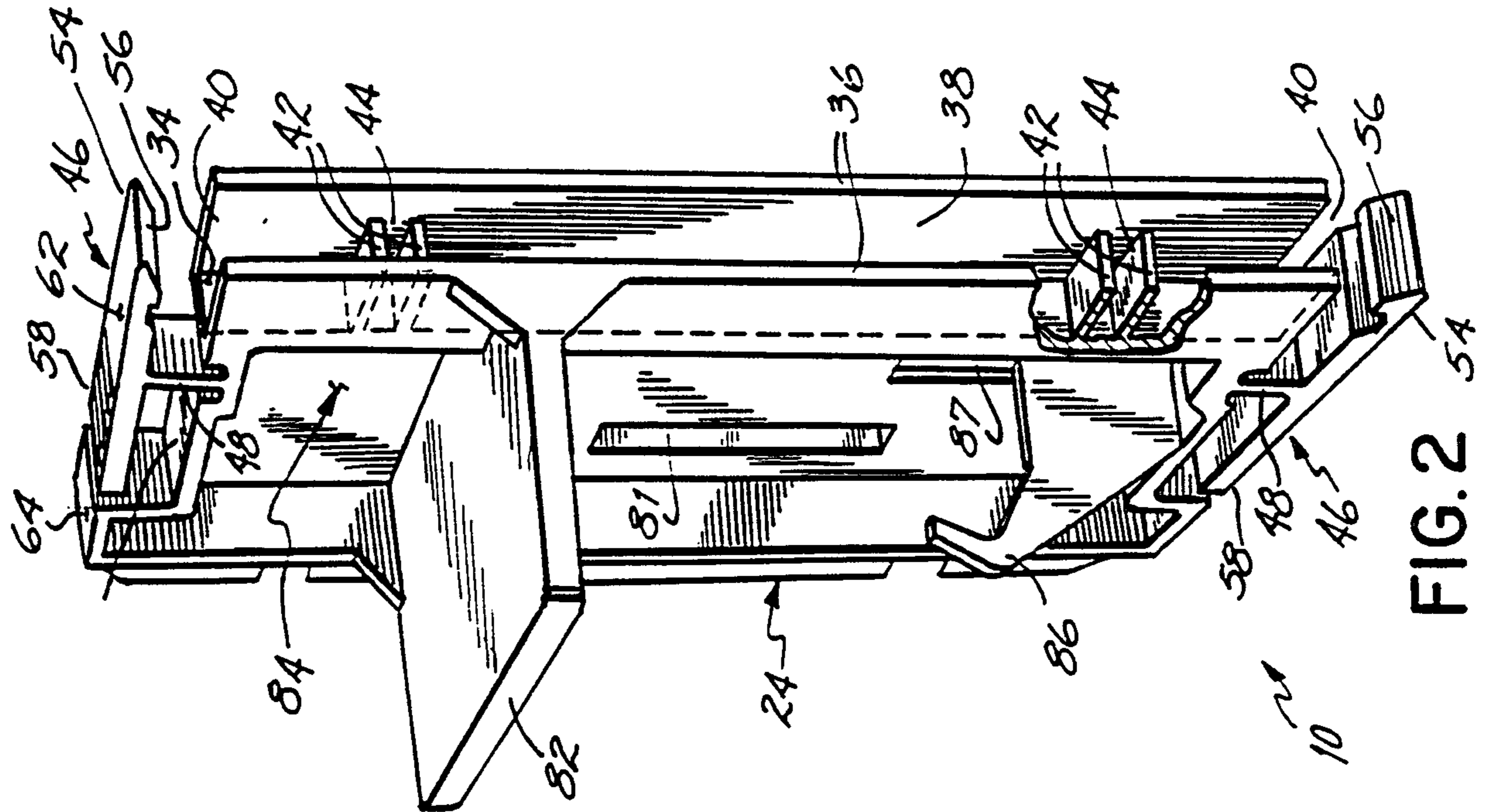

FIG. 2

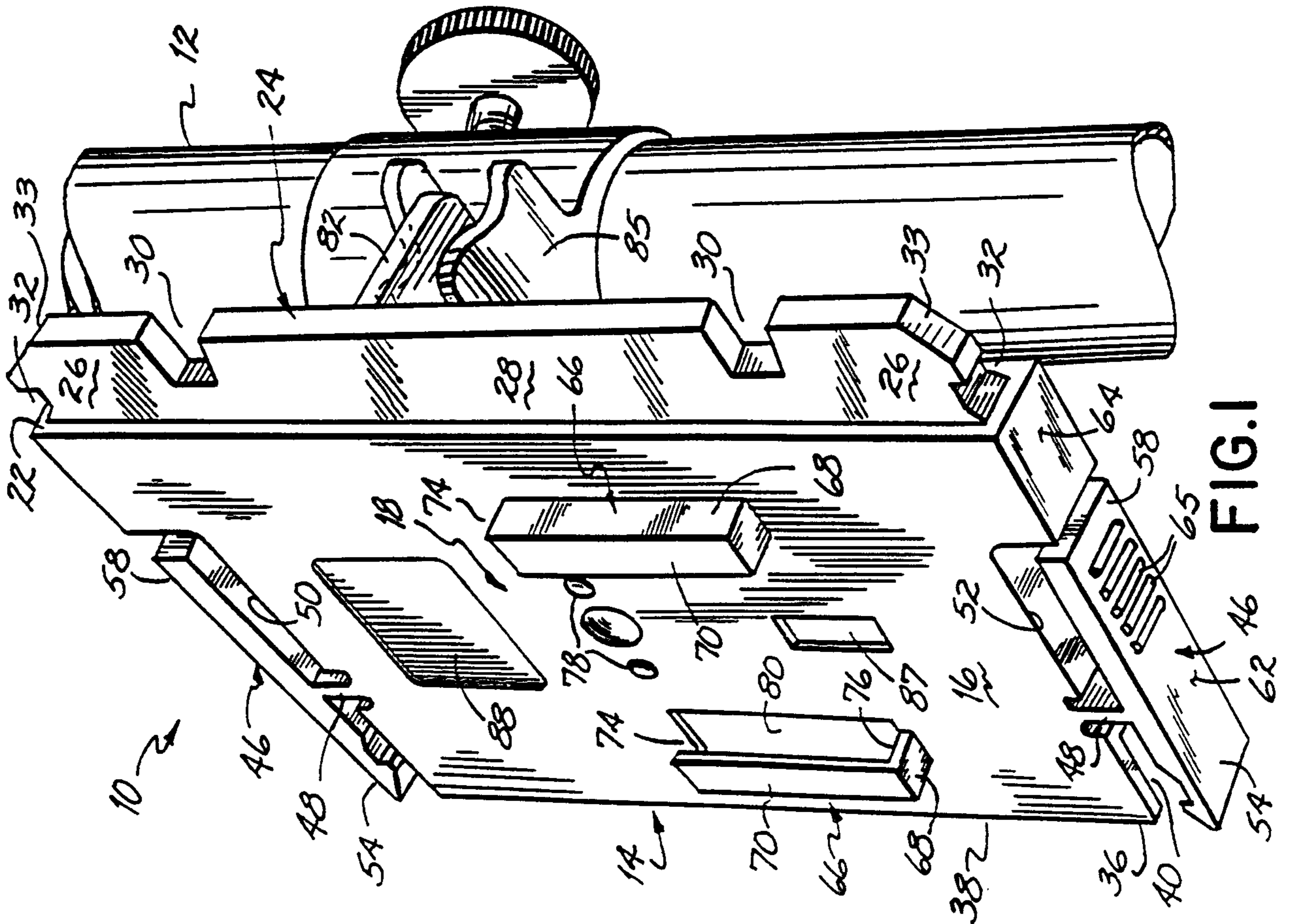

FIG. 1

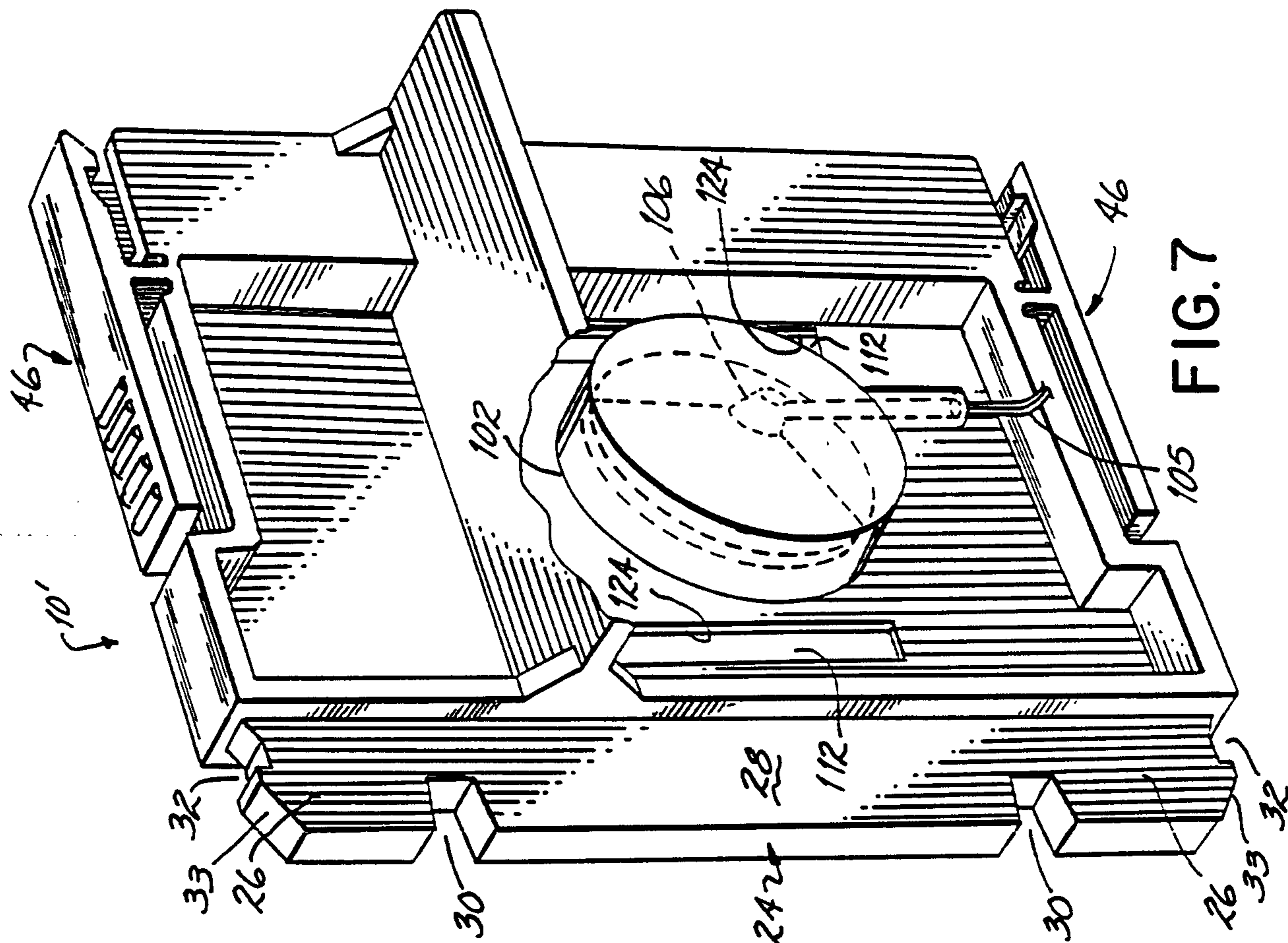

FIG. 7

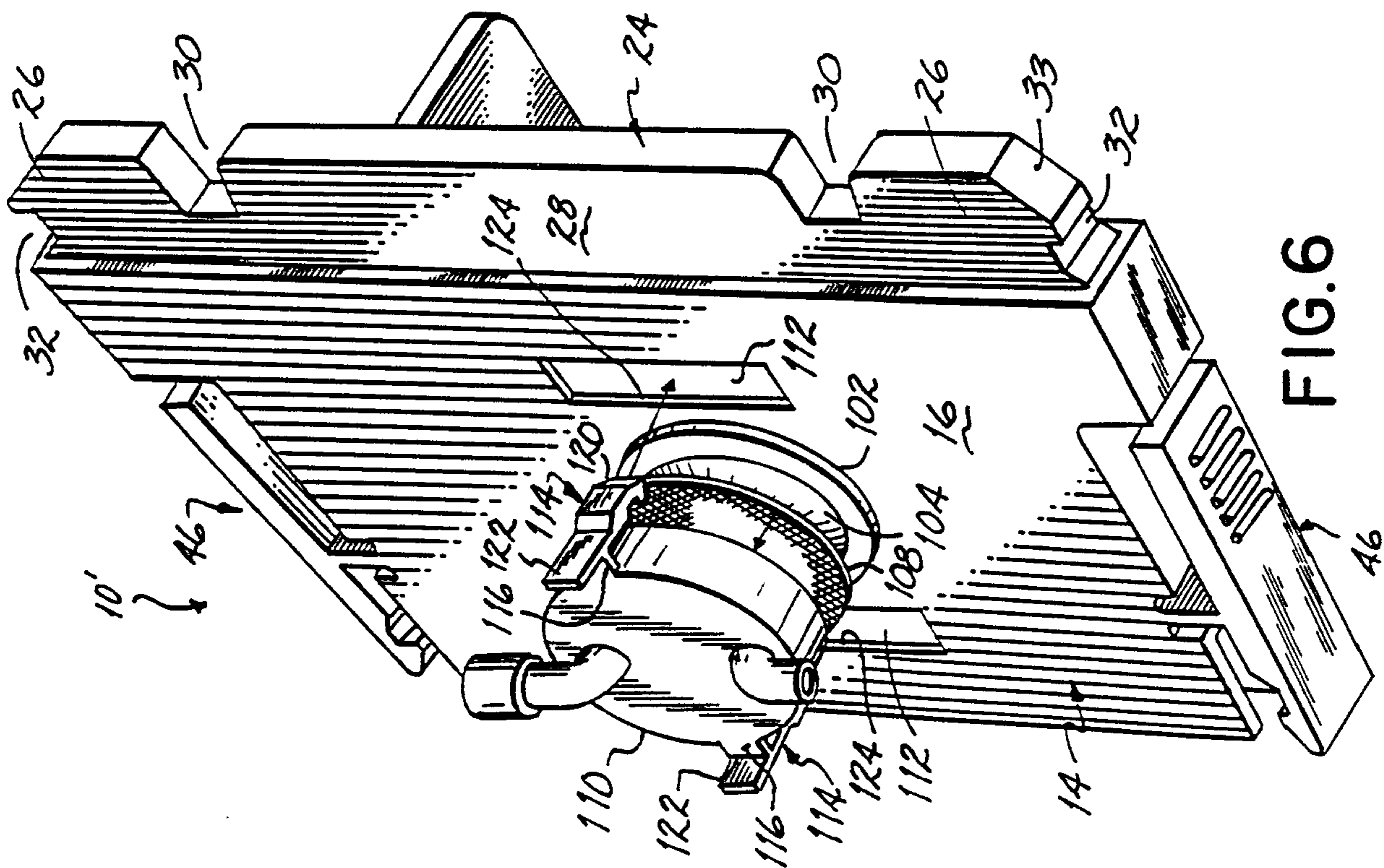

FIG. 6

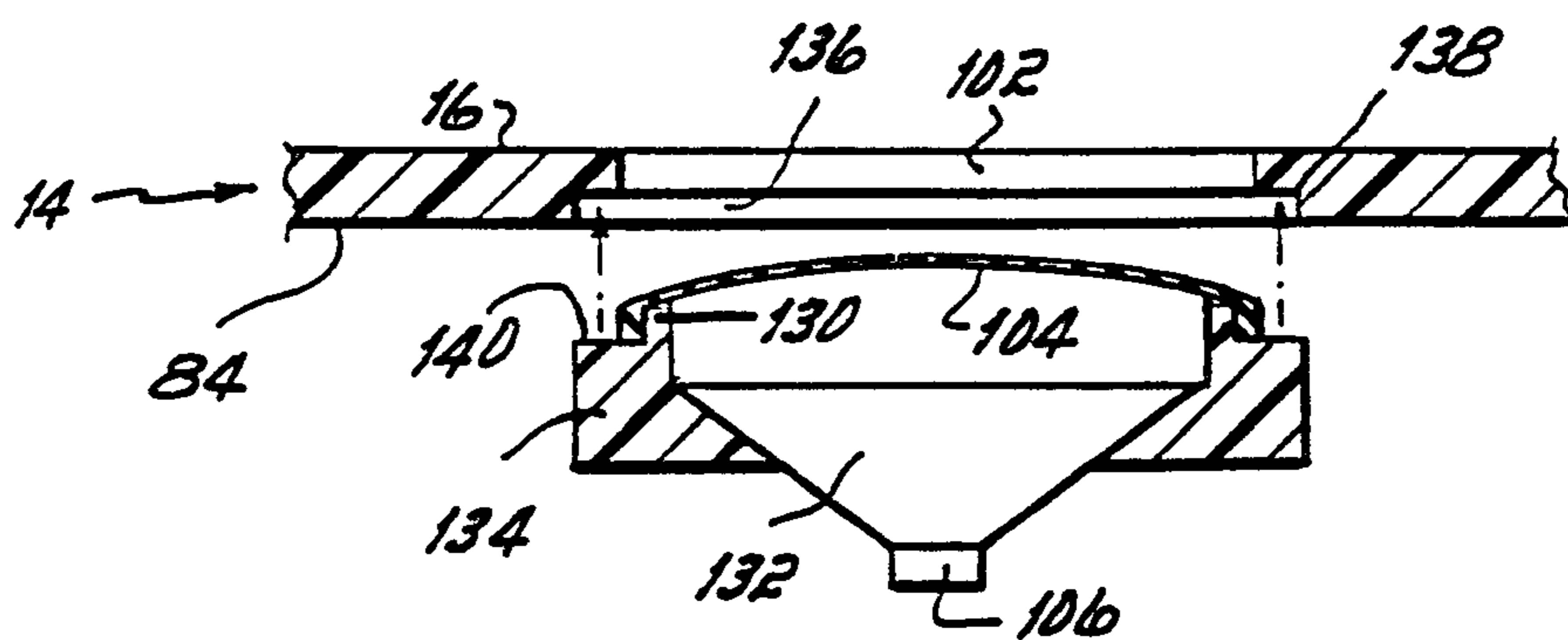

FIG. 8

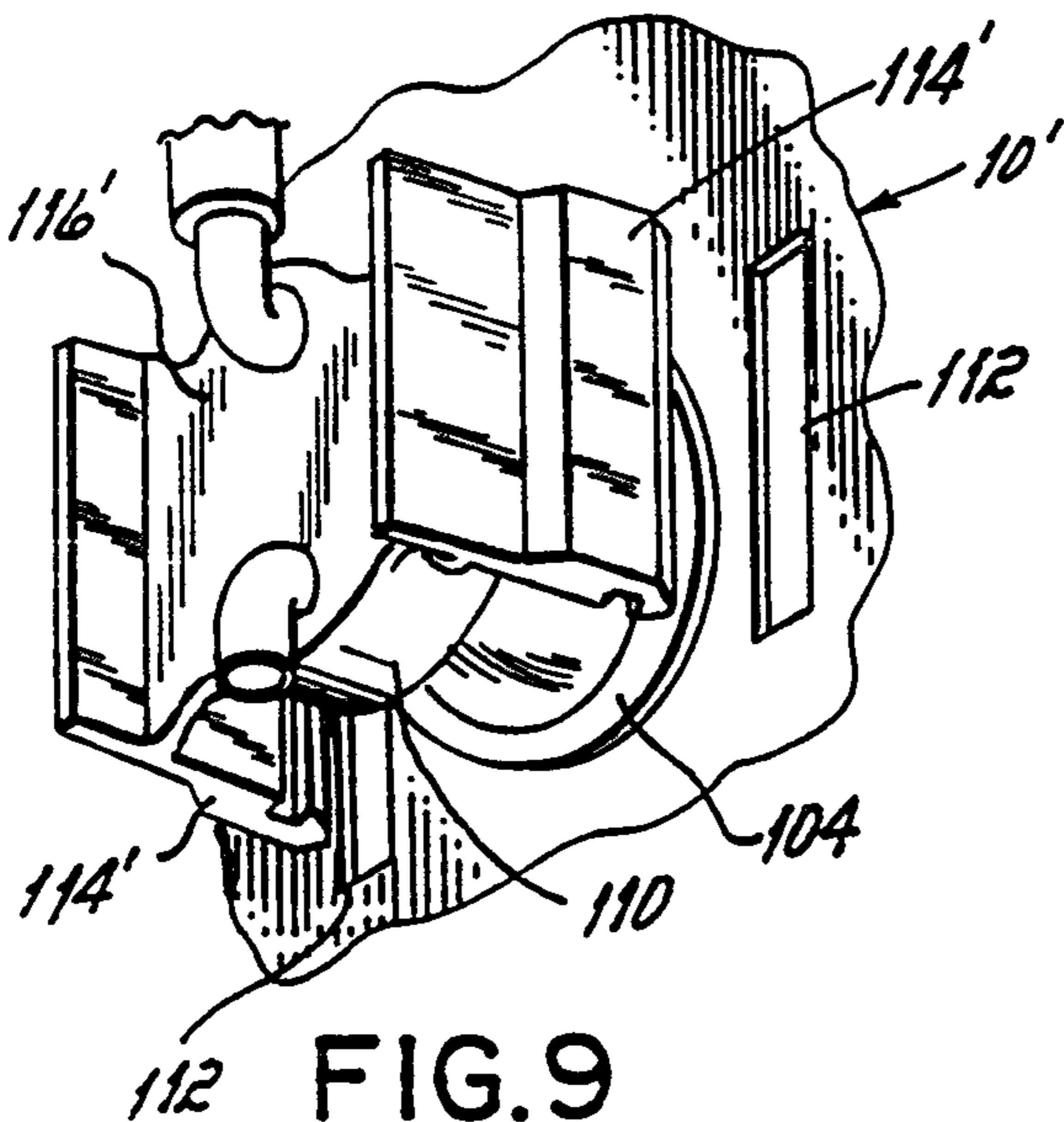

FIG. 9

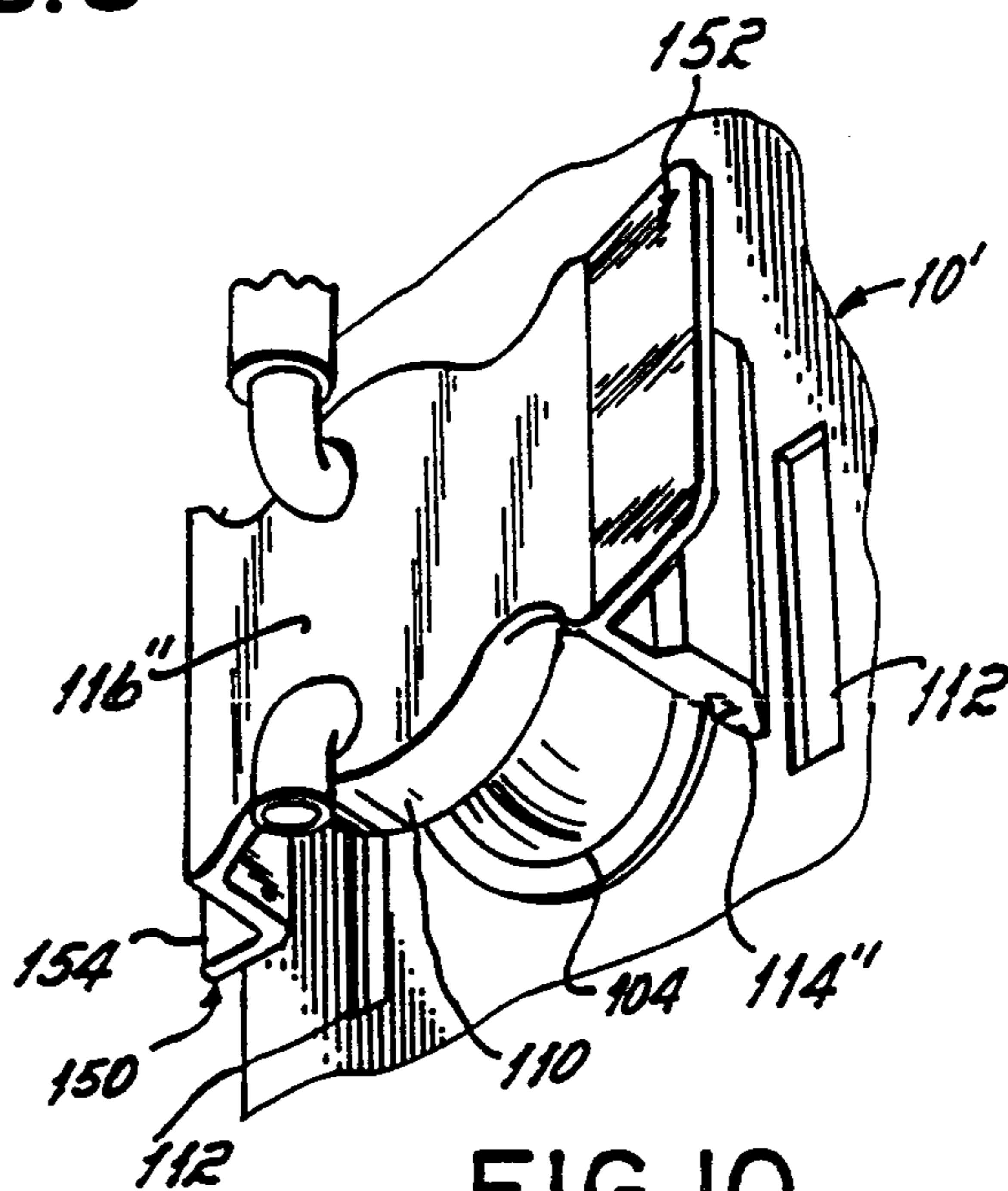

FIG. 10

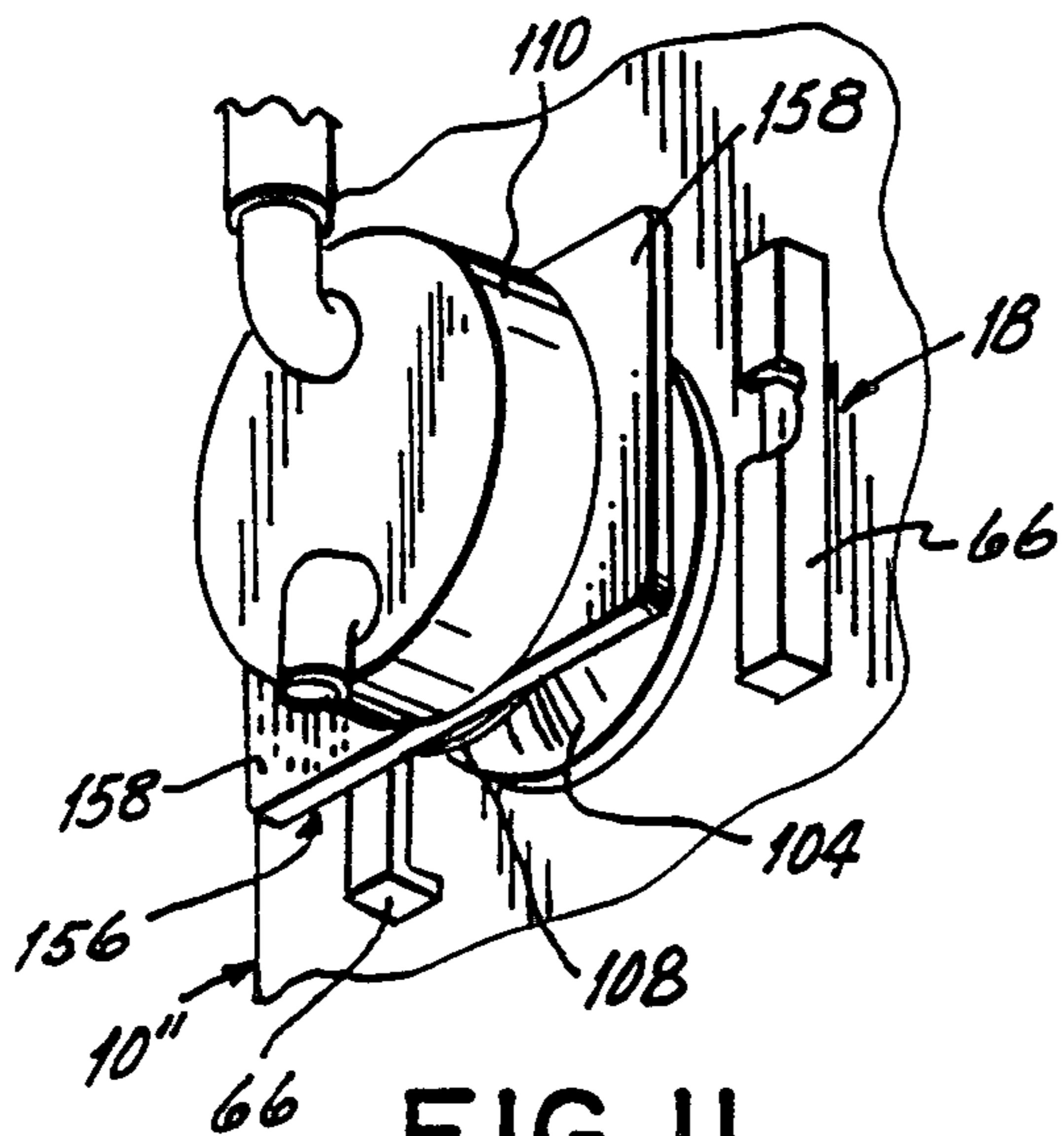

FIG. 11

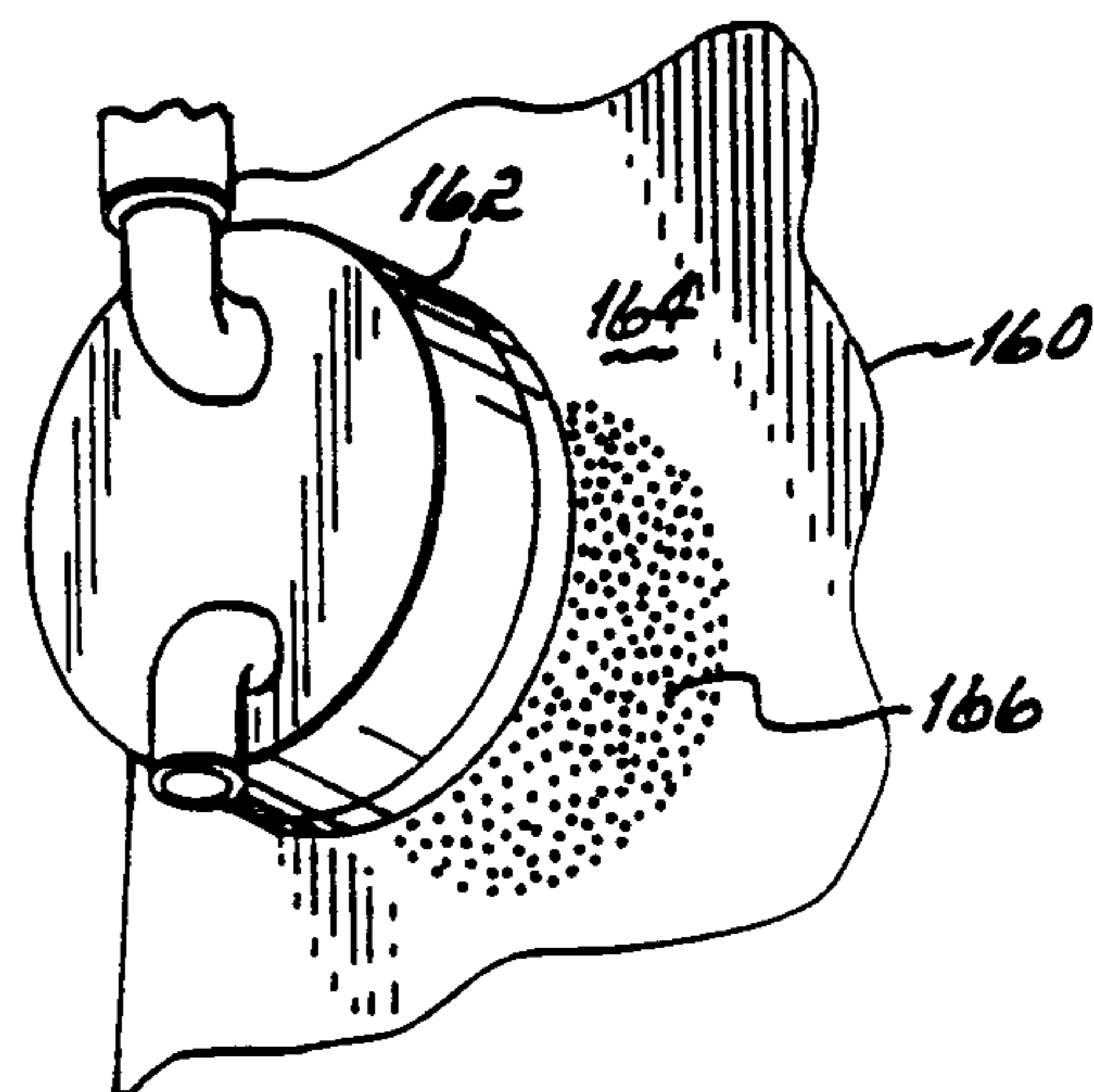

FIG. 12

