

(19) World Intellectual Property Organization  
International Bureau



(43) International Publication Date  
17 January 2008 (17.01.2008)

PCT

(10) International Publication Number  
**WO 2008/006778 A1**

- (51) International Patent Classification:  
G02C 5/22 (2006.01)
- (21) International Application Number:  
PCT/EP2007/056876
- (22) International Filing Date: 6 July 2007 (06.07.2007)
- (25) Filing Language: English
- (26) Publication Language: English
- (30) Priority Data:  
UD2006A000172 10 July 2006 (10.07.2006) IT
- (71) Applicant (for all designated States except US): **TARGET SRL** [IT/IT]; Località Zona Artigianale Industriale, 3, I-33020 Forni di Sotto (IT).
- (72) Inventor; and
- (75) Inventor/Applicant (for US only): **ANTONIACOMI, Renato** [IT/IT]; Via Nazionale, 106, I-33024 Forni di Sopra (IT).
- (74) Agents: **PETRAZ, Gilberto** et al.; Glp Srl, Piazzale Cavedalis, 6/2, I-33100 Udine (IT).

- (81) Designated States (unless otherwise indicated, for every kind of national protection available): AE, AG, AL, AM, AT, AU, AZ, BA, BB, BG, BH, BR, BW, BY, BZ, CA, CH, CN, CO, CR, CU, CZ, DE, DK, DM, DO, DZ, EC, EE, EG, ES, FI, GB, GD, GE, GH, GM, GT, HN, HR, HU, ID, IL, IN, IS, JP, KE, KG, KM, KN, KP, KR, KZ, LA, LC, LK, LR, LS, LT, LU, LY, MA, MD, ME, MG, MK, MN, MW, MX, MY, MZ, NA, NG, NI, NO, NZ, OM, PG, PH, PL, PT, RO, RS, RU, SC, SD, SE, SG, SK, SL, SM, SV, SY, TJ, TM, TN, TR, TT, TZ, UA, UG, US, UZ, VC, VN, ZA, ZM, ZW.
- (84) Designated States (unless otherwise indicated, for every kind of regional protection available): ARIPO (BW, GH, GM, KE, LS, MW, MZ, NA, SD, SL, SZ, TZ, UG, ZM, ZW), Eurasian (AM, AZ, BY, KG, KZ, MD, RU, TJ, TM), European (AT, BE, BG, CH, CY, CZ, DE, DK, EE, ES, FI, FR, GB, GR, HU, IE, IS, IT, LT, LU, LV, MC, MT, NL, PL, PT, RO, SE, SI, SK, TR), OAPI (BF, BJ, CF, CG, CI, CM, GA, GN, GQ, GW, ML, MR, NE, SN, TD, TG).

Published:  
— with international search report

For two-letter codes and other abbreviations, refer to the "Guidance Notes on Codes and Abbreviations" appearing at the beginning of each regular issue of the PCT Gazette.

(54) Title: FRAME FOR SPECTACLES

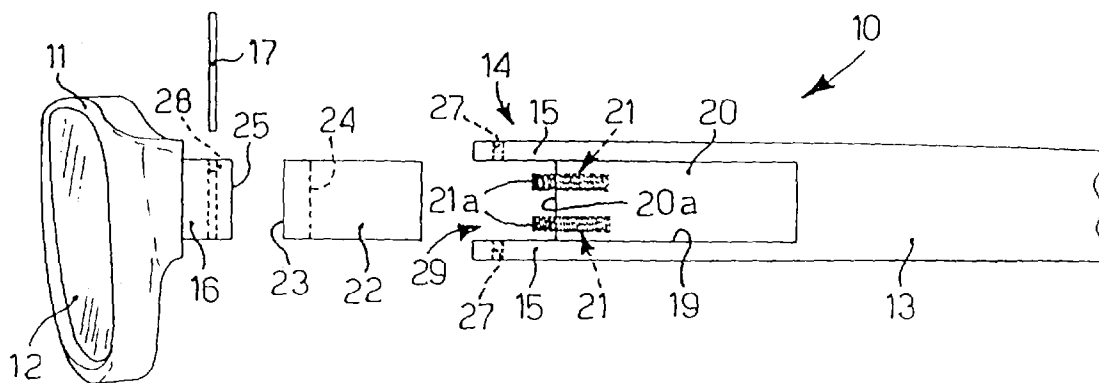

(57) Abstract: Frame for spectacles (10) comprising a front component (11) that supports a pair of lenses (12), two supporting temples (13) each hinged by means of respective hinging elements (15, 16, 17) to the front component (11), and cushioning and recall members associated with the hinging elements (15, 16, 17). The cushioning members comprise: elastic elements (21) disposed in an open seating made inside the bulk of the respective temple (13) and configured so that a part (21a) of the elastic elements (21) is facing towards the outside in the open seating, in the direction of the front component (11); and a cursor element (22) disposed as an extension and completely inside the bulk of the respective temple (13), so as to slide longitudinally along it at the moment of opening-closing of the relative temple (13) with respect to the front component (11), and comprising a second surface (23), or external surface, disposed in contact with the front component (11), and a first surface (24), or internal surface, opposite the second surface (23), on which the part (21a) of the elastic elements (21) facing towards the outside in the open seating acts, so as to keep the cursor element (22) normally thrusting against the front component (11).

WO 2008/006778 A1

- 1 -

## “FRAME FOR SPECTACLES”

\* \* \* \* \*

## FIELD OF THE INVENTION

The present invention concerns a frame for spectacles of the type with  
5 temples at least partly inclinable elastically towards the outside, beyond the  
normal position of use, with respect to a front supporting component for the  
lenses, so as to facilitate the operations to put on and take off the spectacles  
for the user.

A frame for spectacles having the features of the preamble of the main  
10 claim is disclosed in WO-A-96/37801 and in FR-A-2.485.212.0

## BACKGROUND OF THE INVENTION

Frames for spectacles are known, substantially consisting of two temples or  
side-pieces, hinged on opposite sides to a lateral part, in Italian also called the  
“snout”, of a front supporting component for the lenses, so as to be able to be  
15 rotated from a closed position substantially parallel to the “snout”, to an open  
position substantially perpendicular to the “snout”.

Frames for spectacles are also known, in which the temples are hinged to  
the front component in such a manner as to allow, apart from a rotation from  
the closed position to the open position, a partial inclination of the temples  
20 towards the outside with respect to the normal position of use, in order to  
facilitate the user in putting on and taking off the spectacles.

This type of frame is normally provided with elastic return means, provided  
for example with springs, rubber blocks, steel elements with a memory or  
others, defining an elastic hinge-type connection between the temples and the  
25 front component, so as to allow the temples to return automatically to their  
open position.

The elastic means normally used, however, is disposed in such a manner  
that it exerts torsion stresses on the mechanical components of the hinges,  
which cause an increase in wear of the components and, with time,  
30 deformations and/or breakages thereof.

In order to limit such deformations and breakages, it is known to make the  
hinges with materials highly resistant to said torsion stresses, or to design  
hinges with particular solutions, normally consisting of a large number of

- 2 -

components, such as springs, sliders, cams or other, which guarantee a longer duration of the hinge.

However, these solutions are particularly expensive and not always compatible with the design and lightness of the frame.

5 Moreover, in most of the known hinge/return means systems, there are in any case screws present, or other attachment elements, of very limited size which require specific tools and extremely precise assembly operations.

Elastic hinges are also known, provided with a cursor element able to slide with respect to the temple due to the effect of the thrust of the spring, and  
10 protruding outside the temple in order to define the limit positions of opening and closing of the temple with respect to the front component.

The parts of the cursor that protrude outside the lateral bulk of the temple are limitative, however, in terms of the possible aesthetic conformations of the temple, and are a complication with regard to the making of the cursor itself,  
15 both in terms of production and also in terms of functionality, also considering the size and tolerances required.

Furthermore, the solution with the cursor protruding outside the temple entails a thickening of the male/female pivots of the hinge in order to guarantee adequate abutment surfaces of the protruding portion and the correct  
20 pivoting of the parts, with a consequent increase in production costs, and also the possibility of knocking against the temples of the user when the spectacles are worn.

One purpose of the present invention is therefore to achieve a frame for spectacles of the type with temples at least partly inclinable elastically towards  
25 the outside beyond the normal position of use, where the hinges have a prolonged resistance over time, limiting the risk of deformation and breakages of the mechanical components and without needing to use materials that are highly resistant to torsion or stresses or particular design solutions.

Another purpose of the present invention is to achieve a frame for  
30 spectacles which solves said disadvantages of the state of the art, simply and economically, using components that are easy to assemble and that need little or no maintenance and are not subject to wear.

The Applicant has devised, tested and embodied the present invention to

- 3 -

overcome the shortcomings of the state of the art and to obtain these and other purposes and advantages.

#### SUMMARY OF THE INVENTION

5 The present invention is set forth and characterized in the independent claim, while the dependent claims describe other characteristics of the invention or variants to the main inventive idea.

10 In accordance with the above purposes, a frame for spectacles according to the present invention comprises a front component, or "snout", which supports a pair of lenses, two supporting temples each hinged by means of respective hinging means to the front component, and elastic cushioning and recall means associated with the hinging means, which allow an inclination of the temples towards the outside, beyond the normal positions of use, with automatic return to the open position of the temple with respect to the front component.

15 The cushioning and recall means comprises elastic means disposed in an open seating made inside the bulk of the respective temple and configured so that a part of said elastic means faces towards the outside in said open seating, in the direction of said "snout".

20 The cushioning and recall means also comprises a cursor element disposed completely inside the bulk and as an extension of the relative temple.

25 The cursor element is able to slide longitudinally along the temple at the moment the latter is opened or closed with respect to the front part. The cursor element comprises a second surface, or external surface going from the "snout" towards the temple, disposed in contact with the front component, and a first surface, or internal surface going from the "snout" towards the temple, on which the part of the elastic means facing towards the outside in the open seating acts, in order to maintain the cursor element normally thrusting against the front component.

30 In this way, in the event of a partial rotation of the temple towards the outside, beyond the normal position of use, the cursor element slides longitudinally, completely comprised inside the bulk of the temple, compressing the elastic means which, when the stress imparted to the temple is terminated, causes the automatic return of the temple to its open position of

- 4 -

use, that is, a condition in which the second surface of the cursor element is completely in contact with the front component.

With the present invention, the thrust exerted by the elastic means on the cursor element is such as not to compromise the correct and long-lasting  
5 functioning of the hinging means, since this thrust has a single direction always substantially longitudinal, and takes place completely inside the bulk of the temple, and hence it does not generate significant moments of torsion on the components of the hinging means.

This advantage allows to use simplified hinging means made with materials  
10 having a limited cost.

Moreover, the position of the cursor element, completely comprised inside the bulk of the temple, prevents any type of protrusion of the latter to the outside, thus improving the simplicity of production of the parts, the longitudinal nature of the shapes and the good possibility of aesthetically  
15 personalizing the frame thus made.

According to a preferential form of embodiment, the elastic means consists of two springs disposed symmetrically astride the longitudinal median plane of the temple, and with a segment protruding into said open seating, to cooperate with said first surface of the cursor. In this way, the effort to which  
20 the springs are subjected is shared in a balanced way, further reducing the tensions and stresses to which the elastic means is subjected.

According to a preferential form of embodiment, the hinging means is defined by a simple, male/female coupling of shape between the temple and the front component and by a single pin disposed through between the two. In  
25 this embodiment, considering the normal stresses to which they are subjected, the components of the hinging means are made for example of plastic, wood, common steels or other material of limited cost.

This solution thus allows to considerably reduce both the number of components and the overall costs of producing the frame for spectacles.

30 In another form of embodiment of the present invention, the distance between the axis of rotation of the pin of the hinging means and the segment of the front component that contacts the cursor element in the condition when the temple is rotated towards the outside, beyond the position of use, is greater

- 5 -

than the possible travel of the cursor element along the temple.

This geometric positioning condition of the pin prevents the cursor element from overlapping said segment of the front component, thus causing the temple to stop rotating after some degrees with respect to the position of use.

5 BRIEF DESCRIPTION OF THE DRAWINGS

These and other characteristics of the present invention will become apparent from the following description of a preferential form of embodiment, given as a non-restrictive example with reference to the attached drawings wherein:

- 10 - fig. 1 is an exploded, lateral and part view of a frame for spectacles according to the present invention;  
- fig. 2 is a view from above of an assembled detail of the frame in fig. 1 in a first operating condition;  
- fig. 3 is a view from above of the detail in fig. 2 in a second operating  
15 condition.

DETAILED DESCRIPTION OF A PREFERENTIAL FORM OF  
EMBODIMENT

With reference to the attached figures, a frame for spectacles 10 according to the present invention comprises a front component 11 that supports two  
20 lenses 12, for example sun lenses, sight lenses, protective lenses or suchlike, and two supporting temples 13, or side-pieces, of which only one is visible in the figures. Both the temples 13 and the front component 11 can be made of plastic material, wood or other suitable material.

The temples 13 are hinged on opposite sides, by means of respective fork-shaped ends 14, to the lateral part of the front component 11, in Italian also  
25 called the "snout".

The fork-shaped end 14 is defined by two fins 15, substantially parallel and of the same length, and by an empty space 29 between them (fig. 1), said space 29 being open towards the "snout" 11.

30 The fins 15 of the fork-shaped end 14 are coupled with play to a mating hinging block 16 provided on the front component 11. A metal pin 17 is disposed through respective holes 27 and 28 made in the two fins 15 and on the block 16, to determine the hinging of the temples 13 and the front

- 6 -

component 11.

On the two lateral flanks of said fork-shaped end 14, in a position substantially comprised between the two hinging fins 15, and in an internal position with respect to the empty space 29, two sliding seatings 19 are also  
5 made longitudinally.

The two sliding seatings 19 define between them a central wall 20, of a lesser thickness than the temple 13, between the two hinging fins 15.

In the central wall 20 two helical springs 21 are also housed, disposed in a direction substantially longitudinal to the temple 13, astride the longitudinal  
10 median plane of the temple 13, and having an end segment 21a that protrudes into the empty space 29 from a front surface 20a of the central wall 20, in any case in an area comprised inside the bulk of the respective temple 13.

The frame 10 also comprises a cursor element 22 made for example of plastic material and substantially C-shaped, which is disposed astride the  
15 central wall 20, so as to be partly housed in the sliding seatings 19, and in any case completely comprised inside the lateral bulk of the temple 13.

The cursor element 22 comprises at least a first thrust surface 24, internal, with reference to the relative temple 13, on which the external segment 21a of the helical springs 21, facing into the empty space 29, acts.

In this way, the cursor element 22 can slide longitudinally to the temple 13,  
20 in a guided manner and with a slight play, inside the sliding seatings 19, for a determinate travel "T", defined by the maximum compression of the helical springs 21.

The cursor element 22 also comprises a second head surface 23, opposite  
25 the thrust surface 24, which due to the effect of the thrust exerted by the helical springs 21 (fig. 2) on the first thrust surface 24, contacts with a slight pressure a corresponding abutment surface 25 of the hinging block 16, maintaining the temple 13 stably in the open position of use of the frame 10.

On the contrary, by rotating the temple 13 towards the outside, beyond the  
30 position of use, the second head surface 23 of the cursor element 22 slides on an external edge 26 of the abutment surface 25, and the cursor element 22, overcoming the thrust of the helical springs 21, is longitudinally displaced with respect to the temple 13 along the sliding seatings 19 until it reaches a

- 7 -

condition of maximum compression of the helical springs 21, that is, its maximum possible travel T.

According to an embodiment of the present invention, the distance "D" between the axis of rotation of the metal pin 17 and the external edge 26 of the hinging block 16 is greater than the travel T of the cursor element 22.

This geometric positioning condition of the metal pin 17 prevents the second head surface 23 from overlapping the external edge 26 of the hinging block 16, thus stopping the rotation of the temple 13 after some degrees (fig. 3), for example after about 20°, beyond the open position of use.

10 It is clear, however, that modifications and/or additions of parts may be made to the frame for spectacles 10 as described heretofore, without departing from the scope of the present invention.

For example, it comes within the scope of the present invention to provide that the cursor element 22 is provided, at least on one surface facing towards the outside of the frame 10, with trade marks, logos, writings, or alphanumerical symbols, which identify for example the producer or the distributor of the frame for spectacles 10.

According to another variant, the elastic means comprises only one helical spring 21, to allow a reduction in width of the temple 13.

20 It is also possible to use leaf springs, cup springs or springs of another type, instead of the helical springs 21 already described.

It also comes within the scope of the present invention to provide that the cursor element is made of a wood material or wood substitute.

25 It is also clear that, although the present invention has been described with reference to specific examples, a person of skill in the art shall certainly be able to achieve many other equivalent forms of frame for spectacles, having the characteristics as set forth in the claims and hence all coming within the scope of protection defined thereby.

- 8 -

## CLAIMS

1. Frame for spectacles comprising a front component (11) able to support a pair of lenses (12), two supporting temples (13) each hinged by means of respective hinging means (15, 16, 17) to said front component (11), and  
5 cushioning and recall means associated with said hinging means (15, 16, 17), characterized in that said cushioning means comprises:
- elastic means (21) disposed in an open seating made inside the bulk of the respective temple (13) and configured so that a part (21a) of said elastic means (21) is facing towards the outside in said open seating, in the  
10 direction of said front component (11); and
  - a cursor element (22) disposed as an extension and completely inside the bulk of the respective temple (13), so as to slide longitudinally along it at the moment of opening-closing of the relative temple (13) with respect to said front component (11), and comprising at least a second surface (23), or  
15 external surface, disposed in contact with said front component (11), and a first surface (24), or internal surface, opposite said second surface (23), on which said part (21a) of said elastic means (21) facing towards the outside in said open seating is able to act, so as to keep said cursor element (22) normally thrusting against said front component (11).
- 20 2. Frame for spectacles as in claim 1, characterized in that each of said temples (13) comprises a fork-shaped end (14) with two fins (15) defining an empty space (29) between them that forms said open seating and facing towards said front component (11).
3. Frame as in claim 2, characterized in that, on said end (14), two sliding  
25 seatings (19) are made longitudinally on opposite sides for said cursor element (22), said sliding seatings (19) defining between them a central wall (20) with a reduced thickness with respect to the temple (13).
4. Frame for spectacles as in claim 3, characterized in that said elastic means (21) is housed in said central wall (20) and partly protrudes into said empty  
30 space (29) from a front surface (20a) of said central wall (20), to contact said first surface (24) of said cursor element (22).
5. Frame for spectacles as in any claim hereinbefore, characterized in that said elastic means comprises at least a helical spring (21), able to act in a direction

- 9 -

substantially longitudinal to the relative temple (13).

6. Frame for spectacles as in any claim hereinbefore, characterized in that said elastic means comprises two springs disposed symmetrically astride the longitudinal median plane of said temples (13).

5 7. Frame for spectacles as in claim 3, characterized in that said cursor element (22) is substantially C-shaped, and is disposed astride said relative temple (13), and is able to cooperate with the inside of said sliding seatings (19) in order to slide longitudinally to the temple (13), in a guided manner and with a slight play, for a determinate travel (T).

10 8. Frame for spectacles as in claim 2, characterized in that said hinging means comprises a hinging block (16), made on said front component (11) and disposed with play between said fins (15), and a pin (17) disposed both through said fins (15) and also through said hinging block (16).

9. Frame for spectacles as in claim 8, characterized in that said hinging block  
15 (16) comprises an abutment surface (25) facing towards the respective temple (13) and on which said second surface (23) of said cursor element (22) rests.

10. Frame for spectacles as in claim 9, characterized in that at the moment when said temple (13) opens towards the outside, said head surface (23) of said cursor element (22) slides on an external edge (26) of said abutment  
20 surface (25) of said hinging block (16).

11. Frame for spectacles as in claim 10, characterized in that the distance (D) between the axis of rotation of said pin (17) and said external edge (26) of said abutment surface (25) is greater than the travel (T) of said cursor element (22) in said sliding seatings (19).

25 12. Frame for spectacles as in any claim hereinbefore, characterized in that both said temples (13) and also said front component (11) and said cursor element (22) are made of plastic material.

13. Frame for spectacles as in any claim hereinbefore, characterized in that at least said cursor element (22) is made of wood material or wood substitute  
30 materials.

14. Frame for spectacles as in any claim hereinbefore, characterized in that on at least an external surface of said cursor element (22) a graphic or alphanumeric symbol is provided identifying said frame for spectacles (10).

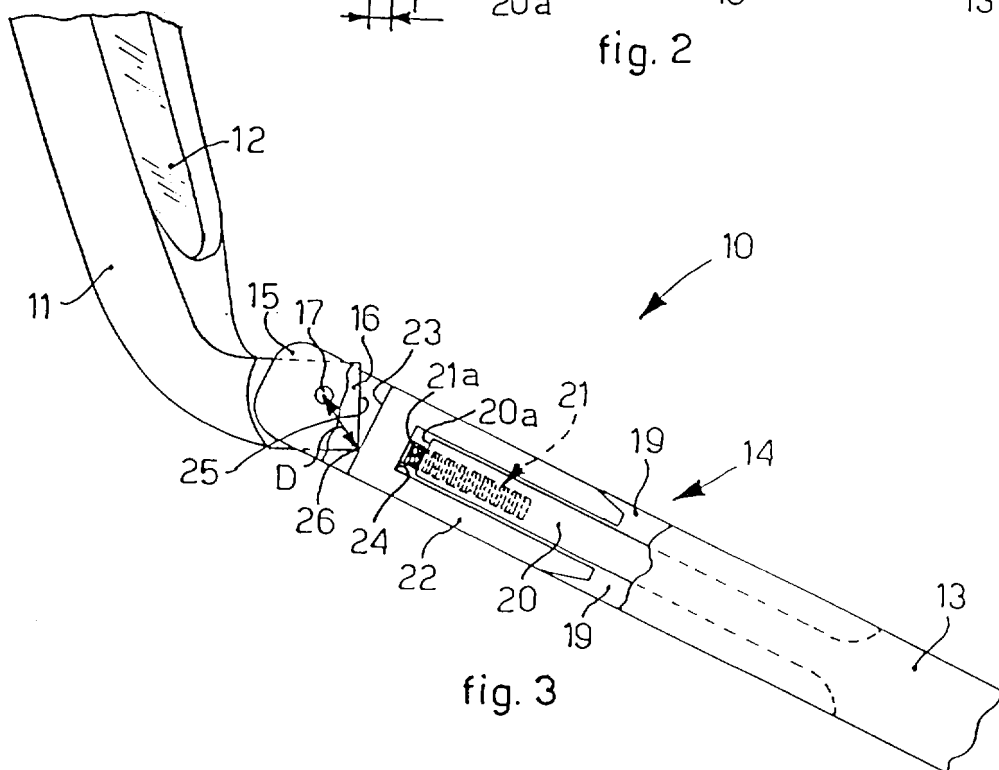
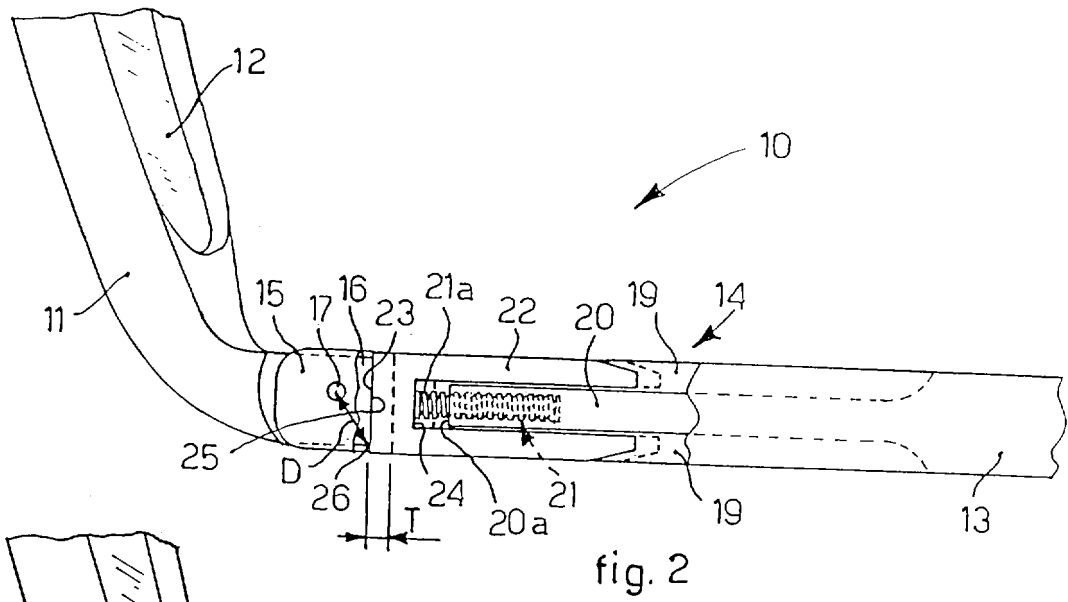
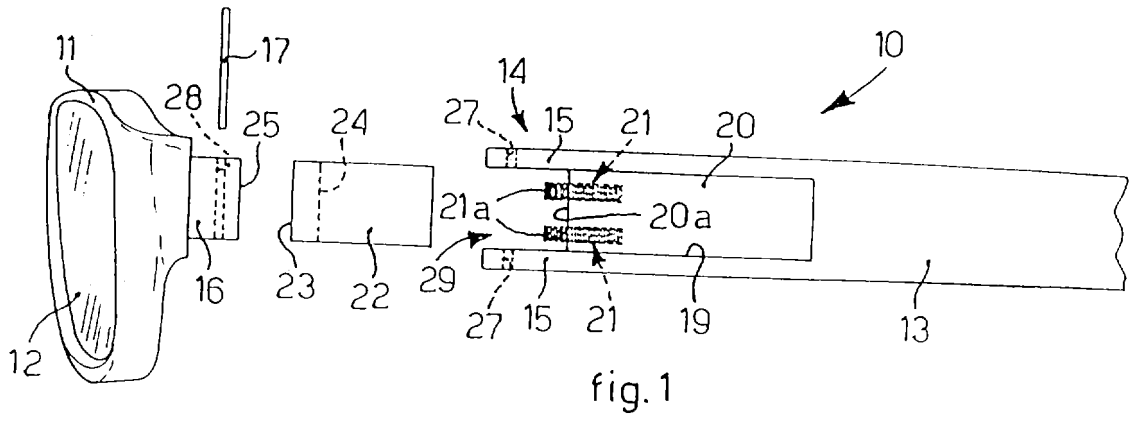

## INTERNATIONAL SEARCH REPORT

International application No

PCT/EP2007/056876

A. CLASSIFICATION OF SUBJECT MATTER  
INV. G02C5/22

According to International Patent Classification (IPC) or to both national classification and IPC

## B. FIELDS SEARCHED

Minimum documentation searched (classification system followed by classification symbols)  
G02C

Documentation searched other than minimum documentation to the extent that such documents are included in the fields searched

Electronic data base consulted during the international search (name of data base and, where practical, search terms used)

EPO-Internal

## C. DOCUMENTS CONSIDERED TO BE RELEVANT

Category*	Citation of document, with indication, where appropriate, of the relevant passages	Relevant to claim No.
X	US 2005/225716 A1 (KCAVENDA CVIJETA [BA]) 13 October 2005 (2005-10-13) pages 1,2, paragraph 22-34	1-14
X	WO 96/37801 A (MARCOLIN S P A [IT]; DA FORNO ALESSANDRO [IT]) 28 November 1996 (1996-11-28) claims	1
X	WO 2005/008317 A (MILAN DI KCAVENDA MILENKO [IT]; KCAVENDA MILAN [IT]) 27 January 2005 (2005-01-27) claims	1
A	FR 2 398 322 A1 (JEUNET JEAN PIERRE [FR] JEUNET JEAN PIERRE) 16 February 1979 (1979-02-16) page 2, line 33 - page 3, line 36	1-14

Further documents are listed in the continuation of Box C.

See patent family annex.

\* Special categories of cited documents :

- \*A\* document defining the general state of the art which is not considered to be of particular relevance
- \*E\* earlier document but published on or after the international filing date
- \*L\* document which may throw doubts on priority claim(s) or which is cited to establish the publication date of another citation or other special reason (as specified)
- \*O\* document referring to an oral disclosure, use, exhibition or other means
- \*P\* document published prior to the international filing date but later than the priority date claimed

\*T\* later document published after the international filing date or priority date and not in conflict with the application but cited to understand the principle or theory underlying the invention

\*X\* document of particular relevance; the claimed invention cannot be considered novel or cannot be considered to involve an inventive step when the document is taken alone

\*Y\* document of particular relevance; the claimed invention cannot be considered to involve an inventive step when the document is combined with one or more other such documents, such combination being obvious to a person skilled in the art.

\*Z\* document member of the same patent family

Date of the actual completion of the international search

18 September 2007

Date of mailing of the international search report

28/09/2007

Name and mailing address of the ISA/

European Patent Office, P.B. 5818 Patentlaan 2  
NL - 2280 HV Rijswijk  
Tel. (+31-70) 340-2040, Tx. 31 651 epo nl,  
Fax: (+31-70) 340-3016

Authorized officer

Cantalapiedra, Igor

## INTERNATIONAL SEARCH REPORT

International application No  
PCT/EP2007/056876

C(Continuation). DOCUMENTS CONSIDERED TO BE RELEVANT		
Category*	Citation of document, with indication, where appropriate, of the relevant passages	Relevant to claim No.
A	FR 2 485 212 A3 (SAFILO SPA [IT]) 24 December 1981 (1981-12-24) claims -----	1-14
A	US 6 231 181 B1 (SWAB GREGG T [US]) 15 May 2001 (2001-05-15) column 4, lines 21-42 -----	1-14
A	FR 2 521 310 A3 (CASTELLANI DANILO [IT]) 12 August 1983 (1983-08-12) page 2, line 21 - page 3 -----	1-14
A	FR 1 511 263 A (SAFILO S P A FABBRICA ITALIANA) 8 April 1968 (1968-04-08) page 1, right-hand column, line 20 - page 2, right-hand column, line 2 -----	1-14

## INTERNATIONAL SEARCH REPORT

Information on patent family members

International application No

PCT/EP2007/056876

Patent document cited in search report	Publication date	Patent family member(s)	Publication date
US 2005225716	A1	13-10-2005	NONE
WO 9637801	A	28-11-1996	EP 0829030 A1 18-03-1998 IT BL950007 A1 25-11-1996 JP 11505934 T 25-05-1999 US 5953791 A 21-09-1999
WO 2005008317	A	27-01-2005	AU 2004257932 A1 27-01-2005 BR PI0412863 A 03-10-2006 CA 2533015 A1 27-01-2005 CN 1839335 A 27-09-2006 EP 1646906 A1 19-04-2006 JP 2006528370 T 14-12-2006 KR 20060061800 A 08-06-2006 US 2006209251 A1 21-09-2006
FR 2398322	A1	16-02-1979	NONE
FR 2485212	A3	24-12-1981	CH 646529 A5 30-11-1984 DE 8117403 U1 03-12-1981 JP 57011509 U 21-01-1982 JP 61036973 Y2 27-10-1986
US 6231181	B1	15-05-2001	AU 5172801 A 03-10-2001 CA 2403638 A1 27-09-2001 CN 1449506 A 15-10-2003 CN 1821832 A 23-08-2006 EP 1266258 A2 18-12-2002 HK 1058240 A1 16-03-2007 JP 2003536093 T 02-12-2003 WO 0171413 A2 27-09-2001
FR 2521310	A3	12-08-1983	NONE
FR 1511263	A	08-04-1968	NONE