

C. H. SAYBOLT.
Refrigerator.

No. 229,277.

Patented June 29, 1880.

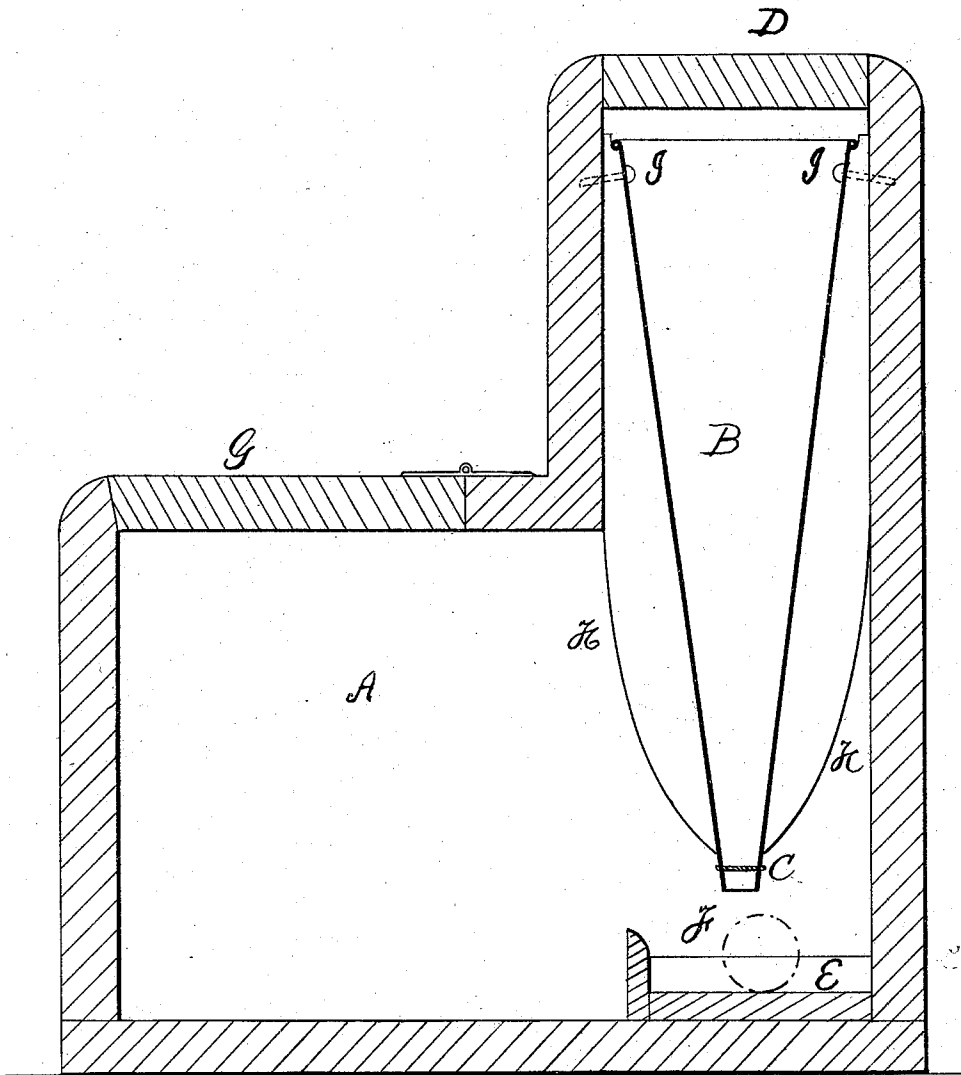

WITNESSES: _____

W. C. Brookes

W. Jay

INVENTOR: _____

Chas H. Saybolt.

UNITED STATES PATENT OFFICE.

CHARLES H. SAYBOLT, OF NEW YORK, N. Y.

REFRIGERATOR.

SPECIFICATION forming part of Letters Patent No. 229,277, dated June 29, 1880.

Application filed July 30, 1878.

To all whom it may concern:

Be it known that I, CHARLES H. SAYBOLT, of the city, county, and State of New York, have invented a new and useful Improvement in Refrigerators; and I do hereby declare that the following is a full, clear, and exact description of the same, reference being had to the drawing which accompanies and makes part of this specification, and which represents a sectional view of the apparatus employed.

My invention is applicable for refrigerators for family use, but is especially desirable for large refrigerating chambers or rooms for hotels and provision packers and dealers.

It consists in the employment of a number of wedge-shaped ice-holding tanks at one side of a refrigerator-casing which is so constructed that that part of the chamber in which the tanks are placed is higher than the main body of the casing, which forms the provision-chamber.

I construct the body of the refrigerating-chamber A of wood, and it may be provided with an air-space or a space filled with any suitable non-conducting material, in the usual way that refrigerator-casings are ordinarily made. On one side of the chamber, which is, as shown in the drawing, from one-fourth to one-third higher than the main body of the chamber, I place two or more tanks, B. These tanks are made preferably of heavy galvanized iron in the wedge shape shown in the drawing. They are to have a capacity proportioned to the size of the refrigerating-chamber, and are open at the top and bottom, the bottom of the tank being provided with a grating, C, for the purpose of retaining the ice. These tanks extend to within a few inches of the top and bottom of the chamber. At the top, directly over the opening of the tanks, a door, D, is placed for convenience of filling the tanks with ice.

A trough, E, is placed under the tanks, on the floor of the refrigerator, communicating with the outlet-pipe F, for the purpose of taking off the water resulting from the melting of the ice.

G is a door or doors opening into the main body of the refrigerator. These doors may be placed at the front or ends if desirable.

The tanks for holding the ice have supports or braces on each side, H, placed at suitable

intervals apart, and are suspended from hooks I at the top of the chamber.

The wedge-shape form given to the tanks for holding the ice is for the purpose of preventing any packing of the fragments of ice as it melts and settles down, these tanks being filled with ice broken into fragments of a suitable size.

The form of the refrigerator is an essential feature of the invention. By having the ice-holding portion of the chamber relatively higher than the main body of the chamber I obtain a better circulation of the air in the main body of the chamber rises to the highest point over the top of the ice-tanks, and passes downward through the interstices of the ice-fragments and around the outside of the ice-tanks, being cooled in its passage before passing out to the main body of the refrigerator.

The current of air circulates with great rapidity, and, as has been demonstrated by practical tests, the circulation is very much stronger and more rapid in a refrigerator constructed in the form shown than in a square or rectangular casing.

No external openings for ventilation are used, as the air in its passage through the interstices of the melting ice is cleansed of all its impurities, which are taken up and carried off by the water.

I claim as my invention—

In combination with an upward extension of the provision-chamber of a refrigerator, and freely suspended in the chamber, the wedge-shaped ice-receptacle B, open at the top and at the bottom—that is, at the small end of the wedge, near the bottom of the refrigerator—and arranged with the small end down, whereby warm air which has passed from the provision-chamber up into the extension will enter the top of the ice-receptacle from all sides and come in contact with the greatest extent of cooling-surface at first, the cooled air being finally discharged into the provision-chamber below from the bottom of the ice-receptacle, all as set forth.

CHS. H. SAYBOLT.

Witnesses:

J. A. BASSETT,
R. C. BEAMISH.