



(12) **DEMANDE DE BREVET CANADIEN
CANADIAN PATENT APPLICATION**

(13) **A1**

(86) Date de dépôt PCT/PCT Filing Date: 2017/04/25
 (87) Date publication PCT/PCT Publication Date: 2017/11/02
 (85) Entrée phase nationale/National Entry: 2018/10/25
 (86) N° demande PCT/PCT Application No.: GB 2017/051139
 (87) N° publication PCT/PCT Publication No.: 2017/187148
 (30) Priorité/Priority: 2016/04/27 (GB1607322.3)

(51) Cl.Int./Int.Cl. *A24F 47/00* (2006.01),
A61M 11/04 (2006.01), *A61M 15/06* (2006.01),
A61M 16/00 (2006.01)
 (71) Demandeur/Applicant:
NICOVENTURES HOLDINGS LIMITED, GB
 (72) Inventeur/Inventor:
FRASER, RORY, GB
 (74) Agent: BERESKIN & PARR LLP/S.E.N.C.R.L.,S.R.L.

(54) Titre : SYSTEME DE FOURNITURE D'AEROSOL ELECTRONIQUE ET VAPORISATEUR ASSOCIE
 (54) Title: ELECTRONIC AEROSOL PROVISION SYSTEM AND VAPORIZER THEREFOR

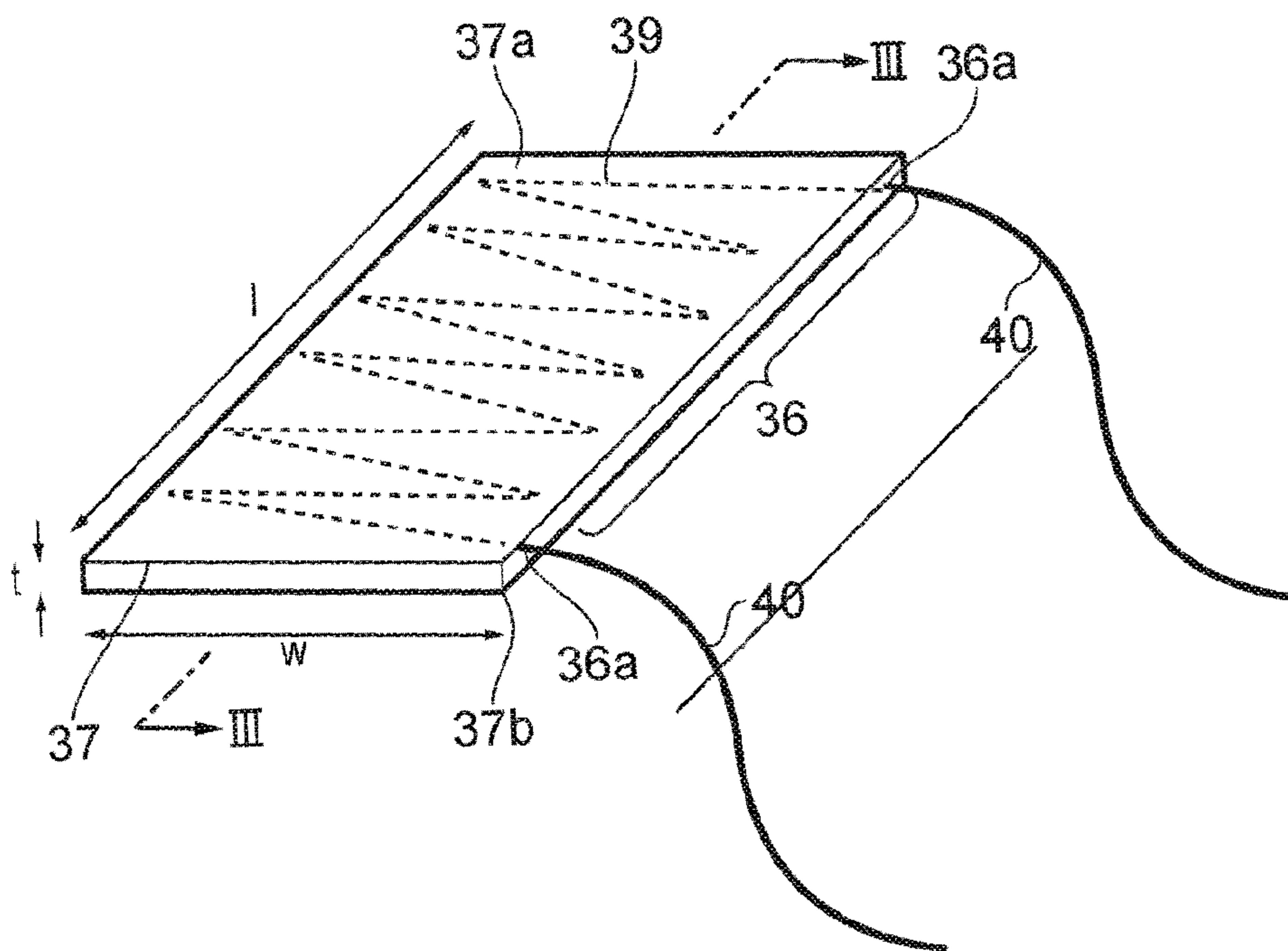

FIG. 2

(57) **Abrégé/Abstract:**

A sub-assembly for an electronic vapour provision system comprises: a source of liquid for vaporisation; and a vaporizer for vaporising a portion of the liquid for inhalation by a user, the vaporizer comprising: a wick component; and an electrical heating element embedded in the wick component; wherein the wick component comprises a sheet of a porous electrically-insulating material and is arranged to wick liquid from the source of liquid to a surface of the wick component adjacent to the embedded electrical heating element for vaporisation.

(12) INTERNATIONAL APPLICATION PUBLISHED UNDER THE PATENT COOPERATION TREATY (PCT)

(19) World Intellectual Property
Organization
International Bureau(10) International Publication Number
WO 2017/187148 A1(43) International Publication Date
02 November 2017 (02.11.2017)

(51) International Patent Classification:

A24F 47/00 (2006.01) A61M 11/04 (2006.01)
A61M 15/06 (2006.01) A61M 16/00 (2006.01)

(21) International Application Number:

PCT/GB2017/051139

(22) International Filing Date:

25 April 2017 (25.04.2017)

(25) Filing Language:

English

(26) Publication Language:

English

(30) Priority Data:

1607322.3 27 April 2016 (27.04.2016) GB

(71) Applicant: NICOVENTURES HOLDINGS LIMITED
[GB/GB]; Globe House, 1 Water Street, London WC2R
3LA (GB).(72) Inventor: FRASER, Rory; c/o Nicoventures Holdings
Limited, Globe House, 1 Water Street, London WC2R 3LA
(GB).(74) Agent: MCGOWAN, Cathrine; D Young & Co LLP, 120
Holborn, London EC1N 2DY (GB).(81) Designated States (unless otherwise indicated, for every
kind of national protection available): AE, AG, AL, AM,
AO, AT, AU, AZ, BA, BB, BG, BH, BN, BR, BW, BY, BZ,
CA, CH, CL, CN, CO, CR, CU, CZ, DE, DJ, DK, DM, DO,
DZ, EC, EE, EG, ES, FI, GB, GD, GE, GH, GM, GT, HN,
HR, HU, ID, IL, IN, IR, IS, JP, KE, KG, KH, KN, KP, KR,
KW, KZ, LA, LC, LK, LR, LS, LU, LY, MA, MD, ME, MG,
MK, MN, MW, MX, MY, MZ, NA, NG, NI, NO, NZ, OM,
PA, PE, PG, PH, PL, PT, QA, RO, RS, RU, RW, SA, SC,
SD, SE, SG, SK, SL, SM, ST, SV, SY, TH, TJ, TM, TN, TR,
TT, TZ, UA, UG, US, UZ, VC, VN, ZA, ZM, ZW.(84) Designated States (unless otherwise indicated, for every
kind of regional protection available): ARIPO (BW, GH,
GM, KE, LR, LS, MW, MZ, NA, RW, SD, SL, ST, SZ, TZ,
UG, ZM, ZW), Eurasian (AM, AZ, BY, KG, KZ, RU, TJ,
TM), European (AL, AT, BE, BG, CH, CY, CZ, DE, DK,
EE, ES, FI, FR, GB, GR, HR, HU, IE, IS, IT, LT, LU, LV,
MC, MK, MT, NL, NO, PL, PT, RO, RS, SE, SI, SK, SM,
TR), OAPI (BF, BJ, CF, CG, CI, CM, GA, GN, GQ, GW,
KM, ML, MR, NE, SN, TD, TG).

(54) Title: ELECTRONIC AEROSOL PROVISION SYSTEM AND VAPORIZER THEREFOR

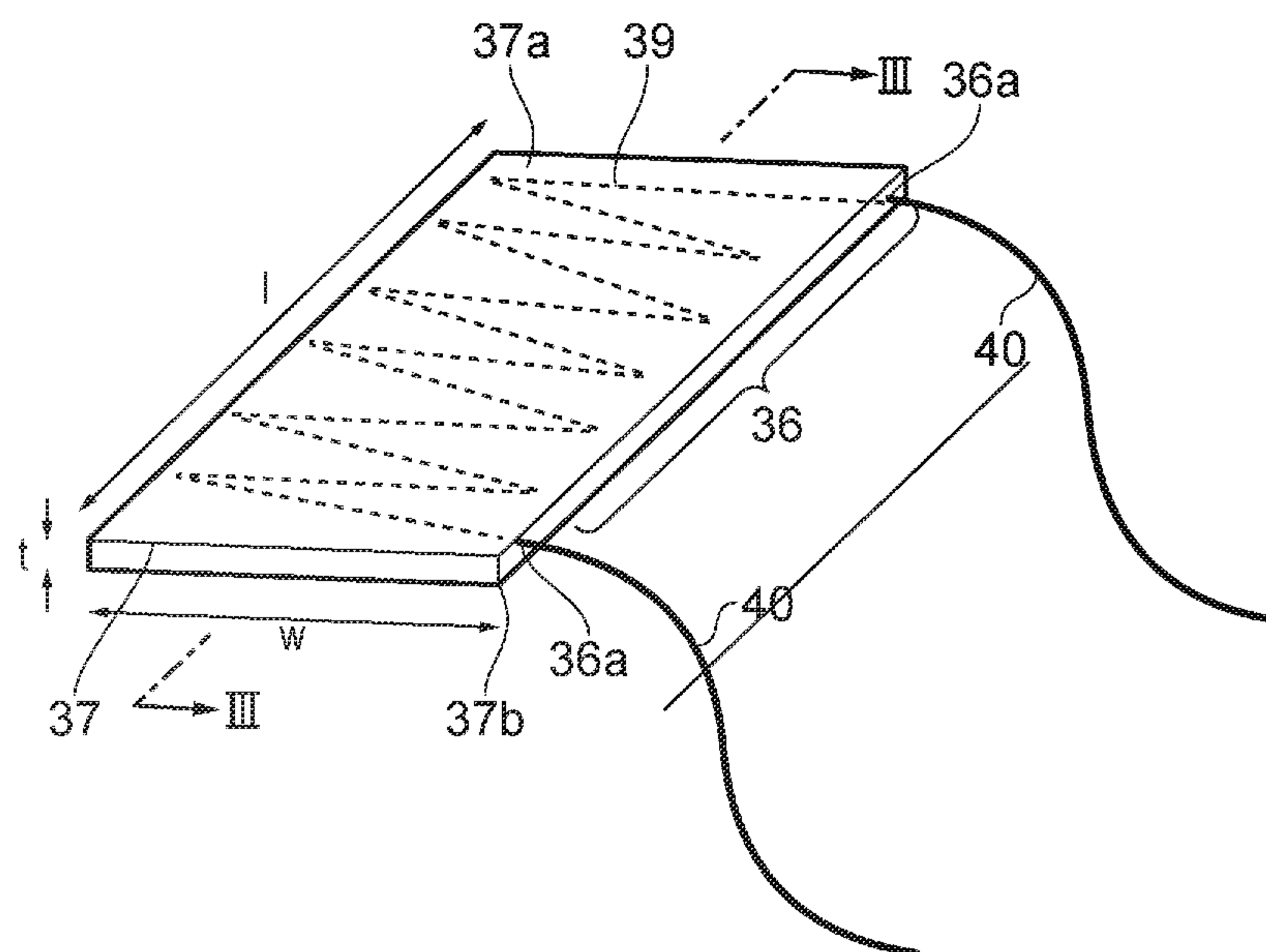

FIG. 2

(57) Abstract: A sub-assembly for an electronic vapour provision system comprises: a source of liquid for vaporisation; and a vaporizer for vaporising a portion of the liquid for inhalation by a user, the vaporizer comprising: a wick component; and an electrical heating element embedded in the wick component; wherein the wick component comprises a sheet of a porous electrically-insulating material and is arranged to wick liquid from the source of liquid to a surface of the wick component adjacent to the embedded electrical heating element for vaporisation.

[Continued on next page]

WO 2017/187148 A1 

Published:

— *with international search report (Art. 21(3))*

P108644GB: BAT P13115314

ELECTRONIC AEROSOL PROVISION SYSTEM AND VAPORIZER THEREFOR**Technical Field**

The present invention relates to aerosol provision systems and vaporizers for use in aerosol provision systems.

5 **Background**

Vapour or aerosol provision systems and devices, such as electronic cigarettes, typically include a reservoir of a source liquid, perhaps including nicotine, and a heater or heating element powered by a battery which acts to vaporize the source liquid for inhalation by a user. A wick may be used to deliver source liquid to the heating element
10 for the vaporisation process. For example, the heating element may be a wire coil wrapped around a central wick.

An aim of these arrangements is to maximise the amount of vaporized source liquid delivered with each inhalation (puff). This can be achieved by increasing the heat output of the heating element so that more source liquid is vaporized during the duration
15 of a puff. Reducing the electrical resistance of the heater, for example by using a lower resistance wire to form a heating element, allows more current to flow for a given battery voltage, thereby increasing the power consumed by the heater and generating more heat. This approach leads to particular challenges, however.

To lower the resistance one may increase the diameter of the heating wire. An
20 increased amount of source liquid should be delivered by the wick to feed the higher vaporisation rate enabled by the higher heater power; this requires a larger size of wick. These factors can reduce efficiency, however, because of heat conduction from the heater into the wick material, and the requirement to heat a larger mass of heater.

Also, achievable rates of vapour production may be limited by the speed at which
25 vapour moves into the inhalable airstream. Vaporization of the source liquid occurs at the interface of the heater and the wick. With a central wick inside a heater coil, the vapour has to travel from the interface out beyond the heater surface to be collected for inhalation. A reduced heater resistance to increase the power combined with the limited interface area may create a vaporization so intense that the vapour cannot escape quickly
30 enough and instead forms pockets at the interface that impede liquid contact with the heater. This reduces the efficiency of vapour production, causing the heater temperature to rise because the power is not being utilised for vaporisation. This can degrade the quality of the vapour and may lead to undesirable by-products.

Alternative wick and heater arrangements are therefore of interest.

35 **Summary**

According to a first aspect of some embodiments described herein, there is provided a sub-assembly for an electronic vapour provision system comprising: a source

P108644GB: BAT P13115314

of liquid for vaporisation; and a vaporizer for vaporising a portion of the liquid for inhalation by a user, the vaporizer comprising: a wick component; and an electrical heating element embedded in the wick component; wherein the wick component comprises a sheet of a porous electrically-insulating material and is arranged to wick
5 liquid from the source of liquid to a surface of the wick component adjacent to the embedded electrical heating element for vaporisation.

The porous electrically-insulating material may comprise a porous ceramic. The wick component may have a porosity in the range of 30% to 85%, and may have a thickness at least 50 times less than a longest dimension of the wick component.

10 The heating element may have an embedded shape including one or more bends and a length embedded in the wick component of between 2 and 20 times the longest dimension of the wick component. The one or more bends may define adjacent portions of the heating element that have a centre-to-centre spacing not greater than twice an embedded width of the heating element. The thickness of the wick component may be in
15 the range of 105% to 250% of an embedded width of the heating element. The heating element may be embedded substantially centrally with respect to the thickness of the wick component. The heating element may comprise a metallic wire.

The wick component may be substantially planar. The vaporiser may be supported in a vaporisation chamber by one or more parts of the wick component passing through
20 apertures in one or more walls of the vaporisation chamber to extend into the source of liquid. One or more parts of the wick component that pass through apertures in one or more walls of the vaporisation chamber may be at opposite sides of the wick component. The vaporizer may be supported in the vaporisation chamber such that a thinnest profile of the wick component is presented to a direction of airflow through the vaporization
25 chamber. The source of liquid may comprise a reservoir having an annular shape and surrounding the vaporisation chamber. The wall of the vaporisation chamber may be also an inner wall of the reservoir.

The sub-assembly may be a cartomiser for an electronic vapour provision system.

30 According to a second aspect of some embodiments described herein, there is provided an electronic vapour provision system comprising a sub-assembly according to the first aspect.

According to a third aspect of some embodiments described herein, there is provided a method of making a vaporizer for an electronic vapour provision system, the method comprising: forming an electrically conductive heating element; arranging
35 powdered ceramic material around the heating element in a desired shape for a wick component; and sintering the ceramic material to form a porous ceramic wick component with the heating element embedded therein.

P108644GB: BAT P13115314

According to a fourth aspect of some embodiments described herein, there is provided a method of making a vaporizer for an electronic vapour provision system comprising: forming an electrically conductive heating element; arranging the heating element between a first layer and a second layer of sheet porous electrically-insulating material; and bonding the first layer and the second layer together to form a porous wick component with the heating element embedded therein.

In the method aspects, forming the conductive heating element may comprise shaping a metallic wire or depositing a conductive ink into a path with one or more bends, and a length between 2 and 30 times the intended longest dimension of the wick component. The one or more bends may define adjacent portions of the wire that have a centre-to-centre spacing not greater than twice a width of the wire. The methods may further comprise mounting the completed vaporizer in a vaporisation chamber by passing one or more edges of the wick component through one or more apertures in a wall of a vaporisation chamber.

According to a fifth aspect of some embodiments described herein, there is provided an electronic vapour provision device including a reservoir for source liquid and a vaporisation chamber adjacent the reservoir in which source liquid can be vaporized, the vaporisation chamber housing a vaporizer comprising: a porous ceramic wick component; and a metallic heater element embedded in the wick component and connectable to a battery in the electronic vapour provision device; wherein two ends of the wick component pass through apertures in walls of the vaporisation chamber to suspend the vaporizer across the vaporisation chamber, the two ends penetrating into the reservoir to absorb source liquid and transport it to the heating element by capillary action through pores in the wick component.

These and further aspects of certain embodiments are set out in the appended independent and dependent claims. It will be appreciated that features of the dependent claims may be combined with each other and features of the independent claims in combinations other than those explicitly set out in the claims. Furthermore, the approach described herein is not restricted to specific embodiments such as set out below, but includes and contemplates any appropriate combinations of features presented herein. For example, an electronic cigarette, a sub-assembly or a vaporizer may be provided in accordance with approaches described herein which includes any one or more of the various features described below as appropriate.

Brief Description of the Drawings

Various embodiments will now be described in detail by way of example only with reference to the accompanying drawings in which:

P108644GB: BAT P13115314

Figure 1 shows a schematic representation of an electronic cigarette with which a vaporizer according to embodiments of the invention may be used;

Figure 2 shows a perspective view of an example vaporizer;

Figure 3 shows a cross-sectional view through the example vaporizer of Figure 2;

5 Figures 4a, 4b and 4c show schematic plan views of further example vaporizers;

Figure 5A shows a perspective exploded side view of an example vaporisation chamber having a vaporizer;

Figure 5B shows an end view of the vaporisation chamber of Figure 5A;

10 Figure 6A shows a perspective exploded side view of a vapour source comprising the vaporisation chamber of Figure 5A;

Figure 6B shows a perspective side view of the vapour source of Figure 6A;

Figure 7 shows a schematic side view of a further example vaporization chamber;

and

15 Figure 8 shows a schematic side view of a yet further example vaporization chamber.

Detailed Description

20 Aspects and features of certain examples and embodiments are discussed/described herein. Some aspects and features of certain examples and embodiments may be implemented conventionally and these are not discussed/described in detail in the interests of brevity. It will thus be appreciated that aspects and features of apparatus and methods discussed herein which are not described in detail may be implemented in accordance with any conventional techniques for implementing such aspects and features.

25 The present disclosure relates to aerosol provision systems, also referred to as vapour provision systems, such as e-cigarettes. Throughout the following description the term "e-cigarette" or "electronic cigarette" may sometimes be used; however, it will be appreciated this term may be used interchangeably with aerosol (vapour) provision system or device.

30 Figure 1 is a highly schematic diagram (not to scale) of an example aerosol/vapour provision system such as an e-cigarette 10 to which embodiments are applicable. The e-cigarette has a generally cylindrical shape, extending along a longitudinal axis indicated by a dashed line (although aspects of the invention are applicable to e-cigarettes configured in other shapes and arrangements), and comprises two main components, namely a body 20 and a cartridge assembly 30.

35 The cartridge assembly 30 includes a reservoir or source of liquid 38 containing a source liquid comprising a liquid formulation from which an aerosol is to be generated, for example containing nicotine, and a heating element or heater 36 for heating source liquid

P108644GB: BAT P13115314

to generate the aerosol. A wicking element or component or wick 37 is provided to deliver source liquid from the reservoir 38 to the heating element 36. A part or parts of the wick 37 are in fluid communication with source liquid in the reservoir 38 and by a wicking or capillary action source liquid is drawn along or through the wick 37 to a part or parts of the wick 37 which are in contact with the heater 36. Vaporization of the source liquid occurs at the interface between the wick 37 and the heater 36 by the provision of heat energy to the source liquid to cause evaporation, thus generating the aerosol. The source liquid, the wick 37 and the heater 36 may be collectively referred to as an aerosol or vapour source. The wick 37 and the heater 36 may be collectively referred to as a vaporizer or an atomiser 15. An atomiser/vaporizer may be arranged in a chamber or housing which is substantially sealed from the reservoir of source liquid to prevent or limit leakage of the source liquid into the chamber. The wick is the intended path for liquid from the reservoir to the heater. The inclusion of the vaporizer/atomiser within the cartridge assembly leads to the term "cartomizer" which is sometimes applied to this component of an electronic cigarette.

The cartridge assembly 30 further includes a mouthpiece 35 having an opening through which a user may inhale the aerosol generated by the vaporizer 15. The aerosol for inhalation may be described as an aerosol stream or inhalable airstream. As an example, the source liquid may comprise around 1 to 3% nicotine and 50% glycerol, with the remainder comprising roughly equal measures of water and propylene glycol, and possibly also comprising other components.

The body 20 includes a re-chargeable cell or battery 14 (referred to herein after as a battery) to provide power for the e-cigarette 10, and a printed circuit board (PCB) 28 and/or other electronics for generally controlling the e-cigarette 10. The body can therefore also be considered as a battery section, or a control unit or section. In use, when the heater 36 receives power from the battery 14, as controlled by the circuit board 28 possibly in response to pressure changes detected by an air pressure sensor (not shown), the heater 36 vaporizes source liquid delivered by the wick 37 to generate the aerosol, and this aerosol stream is then inhaled by a user through the opening in the mouthpiece 35. The aerosol is carried from the aerosol source to the mouthpiece 35 along an air channel (not shown in Figure 1) that connects the aerosol source to the mouthpiece opening as a user inhales on the mouthpiece. To this end, the vaporizer 15 may be accommodated in a vaporizer chamber (not shown) that is comprised within, or otherwise connected to, an airflow pathway through the e-cigarette 10.

In this particular example, the body 20 and cartridge assembly 30 are detachable from one another by separation in a direction parallel to the longitudinal axis, as shown in Figure 1, but are joined together when the device 10 is in use by cooperating engagement

P108644GB: BAT P13115314

elements 21, 31 (for example, a screw or bayonet fitting) to provide mechanical and electrical connectivity between the body 20 and the cartridge assembly 30, in particular connecting the heater 36 to the battery 14. An electrical connector interface on the body 20 used to connect to the cartridge assembly 30 may also serve as an interface for connecting the body 20 to a charging device (not shown) when the body 20 is detached from the cartridge assembly 30. The other end of the charging device can be plugged into an external power supply, for example a USB socket, to charge or to re-charge the battery 14 in the body 20 of the e-cigarette. In other implementations, a separate charging interface may be provided, for example so the battery 14 can be charged when still connected to the cartridge assembly 30.

The e-cigarette 10 is provided with one or more holes (not shown in Figure 1) for air intake, indicated by the arrows A. These holes, which are in an outer wall of the body 20 (but which in other examples may be in an outer wall of the cartridge assembly 30), connect to an airflow path through the e-cigarette 10 to the mouthpiece 35. The airflow path may include a pressure sensing region (not shown in Figure 1) in the body 20, and then connects from the body 20 into cartridge assembly 30 to a region (such as the vaporizer chamber) around the heating element 36 so that when a user inhales through the mouthpiece 35, air is drawn into the airflow path through the one or more air inlet holes. This airflow (or the resulting change in pressure) is detected by a pressure sensor (not shown in Figure 1) in communication with the airflow path that in turn activates the heater 36 (via operation of the circuit board 28) to vaporize a portion of the source liquid at the wick-heater interface to generate the aerosol. The airflow passes through the airflow path, and combines with the vapour in the region around the heater 36, and the resulting aerosol (combination of airflow and condensed vapour) travels as an aerosol stream along the airflow path connecting from the region of the heater 36 to the mouthpiece 35 to be inhaled by a user.

In some examples, the detachable cartridge assembly 30 may be disposed of when the supply of source liquid is exhausted, and replaced with another cartridge assembly if so desired. In other examples the reservoir may be refillable with more source liquid. The body 20 may be intended to be reusable by recharging of the battery, for example to provide operation for a year or more by connection to a series of disposable detachable cartridges assemblies. In other examples, both the cartridge assembly and the body may be disposable, and may not be detachable from each other. Also, the various components may be located differently from the Figure 1 example, and the cartridge assembly and the body may be connectable in a different configuration such as a side-by-side arrangement instead of the longitudinal arrangement of Figure 1. Embodiments of the invention are applicable to these and other various alternatives.

P108644GB: BAT P13115314

According to embodiments of the invention, it is proposed to configure the vaporizer (atomiser) by embedding the heating element inside a porous wick component.

Figure 2 shows a perspective view of a vaporiser 15 according to a first example embodiment. The wick or wicking element or component 37 is a thin flat planar substrate of an electrically-insulating porous material such as porous ceramic, having a thickness t , a length l and a width w . Embedded within the wick 37 is a heating element 36 in the form of a conductive (metallic) wire 39. This is shown in a phantom dotted line to indicate its position inside the wick. Each end 36a of the heating element 36 terminates at an edge of the wick 37 in a connecting lead 40 by means of which the heating element 36 can be connected (typically via an arrangement of contacts and other electrical wires and connections, and under control of a PCB or other control electronics) to an electrical power supply within an e-cigarette, such as the battery 14 in Figure 1. The leads 40 and the wire 39 can be formed from a single length of wire, or may be separately fabricated and then connected for example by welding (such as for ease of fabrication or to utilise particular properties of different wires).

The heating element wire 39 is formed into a serpentine or zigzag shape between its two ends 36a. The wire formation occupies a single plane which is arranged substantially mid-way through the thickness t of the wick 37 so as to be substantially equidistant from the upper 37a and lower 37b (with reference to the illustrated orientation) surfaces of the wick 37 (main surfaces). In this way, heat from the heating element 36 when powered by electric current can be delivered roughly equally to each main surface 37a, 37b. If the zig-zags or adjacent turns of the wire 39 are closely spaced so that all parts of the wick substrate are relatively close to part of the wire, heat can be delivered rapidly to all parts of the wick. A larger spacing between wire turns may lead to a wasted volume of wick material that takes up heat energy but does not attain a sufficient temperature for vaporisation.

Figure 3 shows a cross-sectional view through the vaporizer of Figure 2, along the line III. From this, the dense packing of the adjacent sections of the wire 39 inside the volume of the wick 37 is apparent. The wire 39 occupies a substantial proportion of the total volume of the vaporizer. Adjacent portions of the wire are separated by a distance d_2 less than the width d_1 (diameter) of the wire. Hence, the centre-to-centre spacing d_3 between adjacent wire portions is less than twice the wire width ($2 \times d_1$). Also, the depth or thickness d_4 of wick material between the main surfaces and the wire surface is less than the width of the wire d_1 . This thickness can be chosen having regard to the vaporisation rate; if there is too great a depth of wick material vaporisation will be impeded and insufficient vapour will escape from the wick surface. The invention is not limited to the above proportions, however, and greater or lesser size ratios may be used.

P108644GB: BAT P13115314

The relative volumes and dimensions of the heater and the wick, the depth of wick material overlying the heater wire and the porosity of the wick material can be variously selected to deliver a sufficient volume of source liquid to feed the available vaporisation rate while also allowing the vapour to escape from the wick material at a fast enough rate.

5 For example, the embedded heater may have a volume that is at least 50% of the combined volume of the embedded heater and the wick (defined by the outer dimensions of the wick element), or between 40% and 60%, or between 30% and 70%. Alternatively, the combined volume may be confined to a zone of the wick over which the heater extends, for example a central zone or an end zone, with a relatively large further amount
10 of the wick extending beyond this zone such as to ensure a significant wick volume reaching into a reservoir, or to reach the walls of the vaporisation chamber if it is desired for vaporisation to be kept remote from the walls. The part of the wick within which the heater is embedded (the combined volume) can be considered as a heating zone, where all or most of the vaporisation occurs. The heating zone may comprise all or most of the
15 wick, or just a part of it.

In this example the wick 37 is formed from a rigid porous ceramic material. The pores of the ceramic allow a wicking action so that when part of the wick is placed in fluid communication with a source liquid reservoir, source liquid in the reservoir is drawn
20 through the pores to the wire 39. When the heater 37 is activated, heat is transferred to source liquid in direct contact with the wire 39 and also via intervening wick material. The resulting vapour passes through the pores to the wick surfaces 37a, 37b and out into the surrounding air to be collected by air flowing in the airflow path.

The wire 39 is embedded within the wick substrate 37. By "embedded" is meant that the material of the wick wholly covers and is in contact with substantially all the outer
25 surface of the wire within the volume of the wick (subject to gaps where pores in the wick material are immediately adjacent to the wire). At each axial cross-sectional position along the wire, the porous ceramic material is in contact with the wire around its the full circumference; the wire is wholly enveloped in the wick material. This contact between the wire and the wick is the interface at which the majority of the vapour formation happens,
30 so an embedded configuration maximises the interface area for a given length of wire, and greatly increases the interface area compared with vaporizer arrangements in which a coiled heater wire is wrapped around a central wick, for example. A thinner wire with more turns or bends (to increase the length) might provide a larger interface area but this may need to be balanced against the beneficial lower resistance and higher power output
35 of a thicker wire.

Although a fully embedded arrangement in which the wick material covers the wire completely gives a maximum vaporisation interface, a partially embedded configuration in

P108644GB: BAT P13115314

which the heating element is at least partly exposed at one or both main surfaces of the wick substrate might be considered useful in some circumstances.

The heating element in the form of a wire 39 can be fabricated in any shape between the two ends 36a. A shape which maximises the length of the wire that can be accommodated within the wick volume gives a largest vaporisation interface; this might be achieved by any convoluted path between the two ends. Such a path has a non-linear shape. For example, the shape may be an angular or a curved serpentine shape, an angular or curved zig-zag, or an angular or curved spiral, and the shape may be regular (repeating) or irregular. Incorporation of a plurality of turns, bends or corners into the shape will increase the available length. In some embodiments, the embedded conductive length of the heating element between its two ends is several or many times the longest dimension of wick element, achieved by including a plurality of turns, bends, corners or folds along the length in the heating element. For example, the heating element may have a length which is between 2 and 20 times or between 5 and 10 times the length of the longest dimension (edge) of the wick element. The two ends may be located at edge surfaces of the wick (the same edge, as in Figure 2, or different edges) or on one or both main surfaces (which may be convenient for a spiral or other shape where the heating element terminates away from a wick edge). The adjacent lengths of the wire may be as closely spaced as is conveniently achievable with the chosen manufacturing process and materials for fabricating the vaporizer, to maximise the length of useable wire. However, care should be taken that no parts of the wire are touching each other within the wick, so as to avoid an electrical short circuit. A complex shape is not essential, though, and the wire may be substantially straight (linear) or gently curving between its two ends if this is deemed to deliver sufficient heating power, or if an elongate wick is preferred. This might provide a heating element that is between 1 and 2 times the length of the wick's longest side, for example.

Figures 4a, 4b and 4c show schematic plan views of various examples of vaporizers with differently shaped heating element wires. The example of Figure 4a has a square wick element 37 and a heating wire 39 arranged as a double spiral so that both ends 36a can be located at the same edge of the wick. The connecting leads are omitted for simplicity. The example of Figure 4b has a rectangular wick element 37 and a heating wire 39 in an angular, cornered, shape that is folded back on itself a plurality of times. The ends 36a are on different edges of the wick 37. The example of Figure 4c shows a highly linear wick element 37, having a length many times greater than its width, and a heating wire 39 configured as a simple straight line between its two ends 36a at opposite short edges of the wick 37.

P108644GB: BAT P13115314

The heating element need not be formed from conductive wire (such as by bending). An appropriate shape that provides a conductive path of the desired length might be stamped, cut or pressed out of sheet metal, or a metallic ribbon (rather than a wire) might be bent into a suitable shape, for example.

5 Suitable conductive materials for the heating element include any resistive metal, for example nichrome, steel, titanium or other metals and metal alloys. Other materials may also be used, such as conductive ink (non-metal or metal based), printed, drawn or deposited along a suitably shaped path.

10 The wick element may have various properties. It is formed from a porous material to enable the required wicking or capillary effect for drawing source liquid through it from a source liquid reservoir (where the wick meets the source liquid at a reservoir contact site) to the vaporisation interface. Porosity is typically provided by a plurality of interconnected or partially interconnected pores (holes or interstices) throughout the material, and open to the outer surface of the material. Any level of porosity may be employed depending on
15 the material, the size of the pores and the required rate of wicking. For example a porosity of between 30% and 85% might be selected, such as between 40% and 70%, between 50% and 80%, between 35% and 75% or between 40% and 75%. This might be an average porosity value for the whole wick element, since porosity may or may not be uniform across the wick. For example, pore size at the reservoir contact site might be
20 different from pore size nearer to the heater.

 The wick element has a substantially thin flat shape. For example it may be considered as a sheet, layer, film, substrate or the like. By this it is meant that a thickness of the wick (the dimension t in Figure 2) is less or very much less than at least one of the length (l in Figure 2) and the width (w in Figure 2) of the wick. Thus, the wick thickness (its
25 smallest dimension) is less or very much less than the longest dimension. This enables the heating element to be close to the main surfaces of the wick, with the depth of overlying wick material being slight. The thickness may or may not be substantially uniform. For example, the wicking rate may be modified by a reduced or increased thickness at the reservoir contact site compared with the remainder of the wick. The wick
30 may be planar, as in Figures 2 and 3, but its shape is not limited in this regard. The "flat" characteristic is intended to have a topological definition, in that the wick may form a curved surface such a cylinder (tube), a trough or a segment of a spherical surface or other dish-like form. The thickness of the wick may, for example, be in the range of 105% to 250% of the thickness of the heater element (the diameter of a wire used as the heater
35 element, for example), such as between 105% and 200%, or 105% and 150%, or 110% and 200%, or 110% and 150%, or 120% and 200%, or 120% and 150%. The thickness of the wick may, for example, be in the range 50 to 200 times less than the longest

P108644GB: BAT P13115314

dimension of the wick (typically the length). For example the length l might be 50 to 150 times the thickness t , or 50 to 100 times, or 50 to 150 times, or 100 to 150 times, or 100 to 200 times. As an example, the wick might be rectangular with a length l in the range 5 mm to 15 mm, a width w in the range 5 mm to 15 mm, and a thickness t somewhat in excess of a wire thickness of 0.1 mm, such as 0.12 mm to 0.2 mm. The invention is not limited in this regard, however, and other dimensions, shapes and proportions of the wick may be used.

It is useful for the wick to have sufficient rigidity to support itself in a required position within the vapour source. For example, it may be mounted at or near one or two edges and be required to maintain its position substantially without flexing, bending or sagging. The rigidity may arise from the wick material in the selected wick thickness (so that an appropriate thickness is used to provide this characteristic), and where the wick is able also to support the heater embedded in it. In other examples, some structural rigidity may be derived from the heater itself, so that the heater aids in supporting the mounted wick in its required position. The overall rigidity of the wick and heating element combination may be relied upon, or the rigidity of the wick alone. The term rigid is considered to imply that the wick or vaporizer is substantially non-flexible or non-pliant.

As an example, porous ceramic is a useful material to use as the wick element. Any ceramic with appropriate porosity may be used. However, the invention is not so limited, and any electrically-insulating material having the same or similar properties or characteristics might be used. In general, the porous material should be considered as a "solid" or "hard" material, in contrast to "soft" fabric and fibrous materials, such as cotton and other fibres which are often used in the art as wicks and to absorb stores of source liquid in place of a reservoir of free-flowing liquid. In this context, the solid wick material is substantially non-compressible.

A vaporizer of the kind described herein may be fabricated in a straightforward manner. If porous ceramic is chosen as the porous wick material, this is available as a powder which can be formed into a solid by sintering (heating to cause coalescence, possibly under applied pressure). Thus, the heating element can be fabricated first (bending a wire into the appropriate shape, for example), and the ceramic powder can be arranged around the heating element in the desired shape, such as by filling a mould that has the heating element suspended or otherwise arranged inside it. Sintering then solidifies the ceramic to create the porous wick, with the heating element embedded in it. Fabricating the vaporizer in this way, by forming and shaping the wick element from wick material around the heating element, achieves the required embedded arrangement, giving close contact between the heating element and the wick at the vaporization interface.

P108644GB: BAT P13115314

Alternatively, the vaporizer may be formed from two separate layers of wick material with the heating element sandwiched between the two layers. After stacking the layers, the wick layers may be secured around the heating element by gluing, welding or other bonding methods, according to what is appropriate to the chosen wick material. The wick layers may be the same thickness, or different thicknesses. The heating element may be preformed to the desired shape, as mentioned above, or in the case of conductive ink, can be drawn or printed onto the surface of one wick layer before bonding the second wick layer on top.

A vaporizer in accordance with aspects of the invention may be used in conjunction with a reservoir of free flowing source liquid (although it may be combined with a reservoir of the type that is formed from a soft porous material such as cotton which is soaked with source liquid). It is envisaged that the vaporizer will be housed inside a vaporizer chamber which communicates with or forms part of the airflow channel through an electronic cigarette but which is substantially sealed against the ingress of free source liquid from an adjacent reservoir. The wick of the vaporizer forms the path for source liquid to enter the vaporizer chamber; this is achieved by arranging that a part of the wick (one or more edges, for example) extends through a wall of the chamber into the reservoir. A seal can be arranged around the wick where it traverses the wall, to limit leakage into the chamber. The part of the wick including the embedded heating element lies inside the chamber so that air flowing along the airflow channel can pick up vaporized source liquid given off from the vaporizer when the heating element is activated (electrical current is passed through it).

Figure 5A shows a perspective side view of an example vaporisation chamber 50. The chamber 50 has walls defined by a hollow tube 52 (cylindrical in this example, but other cross-sectional shapes may be used if preferred). The tube 52 is part of the air flow path through the electronic cigarette, and the aerosol stream carrying the vaporized source liquid exits the end of the tube as shown by the arrow A, to enter a next part of the air flow path for travel to the electronic cigarette's mouthpiece (not shown). At its lower end (as illustrated) the tube 52 is sealable by being joined to base portion 54 (indicated by the small arrow). The base portion 54 has a screw thread connector 56 for mechanical and electrical connection to a battery section (not shown). The base portion 54 has an air inlet 58 by which air is drawn into the vaporisation chamber 50 when a user inhales on the electronic cigarette. One or more air inlets 58 may be provided, possibly in locations other than on a separate base portion 54, and they may be provided with an adjustment mechanism to deliver variable ventilation into the electronic cigarette. The base portion 54 need not be separate from the tube 52; the two components may be formed integrally.

P108644GB: BAT P13115314

A vaporizer 15 according to aspects of the invention is disposed inside the vaporisation chamber 50. The wick element of the vaporizer 15 has an elongate shape (a rectangle in this example) which is longer than the width (diameter) of the tube 52. Thus, the wick extends across the full width of the tube and beyond, so that opposite end portions 16 of the wick pass through the tube walls in a sealed configuration and lie outside the vaporisation chamber 50. The vaporizer is thus suspended across the vaporisation chamber. One end portion 16 can be seen in Figure 5A protruding from the chamber wall. Electrical connection leads 40 are connected to the heating element at parts of the wick inside the chamber, so that they can be connected appropriately in the base portion 54 to receive current from a battery via the screw thread connector 56. In this way, air drawn in through the air inlet 58 passes over and past the vaporizer 15 as it travels along the tube 52, thereby collecting vapour to form the aerosol stream.

Figure 5B shows a view of the vaporisation chamber looking into the tube 52 along its length. The vaporizer 15 can be seen mounted through opposite apertures in the tube walls such that its central part 17 is inside the chamber, extending fully across the tube 52, and its opposite ends 16 are outside the chamber. In an example, the protruding end portions have a protruding length of up to 2 mm, for example between 1 and 2 mm.

The ends of the wick are arranged to protrude through the walls of vaporisation chamber so that they can carry source liquid to the heating element. This is achieved by locating a reservoir for the source liquid externally to the vaporisation chamber.

Figure 6A shows a perspective view of parts of a vapour source comprising a reservoir, and the vapour chamber 50 and vaporizer 15 of Figure 5A. An outer tube 60 of larger width (diameter) than the tube 52 forming the vaporisation chamber walls is provided, and is sized to fit over and around the tube 52 as shown by the arrow, leaving an annular space between the inside of the outer tube 60 and the outside of the inner tube 52. The outer tube 60 may or may not form part of the outer surface of the electronic cigarette. The outer tube 60 connects to the vaporizer base portion 54 which acts to seal a first (lower, as illustrated) end of the annular space. The outer tube 60 is closed at its second (upper, as illustrated) end by a top wall 61, through which extends an outlet tube 62 which is in airflow communication with the interior of the inner tube 52 to enable the aerosol stream to leave the vaporisation chamber. The outlet tube 62 may form the mouthpiece of the electronic cigarette, or may be an intermediate section of the air flow path that leads towards the mouthpiece.

The annular space defined between the outer tube 60 and the inner tube 52 is sealed to make it substantially leak-proof. It forms a reservoir for free-flowing source liquid, which can exit the reservoir only via capillary action along the wick of the vaporizer

P108644GB: BAT P13115314

15 (assuming no accidental or unintended leaks). The protruding ends 16 of the wick lie inside the reservoir, and hence absorb source liquid that is stored in the reservoir.

Figure 6B shows a perspective view the vapour source of Figure 6A in assembled form, when the outer tube 60 has been placed over the inner tube 52 and connected to the base 54, thereby defining the reservoir 64 in the intervening annular space. In this example the outer tube 60 forms the outside of the electronic cigarette and is made from a transparent material, and the inner tube 52 and vaporizer 15 are visible through it. This feature allows visibility of source liquid in the reservoir also, so a user can determine how much source liquid there is. In other examples the outer tube 60 can be made from opaque material, and/or may have a casing around it, so that the reservoir contents cannot be seen.

The Figures 6A and 6B device is merely an example, and the vaporizer may be mounted in a vaporisation chamber in any way that allows at least one part of it to reach into a reservoir to wick source liquid. The wick may extend wholly or partly across the vaporisation chamber. Either ends or edges (one or more) may extend through the chamber wall(s). Opposite ends or edges or adjacent ends or edges may be used for this. The extension through the wall(s) conveniently provides support for the vaporizer, and its level of rigidity may determine how much or many of its edges should be used in this way. Also, the rate at which source liquid needs to be transferred by the wick from the reservoir to the heating element will determine what proportion of the wick should extend into the reservoir. Two or more opposite or non-adjacent ends or edge parts may be considered useful since this increases the likelihood of contact between the wick and source liquid when the reservoir is partially empty, for example when the electronic cigarette is held at an angle. The vaporizer may be mounted so that the plane of the wick is orthogonal to the main air flow direction through the vaporisation chamber (as in Figures 5A, B and 6A, B). Alternatively, it may be mounted with its plane parallel to the air flow direction (imagine the vaporizer for Figure 5A rotated 90 degrees about its longitudinal axis), thereby presenting the smallest (thinnest or narrowest) profile of the wick element to the direction of air flow through the chamber. A parallel arrangement allows a larger vaporizer to be accommodated in the vaporisation chamber with less impediment to air flow (which would affect the "draw" as perceived by the inhaling user). Indeed, a parallel mounting allows a wick area inside the vaporisation chamber to be up to the size of the longitudinal cross-sectional area of the chamber, maximising the surface available for delivering vapour, and hence the aerosol production per puff.

Figure 7 shows a schematic representation of a vaporisation chamber with a parallel mounted vaporizer; the "edge-on" orientation enables a large wick surface area inside the chamber together with a small profile in the air-flow direction A. The two edges

P108644GB: BAT P13115314

16 of the wick that are parallel to the air flow direction protrude through the chamber walls for contact with source liquid in a surrounding reservoir.

As another example, the wick may be shaped as a tube and mounted in the vaporisation chamber end-on (edge-on) to the air-flow direction so that air flows through it. One or more radial arms can be provided to pass through the chamber walls into the reservoir. Formation of the wick from sintered porous ceramic allows flexibility in wick shape so that more complex forms such as this example can be realised.

Figure 8 shows a schematic representation of a vaporisation chamber with a tubular vaporizer 15, mounted through apertures in the chamber wall 52 by porous radial arms 18 terminating in end parts 16 that can reach into a surrounding reservoir.

The reservoir need not be configured as an annular space around the vaporisation chamber. It may be adjacent to the chamber, rather than around it, so that the reservoir and chamber have a side-by-side or above-and-below configuration. In such a case, likely only one end or edge of the wick would reach into the reservoir, but a curved wick shape could allow more than one edge for this. In any configuration, the reservoir may be immediately adjacent to the vaporisation chamber (conveniently they share one or more walls, so that the reservoir and chamber lie on opposite sides of a common wall). This is not essential however, and there may be intervening space between the reservoir and the vaporisation chamber than is bridged by part of the wick. Neither the vaporization chamber nor the reservoir need be defined by cylindrical walls; any shape for either volume may be used.

The vaporiser has been described in the context of being included within a cartomiser section of an electronic cigarette. However, the invention is not limited in this regard, and the vaporiser may be included otherwise within an electronic cigarette, in a portion which may or may not be intended to be disposable, and may or may not be intended to be separable by the user from another portion or portions of the electronic cigarette. Generally, therefore, the vaporiser is comprised within a sub-assembly of an electronic cigarette, where the sub-assembly may or not be a cartomiser, and may or may not be separable from the remainder of the electronic cigarette.

According to an embodiment a sub-assembly for an electronic vapour provision system, comprises: a reservoir for holding source liquid; a vaporisation chamber having an interior in airflow communication with an airflow path through the cartridge assembly; and a vaporizer comprising: a porous wick element with a thickness at least 50 times less than a longest dimension of the wick, such as in the range 50 to 200 times less than a longest dimension of the wick; and a heating element embedded in the wick element and connectable to an electrical power source; wherein the vaporizer is supported in the vaporisation chamber by one or more parts of the wick element passing through apertures

P108644GB: BAT P13115314

in a wall of the vaporisation chamber, the one or more parts extending into the reservoir such that source liquid in the reservoir is transported by wicking through the wick element to the heating element.

5 The various embodiments described herein are presented only to assist in understanding and teaching the claimed features. These embodiments are provided as a representative sample of embodiments only, and are not exhaustive and/or exclusive. It is to be understood that advantages, embodiments, examples, functions, features, structures, and/or other aspects described herein are not to be considered limitations on the scope of the invention as defined by the claims or limitations on equivalents to the claims, and that other embodiments may be utilised and modifications may be made
10 without departing from the scope of the claimed invention. Various embodiments of the invention may suitably comprise, consist of, or consist essentially of, appropriate combinations of the disclosed elements, components, features, parts, steps, means, etc., other than those specifically described herein. In addition, this disclosure may include
15 other inventions not presently claimed, but which may be claimed in future.

P108644GB: BAT P13115314

Claims

1. A sub-assembly for an electronic vapour provision system comprising:
a source of liquid for vaporisation; and
5 a vaporizer for vaporising a portion of the liquid for inhalation by a user, the
vaporizer comprising:
a wick component; and
an electrical heating element embedded in the wick component;
wherein the wick component comprises a sheet of a porous electrically-insulating
10 material and is arranged to wick liquid from the source of liquid to a surface of the wick
component adjacent to the embedded electrical heating element for vaporisation.
2. A sub-assembly according to claim 1, in which the porous electrically-insulating
material is a porous ceramic.
- 15 3. A sub-assembly according to claim 1 or claim 2, in which the wick component has
a porosity in the range of 30% to 85%.
4. A sub-assembly according to any one of claims 1 to 3, in which the wick
20 component has a thickness at least 50 times less than a longest dimension of the wick
component.
5. A sub-assembly according to any one of claims 1 to 4, in which the heating
element has an embedded shape including one or more bends and a length embedded in
25 the wick component of between 2 and 20 times the longest dimension of the wick
component.
6. A sub-assembly according to claim 5, in which the one or more bends define
adjacent portions of the heating element that have a centre-to-centre spacing not greater
30 than twice an embedded width of the heating element.
7. A sub-assembly according to any one of claims 1 to 6, in which the thickness of
the wick component is in the range of 105% to 250% of an embedded width of the heating
element.

35

P108644GB: BAT P13115314

8. A sub-assembly according to any one of claims 1 to 7, in which the heating element is embedded substantially centrally with respect to the thickness of the wick component.
- 5 9. A sub-assembly according to any one of claims 1 to 8, in which the heating element comprises a metallic wire.
10. A sub-assembly according to any one of claims 1 to 9, in which the wick component is substantially planar.
- 10 11. A sub-assembly according to any one of claims 1 to 10, in which the vaporizer is supported in a vaporisation chamber by one or more parts of the wick component passing through apertures in one or more walls of the vaporisation chamber to extend into the source of liquid.
- 15 12. A sub-assembly according to claim 11, in which the one or more parts of the wick component that pass through apertures in one or more walls of the vaporisation chamber are at opposite sides of the wick component.
- 20 13. A sub-assembly according to claim 12, in which the vaporizer is supported in the vaporisation chamber such that a thinnest profile of the wick component is presented to a direction of airflow through the vaporization chamber.
- 25 14. A sub-assembly according to any one of claims 11 to 13, in which the source of liquid comprises a reservoir having an annular shape and surrounding the vaporisation chamber.
- 30 15. A sub-assembly according to claim 14, in which the wall of the vaporisation chamber is also an inner wall of the reservoir.
- 35 16. A sub-assembly according to any one of claims 1 to 15, in which the sub-assembly is a cartomiser for an electronic vapour provision system.
17. An electronic vapour provision system comprising a sub-assembly according to any one of claims 1 to 16.

P108644GB: BAT P13115314

18. A method of making a vaporizer for an electronic vapour provision system, the method comprising:
- forming an electrically conductive heating element;
 - arranging powdered ceramic material around the heating element in a desired
 - 5 shape for a wick component; and
 - sintering the ceramic material to form a porous ceramic wick component with the heating element embedded therein.
19. A method of making a vaporizer for an electronic vapour provision system, the
- 10 method comprising:
- forming an electrically conductive heating element;
 - arranging the heating element between a first layer and a second layer of sheet porous electrically-insulating material; and
 - bonding the first layer and the second layer together to form a porous wick
 - 15 component with the heating element embedded therein.
20. An electronic vapour provision device including a reservoir for source liquid and a vaporisation chamber adjacent the reservoir in which source liquid can be vaporized, the vaporisation chamber housing a vaporizer comprising:
- 20 a porous ceramic wick component; and
- a metallic heater element embedded in the wick component and connectable to a battery in the electronic vapour provision device; wherein
- two ends of the wick element pass through apertures in walls of the vaporisation chamber to suspend the vaporizer across the vaporisation chamber, the two ends
 - 25 penetrating into the reservoir to absorb source liquid and transport it to the heating element by capillary action through pores in the wick component.

1/4

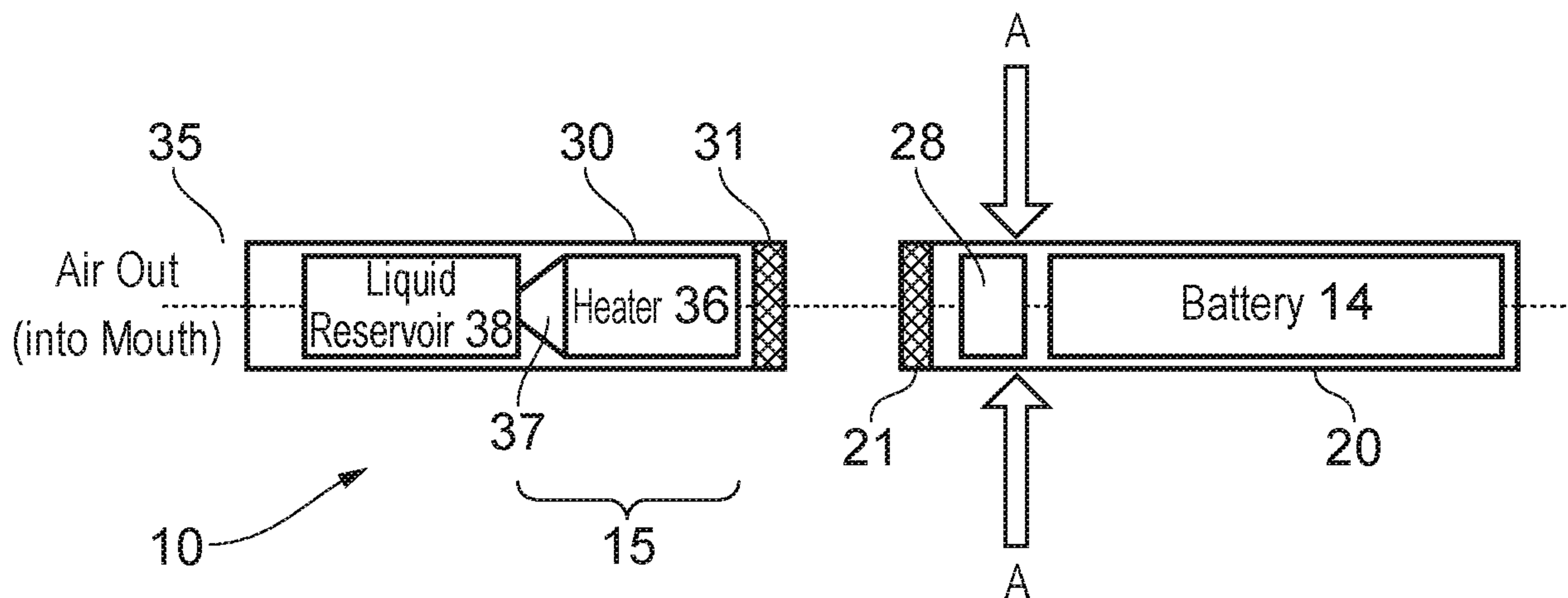

FIG. 1

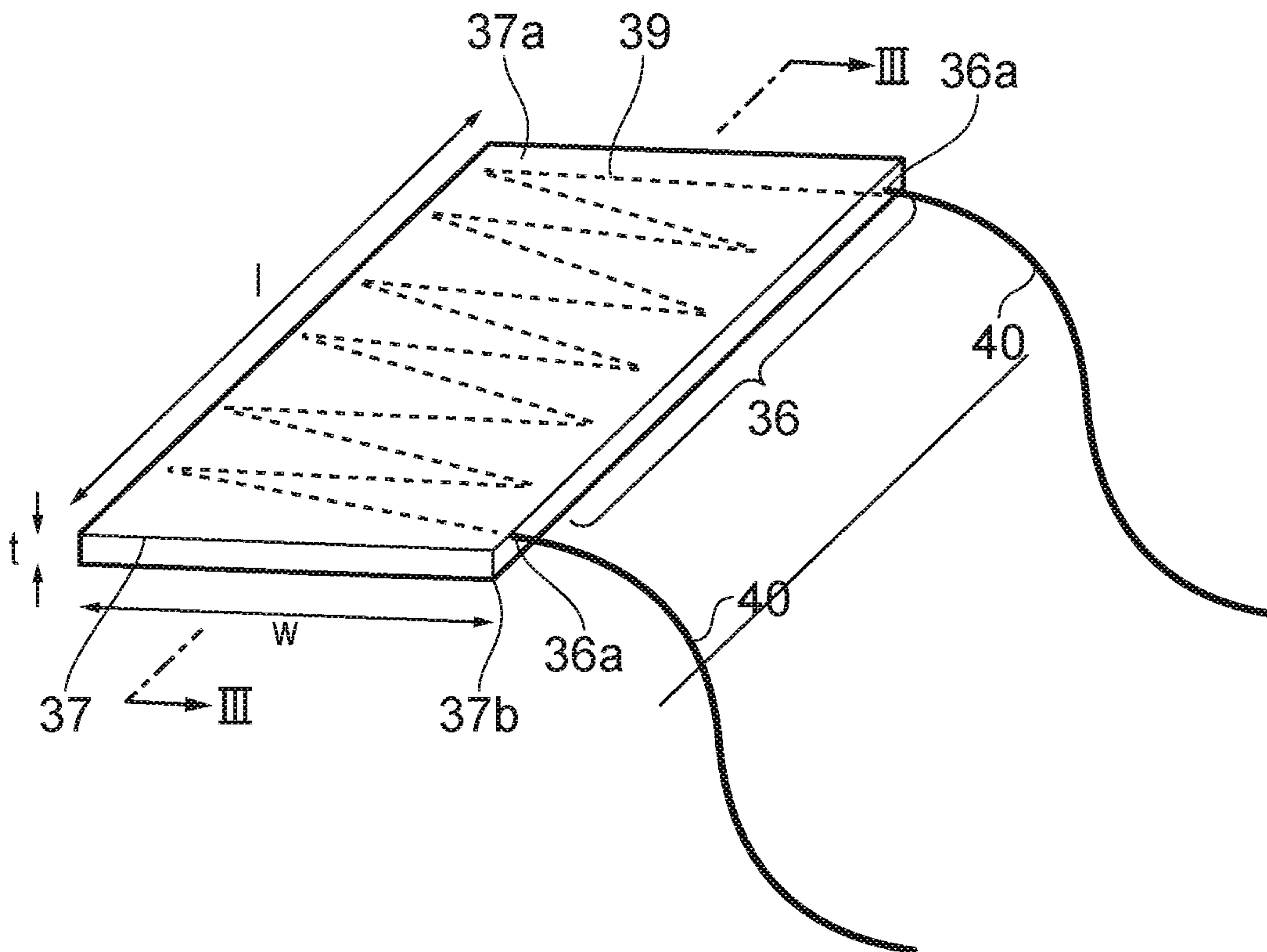

FIG. 2

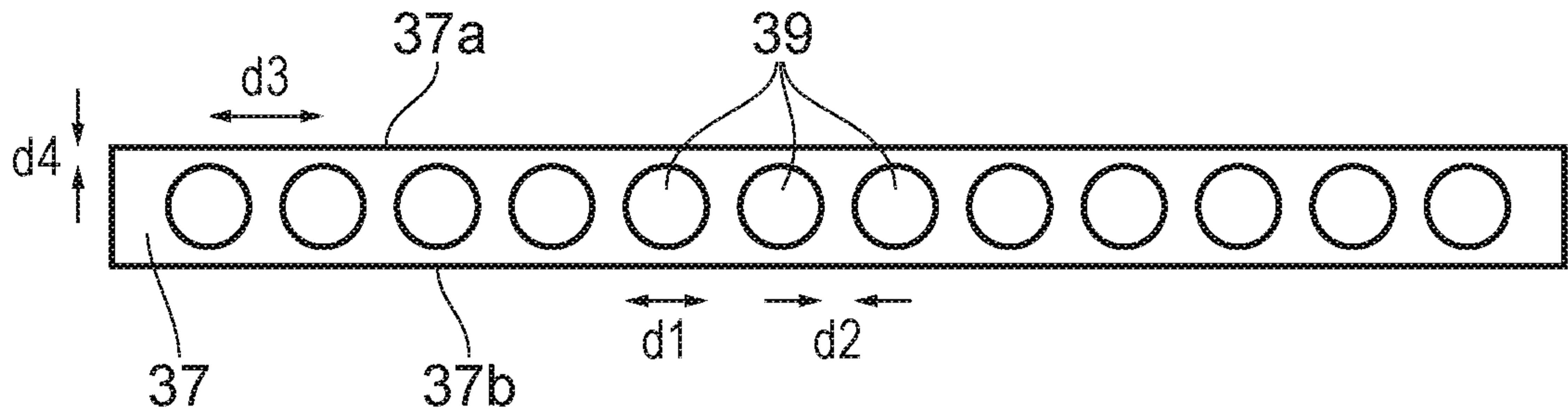

FIG. 3

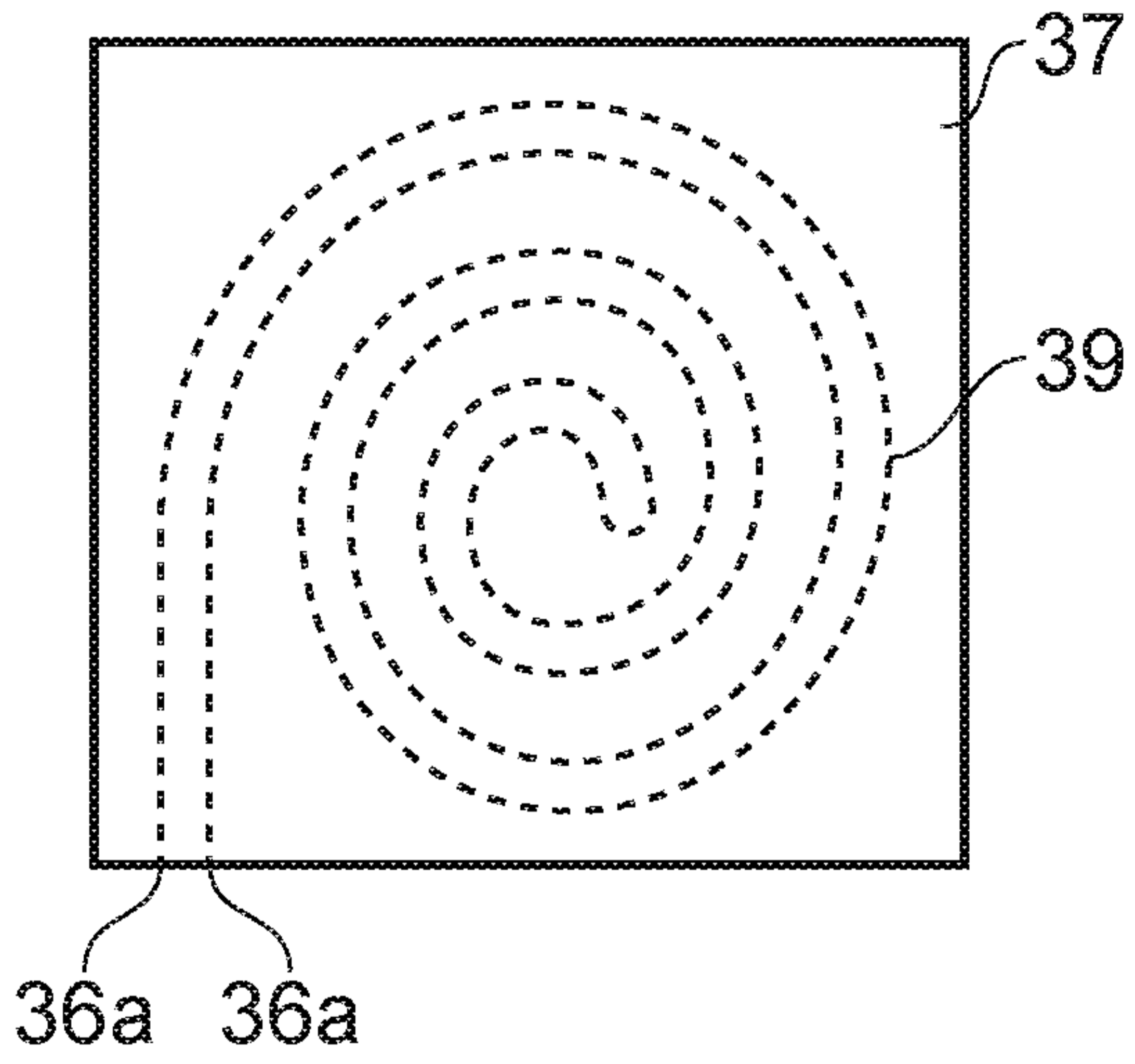

FIG. 4a

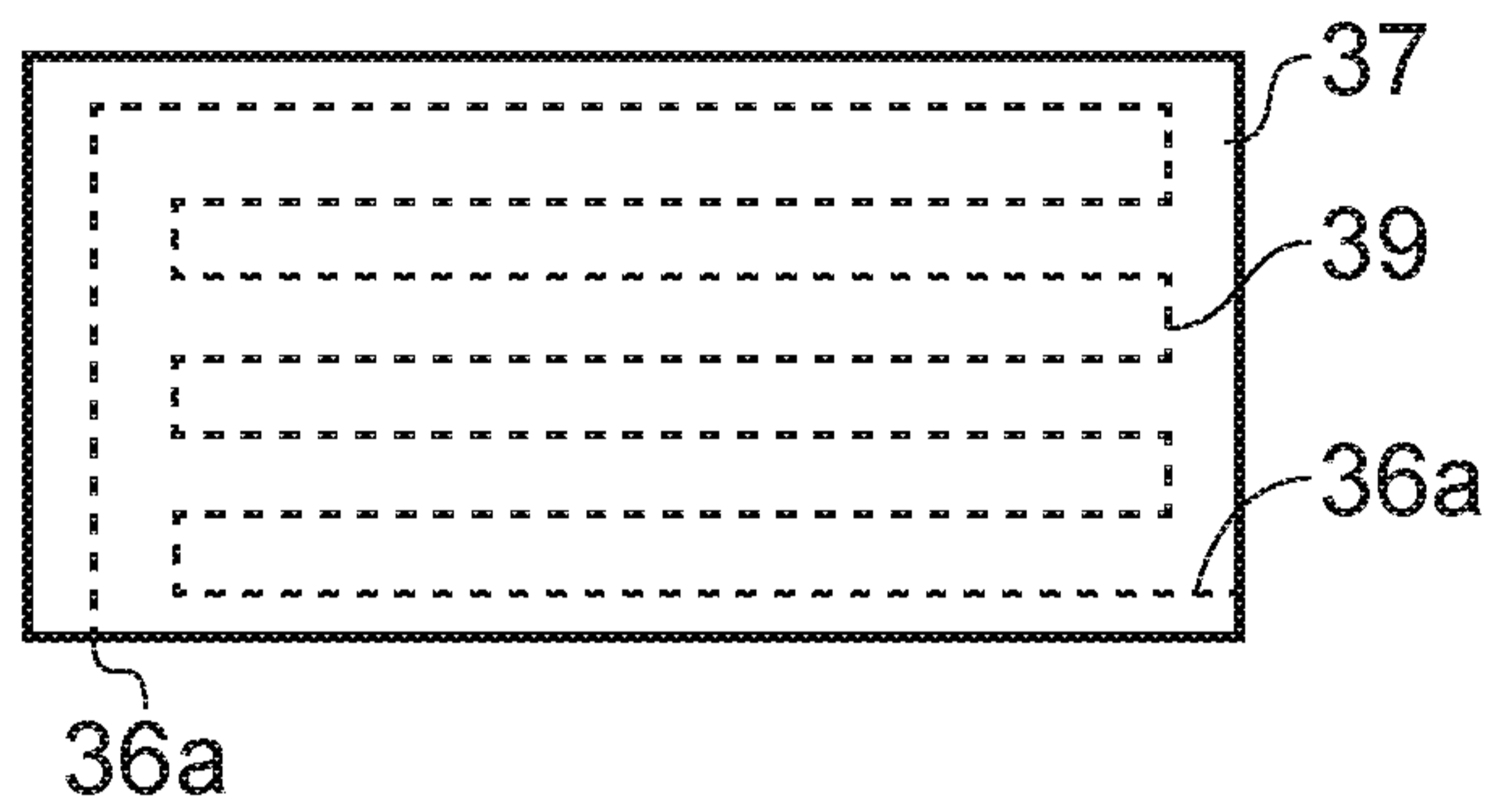

FIG. 4b

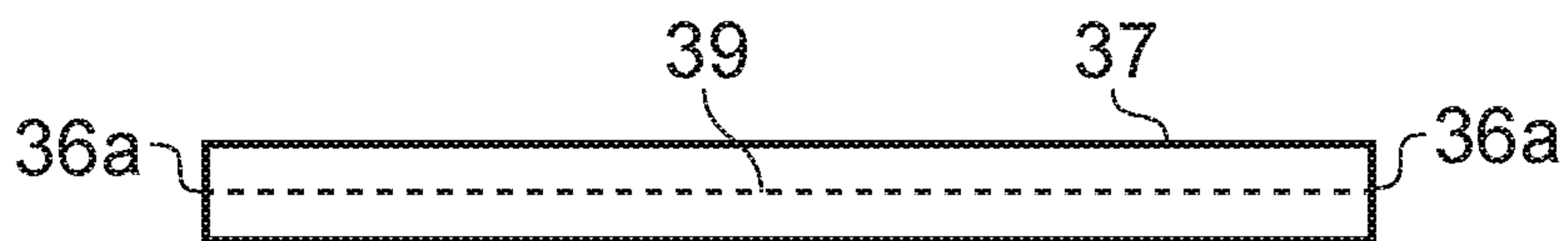

FIG. 4c

3/4

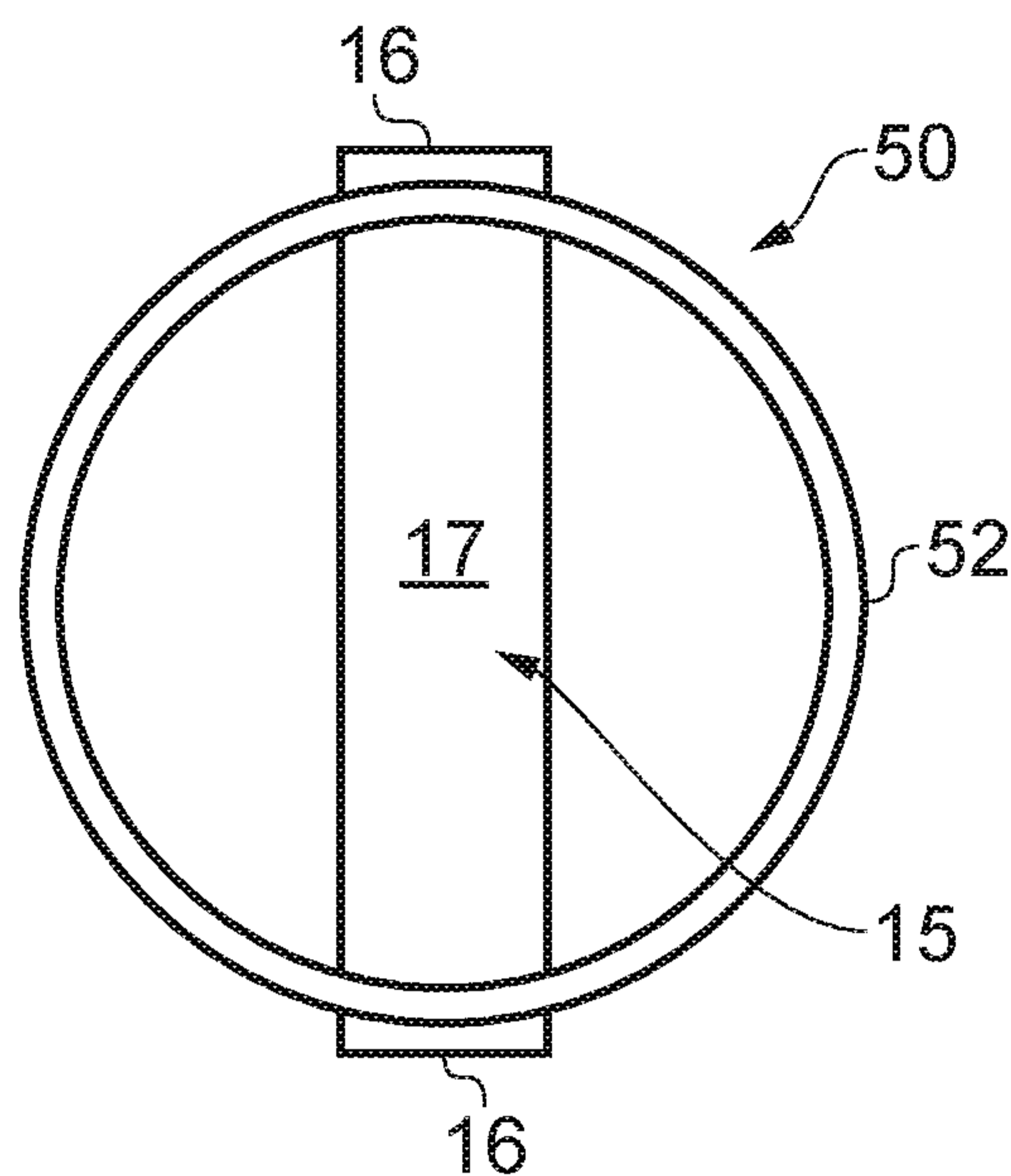
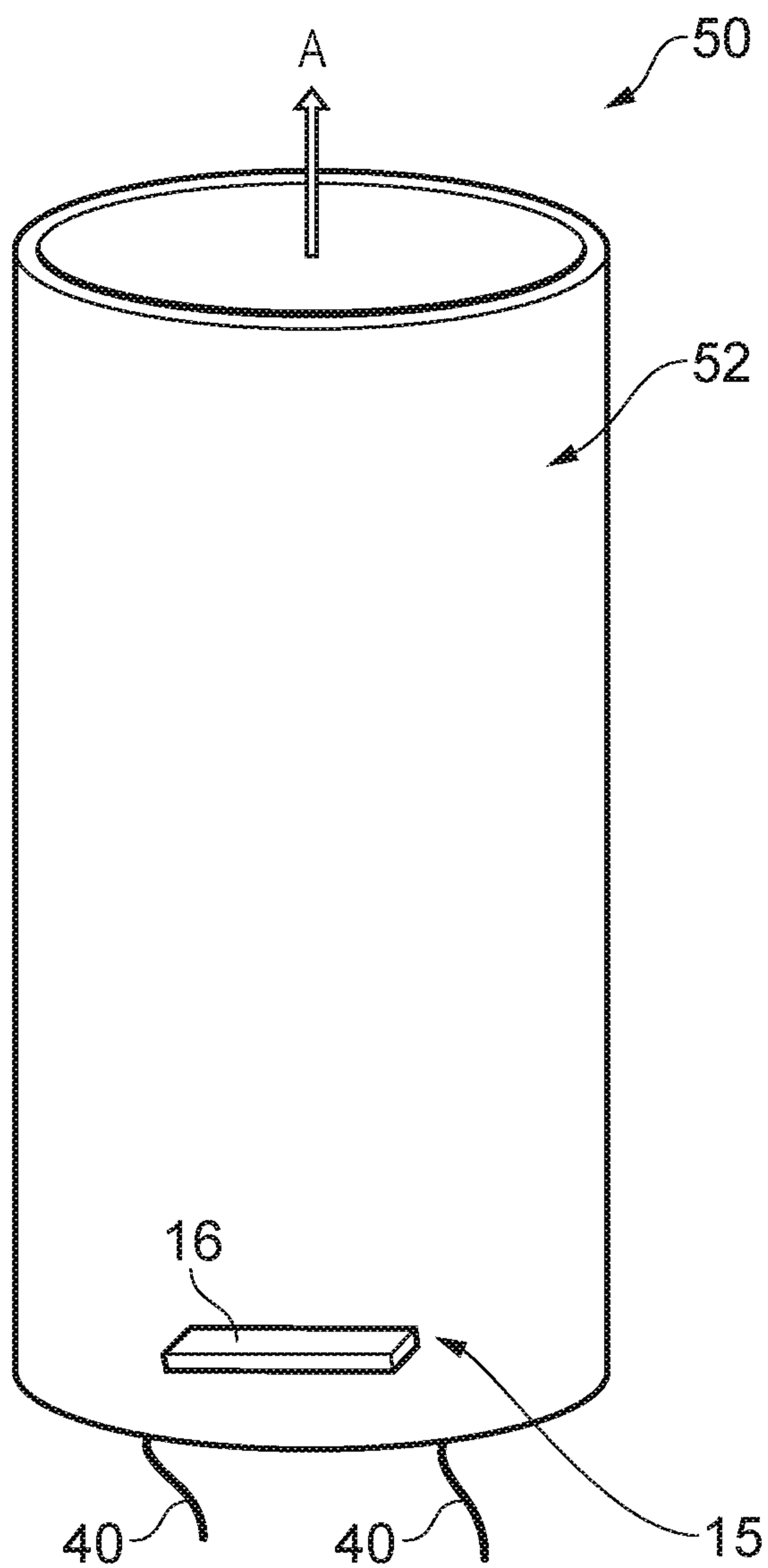

FIG. 5B

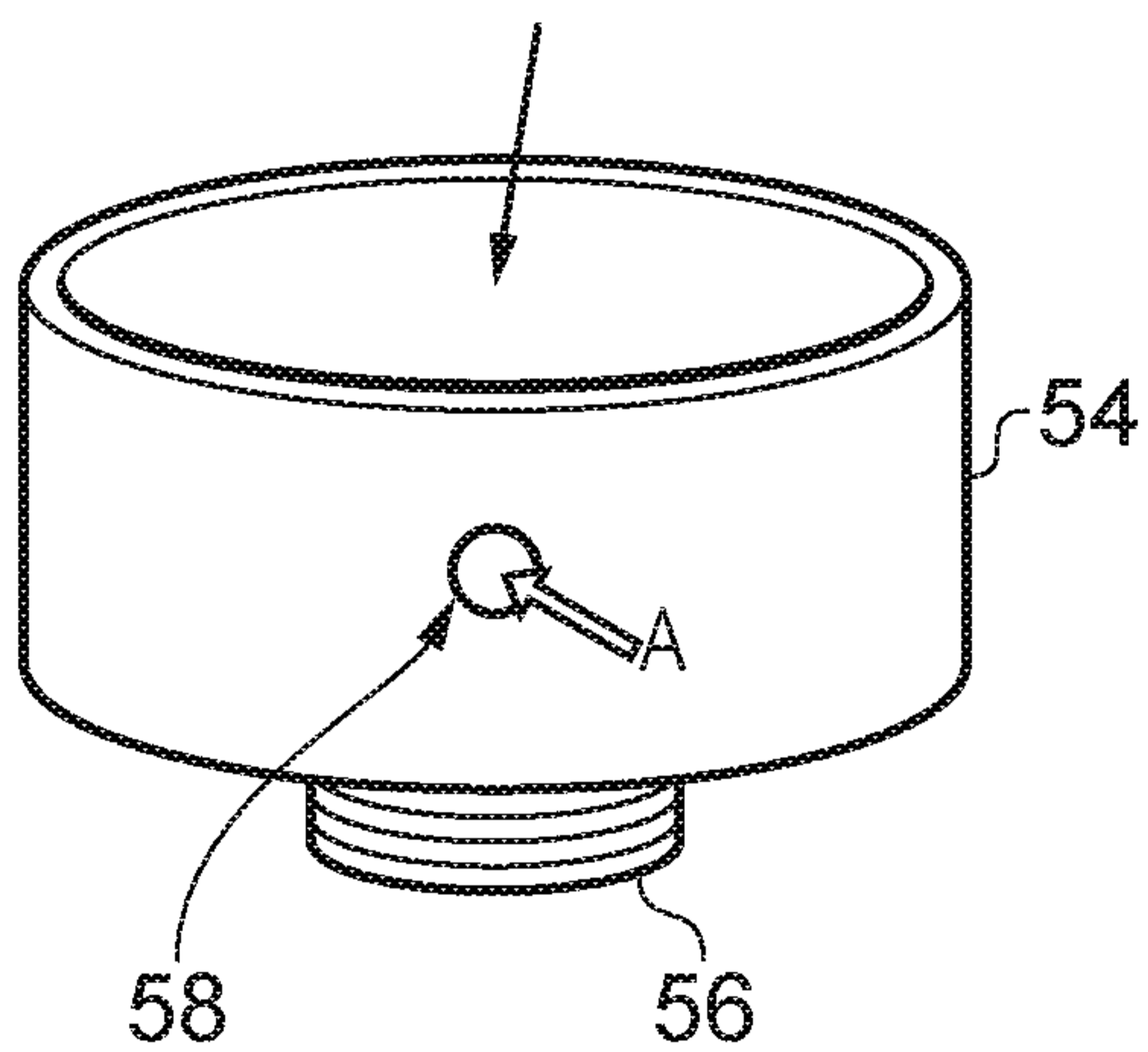

FIG. 5A

4/4

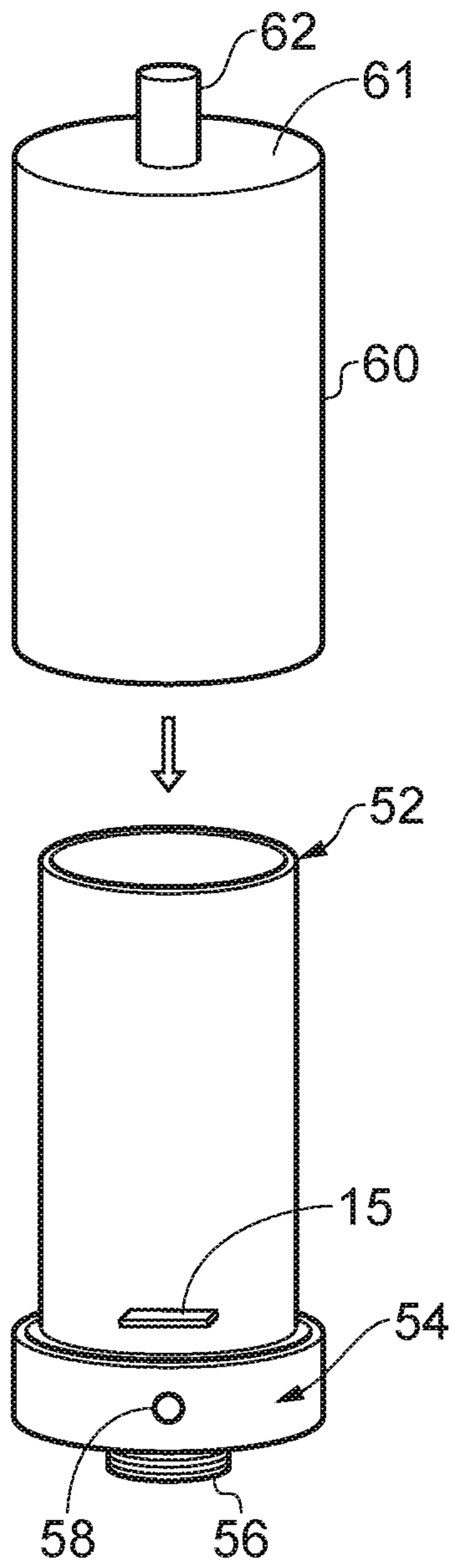

FIG. 6A

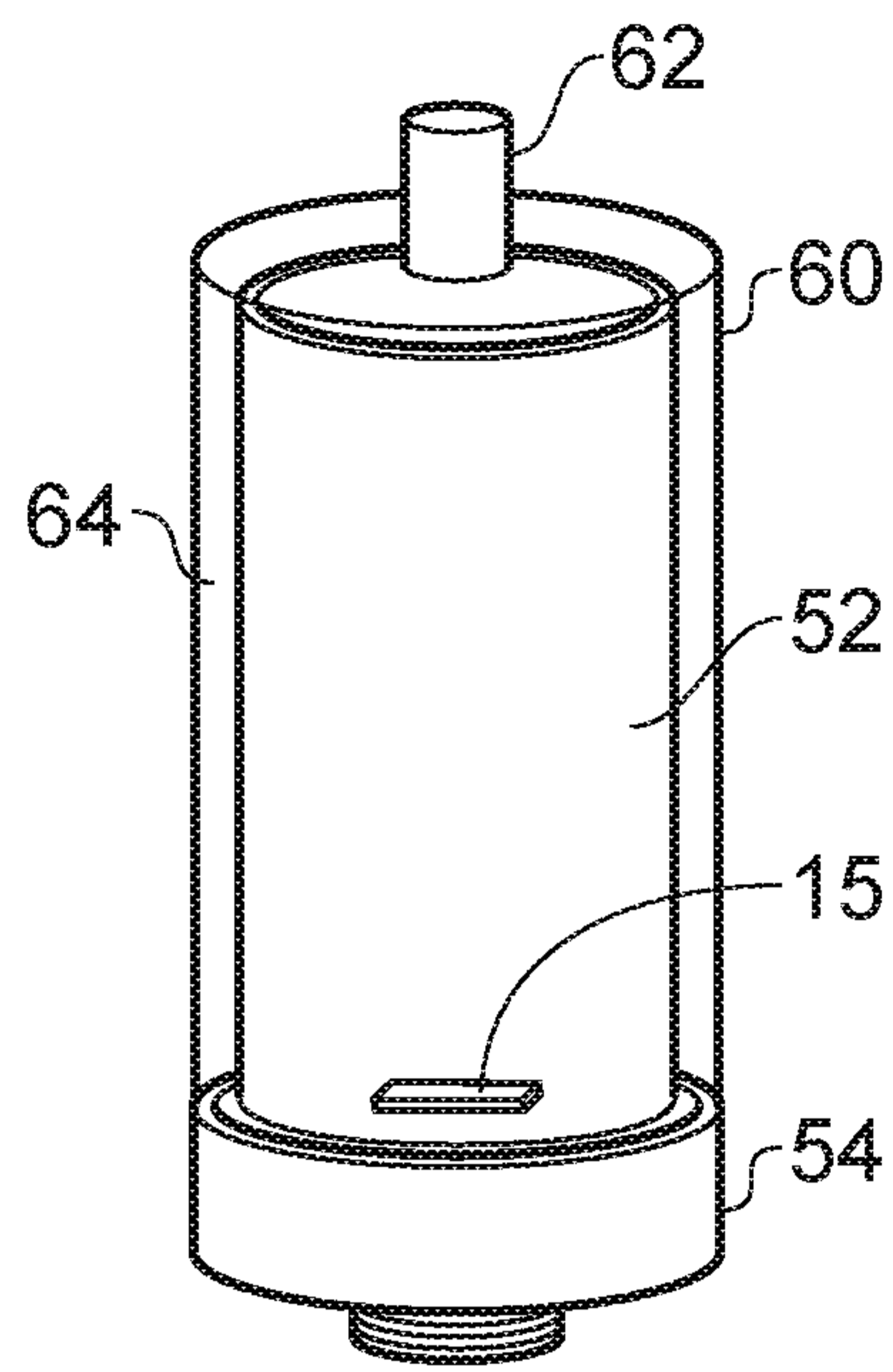

FIG. 6B

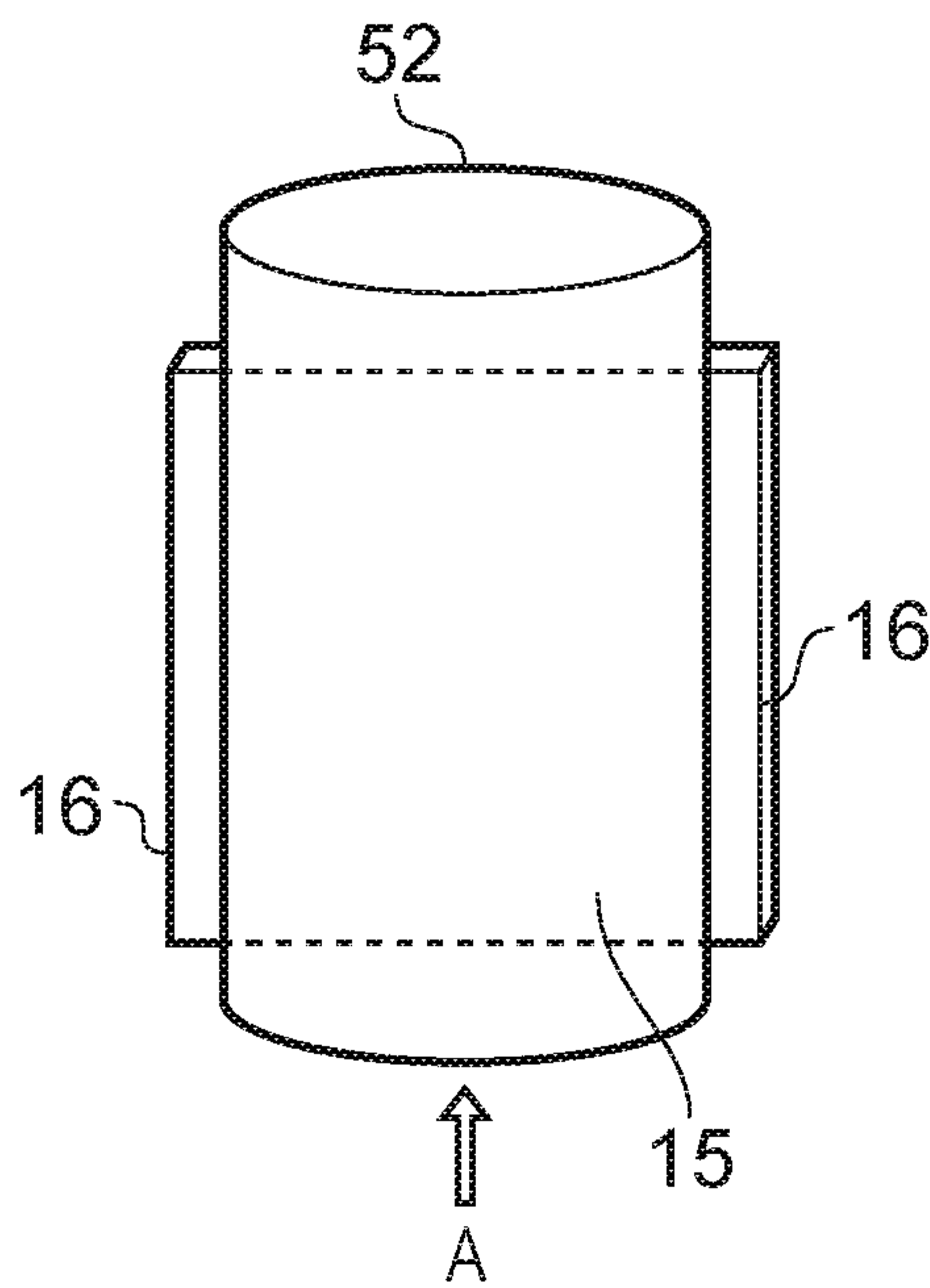

FIG. 7

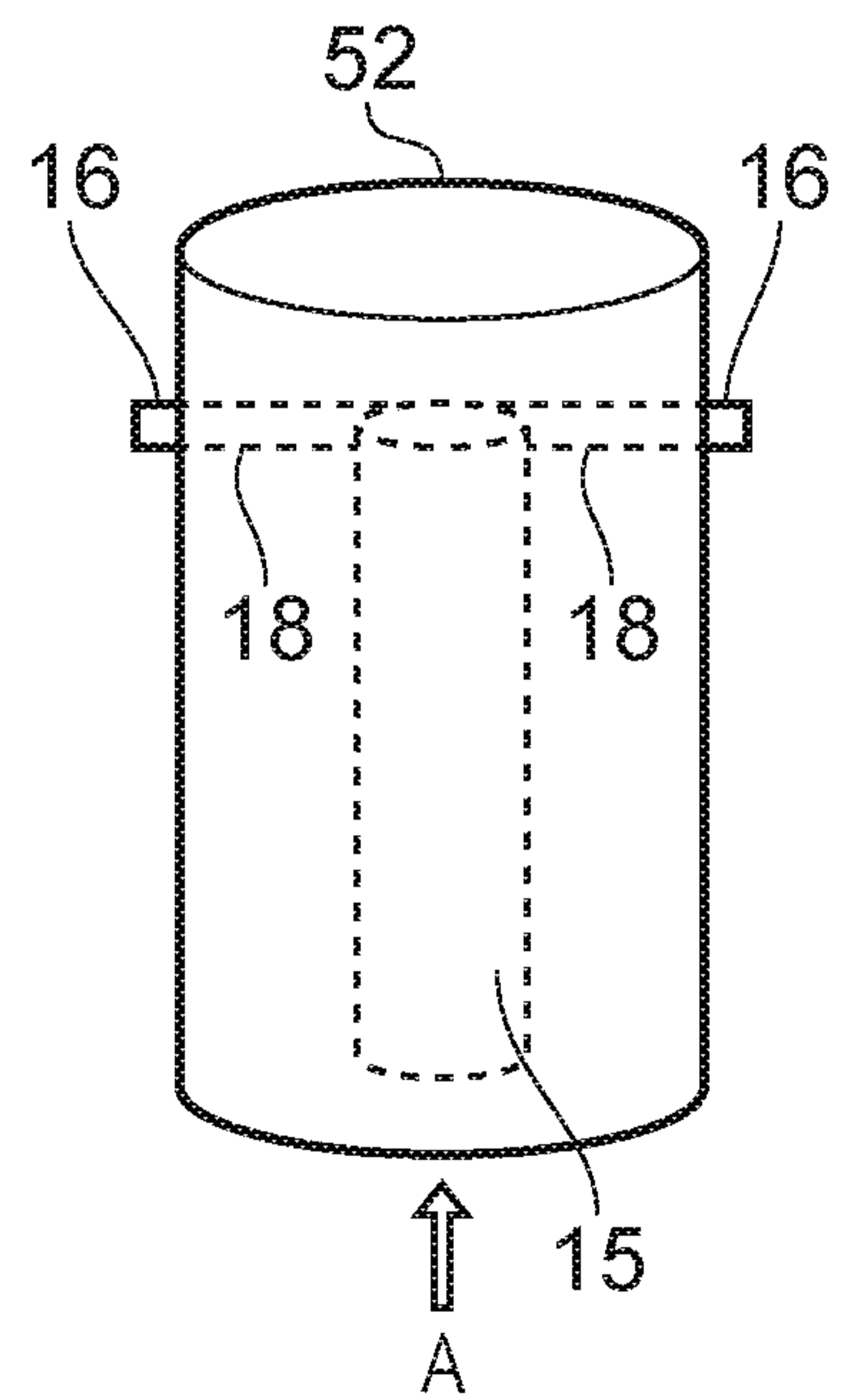

FIG. 8

