

(19)



(11)

**EP 4 003 541 B1**

(12)

**EUROPEAN PATENT SPECIFICATION**

(45) Date of publication and mention of the grant of the patent:  
**24.07.2024 Bulletin 2024/30**

(51) International Patent Classification (IPC):  
**A63B 21/005** <sup>(2006.01)</sup>    **A63B 21/078** <sup>(2006.01)</sup>  
**A63B 21/00** <sup>(2006.01)</sup>    **A63B 23/12** <sup>(2006.01)</sup>

(21) Application number: **21726191.6**

(52) Cooperative Patent Classification (CPC):  
**A63B 21/078; A63B 21/0058; A63B 21/0783;**  
**A63B 21/154; A63B 21/4035; A63B 21/4045;**  
**A63B 23/1209; A63B 2214/00; A63B 2220/805;**  
**A63B 2220/833**

(22) Date of filing: **23.04.2021**

(86) International application number:  
**PCT/IB2021/053364**

(87) International publication number:  
**WO 2021/214723 (28.10.2021 Gazette 2021/43)**

---

(54) **GYMNASTIC MACHINE FOR WEIGHTLIFTING**

GYMNASTIKMASCHINE ZUM GEWICHTHEBEN

MACHINE DE GYMNASTIQUE POUR HALTÉROPHILIE

(84) Designated Contracting States:  
**AL AT BE BG CH CY CZ DE DK EE ES FI FR GB**  
**GR HR HU IE IS IT LI LT LU LV MC MK MT NL NO**  
**PL PT RO RS SE SI SK SM TR**

(72) Inventor: **Cristofanelli, Stefano**  
**36015 Schio (VI) (IT)**

(30) Priority: **23.04.2020 IT 202000008707**

(74) Representative: **Bonini, Ercole**  
**Studio Bonini Srl**  
**Corso Fogazzaro, 8**  
**36100 Vicenza (IT)**

(43) Date of publication of application:  
**01.06.2022 Bulletin 2022/22**

(56) References cited:  
**WO-A1-2005/030341    KR-B1- 102 053 685**  
**US-A1- 2005 202 941    US-A1- 2020 023 227**  
**US-B2- 6 749 538**

(73) Proprietor: **Cristofanelli, Stefano**  
**36015 Schio (VI) (IT)**

**EP 4 003 541 B1**

---

Note: Within nine months of the publication of the mention of the grant of the European patent in the European Patent Bulletin, any person may give notice to the European Patent Office of opposition to that patent, in accordance with the Implementing Regulations. Notice of opposition shall not be deemed to have been filed until the opposition fee has been paid. (Art. 99(1) European Patent Convention).

## Description

**[0001]** The invention relates to a gymnastic machine for weightlifting.

**[0002]** Nowadays, in weightlifting, bodybuilding and fitness gyms in general, strength and hypertrophy training is carried out mainly using a barbell, i.e., a grip bar, normally made of steel, provided with load bodies at the opposite ends.

**[0003]** Today, the free barbell is the main equipment for athletic training and preparation in the weight room; the athlete applies the desired load to the ends of the barbell, secures it, using locking devices, and begins the performance of a predetermined exercise.

**[0004]** When using particularly high loads, the athlete needs external help from one or more wingmen, who must be immediately available in order to complete the exercise safely, since there are no safety devices that can intervene in the event of an injury to the athlete when he is lifting the barbell.

**[0005]** One of the main limitations of the training with barbells described above is therefore related to the fact that such a training cannot be carried out in total safety if not in the presence of particularly attentive wingmen prepared to intervene to support the athlete in any moment of need.

**[0006]** Another limitation of known type barbell training is the numerous downtimes required to replace or add new and/or different load bodies at the opposite ends of the grip bar.

**[0007]** A further limitation of barbell training is the fact that the physical performance of the athlete is not detectable with continuity and precision since the available parameters are only the weight of the barbell and the time of execution of the exercise. Document US2020/023227 A1 describes an exercise machine, having a cable that connects resistance device to moveable section and connects resistance device to first and second functional training devices,

**[0008]** The task of the present invention is to develop a gymnastic machine for weightlifting capable of obviating the aforementioned drawbacks and limitations of the known art.

**[0009]** In particular, one object of the invention is to develop a gymnastic machine that is safe and can be used by an athlete without any auxiliary wingmen being present when needed.

**[0010]** Another object of the invention is to develop a gymnastic machine that will allow eliminating the downtimes of replacing, removing or adding loads, which are typical actions of using the barbells known today.

**[0011]** Still, one object of the invention is to develop a gymnastic machine capable of continuously and accurately detecting the athlete's performance.

**[0012]** The above mentioned task and objects are achieved by a gymnastic machine for weightlifting according to claim 1 and the corresponding method claim 10.

**[0013]** Further characteristics of the gymnastic machine according to claim 1 are described in the dependent claims.

**[0014]** The aforesaid task and objects, together with the advantages that will be mentioned hereinafter, are indicated by the description of an embodiment of the invention, which is given by way of non-limiting example with reference to the attached drawings, where:

- Figure 1 represents a perspective view of a gymnastic machine according to the invention;
- Figure 2 represents another perspective view of the gymnastic machine of Figure 1;
- Figure 3 represents a sectional side view of the gymnastic machine according to the invention;
- Figure 4 represents a side view of the gymnastic machine according to the invention;
- Figure 5 represents a detail of the gymnastic machine according to the invention;
- Figure 6 represents a top view of the detail shown in Figure 5;
- Figure 7 represents a sectional view of another detail of the gymnastic machine according to the invention;
- Figure 8 represents a front view of the detail of Figure 7;
- Figure 9 represents an operating diagram of the gymnastic machine according to the invention;
- Figure 10 represents a schematic view of a variant embodiment of the invention.

**[0015]** With reference to the above-mentioned figures, a gymnastic machine for weightlifting according to the invention is shown as a whole with the number **10**.

**[0016]** Said gymnastic machine **10** comprises:

- a load-bearing frame **11**,
- two opposite first lateral guides **12** and **13**, upward-downward, developed according to a first direction **X1**,
- two first slides **14** and **15** each slidingly constrained on a corresponding first lateral guide **12** and **13**,
- two opposite second lateral guides **16** and **17**, developed according to a second direction **X2** transversal to the first direction **X1**, and each defined on board of one of the first slides **14** and **15**,
- two second slides **18** and **19** each slidingly constrained on a corresponding second lateral guide **16** and **17**,
- a lifting bar **20**, each of the ends **20a**, **20b** of said lifting bar **20** being constrained to a corresponding second slide **18** and **19**,
- motorised transmission means **21** configured to apply to the first slides **14** and **15** either an opposing force to an upward thrust force, or a downward traction force.

**[0017]** In the embodiment of the invention described herein by way of a non-limiting example of the invention

itself, the load-bearing frame **11** comprises a ground support base **40**, such as a quadrangular frame, within which a user is positioned.

**[0018]** Two opposite shoulders **41** and **42** supporting the first lateral guides **12** and **13** develop from the ground support base **40**.

**[0019]** In the present example embodiment, each of the shoulders **41** and **42** comprises two uprights **43** and **44** and an upper crosspiece **45**.

**[0020]** In the present example embodiment, the first direction **X1** is substantially vertical, i.e., unless unavoidable construction and installation tolerances.

**[0021]** The two opposite first lateral guides **12** and **13** each comprise two bars **46** and **47** respectively, which develop between the base **40** and an overlying crosspiece **45**.

**[0022]** The first lateral guides **12** and **13** are each located within the arc defined by the uprights **43** and **44** and the crosspiece **45**.

**[0023]** The two first slides **14** and **15**, as clearly shown in the side view of Figure 4 and the section of Figure 5, each comprise:

- two first slider sleeves **48** and **49**,
- at least one transverse element, for example two transverse elements **50** and **51**, rigidly connecting the two slider sleeves **48** and **49**.

**[0024]** The first slider sleeves **48** and **49** slide on the respective bars **46** and **47** of the first lateral guides **12** and **13** by interposition of one or more friction reducing devices **52** and **53**, for example one or more linear recirculating ball bearings, highlighted in Figure 5.

**[0025]** In the present example embodiment, the second lateral guides **16** and **17** each comprise a guide bar **54**, clearly visible in Figures 3, 4 and 5, fixed by brackets **55** between the sleeves **48** and **49** of the respective first slide **14** and **15** to which they belong.

**[0026]** The guide bar **54** is also positioned between the two transverse elements **50** and **51** of the first slide **14** and **15**.

**[0027]** The two second slides **18** and **19** each comprise, as clearly shown for the second slide **18** in Figures 7 and 8, a second slider sleeve **58** to which a collar **59** is fixed, configured for the constraint with an end **20a** or **20b** of the lifting bar **20**.

**[0028]** The collar **59** develops according to a direction orthogonal to the direction of development, and translation, of the second slider sleeve **58**.

**[0029]** The second slider sleeve **58** slides on the respective guide bar **54** of the corresponding second lateral guide **16** and **17** by interposition of one or more friction reducing devices **60** and **61**, for example one or more linear recirculating ball bearings, highlighted in Figure 7.

**[0030]** The lifting bar **20** is constrained at the ends **20a** and **20b** to a corresponding collar **59** of a second slide **18** and **19** by friction reducing devices, for example rolling bearings **62**.

**[0031]** Such friction reducing devices are configured to allow the ends **20a** and **20b** of the lifting bar **20** to rotate by an angle of less than 10° about the axis **X2** of the guide bar **54**; this possibility to rotate, although modest, allows the athlete to perform his exercises even in a slightly asymmetrical manner.

**[0032]** The motorised transmission means **21** comprise, in the present example embodiment, two electric motors **22** and **23**.

**[0033]** Each of the two electric motors **22** and **23** is configured to actuate a corresponding longitudinally developed flexible element **24** and **25**.

**[0034]** In a variant, not illustrated for simplicity but intended to be included in the present invention, the gymnastic machine according to the invention comprises a single electric motor configured to actuate both longitudinally developed flexible elements.

**[0035]** Such longitudinally developed flexible elements **24** and **25** may comprise a belt, a chain, a rope or other similar and equivalent elements.

**[0036]** In the present example embodiment, the longitudinally developed flexible elements **24** and **25** each comprise a toothed belt.

**[0037]** The motorised transmission means **21** comprise, for each longitudinally developed flexible element **24** and **25**, as schematised in the section of Figure 3:

- at least one lower pulley, for example a lower pulley **26**, configured and positioned to deflect a longitudinally developed flexible element **24** and **25** coming from an electric motor **22** and **23** towards a lower portion **14a** and **15a** of a said first slide **14** and **15**,
- at least one upper pulley, for example two respective upper pulleys **28** and **29**; said upper pulleys are configured and positioned to deflect a corresponding longitudinally developed flexible element **24** and **25** towards an upper portion **14b** and **15b** of a first slide **14** and **15**,
- a drive pulley **27**, fixed to the corresponding electric motor shaft **22** and **23**.

**[0038]** Each of the longitudinally developed flexible elements **24** and **25**, or, henceforth, the belts **24** and **25** for convenience of exposition, defines a circuit that develops starting from a lower part **14a** and **15a** of a first slide **14** and **15**, turns around the lower pulley **26**, the drive pulley **27**, the upper pulleys **28** and **29**, up to the upper portion **14b** and **15b** of the same first slide.

**[0039]** Thus, each electric motor **22** and **23**, with the corresponding longitudinally developed element **24** and **25** and the corresponding first slide **14** and **15**, creates a movement circuit of a first slide **14** that is independent of the other movement circuit of the other first slide **15**.

**[0040]** The fixing of a belt **24** and **25** to the respective first slide **14** and **15** is made by fixing means to be understood as being of a type known in itself.

**[0041]** Such motorised transmission means **21** therefore comprise two symmetrical assemblies each com-

prising pulleys **26**, **27**, **28** and **29** and a toothed belt **24** or **25**.

**[0042]** Each assembly is enslaved to a first, vertical slide **14** and **15**, and transmits a vertical linear translatory motion to said first slide **14** and **15**.

**[0043]** The pulleys act as deflectors that allow the respective belt **24** and **25** to bypass the load-bearing frame **11** and be driven by the electric motor **22** and **23** through the drive pulley **27**.

**[0044]** Each longitudinally developed flexible element **24**, **25**, in this case each belt **24** and **25**, has a respective safety counterweight **35**.

**[0045]** Such a counterweight **35** is positioned, for example, on an upward-downward section of each belt **24** and **25**.

**[0046]** This counterweight **35** is intended to be able to be positioned also in another position.

**[0047]** Said counterweight **35** is configured and positioned so as to nullify, with electric motors **22** and **23** switched off, the weight contribution given by the first slides **14** and **15** and by the second slides **18** and **19**.

**[0048]** In this way, with switched off or faulty electric motors **22** and **23**, and brakes of the electric motors not in operation, no load is placed on the user athlete and his safety is ensured.

**[0049]** The counterweight **35** is obviously placed on a section **24a** and **25a** of the longitudinally developed flexible element **24** and **25**, i.e., of the belt **24** and **25**, where the first slide **14** and **15** is not present.

**[0050]** In the present example embodiment, the counterweight **35** is fixed to the belt **24** and **25** in the section **24a** and **25a** between the drive pulley **27** and the first upper pulley **28**.

**[0051]** The gymnastic machine **10** comprises an electronic control unit **90**, configured to control and manage the operation of said motorised transmission means **21**. Such an electronic control unit **90** is schematically illustrated by a box in Figure 1.

**[0052]** The electric motors **22** and **23** are preferably, but not exclusively, of the brushless type.

**[0053]** Said electric motors **22** and **23** may be associated with a corresponding torque reducer, to be understood, of course, as a known type in itself. The reducer can be two-stage or three-stage.

**[0054]** In particular, each of the electric motors **22** and **23** comprises an encoder and an integrated brake.

**[0055]** The gymnastic machine **10** may also comprise an additional speed transducer, for each of the first slides **14** and **15**.

**[0056]** This additional transducer is capable of directly measuring the speed of the corresponding first slide **14** and **15**.

**[0057]** The encoder on board of the electric motor **22** and **23** detects the speed of the first slide **14** and **15** indirectly, based on the rotational speed of the encoder disc itself.

**[0058]** This additional speed transducer is installed on board of the machine and connected to the electronic

control unit **90**.

**[0059]** The gymnastic machine **10** advantageously also comprises a signalling device **85**, schematised in Figures 1 and 8, configured to signal the grasping and release of said lifting bar **20** by a user, which signalling device is connected to said electronic control unit **90**.

**[0060]** In the present example embodiment of the invention, which is not limiting thereto, such a signalling device **85** comprises a pair, or alternatively two pairs, of elements, an emitter and a receiver, e.g., photocells, located at opposite ends **20a** and **20b** of the lifting bar **20**; for example, an emitting photocell is positioned at a first end **20a** and an opposite receiving photocell is positioned at the opposite end **20b**, or vice versa.

**[0061]** The emitter and the receiver are positioned on the lifting bar **20**, in a position to detect the presence of a hand on the same lifting bar **20**.

**[0062]** In an alternative embodiment of the invention, schematised in Figure 10, the signalling device **185** comprises at least one pair of elements, an emitter **185a** and a receiver **185b**, positioned facing a grasping area of the lifting bar **20** so as to detect the presence or absence of a single hand of the athlete on the lifting bar **20**.

**[0063]** Still in particular, the signalling device **185** comprises two pairs of elements, a first pair of emitter **185a** and receiver **185b** elements and a second pair of emitter **185c** and receiver **185d** elements, each pair of elements being positioned to detect the presence or absence of a corresponding athlete's hand on the lifting bar.

**[0064]** This alternative solution is particularly effective and is insensitive to any bending of the lifting bar **20**.

**[0065]** Preferably, and advantageously, the emitter and receiver elements are mounted on the lifting bar **20** with position adjustment means along the same lifting bar **20**.

**[0066]** Such means, which are to be understood to be of a known type, may be a band of plastic material, or a metal sleeve with means for clinging to the bar, or other similar and equivalent reversible fixing means.

**[0067]** The possibility of moving the emitter and receiver along the lifting bar **20** makes the signalling device **85** and **185** particularly versatile and easily adaptable to the specific ergonomics of the athlete.

**[0068]** Said signalling device **85** is configured to operate so that the signal, which passes just above the lifting bar, preferably flush with the surface of the lifting bar **20** itself, is interrupted by the athlete's hand being closed.

**[0069]** The signal remains interrupted until the user athlete opens one hand, or both hands.

**[0070]** When the user athlete releases his grip, for whatever reason, when he opens his hands the signal between emitter and receiver becomes active again, signalling the interruption of the use of the gymnastic machine **10**.

**[0071]** Preferably, all electronic components are of the safety-integrated type.

**[0072]** The signalling device **85** is also connected to the electronic control unit **90**. The electronic control unit

**90** comprises, for example, a PLC.

**[0073]** Said electronic control unit **90** is interconnected to the encoders of the electric motors **22** and **23** and by means of said encoders receives signals such as to be able to calculate position, speed and acceleration of the lifting bar **20**.

**[0074]** The electronic control unit **90** comprises a man-machine interface system, for example a panel with a touch screen; via the screen, the user athlete intervenes in the management of the motorised transmission means **21**, determining the load for the physical weightlifting exercise.

**[0075]** Through the same screen, the user athlete has the possibility of viewing and extracting the statistics of his training.

**[0076]** The beginning and the end of the execution of one or more exercises are signalled through the hands-on type signalling device **85**, whereby the closing of one hand around the lifting bar signals the start of the execution of an exercise, while the opening, whether voluntary or involuntary, of both hands forces the stop of the exercise machine **10**.

**[0077]** In particular, therefore, the electronic control unit **90** allows the gymnastic machine **10**, through the action of the electric motors **22** and **23**, to replicate the action of the force of gravity on the lifting bar **20**, whose load is decided and set by the user athlete through the same electronic control unit **90**.

**[0078]** The electronic control unit **90** is configured, and therefore programmed, in such a way that, when the gymnastic machine **10** is switched on, the initial state of the lifting bar **20**, i.e., its position in particular, is first checked.

**[0079]** Once the user athlete has selected a workload, the lifting bar **20** is positioned, by slow speed movements, at a fixed height above the ground.

**[0080]** The user athlete positions himself inside the frame **11** of the gymnastic machine **10**, ready to perform his exercise; the user athlete signals his presence by means of the hands-on signalling device **85** and performs, under a minimum load, two repetitions; in this way, the machine records the maximum and minimum heights that the barbell reaches during the real exercise.

**[0081]** After the execution of the repetitions under minimum load there is the actual execution of the exercise.

**[0082]** Again through the hands-on signalling device **85**, the athlete requests the application of the workload, and starts training.

**[0083]** The electronic control unit **90** detects position, speed and acceleration of the lifting bar **20** in real time, so as to perform the following operations:

- recording and analysis of the athlete's performance;
- detection of possible fatigue of the athlete, to which the gymnastic machine **10** shall compensate with appropriate and calibrated load reductions, in order to allow the safe completion of the exercise;
- detection of any dangerous situations, e.g., collision between the lifting bar and the athlete, fall of the lifting

bar, loss of consciousness of the athlete.

**[0084]** The end of the exercise is signalled by the opening of the athlete's hands, otherwise always gripping the lifting bar **20**.

**[0085]** The electric motors **22** and **23**, by delivering torque, tension the belts **24** and **25** which, in turn, exert a load on the first vertical slides **14** and **15**. This is the athlete's training load.

**[0086]** The electric motors **22** and **23**, operating according to the signals imposed by the electronic control unit **90**, regulate said load so as to:

- reproduce the contributions of inertia, i.e., the increase and reduction of load that the athlete perceives during the accelerating and decelerating steps of the movement;
- adjust the load impressed, i.e., the torque delivered, in the event of athlete fatigue; this step is optional, chosen by the athlete, and can be selected via the man-machine interface, i.e., through the touch screen of the electronic control unit **90**;
- abruptly stop the lifting bar **20** in the event of a danger signal.

**[0087]** The electronic control unit **90** detects the presence of the athlete through the hands-on signalling device **85**, and also detects the position, the speed and the acceleration of each of the electric motors **22** and **23** through their respective on-board encoders.

**[0088]** These signals are recorded and stored by the electronic control unit **90** during the entire execution of the exercise.

**[0089]** The electronic control unit **90** is configured in such a way as to compare, between one repetition and the previous ones, position and speed in order to assess whether the athlete is getting tired, and therefore whether he will be able to complete the exercise independently; if fatigue is detected, the electronic control unit **90** commands the electric motors **22** and **23** to reduce the load.

**[0090]** To ensure the safety of the athlete, the electronic control unit **90** is configured to check at all times:

- the signal of the signalling device **85**, and if the signal is cancelled it means that the athlete has lost the lifting bar **20** or has fainted;
- the position of the lifting bar **20**, so that if it drops below the bottom dead centre BDC it means that it is crushing the athlete's body;
- the speed of the lifting bar **20**, so that if it is high near the bottom dead centre BDC it means that the athlete will not be able to avoid a collision with the same lifting bar **20**;
- and the downward acceleration of the lifting bar **20**, so that if it goes beyond a certain fraction of g, whereby g is intended to be the gravitational acceleration, it means that the barbell is falling free.

**[0091]** A method of operation of the gymnastic machine **10** according to the invention is described below and is schematised in Figure 9.

**[0092]** This method of operation includes the following operating steps:

- starting the machine, indicated in Figure 9 with block **100**;
- a preparation step, comprising the following sequence of actions **200**:
  - positioning of the barbell, wherein the barbell is brought to a height set by the athlete; the data of the starting height is entered by means of the electronic control unit **90** by the user athlete; this positioning is carried out by the gymnastic machine **10** at low speed; moreover, the athlete selects the type of exercise and the workload; this step is schematised by block **101**;
  - actuating the hands-on signalling device **85**; in this step the user athlete, ready to perform the exercise, grasps the lifting bar **20**, thus activating the signalling device **85** which signals the presence of a hand on the lifting bar **20**, enabling the user athlete to perform the exercise; this step is schematised by block **102**;
  - performing at least two, preferably three, unloaded repetitions of the movements of the exercise by the user athlete, in order to teach, or have the electronic control unit **90** memorize, the position of the top dead centre TDC and the bottom dead centre BDC of the stroke of the lifting bar **20**, that is, the points of maximum and minimum ground clearance that the lifting bar **20** is expected to reach during the performance of the exercise; this step is schematised with block **103**;
  - reading of the values; the electronic control unit **90** detects the activation of the hands-on signalling device **85**, indicated by the symbol 'h', the position x, the speed x' and the acceleration x''; this step is schematised by the block **104**;
  - analysis of the repetitions and check that the repetitions performed are regular, that is that the repetitions have similar BDC and similar TDC; this step is schematised by the block **105**;
  - if the preceding analysis step detects the regularity of the repetitions, then the user athlete releases the lifting bar **20**, allowing the signal to pass in the signalling device **85**; this step of release of the lifting bar **20** is schematised by the block **107**; this control operation is schematised by the control block **106**;
  - if the previous analysis step does not detect the regularity of the repetitions, then the user athlete performs the repetitions as per block **103** again; this control operation is schematised by the control block **106**;

- after release of the lifting bar **20**, there is positioning of the lifting bar **20** itself at the athlete's choice at the top or bottom dead centre; this step is schematised by the block **108**.

**[0093]** With said step **108**, the preparation step **200** ends.

**[0094]** The preparation step **200** is followed by the training step **300**.

**[0095]** Said training step **300** comprises the following operating steps:

- actuating the hands-on signalling device **85**; in this step the user athlete, ready to perform the exercise, grasps the lifting bar **20**, interrupting the signal between emitter and receiver and thus activating the signalling device **85**, which signals the presence of a hand on the lifting bar **20**, enabling the user athlete to perform the exercise; this step is schematised by the block **109**;
- load application, that is, the electric motors **22** and **23** deliver torque and reach the training load, including inertial contributions; this step is schematised by the block **110**;
- reading the parameters of position x, speed x', acceleration x'', and time t, following activation of the gymnastic machine **10** through the hands-on signalling device **85**, i.e. the electronic control unit **90** detects the interruption of the signal between the emitter and the receiver of the signalling device **85**, indicated by the symbol h, and also detects the position x, speed x' and acceleration x'' of the lifting bar **20**, and the time t of execution of the exercise; this step is schematised by the block **111**;
- data saving, that is the electronic control unit **90** performs information storage; this step is schematised by the block **112**.

**[0096]** The training step **300** comprises a cycle of safety operations **400** always iterated until the stop step **116** of conclusion of the exercise.

**[0097]** This cycle of safety operations **400** comprises the following operating steps:

- check of the presence of at least one hand of the athlete on the lifting bar **20** by means of the signalling device **85**; this step is schematised by the control block **113**;
- if the signalling device **85** signals that there are no hands on the lifting bar **20**, then the data saving is carried out, schematised by the block **114**, and the machine is stopped, schematised by the block **116**;
- if the signalling device **85** signals the presence of hands on the lifting bar **20**, then it is checked whether the height x of the lifting bar is above or below a threshold value Xs of crushing the athlete's body; this step is schematised by the control block **115**;
- if the height x of the lifting bar is below a threshold

value  $X_s$  of crushing the athlete's body, then data saving is carried out, see block **114**, and the exercise is stopped, see block **116**;

- if the height  $x$  of the lifting bar **20** is above the threshold value  $X_s$ , and therefore the exercise is proceeding within the predefined safety limits, then it is checked whether the downward speed  $x'$  of the lifting bar **20** is greater than a threshold value  $X_s'$ ; this step is schematised by the control block **117**;
- if the downward speed  $x'$  is greater than said threshold value  $X_s'$ , then the data saving, see block **114**, and the exercise stop, see block **116**, are performed;
- if the downward speed  $x'$  is less than said threshold value  $X_s'$ , and therefore the exercise is proceeding within the predefined safety limits, then it is checked if the downward acceleration  $x''$  of the lifting bar **20** is greater than a threshold value  $X_s''$  of fall of the lifting bar **20**; this step is schematised by the control block **118**;
- if the downward acceleration  $x''$  is greater than said threshold value  $X_s''$ , then data saving, see block **114**, and exercise stop, see block **116**, are performed;
- if the downward acceleration  $x''$  is less than said threshold value  $X_s''$ , then the exercise continues from the load application step, block **110**, or an auxiliary step **500** of possible reduction of the exercise load intervenes.

**[0098]** Said auxiliary step **500** comprises the following operating steps:

- check of the position  $x$  of the lifting bar **20** with respect to the bottom dead centre position XBDC, schematised by the control block **119**;
- if the position  $x$  is above XBDC, then it is checked if the speed  $x'$  of the lifting bar **20** falls below a threshold value  $X_s'$  close to zero before the TDC, schematised by the control block **120**;
- if the position  $x$  does not return above XBDC, then it is checked whether the time  $t$  of stay at the BDC is greater than a threshold value TBDC, i.e., it is checked whether the athlete succeeds or fails in bringing the load back upwards; this step is schematised by the control block **121**;
- if the speed  $x'$  of the lifting bar **20** falls below a threshold value  $X_s'$  close to zero before the TDC, then a load reduction, schematised by the block **122**, intervenes;
- if the stay time  $t$  at the BDC is greater than a threshold value TBDC, then a load reduction intervenes, see block **122**.

**[0099]** When the load is reduced, the training step **300** resumes from the load application step, block **110**.

**[0100]** The electronic control unit **90** is therefore configured to reduce the load under predetermined circumstances and to interrupt the exercise, while storing the exercise data in each case.

**[0101]** The reduction of the load can have a limited duration, in fact very often the athlete, after a minimum help, succeeds in resuming independently the execution of the exercise, or it can be permanent, for example, in particular, if the reduction of the load has already occurred several times during the same exercise.

**[0102]** It has in practice been established that the invention achieves the intended task and objects.

**[0103]** In particular, with the invention, a safe gymnastic machine has been developed which can be used by an athlete without the presence of auxiliary wingmen in case of need, since the same motorised transmission means **21**, governed by the electronic control unit **90**, apply the load to the lifting bar **20** and retain the same in case of injury or fatigue of the athlete.

**[0104]** Furthermore, with the invention a gymnastic machine has been developed which allows to eliminate the downtimes of replacement, removal or addition of loads, actions typical of the use of the barbells known today, being such gymnastic machine devoid of masses to be replaced, added or removed.

**[0105]** In addition, with the invention a gymnastic machine capable of continuously and accurately detecting the athlete's performance has been devised.

**[0106]** In practice, any components and materials can be used, as well as any dimensions and contingent shapes, according to requirements and the prior art, as long as they are compatible with the specific use.

**[0107]** If the characteristics and techniques mentioned in any claim are followed by reference signs, these reference signs are to be intended for the sole purpose of increasing the intelligibility of the claims and, consequently, such reference signs have no limiting effect on the interpretation of each element identified by way of example from these reference signs.

## Claims

1. Gymnastic machine for weightlifting (10), comprising:

- a load-bearing frame (11),
- two opposite first lateral guides (12, 13), extending in a first vertical direction ( $X_1$ ),
- two first slides (14, 15) each slidingly constrained on a corresponding first lateral guide (12, 13),
- two opposite second lateral guides (16, 17), extending in a second direction ( $X_2$ ) transversal to said first vertical direction ( $X_1$ ), and each defined on board of one of said first slides (14, 15),
- two second slides (18, 19) each slidingly constrained on a corresponding second lateral guide (16, 17),
- a lifting bar (20), each of the ends (20a, 20b) of said lifting bar (20) being constrained to a corresponding second slide (18, 19),

- motorised transmission means (21) configured to apply on said first slides (14, 15) either an opposing force to an upward thrust force, or a downward traction force,  
**characterized in that** said motorised transmission means (21) comprise two electric motors (22, 23) each of which is configured to actuate a corresponding longitudinally developed flexible element (24, 25),  
each longitudinally developed flexible element (24, 25) being connected at a first end to the lower part (14a, 15a) of a first slide (14, 15) of the two first slides, and at the second opposite end being connected to the upper part (14b, 15b) of the same first slide (14, 15),  
said motorised transmission means (21) comprising, for each longitudinally developed flexible element (24, 25):
- at least one lower pulley (26) configured and positioned to deflect the longitudinally developed flexible element (24, 25) coming from the said electric motor (22, 23) towards the said lower part (14a, 15a) of the said first slide (14, 15),
  - at least one upper pulley (28, 29, 30, 31) configured and positioned to deflect the said longitudinally developed flexible element (24, 25) towards an upper part (14b, 15b) of the said first slide (14, 15).
2. Gymnastic machine according to claim 1, **characterized in that** it further comprises an additional speed transducer, for each of the first slides (14, 15).
  3. Gymnastic machine according to one or more of the preceding claims, **characterised by** comprising an electronic unit (90) for controlling the operation of said motorised transmission means (21).
  4. Gymnastic machine according to one or more of the preceding claims, **characterized in that** said electric motors (22, 23) are of the brushless type.
  5. Gymnastic machine according to one or more of the preceding claims, **characterized in that** each of said electric motors (22, 23) comprises an encoder and an integrated brake.
  6. Gymnastic machine according to one or more of the preceding claims, **characterized in that** said longitudinally developed flexible elements (24, 25) comprise a belt, a chain, a rope or other similar and equivalent elements.
  7. Gymnastic machine according to one or more of the preceding claims, **characterised in that** it comprises a device (85) for signalling the grasping and release of said lifting bar (20) by a user, said signalling device (85) being connected to said electronic control unit (90).
  8. Gymnastic machine according to one or more of the preceding claims, **characterized in that** each longitudinally developed flexible element (24, 25) has a safety counterweight (35).
  9. Gymnastic machine according to claim 3, **characterized in that** said electronic control unit (90) is configured to check at all times:
    - the signal of said signalling device (85),
    - the position of said lifting bar (20),
    - the speed of said lifting bar (20),
    - and the downward acceleration of said lifting bar (20).
  10. Method of operation of a gymnastic machine (10) according to one or more of claims 1 to 9, **characterized in that** it comprises the following operating steps:
    - starting the machine (100);
    - a preparation step, comprising the following sequence of actions (200):
      - positioning of the barbell (101), wherein the barbell, that is said lifting bar (20), is brought to a height set by the athlete;
      - actuating (102) the hands-on signalling device (85), which signals the presence of a hand on the lifting bar (20), enabling the user athlete to perform the exercise;
      - performing at least two unloaded repetitions (103) of the movements of the exercise by the user athlete, in order to teach, or have the electronic control unit (90) memorize, the position of the top dead centre (TDC) and of the bottom dead centre (BDC) of the stroke of the lifting bar (20), that is, the maximum and minimum ground clearance points that the lifting bar (20) is expected to reach during the exercise;
      - reading of the values (104) by the electronic control unit (90), which detects the activation (h) of the hands-on signalling device (85), the position (x), the speed (x') and the acceleration (x'') of said lifting bar (20);
      - analysis of the repetitions and check that the repetitions performed are regular (105), that is that the repetitions have similar bottom dead centres (BDC) and similar top dead centres (TDC);
      - if the previous analysis step (105) detects regularity of the repetitions (106), then the user athlete releases (107) the lifting bar

- (20), allowing the signal to pass in the signalling device (85);
- if the previous analysis step (105) does not detect the regularity of the repetitions (106), then the user athlete performs the repetitions again (103);
  - after release of the lifting bar (20), there is positioning (108) of the lifting bar (20) at the top dead centre (TDC) or bottom dead centre (BDC).

11. Method according to claim 10, **characterized in that** said preparation step (200) is followed by a training step (300), said training step (300) comprising the following operating steps:

- actuating (109) the hands-on signalling device (85);
- load application (110), that is, the electric motors (22, 23) deliver torque and reach the training load;
- reading (111) of the parameters of position (x), speed (x'), acceleration (x'') and time (t), following the activation of the gymnastic machine (10) by means of the hands-on signalling device (85), said electronic control unit (90) detecting the interruption of the signal between emitter and receiver of the signalling device (85), and detects the position (x), speed (x') and acceleration (x'') of said lifting bar (20) and the time (t) of execution of the exercise;
- data saving (112), that is, the electronic control unit (90) performs information storage.

12. Method according to the preceding claim, **characterized in that** said training step (300) comprises a cycle of safety operations (400) always iterated until a stop step (116) of conclusion of the exercise.

13. Method according to the preceding claim, **characterized in that** said cycle of safety operations (400) comprises the following operating steps:

- check (113) of the presence of at least one of the athlete's hands on the lifting bar (20) by means of said signalling device (85);
- if the signalling device (85) signals that there are no hands on the lifting bar (20), then data saving (114) is carried out and the machine is stopped (116);
- if the signalling device (85) signals the presence of hands on the lifting bar (20), then it is checked whether the height (x) of the lifting bar (20) is above or below a threshold value (Xs) of crushing the athlete's body (115);
- if the height (x) of the lifting bar (20) is below a threshold value (Xs) of crushing the athlete's body, then data saving (114) and exercise stop

(116) are performed;

- if the height (x) of the lifting bar (20) is above the threshold value (Xs), and therefore the exercise is proceeding within the predefined safety limits, then it is checked (117) if the downward speed (x') of the lifting bar (20) is greater than a threshold value (Xs');
- if the downward speed (x') is greater than said threshold value (Xs'), then data saving (114) and exercise stop (116) are performed;
- if the downward speed (x') is less than said threshold value (Xs'), and therefore the exercise is proceeding within the predefined safety limits, then it is checked (118) if the downward acceleration (x'') of the lifting bar (20) is greater than a threshold value (Xs'') of fall of the lifting bar (20);
- if the downward acceleration (x'') is greater than said threshold value (Xs''), then data saving (114) and exercise stop (116) are performed;
- if the downward acceleration (x'') is less than said threshold value (Xs''), then the exercise continues with a load application step (110), or an auxiliary step (500) of possible reduction of the exercise load intervenes.

## Patentansprüche

1. Turngerät zum Gewichtheben (10), umfassend:

- einen tragenden Rahmen (11),
  - zwei gegenüberliegende erste seitliche Führungen (12, 13), die sich in erster vertikaler Richtung (X1) erstrecken,
  - zwei erste Schlitten (14, 15), die jeweils an einer entsprechenden ersten seitlichen Führung (12, 13) gleitend festgespannt sind,
  - zwei gegenüberliegende zweite seitliche Führungen (16, 17), die sich in einer zweiten Richtung (X2) quer zur ersten vertikalen Richtung (X1) erstrecken und jeweils an Bord eines der ersten Schlitten (14, 15) definiert sind,
  - zwei zweite Schlitten (18, 19), die jeweils an einer entsprechenden zweiten seitlichen Führung (16, 17) gleitend festgespannt sind,
  - eine Hebestange (20), wobei jedes der Enden (20a, 20b) der Hebestange (20) an einen entsprechenden zweiten Schlitten (18, 19) festgespannt ist,
  - motorisierte Übertragungsmittel (21), die so konfiguriert sind, dass sie auf die ersten Schlitten (14, 15) entweder eine Gegenkraft zu einer Aufwärtsschubkraft oder eine Abwärtszugkraft aufbringen,
- dadurch gekennzeichnet, dass** die motorisierten Übertragungsmittel (21) zwei Elektromotoren (22, 23) umfassen, von denen jeder dazu

- konfiguriert ist, ein entsprechendes in Längsrichtung entwickeltes flexibles Element (24, 25) zu betätigen, wobei jedes in Längsrichtung entwickelte flexible Element (24, 25) an einem ersten Ende mit dem unteren Teil (14a, 15a) eines ersten Schlittens (14, 15) der zwei ersten Schlitten verbunden ist und an dem zweiten gegenüberliegenden Ende mit dem oberen Teil (14b, 15b) desselben ersten Schlittens (14, 15) verbunden ist, wobei die motorisierten Übertragungsmittel (21) für jedes in Längsrichtung entwickelte flexible Element (24, 25) umfassen:
- mindestens eine untere Riemenscheibe (26), die so konfiguriert und positioniert ist, dass sie das in Längsrichtung entwickelte flexible Element (24, 25), das von dem Elektromotor (22, 23) stammt, in Richtung des unteren Teils (14a, 15a) des ersten Schlittens (14, 15) ablenkt,
  - mindestens eine obere Riemenscheibe (28, 29, 30, 31), die so konfiguriert und positioniert ist, dass sie das in Längsrichtung entwickelte flexible Element (24, 25) in Richtung eines oberen Teils (14b, 15b) des ersten Schlittens (14, 15) ablenkt.
2. Turngerät nach Anspruch 1, **dadurch gekennzeichnet, dass** es ferner einen zusätzlichen Geschwindigkeitsgeber für jeden der ersten Schlitten (14, 15) umfasst.
  3. Turngerät nach einem oder mehreren der vorhergehenden Ansprüche, **dadurch gekennzeichnet, dass** es eine elektronische Einheit (90) zum Steuern des Betriebs der motorisierten Übertragungsmittel (21) umfasst.
  4. Turngerät nach einem oder mehreren der vorhergehenden Ansprüche, **dadurch gekennzeichnet, dass** die Elektromotoren (22, 23) vom bürstenlosen Typ sind.
  5. Turngerät nach einem oder mehreren der vorhergehenden Ansprüche, **dadurch gekennzeichnet, dass** jeder der Elektromotoren (22, 23) einen Encoder und eine integrierte Bremse umfasst.
  6. Turngerät nach einem oder mehreren der vorhergehenden Ansprüche, **dadurch gekennzeichnet, dass** die in Längsrichtung entwickelten flexiblen Elemente (24, 25) einen Riemen, eine Kette, ein Seil oder andere ähnliche und gleichwertige Elemente umfassen.
  7. Turngerät nach einem oder mehreren der vorhergehenden Ansprüche, **dadurch gekennzeichnet, dass** es eine Vorrichtung (85) umfasst, um zu signalisieren, dass die Hebestange (20) durch einen Benutzer ergriffen und losgelassen wurde, wobei die Signalvorrichtung (85) mit der elektronischen Steuereinheit (90) verbunden ist.
  8. Turngerät nach einem oder mehreren der vorhergehenden Ansprüche, **dadurch gekennzeichnet, dass** jedes in Längsrichtung entwickelte flexible Element (24, 25) ein Sicherheitsgegengewicht (35) aufweist.
  9. Turngerät nach Anspruch 3, **dadurch gekennzeichnet, dass** die elektronische Steuereinheit (90) konfiguriert ist, um jederzeit Folgendes zu überprüfen:
    - das Signal der Signalvorrichtung (85),
    - die Position der Hebestange (20),
    - die Geschwindigkeit der Hebestange (20),
    - und die Abwärtsbeschleunigung der Hebestange (20).
  10. Verfahren zum Betrieb eines Turngerätes (10) nach einem oder mehreren der Ansprüche 1 bis 9, **dadurch gekennzeichnet, dass** es die folgenden Arbeitsschritte umfasst:
    - Starten des Geräts (100);
    - einen Vorbereitungsschritt, der die folgende Abfolge von Aktionen (200) umfasst:
      - Positionieren der Langhantel (101), wobei die Langhantel, d. h. die Hebestange (20), auf eine vom Athleten festgelegte Höhe gebracht wird;
      - Betätigen (102) der Hands-on-Signalvorrichtung (85), die das Vorhandensein einer Hand auf der Hebestange (20) signalisiert, wodurch es dem Benutzerathleten ermöglicht wird, die Übung durchzuführen;
      - Durchführen von mindestens zwei unbelasteten Wiederholungen (103) der Bewegungen der Übung durch den Benutzerathleten, um der elektronischen Steuereinheit (90) die Position des oberen Totpunkts (OT) und des unteren Totpunkts (UT) des Hubs der Hebestange (20), d. h. der maximalen und minimalen Bodenabstandspunkte, die die Hebestange (20) während der Übung voraussichtlich erreichen wird, beizubringen oder sie dazu zu veranlassen, diese zu speichern;
      - Ablesen der Werte (104) durch die elektronische Steuereinheit (90), die die Aktivierung (h) der Hands-on-Signalvorrichtung (85), die Position (x), die Geschwindigkeit (x') und die Beschleunigung (x'') der Hebestange (20) erfasst;

- Analyse der Wiederholungen und Überprüfung, dass die durchgeführten Wiederholungen regelmäßig sind (105), das heißt, dass die Wiederholungen ähnliche untere Totpunkte (UT) und ähnliche obere Totpunkte (OT) aufweisen; 5
- wenn der vorhergehende Analyseschritt (105) Regelmäßigkeit in den Wiederholungen (106) erfasst, dann lässt der Benutzerathlet (107) die Hebestange (20) los, so dass das Signal in die Signalvorrichtung (85) gelangen kann; 10
- wenn der vorhergehende Analyseschritt (105) keine Regelmäßigkeit in den Wiederholungen (106) erfasst, dann führt der Benutzerathlet die Wiederholungen erneut durch (103); 15
- nach dem Loslassen der Hebestange (20) erfolgt die Positionierung (108) der Hebestange (20) im oberen Totpunkt (OT) oder unteren Totpunkt (UT). 20
- 11. Verfahren nach Anspruch 10, dadurch gekennzeichnet, dass** auf den Vorbereitungsschritt (200) ein Trainingsschritt (300) folgt, wobei der Trainingsschritt (300) die folgenden Arbeitsschritte umfasst: 25
- Betätigen (109) der Hands-on-Signalvorrichtung (85);
  - Lastaufbringung (110), d. h. die Elektromotoren (22, 23) liefern Drehmoment und erreichen die Trainingslast; 30
  - Ablesen (111) der Parameter von Position (x), Geschwindigkeit (x'), Beschleunigung (x'') und Zeit (t) nach der Aktivierung des Turngeräts (10) mittels der Hands-on-Signalvorrichtung (85), wobei die elektronische Steuereinheit (90) die Unterbrechung des Signals zwischen Sender und Empfänger der Signalvorrichtung (85) erfasst und die Position (x), Geschwindigkeit (x') und Beschleunigung (x'') der Hebestange (20) und die Zeit (t) der Durchführung der Übung erfasst; 35
  - Datenspeicherung (112), d. h. die elektronische Steuereinheit (90) führt eine Informationsspeicherung durch. 40
- 12. Verfahren nach dem vorhergehenden Anspruch, dadurch gekennzeichnet, dass** der Trainingsschritt (300) einen Zyklus von Sicherheitsvorgängen (400) umfasst, der immer bis zu einem Stoppschritt (116) des Abschlusses der Übung wiederholt wird. 45
- 13. Verfahren nach dem vorhergehenden Anspruch, dadurch gekennzeichnet, dass** der Zyklus von Sicherheitsvorgängen (400) die folgenden Arbeitsschritte umfasst: 50
- Revendications**
1. Appareil de gymnastique pour l'haltérophilie (10), comprenant: 55
- un cadre porteur (11),
  - deux premiers guides latéraux opposés (12, 13), s'étendant dans une première direction verticale (X1),
- Überprüfen (113) des Vorhandenseins von mindestens einer der Hände des Athleten auf der Hebestange (20) mittels der Signalvorrichtung (85);
- wenn die Signalvorrichtung (85) signalisiert, dass sich keine Hände auf der Hebestange (20) befinden, dann wird eine Datenspeicherung (114) durchgeführt und das Gerät wird gestoppt (116);
- wenn die Signalvorrichtung (85) das Vorhandensein von Händen auf der Hebestange (20) signalisiert, dann wird überprüft, ob die Höhe (x) der Hebestange (20) über oder unter einem Schwellenwert (Xs) für das Quetschen des Körpers des Athleten (115) liegt;
- wenn die Höhe (x) der Hebestange (20) unter einem Schwellenwert (Xs) für das Quetschen des Körpers des Athleten liegt, dann werden Datenspeicherung (114) und Übungsstopp (116) durchgeführt;
- wenn die Höhe (x) der Hebestange (20) über dem Schwellenwert (Xs) liegt und die Übung daher innerhalb der vordefinierten Sicherheitsgrenzen abläuft, dann wird überprüft (117), ob die Abwärtsgeschwindigkeit (x') der Hebestange (20) größer als ein Schwellenwert (Xs') ist;
- wenn die Abwärtsgeschwindigkeit (x') größer als der Schwellenwert (Xs') ist, dann werden Datenspeicherung (114) und Übungsstopp (116) durchgeführt;
- wenn die Abwärtsgeschwindigkeit (x') kleiner als der Schwellenwert (Xs') ist und die Übung daher innerhalb der vordefinierten Sicherheitsgrenzen abläuft, dann wird überprüft (118), ob die Abwärtsbeschleunigung (x'') der Hebestange (20) größer als ein Schwellenwert (Xs'') für den Sturz der Hebestange (20) ist;
- wenn die Abwärtsbeschleunigung (x'') größer als der Schwellenwert (Xs'') ist, dann werden Datenspeicherung (114) und Übungsstopp (116) durchgeführt;
- wenn die Abwärtsbeschleunigung (x'') kleiner als der Schwellenwert (Xs'') ist, dann wird die Übung mit einem Lastaufbringungsschritt (110) fortgesetzt oder ein Hilfsschritt (500) mit möglicher Reduzierung der Übungslast wird eingeleitet.

- deux premières glissières (14, 15), chacune contrainte par glissement sur un premier guide latéral correspondant (12, 13),
  - deux seconds guides latéraux opposés (16, 17), s'étendant dans une seconde direction (X2) transversale à ladite première direction verticale (X1), et chacun défini à bord de l'une desdites premières glissières (14, 15),
  - deux secondes glissières (18, 19), chacune contrainte par glissement sur un second guide latéral correspondant (16, 17),
  - une barre de levage (20), chacune des extrémités (20a, 20b) de ladite barre de levage (20) étant contrainte à une seconde glissière correspondante (18, 19),
  - des moyens de transmission motorisés (21) configurés pour appliquer sur lesdites premières glissières (14, 15) soit une force opposée à une force de poussée vers le haut, soit une force de traction vers le bas,
- caractérisé en ce que** lesdits moyens de transmission motorisés (21) comprennent deux moteurs électriques (22, 23) dont chacun est configuré pour actionner un élément flexible correspondant à développement longitudinal (24, 25), chaque élément flexible à développement longitudinal (24, 25) étant relié à une première extrémité à la partie inférieure (14a, 15a) d'une première glissière (14, 15) des deux premières glissières, et à la seconde extrémité opposée étant relié à la partie supérieure (14b, 15b) de la même première glissière (14, 15), lesdits moyens de transmission motorisés (21) comprenant, pour chaque élément flexible à développement longitudinal (24, 25):
- au moins une poulie inférieure (26) configurée et positionnée pour dévier l'élément flexible à développement longitudinal (24, 25) provenant dudit moteur électrique (22, 23) vers ladite partie inférieure (14a, 15a) de ladite première glissière (14, 15),
  - au moins une poulie supérieure (28, 29, 30, 31) configurée et positionnée pour dévier ledit élément flexible à développement longitudinal (24, 25) vers une partie supérieure (14b, 15b) de ladite première glissière (14, 15).
2. Appareil de gymnastique selon la revendication 1, **caractérisé en ce qu'il** comprend en outre un transducteur de vitesse supplémentaire, pour chacune des premières glissières (14, 15).
3. Appareil de gymnastique selon une ou plusieurs des revendications précédentes, **caractérisé en ce qu'il** comprend une unité électronique (90) pour commander le fonctionnement desdits moyens de transmission motorisés (21).
4. Appareil de gymnastique selon une ou plusieurs des revendications précédentes, **caractérisé en ce que** lesdits moteurs électriques (22, 23) sont du type sans balais.
5. Appareil de gymnastique selon une ou plusieurs des revendications précédentes, **caractérisé en ce que** chacun desdits moteurs électriques (22, 23) comprend un encodeur et un frein intégré.
6. Appareil de gymnastique selon une ou plusieurs des revendications précédentes, **caractérisé en ce que** lesdits éléments flexibles à développement longitudinal (24, 25) comprennent une courroie, une chaîne, une corde ou d'autres éléments similaires et équivalents.
7. Appareil de gymnastique selon une ou plusieurs des revendications précédentes, **caractérisé en ce qu'il** comprend un dispositif (85) de signalisation de la saisie et de la libération de ladite barre de levage (20) par un utilisateur, ledit dispositif de signalisation (85) étant relié à ladite unité de commande électronique (90).
8. Appareil de gymnastique selon une ou plusieurs des revendications précédentes, **caractérisé en ce que** chaque élément flexible à développement longitudinal (24, 25) comprend un contrepoids de sécurité (35).
9. Appareil de gymnastique selon la revendication 3, **caractérisé en ce que** ladite unité de commande électronique (90) est configurée pour vérifier à tout moment:
- le signal dudit dispositif de signalisation (85),
  - la position de ladite barre de levage (20),
  - la vitesse de ladite barre de levage (20),
  - et l'accélération descendante de ladite barre de levage (20).
10. Procédé de fonctionnement d'un appareil de gymnastique (10) selon une ou plusieurs des revendications 1 à 9, **caractérisée en ce qu'il** comprend les étapes de fonctionnement suivantes:
- le démarrage de l'appareil (100);
  - une étape de préparation, comprenant la séquence d'actions suivante (200):
  - le positionnement de la barre (101), dans lequel la barre, c'est-à-dire ladite barre de levage (20), est amenée à une hauteur fixée par l'athlète;
  - l'actionnement (102) du dispositif de si-

- gnalisation de la main (85), qui signale la présence d'une main sur la barre de levage (20), ce qui permet à l'athlète utilisateur d'effectuer l'exercice;
- la réalisation d'au moins deux répétitions sans charge (103) des mouvements de l'exercice par l'athlète utilisateur, afin d'apprendre ou de faire mémoriser par l'unité de commande électronique (90) la position du point mort haut (PMH) et du point mort bas (PMB) de la course de la barre de levage (20), c'est-à-dire les points de garde au sol maximum et minimum que la barre de levage (20) est censée atteindre au cours de l'exercice;
  - la lecture des valeurs (104) par l'unité de commande électronique (90), qui détecte l'activation (h) du dispositif de signalisation de la main (85), la position (x), la vitesse (x') et l'accélération (x'') de ladite barre de levage (20);
  - l'analyse des répétitions et la vérification que les répétitions effectuées sont régulières (105), c'est-à-dire que les répétitions ont des points morts bas (PMB) similaires et des points morts hauts (PMH) similaires;
  - si l'étape d'analyse précédente (105) détecte la régularité des répétitions (106), l'athlète utilisateur libère (107) la barre de levage (20), permettant au signal de passer dans le dispositif de signalisation (85);
  - si l'étape d'analyse précédente (105) ne détecte pas la régularité des répétitions (106), l'athlète utilisateur effectue à nouveau les répétitions (103);
  - après la libération de la barre de levage (20), il y a le positionnement (108) de la barre de levage (20) au point mort haut (PMH) ou au point mort bas (PMB).
- 11.** Procédé selon la revendication 10, **caractérisé en ce que** ladite étape de préparation (200) est suivie d'une étape d'apprentissage (300), ladite étape d'apprentissage (300) comprenant les étapes de fonctionnement suivantes:
- l'actionnement (109) du dispositif de signalisation de la main (85);
  - l'application de charge (110), c'est-à-dire que les moteurs électriques (22, 23) fournissent un couple et atteignent la charge d'apprentissage;
  - la lecture (111) des paramètres de position (x), vitesse (x'), accélération (x'') et temps (t), suite à l'activation de l'appareil de gymnastique (10) au moyen du dispositif de signalisation de la main (85), ladite unité de commande électronique (90) détectant l'interruption du signal entre l'émetteur et le récepteur du dispositif de signalisation (85), et détecte la position (x), la vitesse (x') et l'accélération (x'') de ladite barre de levage (20) et le temps (t) d'exécution de l'exercice;
  - la sauvegarde des données (112), c'est-à-dire que l'unité de commande électronique (90) assure le stockage des informations.
- 12.** Procédé selon la revendication précédente, **caractérisée en ce que** ladite étape d'apprentissage (300) comprend un cycle d'opérations de sécurité (400) toujours itéré jusqu'à une étape d'arrêt (116) de conclusion de l'exercice.
- 13.** Procédé selon la revendication précédente, **caractérisée en ce que** ledit cycle d'opérations de sécurité (400) comprend les étapes opérationnelles suivantes:
- la vérification (113) de la présence d'au moins une des mains de l'athlète sur la barre de levage (20) au moyen dudit dispositif de signalisation (85);
  - si le dispositif de signalisation (85) signale qu'il n'y a pas de mains sur la barre de levage (20), la sauvegarde des données (114) est effectuée et l'appareil est arrêté (116);
  - si le dispositif de signalisation (85) signale la présence de mains sur la barre de levage (20), on vérifie si la hauteur (x) de la barre de levage (20) est supérieure ou inférieure à une valeur seuil (Xs) d'écrasement du corps de l'athlète (115);
  - si la hauteur (x) de la barre de levage (20) est inférieure à une valeur seuil (Xs) d'écrasement du corps de l'athlète, la sauvegarde des données (114) et l'arrêt de l'exercice (116) sont effectués;
  - si la hauteur (x) de la barre de levage (20) est supérieure à la valeur seuil (Xs), et donc l'exercice se déroule dans les limites de sécurité prédéfinies, on vérifie (117) si la vitesse de descente (x') de la barre de levage (20) est supérieure à une valeur seuil (Xs');
  - si la vitesse de descente (x') est supérieure à ladite valeur seuil (Xs'), la sauvegarde des données (114) et l'arrêt de l'exercice (116) sont effectués;
  - si la vitesse de descente (x') est inférieure à ladite valeur seuil (Xs'), et donc l'exercice se déroule dans les limites de sécurité prédéfinies, on vérifie (118) si l'accélération descendante (x'') de la barre de levage (20) est supérieure à une valeur seuil (Xs'') de chute de la barre de levage (20);
  - si l'accélération descendante (x'') est supérieure à ladite valeur seuil (Xs''), la sauvegarde des données (114) et l'arrêt de l'exercice (116) sont effectués;

- si l'accélération descendante ( $x''$ ) est inférieure à ladite valeur seuil ( $Xs''$ ), l'exercice se poursuit avec une étape d'application de charge (110), ou une étape auxiliaire (500) de réduction éventuelle de la charge d'exercice intervient.

5

10

15

20

25

30

35

40

45

50

55

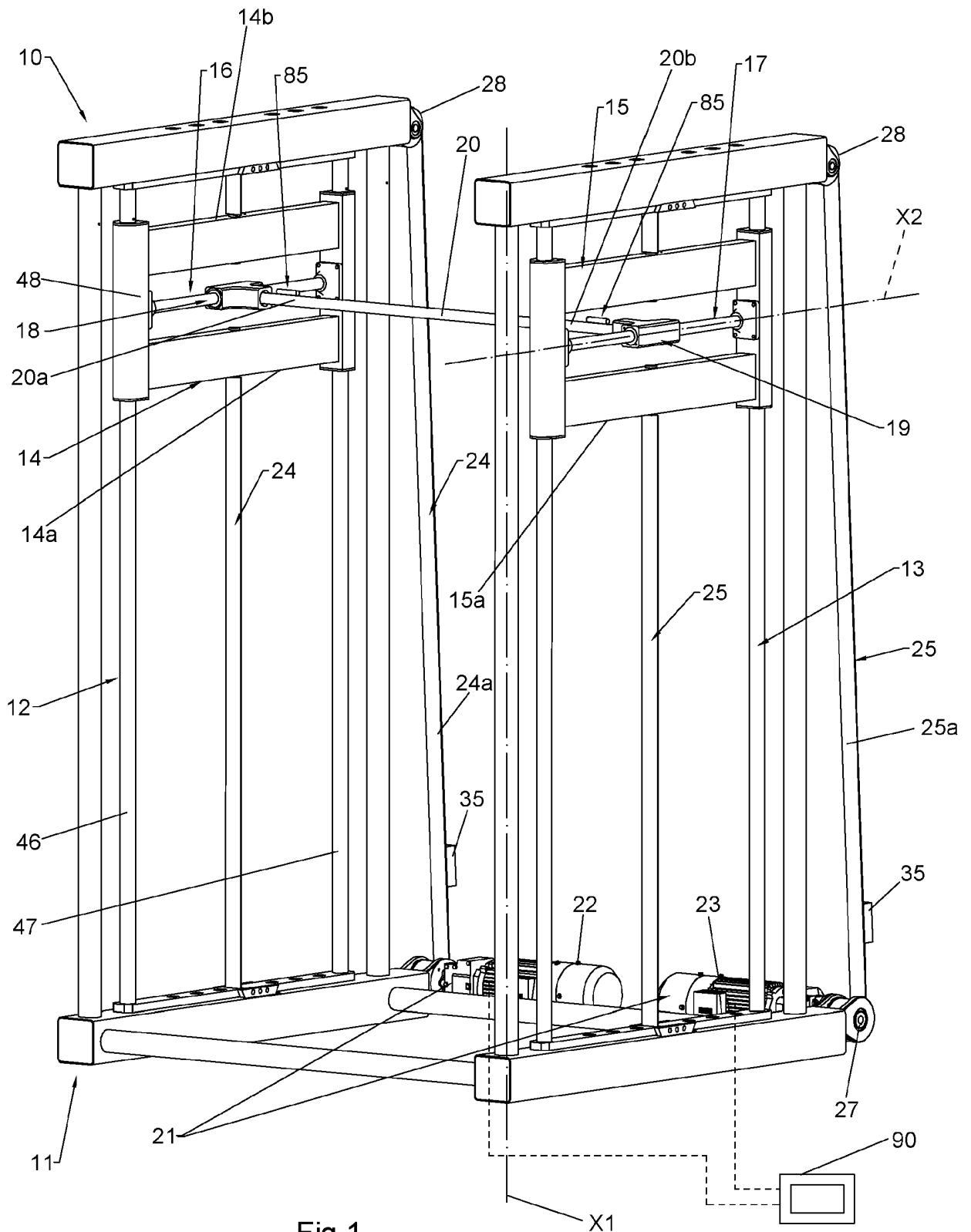

Fig.1

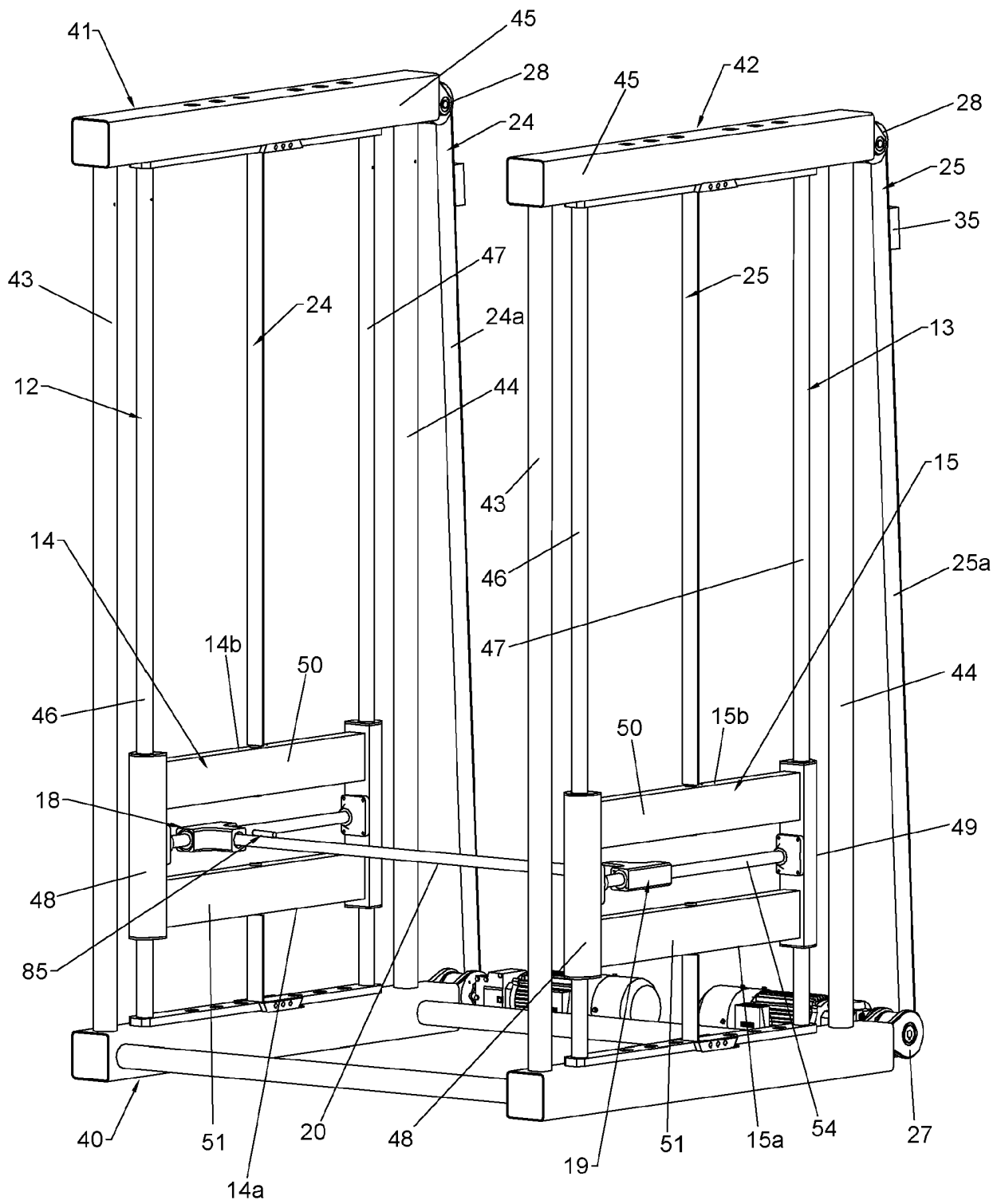
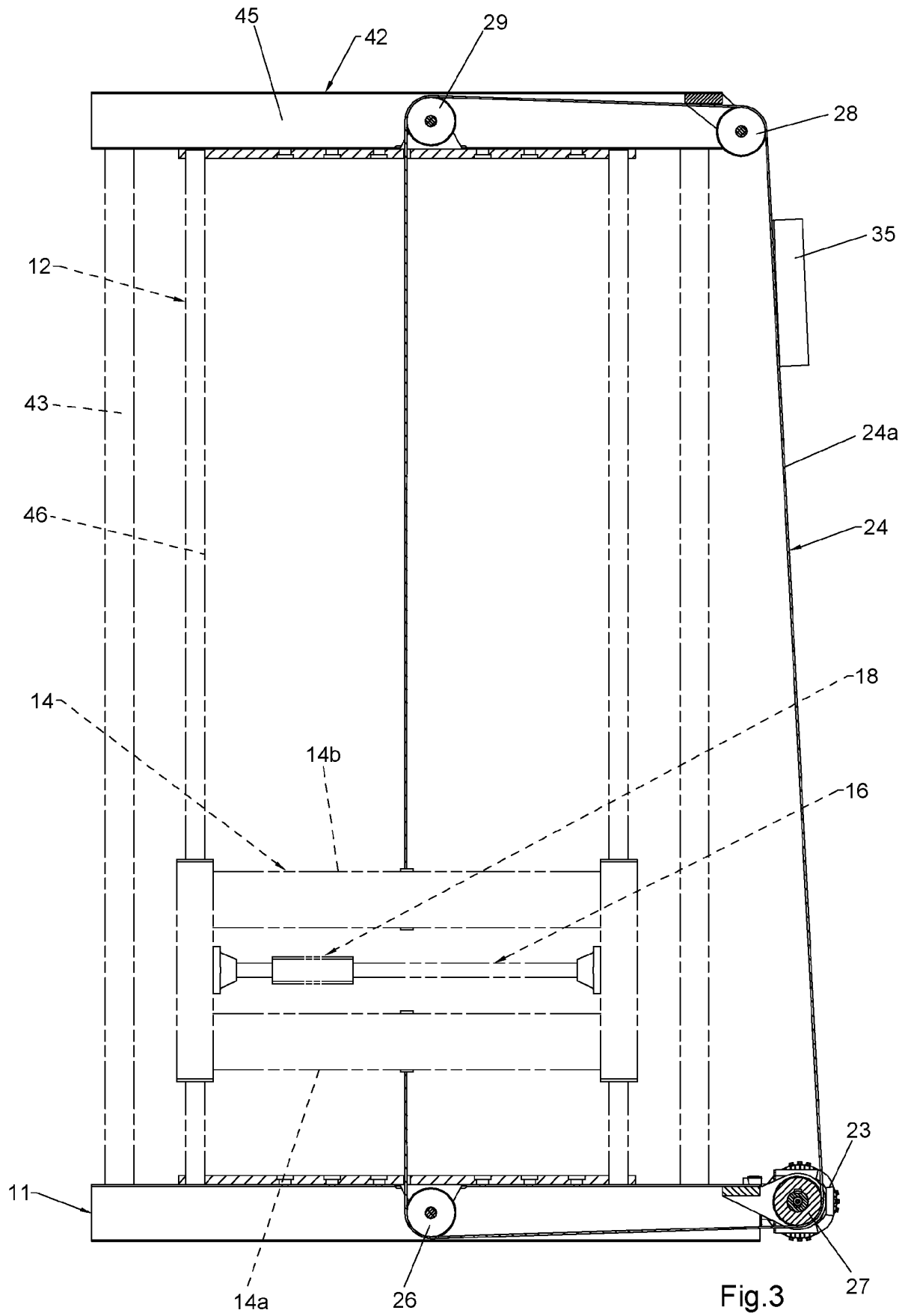
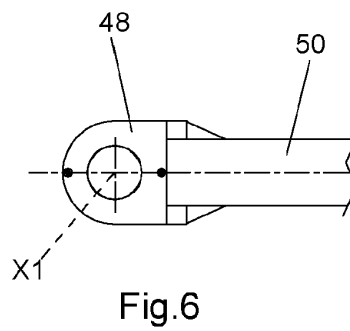
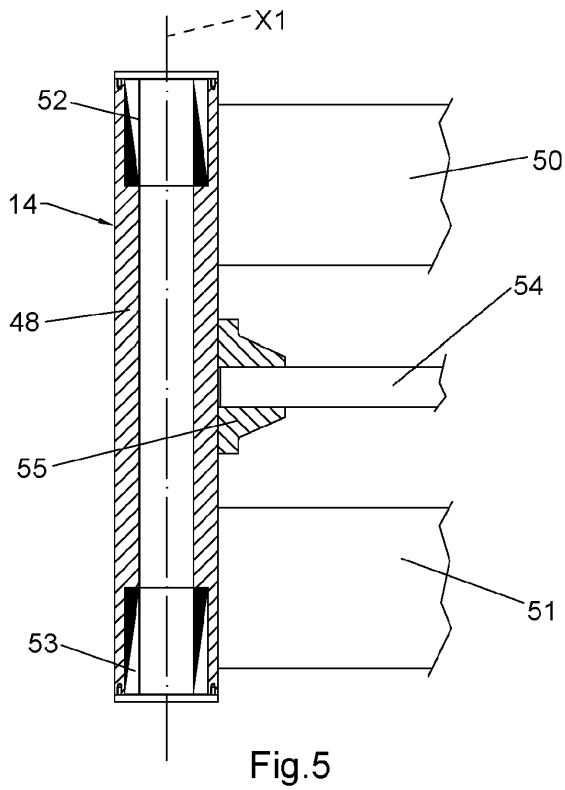
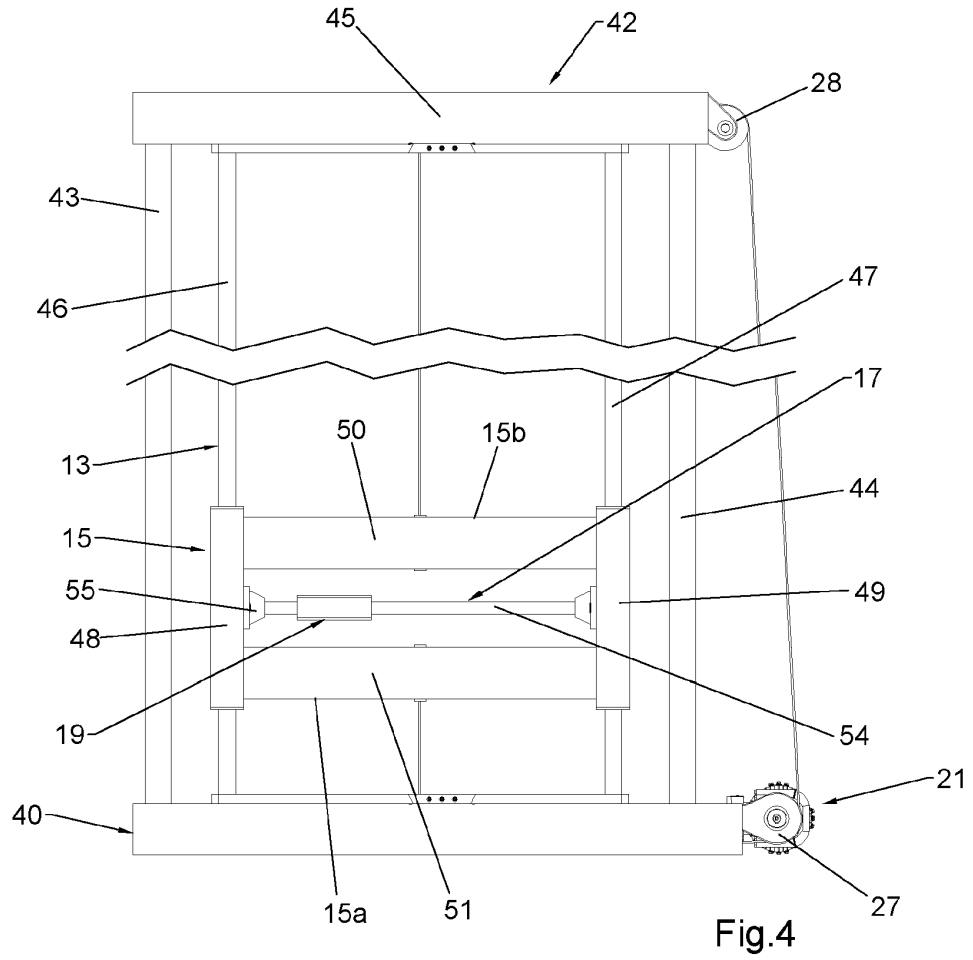
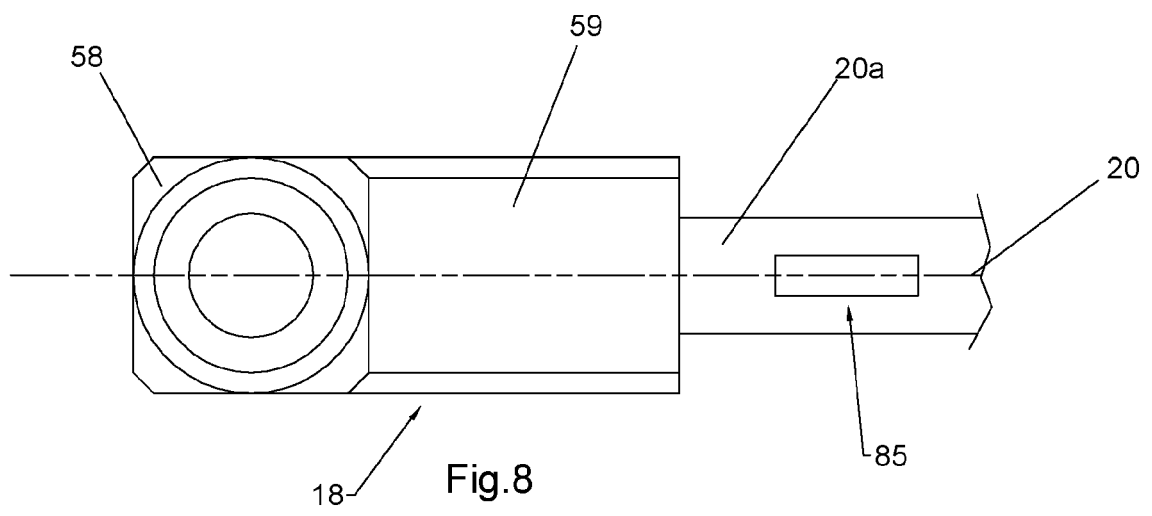
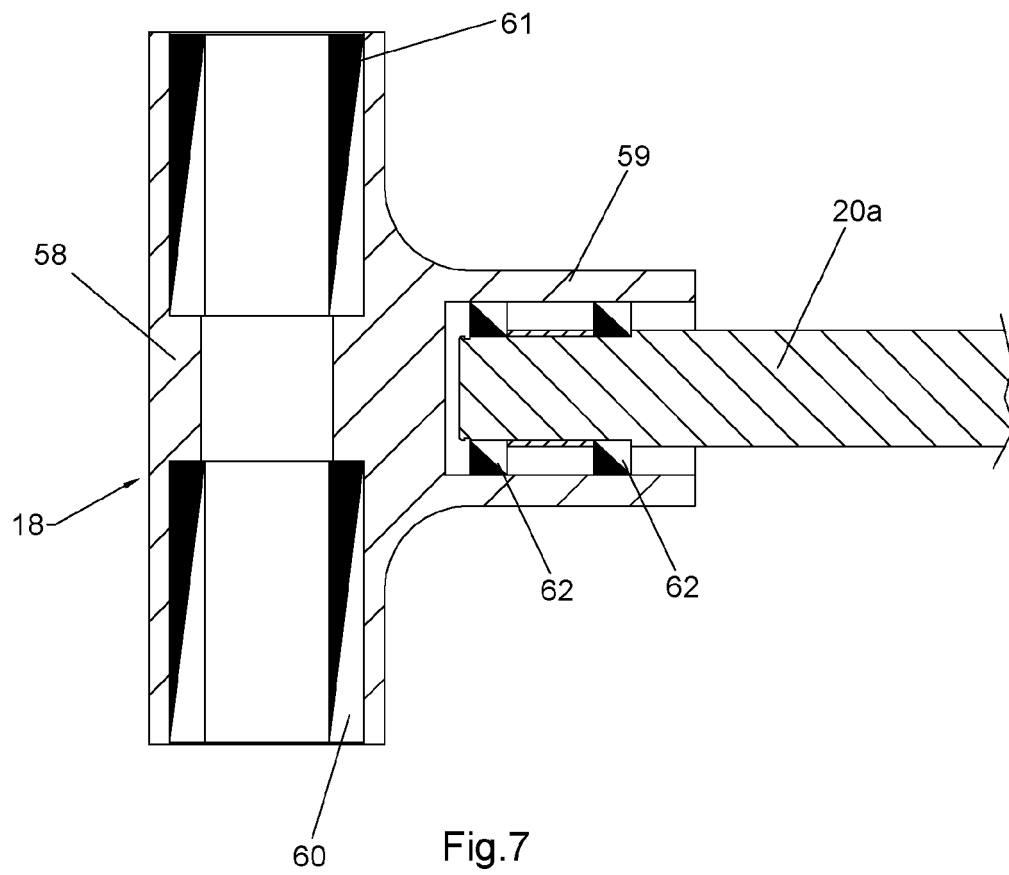

Fig.2







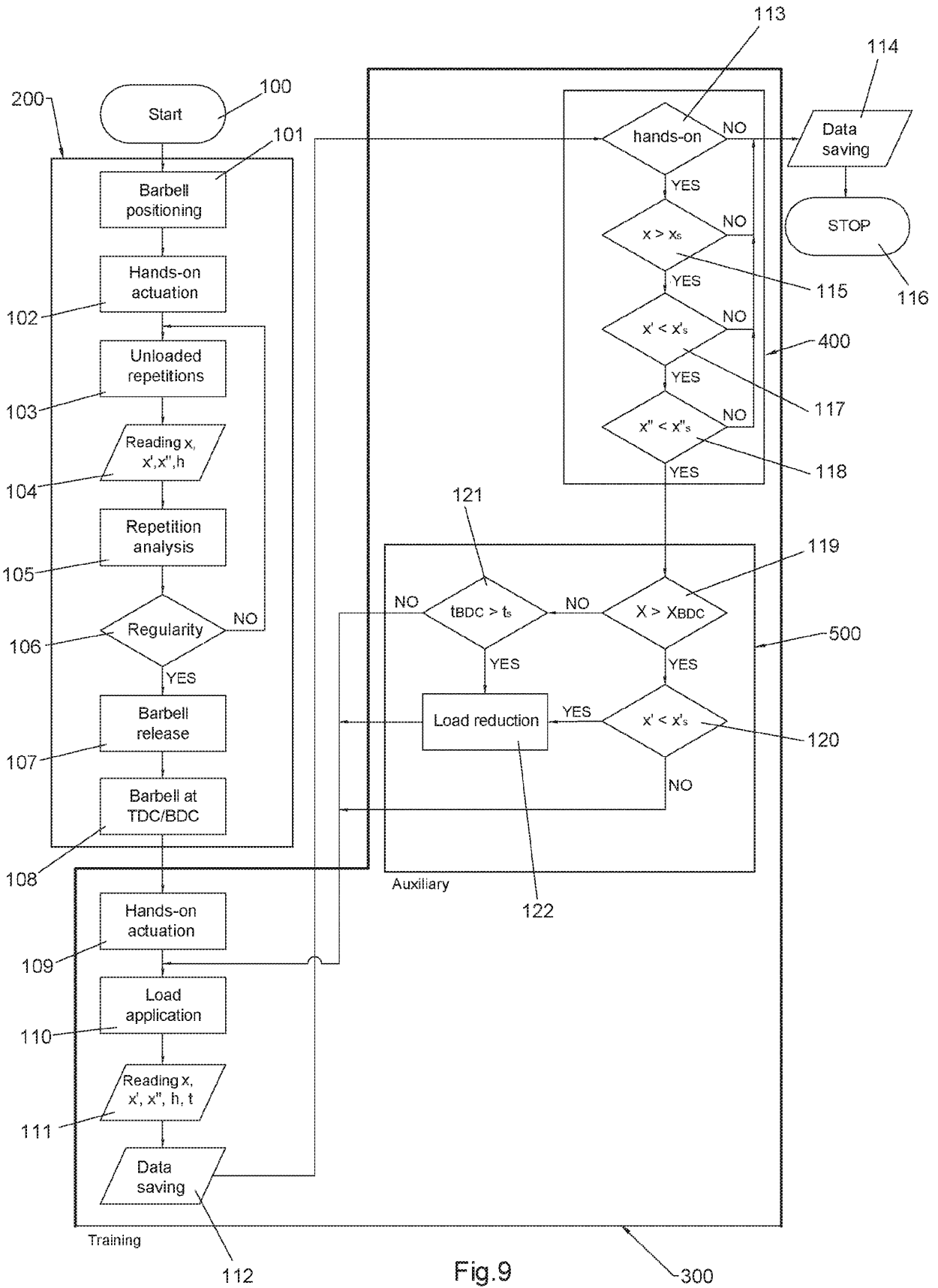

Fig.9

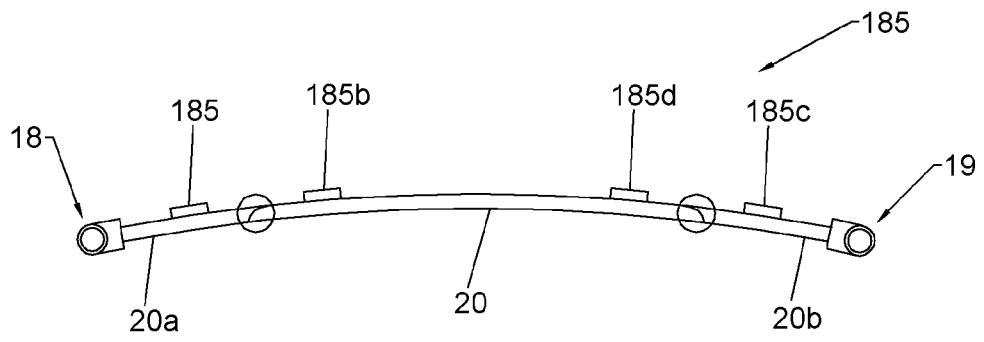

Fig.10

**REFERENCES CITED IN THE DESCRIPTION**

*This list of references cited by the applicant is for the reader's convenience only. It does not form part of the European patent document. Even though great care has been taken in compiling the references, errors or omissions cannot be excluded and the EPO disclaims all liability in this regard.*

**Patent documents cited in the description**

- US 2020023227 A1 [0007]