

No. 765,151.

PATENTED JULY 12, 1904.

J. B. SOULE.
AUTOMATIC ATTACHMENT FOR ELEVATOR BELTS.

APPLICATION FILED JAN. 8, 1904.

NO MODEL.

3 SHEETS—SHEET 1.

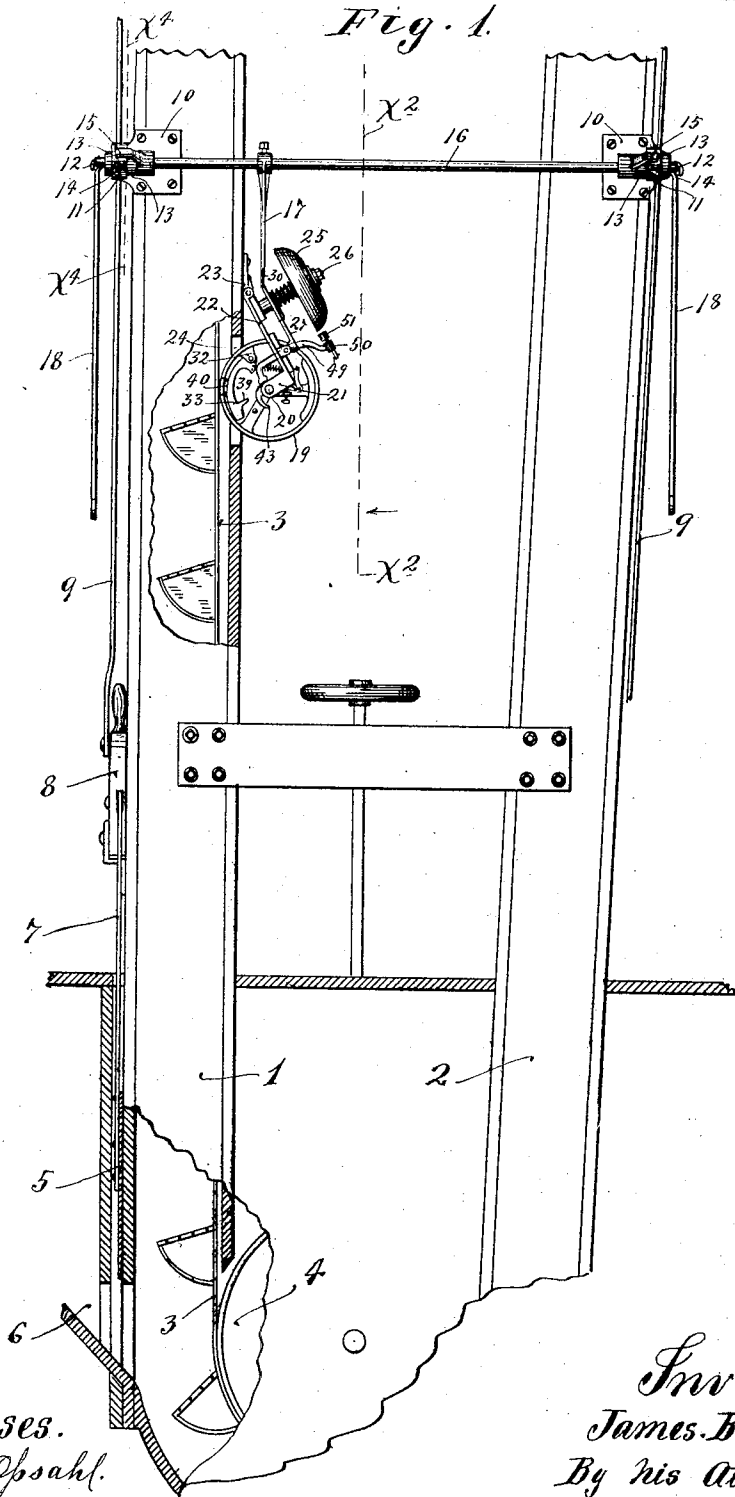

Witnesses.
A. H. Opsahl.
H. P. Kellogg

Inventor.
James B. Soule.
By his Attorneys.
William M. Merchant

J. B. SOULE.
AUTOMATIC ATTACHMENT FOR ELEVATOR BELTS.

APPLICATION FILED JAN. 8, 1904.

NO MODEL.

3 SHEETS—SHEET 2.

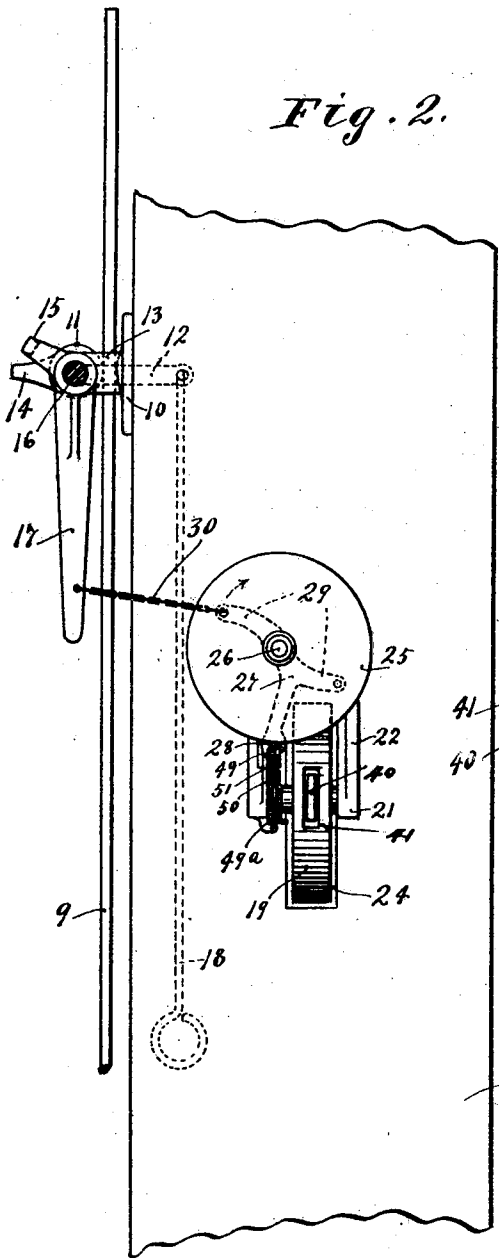

Fig. 2.

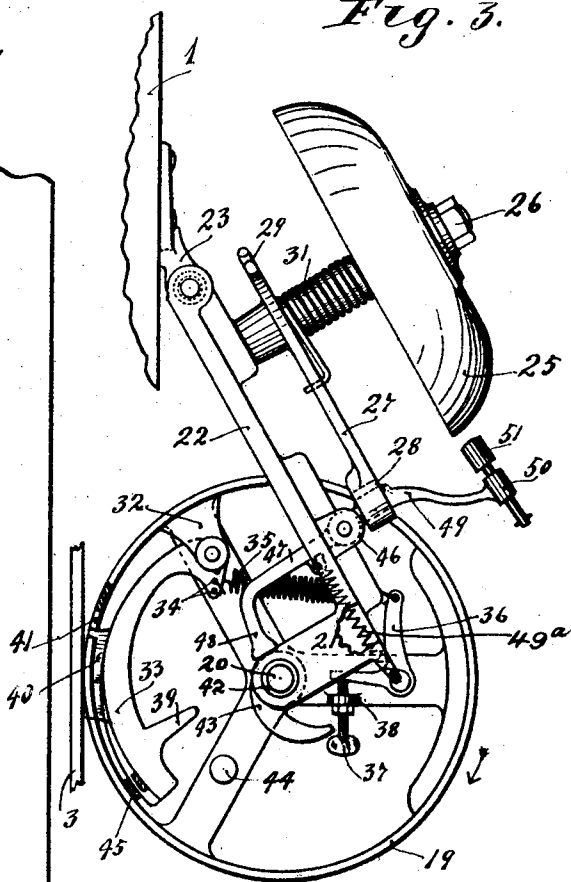

Fig. 3.

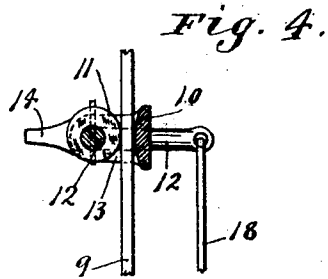

Fig. 4.

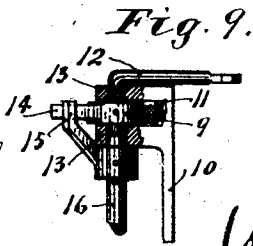

Fig. 9.

Witnesses
a. H. Opsahl.
H. H. Nelson.

Inventor.
James B. Soule.
 By his Attorneys.
Williamson & Merchant

J. B. SOULE.
AUTOMATIC ATTACHMENT FOR ELEVATOR BELTS.

APPLICATION FILED JAN. 8, 1904.

NO MODEL.

3 SHEETS—SHEET 3.

Fig. 5.

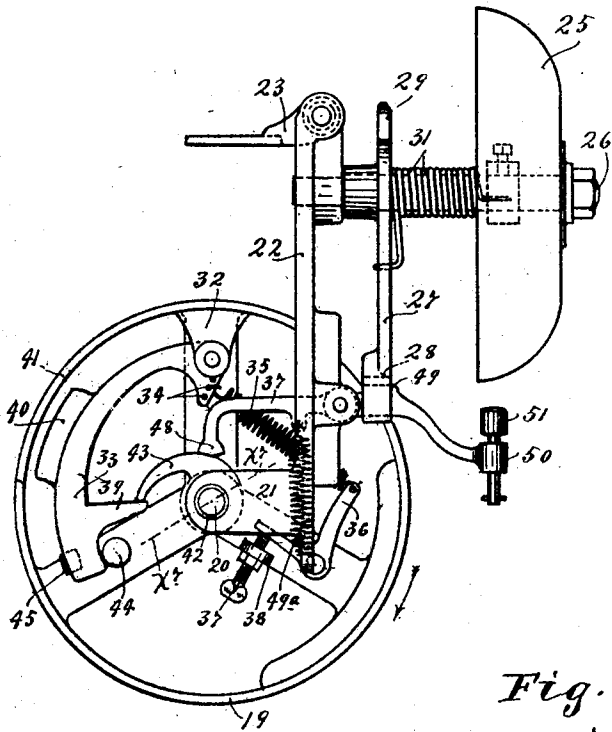

Fig. 6.

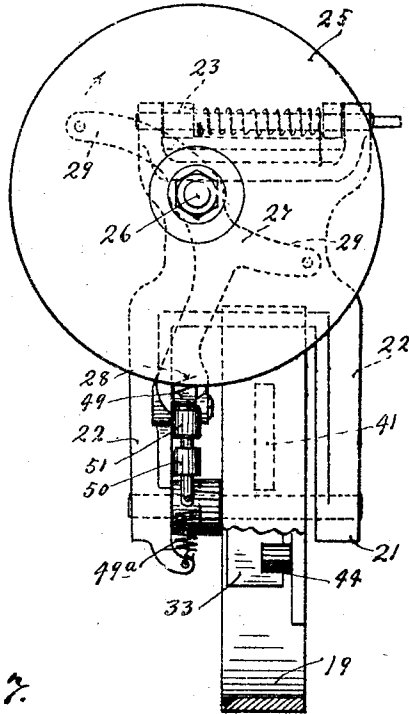

Fig. 7.

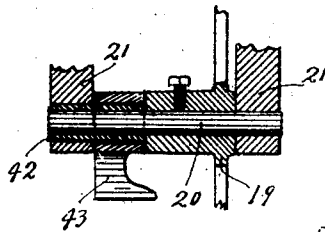
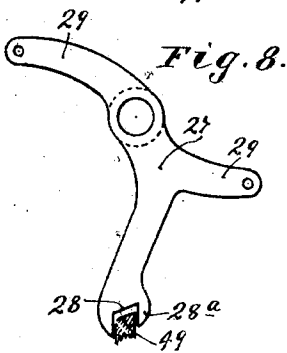
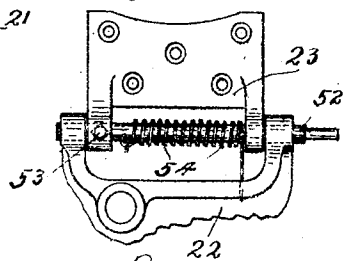

Fig. 10.



Witnesses.
A. H. Opsahl.
H. D. Kiger

Inventor.
James B. Soule.
By his Attorneys.
Williamson & Merchant

UNITED STATES PATENT OFFICE.

JAMES B. SOULE, OF MINNEAPOLIS, MINNESOTA, ASSIGNOR OF ONE-HALF TO THE CENTRAL MACHINE WORKS COMPANY, OF MINNEAPOLIS, MINNESOTA, A CORPORATION OF MINNESOTA.

AUTOMATIC ATTACHMENT FOR ELEVATOR-BELTS.

SPECIFICATION forming part of Letters Patent No. 765,151, dated July 12, 1904.

Application filed January 8, 1904. Serial No. 188,177. (No model.)

To all whom it may concern:

Be it known that I, JAMES B. SOULE, a citizen of the United States, residing at Minneapolis, in the county of Hennepin and State of Minnesota, have invented certain new and useful Improvements in Automatic Attachments for Elevator-Belts; and I do hereby declare the following to be a full, clear, and exact description of the invention, such as will enable others skilled in the art to which it appertains to make and use the same.

My present invention relates to automatic attachments for elevator-belts or other belts used in the transmission of power, which attachments may be used to operate a safety cut-off device or an alarm device, or both; and to such ends the invention consists of the novel devices and combinations of devices hereinafter described, and defined in the claims.

In the illustration of my invention, as given in the drawings, this automatic attachment is shown as applied to an elevator-belt and as arranged to automatically operate an elevator feed-gate and to simultaneously sound a gong or alarm device.

The invention involves certain important features which render the proper automatic action of the device certain and which generally improve the construction and operation of the device, as will hereinafter more fully appear.

The invention is illustrated in the accompanying drawings, wherein like characters indicate like parts throughout the several views.

Figure 1 is a view in side elevation with some parts sectioned and others broken away, showing the legs and belt of an ordinary grain-elevator wherein a cup-belt is employed and showing my invention applied thereto to automatically operate the feed-gate and to sound a gong. Fig. 2 is a transverse vertical section taken on the line $x^2 x^2$ of Fig. 1. Fig. 3 is an enlarged view in side elevation showing the so-called "wheel-head" and the gong, the said parts being viewed in the same direction as in Fig. 1. Fig. 4 is a detail in section on the line $x^3 x^4$ of Fig. 1. Fig. 5 is a view corresponding to Fig. 3, showing the parts

of the governor or centrifugal tripping device in different positions. Fig. 6 is an elevation looking at the parts shown in Fig. 5 from the right toward the left. Fig. 7 is a detail in section approximately on the line $x^1 x^1$ of Fig. 5. Fig. 8 is a detail of the trip-lever. Fig. 9 is a detail in plan of the parts shown in Fig. 4, some parts being sectioned; and Fig. 10 is a detail of the hinge of the wheel-supporting plate.

The numerals 1 and 2 indicate, respectively, the front and back legs of the elevator, and the numeral 3 indicates the cup-equipped belt which runs over suitable wheels 4, only one of which is shown in the drawings.

The numeral 5 indicates the elevator feed-gate, which gate opens and closes a feed-passage into the lower portion of the front leg 1. The inlet-passage into the lower end of the rear leg 2 and the gate for opening and closing the same are not shown in the drawings, these parts being of the usual construction. The gate 5, as is usual, is connected by a rod 7 to a lift-lever 8, pivoted to the leg 1, and the gate for the rear leg, it will be understood, is connected in the same way. Both of the levers 8 (only one of which is shown) are pivotally connected to the lower ends of long vertically-extended rods 9, the upper ends of which are adapted to be held and clamped between anvil-plates 10 and eccentrics 11, which eccentrics, as shown, are rigid on rocking cranks 12, journaled in the lugs 13 of the anvil-plates 10, which plates are rigidly secured one to each elevator-leg. The eccentrics 11 have outwardly-projecting trip-lugs 14, that are adapted to be engaged and pressed down by laterally-bent trip-fingers 15 of a transverse rock-shaft 16, the ends of which rock-shaft, as shown, are loosely journaled in the inner members of the bearing-lugs 13. The rock-shaft 16 is provided at its intermediate portion with a quite long depending trip-arm 17. From the free end of each crank 12 loosely depends a hand-rod 18, by means of which said cranks may be forced upward at will to release the rods 9 and drop the gates 5 independently of the automatic mechanism.

The automatic mechanism will now be described. A governor-wheel 19 is loosely journaled in an oscillating support, its shaft 20, as shown, being journaled in lugs 21 of a supporting-plate 22, which plate is pivoted at its upper end to a lug 23, rigidly secured to the rear wall of the front leg 1. This wheel 19 has frictional contact with the back of the elevator-belt 3, the rear wall of said leg 1 being cut away at 24 to permit such engagement.

The gong or bell 25 is, as shown, rigidly secured on the outer end of a long stud 26, the other end of which is rigidly secured to the hinged or oscillating supporting-plate 22. On this same stud 26 is pivoted a trip-lever 27, the lower end of which has a notch 28 and a beveled lug 28^a, which, as will be presently noted, cooperate with a combined lock-lever and gong-hammer. The trip-lever 27 is provided with oppositely-projecting arms 29, one or the other of which is connected by a chain 30 or other suitable connection to the depending trip-arm 17 of the rock-shaft 16. When the rock-shaft 16 is applied on the left-hand side of the leg, as shown in Fig. 2, said chain 30 is connected to the upper arm 29; but when the said rock-shaft is applied on the right-hand side of the said leg the said chain would necessarily be connected to the lower arm 29. A strong coiled spring 31, wound on the stud 26, with one end anchored to the said stud and with its other end acting on the trip-lever 27, tends to move the said trip-lever in the direction indicated by the arrow marked on Fig. 2, this direction of movement of the said lever being that which is required to move the eccentrics 11, so as to release the rods 9 and drop the gates 5 into closed positions.

Working within the wheel 19 and pivoted to lugs 32 thereof is a segmental centrifugally-actuated governor-arm 33. Near its pivoted end this governor-arm is provided with a projecting flange, preferably having a plurality of perforations 34, into any one of which is hooked one end of a coiled spring 35, the other end of which spring is attached to one arm of a bell-crank 36. This bell-crank 36 affords an adjustable base of reaction for said spring and is subject to an adjusting-screw 37, that works through a lug 38 on the same arm of the wheel 19 to which the said bell-crank is pivoted. The governor-arm 33 near its free end is provided with an inwardly-projecting tripping-lug 39, and at its intermediate portion it is provided with an outwardly-projecting agitating lug or flange 40, which works through a slot 41 in the rim of the wheel 19 and is brought into engagement with the belt 3 to produce an action of the greatest importance, and which will hereinafter be more fully described.

One of the lugs 21 of the supporting-plate 22 has an inwardly-projecting sleeve 42, which

is held against rotation and on which is loosely journaled a tripping-cam 43. The lug 39 of the governor-lever 33 operates on this cam 43 at a time and in a manner which will be hereinafter set forth. The spring 35 normally holds the free end of the governor-lever 33 against a stop 44 on one of the arms of the wheel 19. This stop 44 is preferably covered with rubber to prevent noise, and the said lever 33 is preferably provided at its free end with an inserted lever-stop 45, which engages with the rim of the wheel when the said lever is thrown outward to its extreme position.

Working through a passage in the supporting-plate 22 and pivoted to lugs 46 thereof is a combined lock-lever and gong-hammer 47, having at its inner end a laterally-bent foot 48, with which the cam 43 engages to move said lever into a position to release the trip-lever 27 and to actuate the gong. Just outward of its pivoted end lever 47 is formed with a beveled surface 49, that normally engages with the notch 28 of said lever 27, and under the closing movement of the said lever 27 engages with the cam-lug 28^a thereof. At its free or outer end this lock-lever 47 is formed with a short sleeve 50, through which loosely works, with freedom for axial movements, the stem of a sliding hammer-head 51. A coiled spring 49^a, attached at one end to the lever 47 and at its other end to the plate 22, yieldingly draws the foot 48 of said lever against the hub of the cam 43. This spring 49^a, when the lever-foot 48 is forced upward by the cam 43 and then released, serves to impart the gong-engaging blow or movement to the hammer 51.

The oscillating support 22 is pivotally connected to the lug 23 by a hinge-bolt 52, which, as shown, is adjustably secured to one of the ears of the lug 23 by a set-screw 53. The coiled spring 54, wound on the bolt 52, is secured at one end to said bolt and at its other end reacts on the plate 22. This spring 54 affords adjustable means for yieldingly pressing the wheel 19 into frictional engagement with the elevator-belt.

Operation: As is evident, the wheel 19 is supported in such manner that its own weight and that of the hinged support 22 and parts carried thereby will hold the said wheel in frictional engagement with the back of the elevator-belt 3, so that the said wheel will be rotated at a speed depending on the speed of travel of the said elevator-belt. The spring 25 is set under such tension that when the elevator-belt is running at a predetermined high speed—to wit, at a normal speed which is desired for the proper delivery of the grain—the so-called “governor-arm” 33 will be thrown outward by centrifugal force against the tension of the said spring, and hence under normal speed the trip-lug 39 of the said governor-arm will pass outward of and clear the trip-cam 43, and under these conditions the gong will not be sounded and the feed-gates will

be held in their elevated or open positions, so that a free supply of grain will delivered into the elevator-belt. When, however, the speed of the elevator-belt is reduced below the normal predetermined speed, as will happen when the elevator-leg becomes clogged with grain, the spring 35, acting on said governor-arm 33, will draw the same inward and so position it that its trip-lug 39 will engage the trip-cam 43 and cause the said trip-cam to rotate with the wheel 19. The first revolution of the cam 43 will cause the same to act on the foot 48 of the lock-lever 49, and thereby move the said lever out of engagement with the trip-lever 27, and thereby release the latter. The trip-lever 27 being released its spring will move it in the direction indicated by the arrow marked in Fig. 2, and thereby draw the trip-arm 17 toward the elevator-leg, thus rocking the rock-shaft 16 and eccentrics 11, causing the latter to release their grip on the gate-rods 9. The gate-rods 9 being released the gates 5 will, as is evident, be dropped into closed positions and cut off the further supply of grain to the elevator-legs. The trip-cam 43 under each rotation engages the foot 48 of the lever 47 and forces the same into a retracted position against the tension of its actuating-spring 49* and then suddenly releases the same, permitting said spring to throw said lever suddenly back to normal position, under which movement the sliding hammer-head 51 is thrown against the gong, thereby sounding the said gong or alarm device. The sliding hammer-head 51 after striking the gong is by recoil of the blow and by the action of gravity instantly thrown out of contact with the gong, so that it does not interfere with the free vibrations of the said gong. As is evident, the gong will be sounded under each rotation of the wheel 19, so long as the elevator-belt is running at a speed lower than the predetermined desired or normal speed. Whenever the proper speed of the elevator-belt is again established, the governor 33 will again be thrown outward, so that its lug 39 will clear the trip-cam 43 and the gong will no longer be sounded. The lock-lever 27 may be set or again locked by the combined lock-lever and bell-hammer 47 by taking hold of the depending arm 17 of the rock-shaft 16 and forcing the same outward or away from the elevator-leg back into the normal position indicated in Fig. 2. The gates 5 may be independently raised by their levers 8, and when they are raised their suspending-rods 9 are also raised. The suspending-rods 9, having thus been raised, may be gripped and held by their cooperating eccentrics 11, which are forced into operative positions by forcing downward their respective rods 18. Furthermore, the said eccentrics are by the weight of their rods 18 put under strain to bite upon the rods 9 and hold the same against downward movement. It is evident that when one of the rods 9 is pinched or gripped between the corresponding anvil-block 10 and cooperating eccentric 11 any downward strain thereon will simply tend to cause the said eccentric to press more firmly against the said rod. It will of course be understood that when the rock-shaft 16 is moved by the automatic release of the trip-lever 27 the trip-fingers 15 thereof, by engagement with the trip-lugs 14, move the eccentrics 11 simultaneously upward into positions to release the gate-supporting rods 9. The range of action of the governor-spring 35 may be varied by shifting it from one to the other of the perforations 34 of the governor-lever 33, thereby changing the leverage action. When the elevator-belt is running at or above the predetermined normal speed, and it will frequently thus run for a considerable length of time, the governor-lever 33 will be thrown outward, as already described, and under these conditions the agitating-lug 40 of the said governor-arm will under each rotation of the wheel 19 be brought into contact with the elevator-belt, and by this means the said governor-arm is kept under a continuing intermittent movement. This intermittent movement of the governor-arm keeps the same loosened up on its pivotal support and prevents the same from becoming clogged or stuck by the accumulation of dust or dirt or by the accumulation of a pasty ingredient formed by the mixture of lubricating-oil and of dust or dirt. Without this agitating device an automatic governor for the above purpose will sometimes become stuck, so that it fails to perform the functions for which it was intended. This automatic agitating device it will therefore be understood is an extremely important feature of my present invention. The form of governor illustrated and the means for agitating the same by contact with the elevator-belt represents what I believe to be the best form of the said devices; but I do not, however, limit myself to such forms. On the contrary, I believe an automatic agitator for a governor or automatic trip device used for the purposes herein set forth or for similar purposes to be, broadly, new, and desire this application to claim the same from the broadest possible point of view. With respect to the manner in which the lug 39 of the governor-lever 33 leaves engagement with the trip-cam 43 when the predetermined speed of the elevator-belt is attained it may be here further noted that this disengagement will naturally take place when the said governor-arm is in its lowermost position or at the lowest point of its revolution, at which time gravity assists centrifugal force in disengaging the said parts. This leaves the said trip-cam standing in a depending operative position, as clearly shown in Fig. 3. It will be remembered that the trip-cam 43 is mounted on a non-rotary sleeve. This is important, because if the said cam were

mounted on a part arranged to rotate with the wheel 19 the accumulation of dust or dirt in the bearing of the said cam might cause the said cam to be stuck to the rotary part, so that it would be rotated therewith, and thus sound the gong or trip the gates at a time when such actions are not desirable.

From the foregoing description and statements made it will be understood that the mechanism described is capable of many modifications within the scope of my invention, as herein set forth and claimed.

What I claim, and desire to secure by Letters Patent of the United States, is as follows:

1. A governor or automatic trip device having a centrifugally-actuated element, and automatic means for positively agitating the said element, to prevent sticking thereof, substantially as described.
2. The combination with a traveling belt, of a governor or automatic trip device comprising a wheel having contact with and driven by said belt, and a centrifugally-actuated tripping element pivoted to said wheel and having a part which is intermittently engaged with said belt, to positively agitate and prevent sticking of the said tripping element, substantially as described.
3. The combination with a traveling belt, of a governor or trip device comprising a wheel running in contact with said belt and driven thereby, a lever for normally restraining the action of a cooperating device, a lever-tripping cam mounted on a non-rotary support, and a centrifugally-actuated governor-lever pivoted to said wheel and engageable with said tripping-cam to move the same when the speed of said belt runs at other than a predetermined speed or speeds, substantially as described.
4. The combination with a traveling belt, of a governor or trip device comprising a wheel running in contact with and driven by said belt, a lever for normally restraining the action of a cooperating device, a lever-tripping cam and a centrifugally-actuated governor-lever having a projection for action on said cam and having a projection which is intermittently thrown into engagement with said belt, to positively vibrate or agitate said lever and prevent sticking thereof, substantially as described.
5. The combination with a traveling belt, of a pivoted support and a governor or tripping device carried by said support and involving a centrifugally-actuated governor-lever, hav-

ing a projection which, under each rotation of said wheel, is brought into contact with said belt to positively move or agitate said governor-lever and to prevent sticking thereof, substantially as described.

6. In mechanism of the character described, the combination with a traveling belt, of an oscillating support, a wheel mounted on said support and running in contact with said belt, an adjustable spring acting on said support and pressing said wheel into contact with said belt, a governor-lever pivoted to said wheel, and a device operated by the said governor-lever, substantially as described.

7. In mechanism of the character described, the combination with a traveling belt, of a governor involving a wheel, held in contact with and driven by said belt, a cam mounted on a non-rotary bearing at the axis of said wheel and subject to a governor-lever carried by said wheel, a lever subject to said cam, and a device actuated by the said lever when the speed of said belt falls below a predetermined point, substantially as described.

8. The combination with an elevator-leg, an elevator-belt, and a gate controlling an entrance-passage to said leg, of a gripping device normally holding the said gate in an opened position, a spring-pressed tripping-lever for action on said gripping device to release said gate, a lock-lever normally restraining said tripping-lever, a cam mounted on a non-rotary support and movable to release said lock-lever, a wheel running in contact with said elevator-belt, and a centrifugally-actuated governor-lever carried by said wheel, subject to a spring, and operating on said cam, substantially as described.

9. The combination with an elevator-leg, an elevator-belt, and a gate-controlling end inlet to said leg, of a rod for supporting said gate in an open position, an eccentric and cooperating anvil for holding said rod, said eccentric being movable and having a projection, a tripping-rod having a tripping-finger for engaging the projection of said eccentric, to release the same, and means for automatically rocking said trip-rod to move said eccentric and drop said gate, substantially as described.

In testimony whereof I affix my signature in presence of two witnesses.

JAMES B. SOULE.

Witnesses:

JOHN ENGLAND,
F. D. MERCHANT.