



(12) **EUROPEAN PATENT APPLICATION**

(88) Date of publication A3:  
**11.10.2006 Bulletin 2006/41**

(51) Int Cl.:  
**B27C 5/10 (2006.01) B25F 5/02 (2006.01)**  
**B25H 3/00 (2006.01)**

(43) Date of publication A2:  
**31.05.2006 Bulletin 2006/22**

(21) Application number: **06075381.1**

(22) Date of filing: **10.08.2001**

(84) Designated Contracting States:  
**DE GB**

(30) Priority: **11.08.2000 US 224852 P**

(62) Document number(s) of the earlier application(s) in accordance with Art. 76 EPC:  
**01306860.6 / 1 238 767**

(71) Applicant: **MILWAUKEE ELECTRIC TOOL CORPORATION**  
**Brookfield**  
**Wisconsin 53005 (US)**

(72) Inventors:  
• **McDonald, Randy**  
**Sussex**  
**Wisconsin (US)**  
• **Borchardt, Dale**  
**Wind Lake**  
**Wisconsin 53185 (US)**

- **Thorson, Troy**  
**Wakesha**  
**Wisconsin 53185 (US)**
- **Berg, Christopher**  
**Milwaukee**  
**Wisconsin 53222 (US)**
- **Holly, Jeffrey S.**  
**Menomonee Falls**  
**Wisconsin (US)**
- **Hessenberger, Jeffrey C.**  
**Neosho**  
**Wisconsin 53059 (US)**

(74) Representative: **Holmes, Matthew Peter et al**  
**MARKS & CLERK,**  
**Sussex House,**  
**83-85 Mosley Street**  
**Manchester M2 3LG (GB)**

(54) **Router**

(57) A router (20) including a base (24) for supporting the router on a work piece (W) surface, a motor housing (28) supported by the base (24), and a motor supported by the housing and operable to drive a tool element. The router also includes a hand grip (48) attachable to one of the base (24) and the housing (28). The hand grip (48) may be contoured to fit a hand of an operator and may be at least partially formed of an elastomeric material. The router (20) may also include a fixing assembly for fixing the housing (28) in a position relative to the base (24), the fixing assembly including a clamping member for applying a clamping force to the housing (28) to fix the housing in a position relative to the base (24), and an actuator for moving the clamping member. The router may also include an adjustment mechanism (224) for adjusting the position of the housing (28) relative to the base (24), the adjustment mechanism (224) including a coarse adjustment assembly for making relatively large changes in the position of the housing (28), and a fine adjustment assembly for making relatively small changes to the po-

sition of the housing (28). The adjustment mechanism (224) may be operated when the router (20) is supported in an inverted position below a work table. A router case having a removable molded base plate may be provided to support the router on a surface.

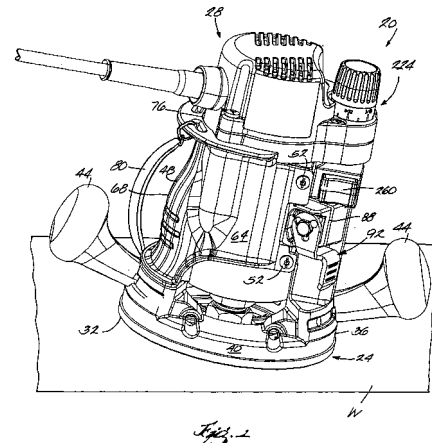



DOCUMENTS CONSIDERED TO BE RELEVANT			
Category	Citation of document with indication, where appropriate, of relevant passages	Relevant to claim	CLASSIFICATION OF THE APPLICATION (IPC)
Y	US 3 556 623 A (DAMIJONAITIS) 19 January 1971 (1971-01-19) * column 2, lines 6-13; figures 1-3 *	1,4-10, 13	INV. B27C5/10 B25F5/02 B25H3/00
Y	FR 2 333 990 A (DEVILLIERS) 1 July 1977 (1977-07-01) * page 1, lines 17-28 * * page 6, lines 4-7,15-18; figures 1,2,5 *	1,4-10, 13	
A	US 4 160 570 A (BRIDGES) 10 July 1979 (1979-07-10)  * column 3, lines 32-43; figure 1 *	1,3,4,6, 8,9,12, 13	
A	US 3 317 076 A (ENDERS) 2 May 1967 (1967-05-02) * column 2, lines 31-36,63-68; figures 1-5 *	1,4-7,9, 10,13	
-----			TECHNICAL FIELDS SEARCHED (IPC)
			B27C B25F B25H B23Q
<del>The present search report has been drawn up for all claims</del>			
Place of search		Date of completion of the search	Examiner
The Hague		17 August 2006	Matzdorf, U
CATEGORY OF CITED DOCUMENTS			
X : particularly relevant if taken alone Y : particularly relevant if combined with another document of the same category A : technological background O : non-written disclosure P : intermediate document		T : theory or principle underlying the invention E : earlier patent document, but published on, or after the filing date D : document cited in the application L : document cited for other reasons ..... & : member of the same patent family, corresponding document	

3  
EPO FORM 1503 03.82 (P04C01)

**ANNEX TO THE EUROPEAN SEARCH REPORT  
ON EUROPEAN PATENT APPLICATION NO.**

EP 06 07 5381

This annex lists the patent family members relating to the patent documents cited in the above-mentioned European search report. The members are as contained in the European Patent Office EDP file on The European Patent Office is in no way liable for these particulars which are merely given for the purpose of information.

17-08-2006

Patent document cited in search report		Publication date	Patent family member(s)	Publication date
US 3556623	A	19-01-1971	NONE	
-----				
FR 2333990	A	01-07-1977	NONE	
-----				
US 4160570	A	10-07-1979	NONE	
-----				
US 3317076	A	02-05-1967	NONE	
-----				

EPO FORM P0459

For more details about this annex : see Official Journal of the European Patent Office, No. 12/82