



(22) Date de dépôt/Filing Date: 2004/03/09  
 (41) Mise à la disp. pub./Open to Public Insp.: 2004/09/30  
 (45) Date de délivrance/Issue Date: 2013/05/07  
 (62) Demande originale/Original Application: 2 485 445  
 (30) Priorité/Priority: 2003/03/14 (US10/389,448)

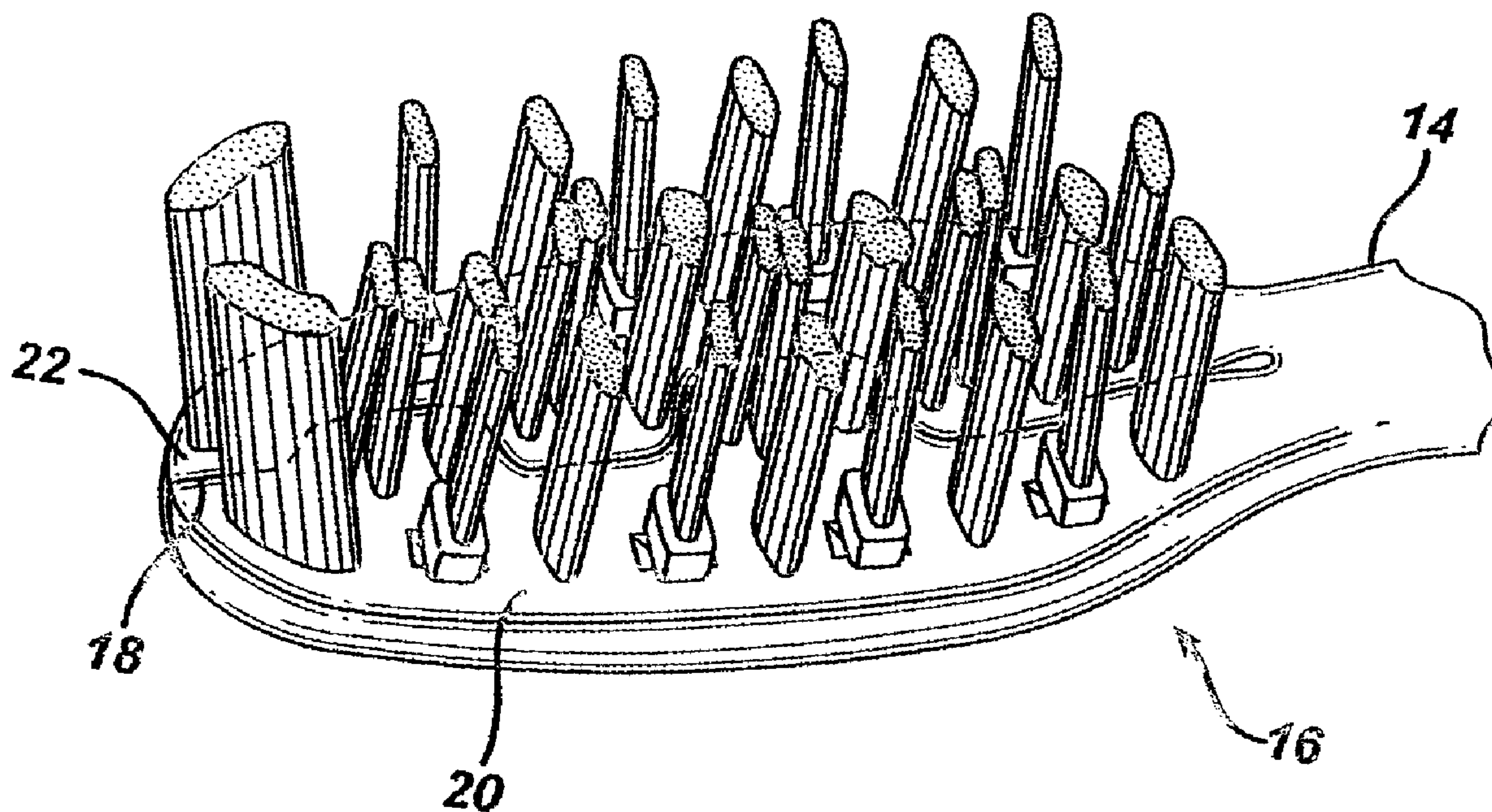
(51) Cl.Int./Int.Cl. *A46D 3/00* (2006.01),  
*A46B 9/04* (2006.01)

(72) Inventeurs/Inventors:  
 CLAIRE-ZIMMET, KAREN, US;  
 ZIMMET, HELGE, US;  
 DENG, JOANNA Q., DE;  
 MAJTHAN, RUDOLF, US;  
 HANS, RAINER, US;  
 BROWN, WILLIAM R., JR., US;  
 CHRISTMAN, THOMAS A., US;  
 ...

(73) Propriétaire/Owner:  
 THE GILLETTE COMPANY, US

(74) Agent: MBM INTELLECTUAL PROPERTY LAW LLP

(54) Titre : METHODE DE FABRICATION D'UNE TETE DE BROSSA A DENTS  
 (54) Title: METHOD OF MAKING A TOOTHBRUSH HEAD



(57) Abrégé/Abstract:

A method of making a toothbrush head having two distinct portions. The toothbrush head is molded with the two distinct portions being spaced a predetermined distance from each other. The head is removed from the mold and the head portions are moved toward each other while the part of the head where the two portions connect is heated then cooled such that the head portions will be spaced apart a distance less than when molded. Tooth cleaning elements may be secured to one of the head portions during the molding process.

(72) Inventeurs(suite)/Inventors(continued): DEPUYDT, JOSEPH A., US; DUFF, RONALD R., JR., US;  
MANGAN, EDWARD J., US; BRAUN, PHILIP M., US

**ABSTRACT**

A method of making a toothbrush head having two distinct portions. The toothbrush head is molded with the two distinct portions being spaced a predetermined distance from each other. The head is removed from the mold and the head portions are moved toward each other while the part of the head where the two portions connect is heated then cooled such that the head portions will be spaced apart a distance less than when molded. Tooth cleaning elements may be secured to one of the head portions during the molding process.

- 1 -

METHOD OF MAKING A TOOTHBRUSH HEAD

This application is a division of co-pending, commonly-owned Canadian Patent Application No. 2,485,445 filed March 9, 2004.

5 The invention relates generally to the field of oral care, and in particular to toothbrushes. More specifically, the invention relates to a toothbrush head having one or more pivoting tufts of bristles, the head having two portions that can move independent of each other.

A Japanese patent document having an application number of 3-312978 discloses a toothbrush having a multiplicity of tufts of nylon bristles. In a first  
10 embodiment shown in Figures 1, 2 and 3, a plurality of cylindrical recessed sections in the head are set orthogonally to the longitudinal axial direction of a shank and are formed at equal intervals. Column-shaped rotary bodies 5 are respectively contained in the recessed sections. On the peripheral surfaces of the rotary bodies 5, along the axial direction, projected strip sections 5a are formed, and they are set in a state that they are positioned at  
15 the opening sections of the recessed sections. At the opening sections of the recessed sections, contact surfaces to be positioned on both the sides are formed. At both the ends of the upper surfaces of the projected strip sections 5a, nylon bristles 6 are arranged to be vertically erected.

As shown in Figure 3, the arrangement described above allows bristles 6 to  
20 rotate during use of the brush. A problem with this brush is that two tufts of bristles are secured to each strip section 5a and thus must rotate in unison. As a result, an individual tuft of bristles cannot rotate independently of its "partner" tuft. The individual tuft may thus be prevented from achieving optimal penetration between two teeth during brushing because the partner tuft might contact the teeth in a different manner and interfere with  
25 rotation of the individual tuft.

Figures 4, 5 and 6 disclose a second embodiment in which each tuft of bristles is secured to the head by a ball and socket type arrangement. While this embodiment allows each tuft of bristles to swivel independent of the other tufts, it does have disadvantages. If a tuft of bristles is tilted out towards the side of the head and that  
30 tuft is positioned near the interface between the side and top surfaces of the teeth, chances are increased that the bristle tips will not even be in contact with the teeth during brushing. Further, the random orientation in which the tufts can end up after brushing detracts from the attractiveness of the brush.

- 2 -

The Japanese reference also discloses that the brush head is made of a unitary structure. As such, water cannot flow through any central portion of the brush head, thereby inhibiting the cleanability of the brush. Further, the unitary head structure does not allow different portions of the head to move independently of each other.

5 Accordingly, the bristle tufts extending from the tuft cannot accommodate the varying tooth surfaces as well as a brush in which the head has two or more portions that can move or flex independent of each other.

The present invention is directed to overcoming one or more of the problems set forth above. Briefly summarized, according to one aspect of the present  
10 invention, a toothbrush head has a tooth cleaning element extending from the head. The head is divided into at least two portions which can be moved independent of each other. The tooth cleaning element is rotatable relative to that portion of the head from which it extends.

According to another aspect of the invention, a tooth cleaning element  
15 includes one or more tooth cleaners, a base support, and an anchor pivot. One end of the one or more tooth cleaners is secured to a first end of the base support. One end of the anchor pivot is secured to a second end of the base support. The anchor portion has a larger section further from the base support than a smaller section of the anchor portion.

In accordance with a third aspect of the invention, a method of making a  
20 toothbrush head includes molding a plastic toothbrush head in a mold. The head has two distinct portions which are spaced a predetermined distance from each other. The head is removed from the mold. At least that part of the head where the two head portions connect is heated. The two head portions are moved towards each other. At least that  
25 part of the head where the two head portions connect is cooled such that the two head portions will now remain in positions where they will be spaced apart a distance which is less than the predetermined distance.

According to a fourth aspect of the invention, a method of making a  
toothbrush head includes molding a plastic toothbrush head in a mold. The head has at least one hole therein which extends all the way through the head. The head is removed  
30 from the mold. A tooth cleaning element is inserted into the hole

These and other aspects, objects, features and advantages of the present

- 3 -

invention will be more clearly understood and appreciated from a review of the following detailed description of the preferred embodiments and appended claims, and by reference to the accompanying drawings.

FIG. 1 is a perspective view of the toothbrush head;

5 FIG. 2 is a top view of the head of Fig. 1;

FIG. 3 is a side view of the head of Fig. 1;

FIG. 4 is a bottom view of the head of Fig. 1;

FIG. 5 is a side view of the head of Fig. 1 showing one of the head portions flexing;

10 FIG. 6 is a top view of the head of Fig. 1 with the two head portions separated from each other;

FIG. 7 is a top view of the head of Fig. 1 after the head portions have been positioned closer to each other;

FIG. 8 is a front view of a pivoting tuft taken along the lines 8-8 of Fig. 13;

15 FIG. 9 is a side view of the pivoting tuft of Fig. 8 taken along lines 9-9;

FIG. 10 is a top view of one of the holes in the head for receiving the pivoting tuft (see Fig. 6);

FIG. 11 is a sectional view of Fig. 10 taken along lines 11-11;

FIG. 12 is a sectional view of Fig. 10 taken along lines 12-12;

20 FIG. 13 is a side view of the head of Fig. 1 (a portion is removed to facilitate viewing) and a pivoting tuft prior to insertion into the head;

FIG. 14 is a side view of the head of Fig. 1 (a portion is removed to facilitate viewing) and a pivoting tuft after insertion into the head;

FIG. 15 is a side view of the pivoting tuft showing its motion;

25 FIGS. 16A-C are sectional views of Fig. 15 taken along the lines 16A-C-16A-C;

FIG. 17 is a perspective view of a tooth cleaner in the form of a ribbed fin; and

FIG. 18 is a side view of the ribbed fin of Fig. 17.

30 Beginning with FIGS. 1-5, there is shown a toothbrush head 16 which extends from a neck 14 which extends from a handle (not shown) to form a toothbrush.

- 4 -

The type of handle is not germane to the present invention. The head and handle are preferably made of polypropylene. The head has a serpentine split 18 which divides the head into two portions 20 and 22. An end of the split 18 near neck 14 is preferably circular in shape (see Fig. 2). As shown in Fig. 5, the split in the head allows portions 20 and 22 to flex or move independent of each other during use of the toothbrush, thus facilitating cleaning of the teeth.

Split 18 can also be defined as an opening in the head between head portions 20 and 22. This opening allows water to flow through the head, thereby enhancing cleaning of the top head surface which typically gets caked with toothpaste in spite of efforts to rinse the head clean.

Head portion 20 includes a projecting part 24 which fits (at least partially) into a recess 26 (see Fig. 6) defined by portion 22. Projecting part 24 has several tufts of bristles extending from it (to be described in further detail below) and is surrounded on three sides by head portion 22.

Referring now to Figs. 2 and 3, each of the tufts of bristles on head 16 will be described. A first pair of tufts 28 are located towards the free end of the head, one on each head portion 20, 22. Each tuft has bristles (tooth cleaners) which preferably are each made of polybutylene-terephthalate (PBT) and have a diameter of .007 inches. The shortest bristles in tuft 28 have a length of .420 inches with the remaining bristles increasing in length steadily to a tip of the tuft. Each tuft tilts away from the handle by an angle of preferably about 12 degrees relative to that portion of the surface of the head from which it projects. As shown in Fig. 2, tufts 28 have a larger cross-section than any other tuft on the head.

A second group of tufts are pivoting tufts 30 (the only tufts on the head which are rotatable). There are four tufts 30 on each head portion 20, 22 which are located towards the outside of the head. Each tuft 30 can pivot up to about 15 degrees to either side of a vertical position on the head, more preferably being able to pivot up to about 8 degrees to either side of a vertical position on the head. The pivoting of tufts 30 is roughly towards or away from neck 14. Each tuft 30 includes a base support 32 made of polypropylene. The bristles are made of polyamid 6.12, have a diameter of .008 inches and extend .420 inches above the base support.

A third group of tufts 34 extend perpendicular to the head. There are four tufts 34 on each head portion 20, 22 which alternate with tufts 30. When viewed from the top (Fig. 2) the tufts are oval in shape (similar to tufts 30 but larger). In other words, the tufts 34 and 30 have oval shaped cross-sections. Each tuft 34 has bristles which are made of polyamid 6.12, have a diameter of .006 inches and extend above the head by about .385 inches.

A fourth group of tufts 36 are located towards the inside of the head. There are two such tufts on each head portion 20, 22. Each tuft 36 extends perpendicular to the head. The bristles of tuft 36 have a diameter of .006 inches, are made of polyamid 6.12 and rise about .360 inches above the head.

A fifth and final group of tufts 38 are also located towards the inside of the head (away from a perimeter 21 of the head). There are 4 pairs of tufts 38. In each pair one tuft is closer to neck 14 than the other tuft. In each pair of tufts 38, (a) a base of one tuft is closer to a first side of the head and this one tuft leans towards a second side of the head, and (b) a base of the other tuft is closer to the second side of the head and this other tuft leans towards the first side of the head. As such, the tufts in each pair lean across each other. The angle of tilt towards the side of the head is about five degrees. Each tuft 38 has bristles which are made of PBT, have a bristle diameter of about .007 inches and extend about .460 inches above head 16. Each tuft 38 has an oval cross-section with a long dimension of the oval being oriented in the direction of tilt.

The bristles used on the head can be crimped (see U.S. Patent 6,058,541) or notched (see U.S. Patent 6,018,840). Other types of tooth cleaners besides bristles can be used. For example, a tuft of bristles could be replaced by an elastomeric fin

Turning now to Fig. 6, a description will now be provided as to how the toothbrush (head) is made. In a first step, the head, neck and handle of the toothbrush are injection molded in a mold. During this injection molding step, tufts 28, 34, 36 and 38 are secured in the head by a hot-tufting process. Hot-tufting processes are notoriously well known by those skilled in the art (see e.g. U.S. Patents 4,635,313; and 6,361,120; British patent application 2,330,791; and European patent application 676,268 A1).

Briefly, hot-tufting involves presenting ends of a multiplicity of groups of

- 6 -

plastic filaments into a mold. Each group of filament ends inside the mold is optionally melted into a blob. Each filament group is cut to a desired length (either before or after being introduced into the mold) to form a tuft of bristles. The mold is closed and molten plastic is injected into the mold. When the plastic solidifies, it locks one end of the tufts of bristles into the head of the toothbrush.

It can be seen in Fig. 6 that the opening 18 between head portions 20 and 22 is much wider at this point than in the heads final form (see Fig. 2). In other words, head portions 20 and 22 are spaced a predetermined distance (preferably at least about 1mm) from each other. Further, through holes 40 are created during the molding step for receiving pivoting tufts 30 at a later point in the manufacturing process. Holes 40 will be described in greater detail below.

With reference to Fig. 7, after the toothbrush is removed from the mold, heat 42 is applied to the head near the neck and to part of the neck (hereinafter the neck). The heat can be applied in a number of ways including hot air, radiant heating, ultrasonic or convection (e.g. hot oil) heating. Here the heat is shown being applied to the sides of the neck. It is preferable to apply the heat to the top and bottom surface of the neck. The heat brings the plastic up to 1.0 – 1.12 times its glass transition temperature (when temperatures are measured in the Kelvin scale). The plastic should not be heated above 1.12 times its glass transition temperature in order to avoid damaging the plastic. More preferably, the plastic is heated to about 1.03 – 1.06 times its glass transition temperature (measured in degrees Kelvin). The glass transition temperature for polypropylene is about 100 degrees centigrade whereas the glass transition temperature for copolyester and polyurethane is about 65 degrees centigrade.

Pressure 44 is then applied to head portions 20, 22 to move the portions towards each other. Once head portions 20, 22 are in the position shown in Fig. 2, the heated portion of the head/neck is cooled by, for example, exposing the heated portion to a cold gas or liquid. If room temperature air is used to cool the neck, such air should be applied for about 20-25 seconds. This has the effect of forming the two head portions into their final positions.

In order to achieve short process times, the highest temperature heat source which will not damage the plastic should be used. If too hot a heat source is used and/or

- 7 -

if the heat is applied for too long, the plastic can be damaged. If the heat source is not hot enough, the process will take too long and/or head portions 20, 22 will not remain in their final desired positions. If the head/neck are made of polypropylene and hot air is used to heat the neck, (a) the heated air should be at a temperature of about 170 degrees centigrade and should be applied to the neck for about 70 seconds, (b) the polypropylene should be raised to a temperature of about 140 degrees centigrade, and (c) a nozzle which applies the hot air to the neck should be about 10mm from the neck.

If copolyester or polyurethane is used as the material for the head neck, (a) the heated air should be at a temperature of 250 degrees centigrade and should be applied to the neck for about 10 seconds, (b) the material should be raised to a temperature of preferably 95-100 degrees centigrade, and (c) a nozzle which applies the hot air to the neck should be about 15-20mm from the neck.

Heating the respective materials above for the time indicated allows the material to be softened and mechanically bent into its final form. Exceeding the heating times above could cause the material to overheat and become damaged.

Turning to Figs. 8 and 9, each pivoting tuft 30 has a multiplicity of bristles 46, a base support 48 and an anchor pivot 50. The bristles are secured to and extend from a first end 52 of the base support while a first end 54 of the anchor pivot extends from a second end 56 of the base support. The base support and anchor pivot are preferably a unitary structure made of the same material. Anchor pivot 50 includes a first portion 58 near the first end 54 and a second portion 60 near a second end 62 of the anchor pivot. First portion 58 is smaller in an X and Y dimension than second portion 60. Base support 48 is larger in an X and Y dimension than second portion 60 of the anchor support. Second portion 60 includes a pair of lips 63. The anchor pivot defines an opening 64 therethrough.

Tuft 30 can also be made by a hot-tufting type process as described above. Instead of injecting plastic into the mold to form a toothbrush handle, neck and head, the plastic is injected into a mold to form base support 48 and anchor pivot 50, capturing bristles 46 when the injected plastic cools.

With reference to Figs. 10-12, through holes 40 (Fig. 6) will now be described. Each hole 40 extends from a top surface 66 of the brush head through a

- 8 -

bottom surface 68. Hole 40 includes first and second portions 70 and 72. Portion 72 is substantially a parallelepiped except that some of its lower section is rounded off (see Fig. 11). Portion 70 is also substantially a parallelepiped except that two of its sides are flared to the sides by about 15 degrees (see Fig. 12). Hole portion 72 is longer in a dimension A than hole portion 70 (Fig. 11). Hole portion 70 has about the same width in a dimension B as hole portion 72 where hole portions 70 and 72 meet (Fig. 12). Dimensions A and B are substantially perpendicular to each other in this embodiment. A pair of lips 73 are defined by this arrangement.

Turning now to Figs. 13-16, the insertion of pivoting tufts 30 into holes 40 will be described. A tuft 30 is positioned over a hole 40 with end 62 of anchor pivot 50 facing the hole (Fig. 13). As shown in Figs. 16A-C, tuft 30 is moved towards hole 40 until end 62 starts to enter the hole (Fig. 16A). Tuft 30 is then pressed into the hole causing sides of hole portion 70 to squeeze second portion 60 of the anchor pivot. Accordingly, anchor pivot 50 collapses causing opening 64 to become temporarily smaller. Tuft 30 is then pushed all the way into hole 40 (Fig. 16C) at which point the resilient plastic anchor pivot springs back to its form shown in Fig. 16A. This paragraph describes a snap-fit retention of tuft 30 to the head.

Referring to Fig. 16C, base support 48 is longer in the A dimension than hole portion 70 and thus prevents tuft 30 from being pressed further into hole 40. Second portion 60 is also longer in the A dimension than hole portion 70 and so prevents tuft 30 from moving back out of hole 40. This is due to the fact that lips 63 (Fig. 8) engage lips 73 (Fig. 11). This arrangement also prevents tuft 30 from rotating about the long axis of the bristles.

As shown in Fig. 15, tuft 30 pivots when it is engaged by, for example, portions of the oral cavity during brushing. Preferably each tuft 30 can pivot up to about 15 degrees to either side of a position perpendicular to surface 66.

Turning to Figs. 17 and 18, another type of tooth cleaning element in the form of a fin 80 is disclosed. Each fin is supported by a base support 48 and an anchor pivot 50 (both not shown) as described above, allowing the fin to pivot on the brush head. Alternatively, a fin can be securely affixed to the head so that it does not pivot. The fin is created of a thermoplastic elastomer (TPE) by an injection molding process. In this

- 9 -

embodiment, a textured surface is provided by a series of ribs 82. These ribs enhance cleaning of the oral cavity. The ribs are formed by injection molding a TPE over the fin. The ribs are preferably softer than the fin. Alternative textured surfaces (e.g. dimples) can be used in place of the ribs.

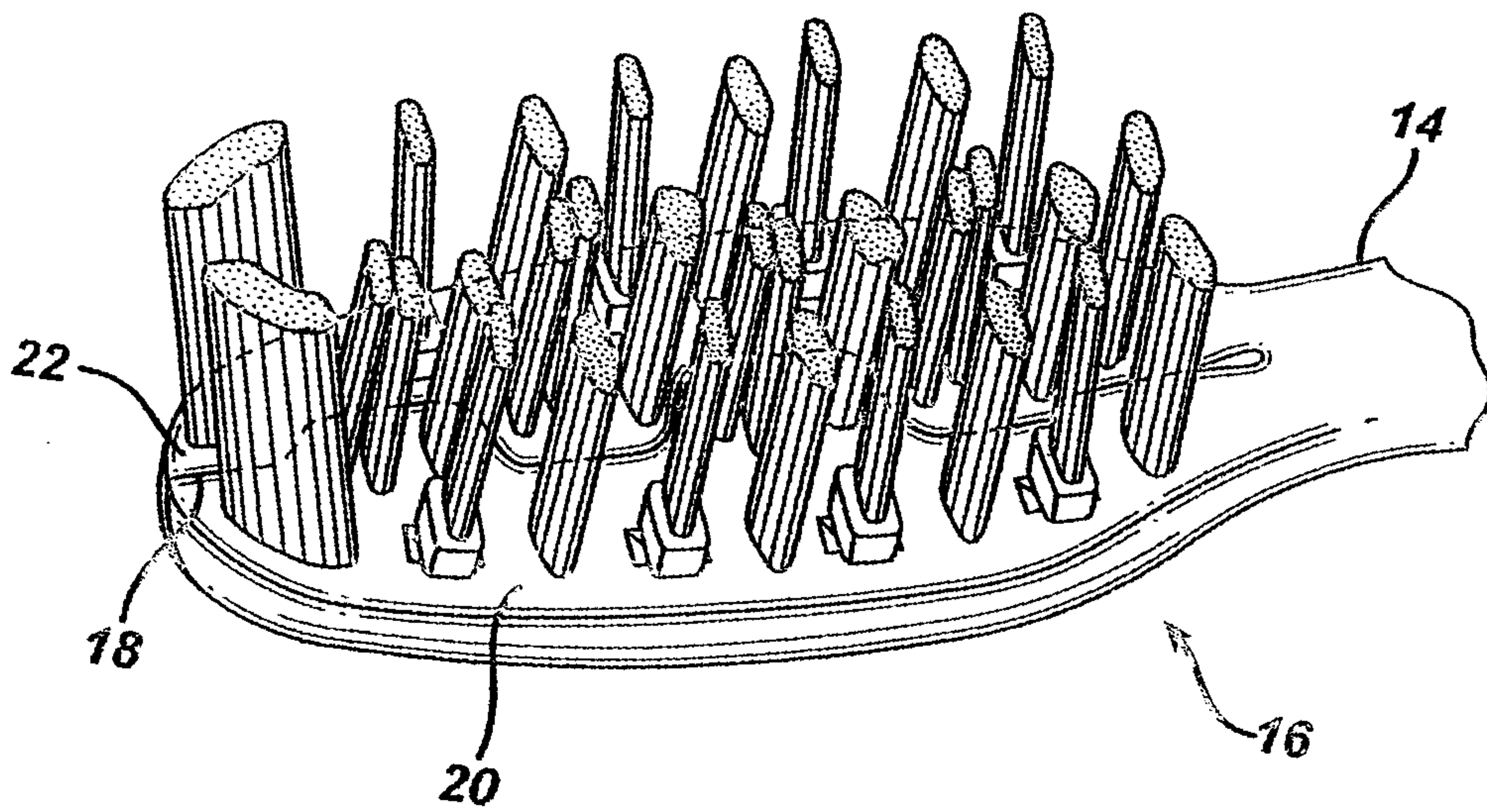
5                   As shown in Fig. 18, the fin has a width of preferably about .030 inches. The long dimension of the fin above the base support is preferably .420 inches. A tip 84 of fin 80 has a width of preferably .007 inches. The distance from the base of the ribs to tip 84 is about .168 inches whereas the distance from the top of the ribs to the tip is about .079 inches. The top of the ribs have a width of about .035 inches. The ribs (textured  
10 surface) preferably extend about 2-12 mil away from said fin.

**THE EMBODIMENTS OF THE INVENTION FOR WHICH AN EXCLUSIVE PROPERTY OR PRIVILEGE IS CLAIMED ARE DEFINED AS FOLLOWS:**

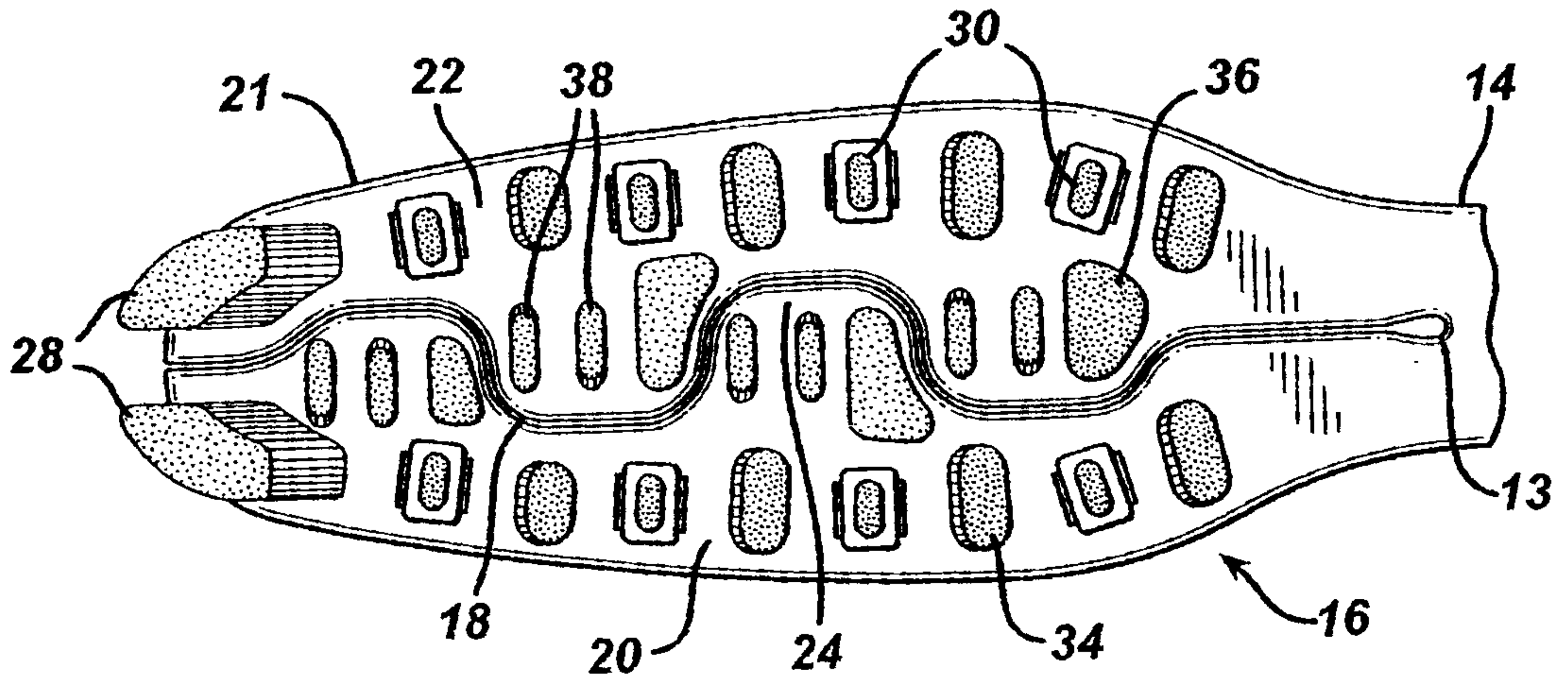
1. A method of making a toothbrush head, comprising the steps of molding a plastic toothbrush head in a mold, the head having two distinct portions, wherein opposing edges of the portions are spaced a predetermined distance from each other, removing the head from the mold, moving the opposing edges of the two head portions toward each other, heating at least that part of the head where the two head portions connect, and cooling at least that part of the head where the two head portions connect such that the opposing edges of the two head portions will now remain in positions where they will be spaced apart a distance which is less than the predetermined distance, wherein the molding step is effective to secure a tooth cleaning element to one of the two head portions.
2. The method of claim 1, wherein the tooth cleaning element is a tuft of one or more bristles.
3. The method of claim 1, wherein the molding step is effective to secure at least one or more tooth cleaning elements to each of the two head portions.
4. The method of claim 1, wherein the molding step is effective to mold a hole into one of the two head portions, the hole extending all the way through the head portion.
5. The method of claim 4, further comprising the step of inserting a tooth cleaning element into the hole.
6. The method of claim 5, wherein the hole extends from a top surface of the head from which one or more tooth cleaning elements will project, to a bottom surface of the head opposite the top surface.

7. The method of claim 6, wherein the hole has a first portion near the top surface, and wherein the hole has a second portion near the bottom surface, the length of the first hole portion being shorter than the length of the second hole portion.
8. The method of claim 1, wherein the step of heating at least that part of the head includes the step of heating the head part to 1.00-1.12 times the plastic's glass transition temperature.
9. The method of claim 1, wherein the cooling at least part of the head includes the step of blowing air on to the head part for 20-25 seconds.
10. The method of claim 6, wherein inserting a tooth cleaning element into the hole further includes the step of providing a tooth cleaning element having one or more tooth cleaners, a base support and an anchor pivot, one end of the one or more tooth cleaners being secured to a first end of the base support, and one end of the anchor pivot being secured to a second end of the base support.
11. The method of claim 10, further comprising the step of inserting the anchor pivot into the hole such that the anchor pivot resides in the second hole portion and the base support is adjacent to the top surface.
12. The method of claim 4, further comprising the step of snap-fitting a tooth cleaning element into the hole.

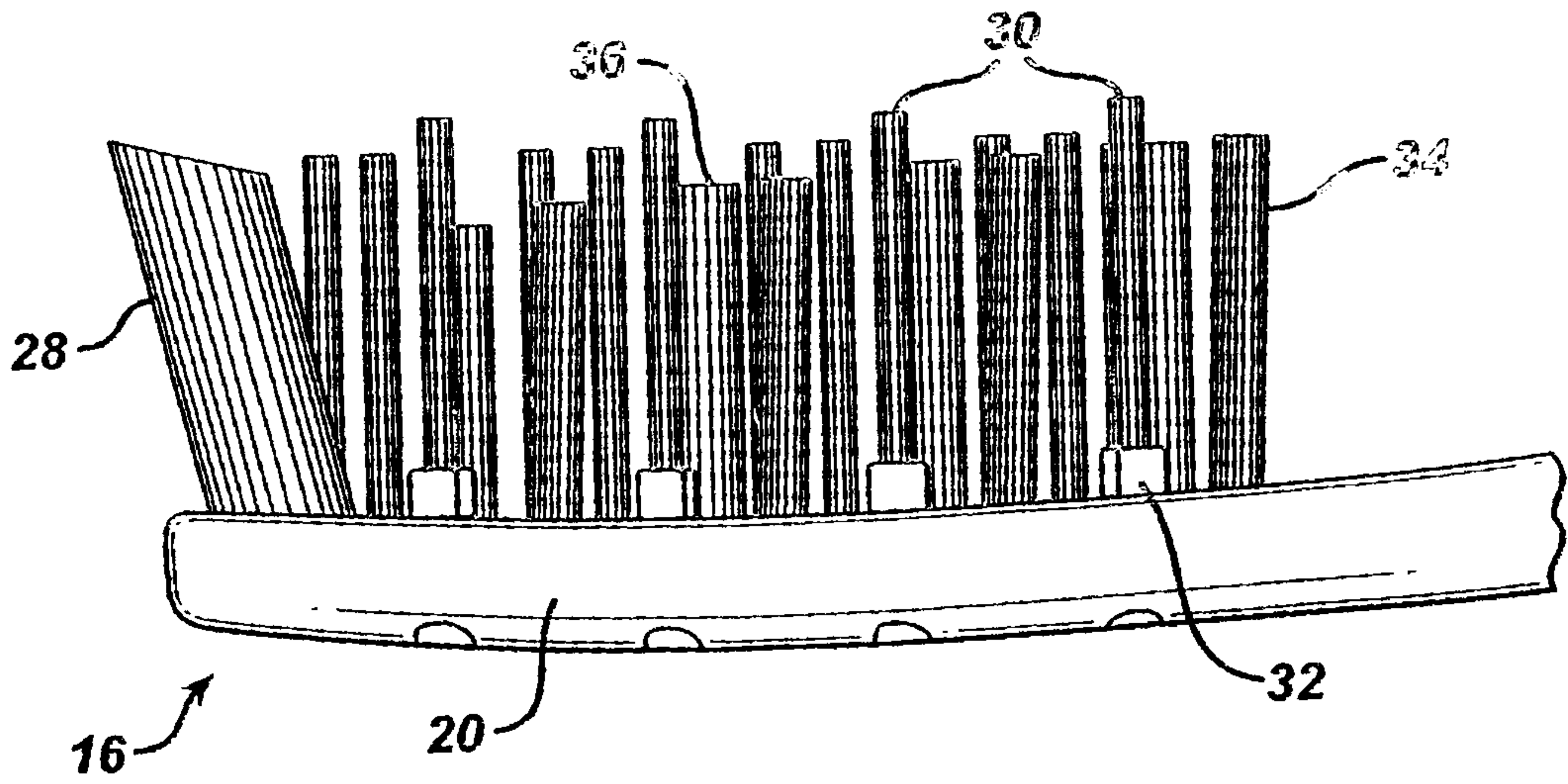
**FIG. 1**



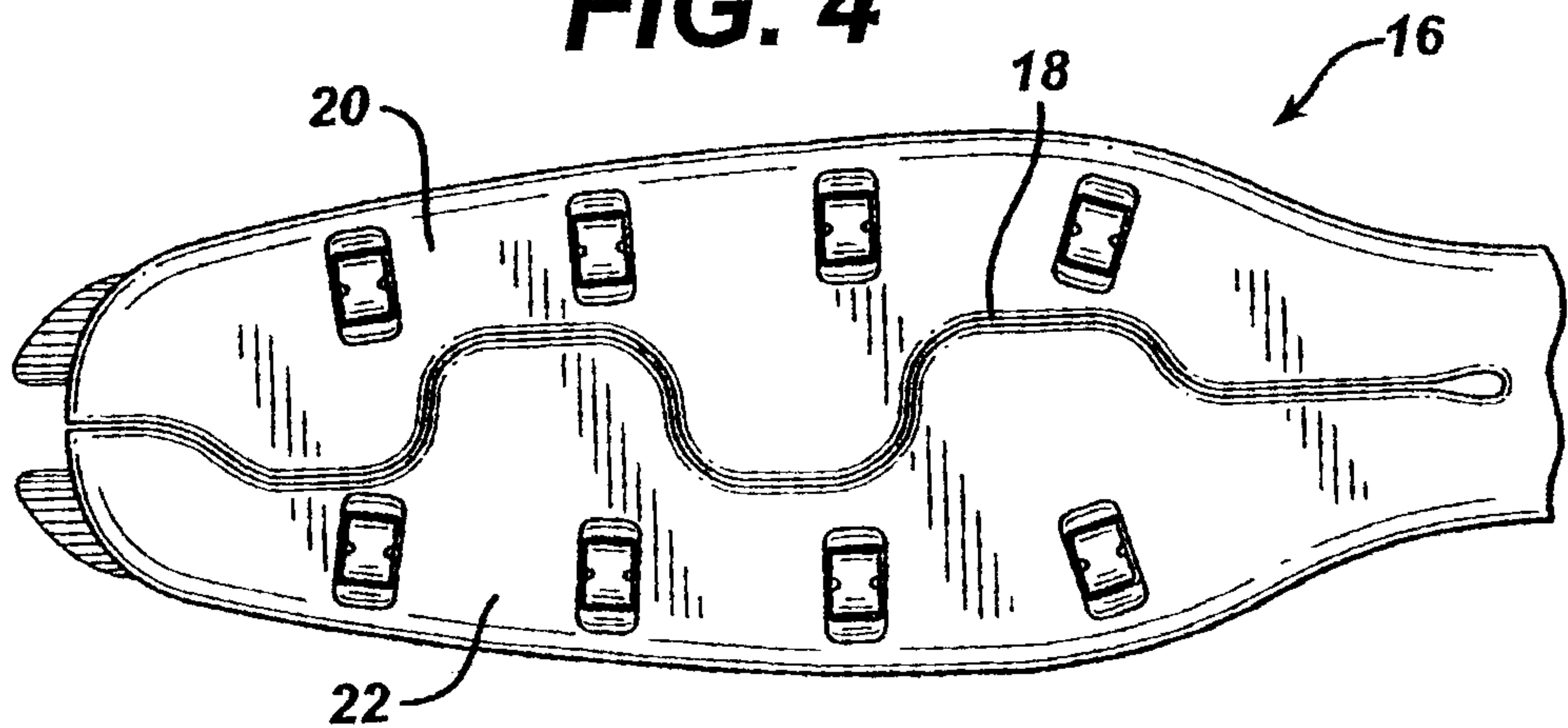
**FIG. 2**



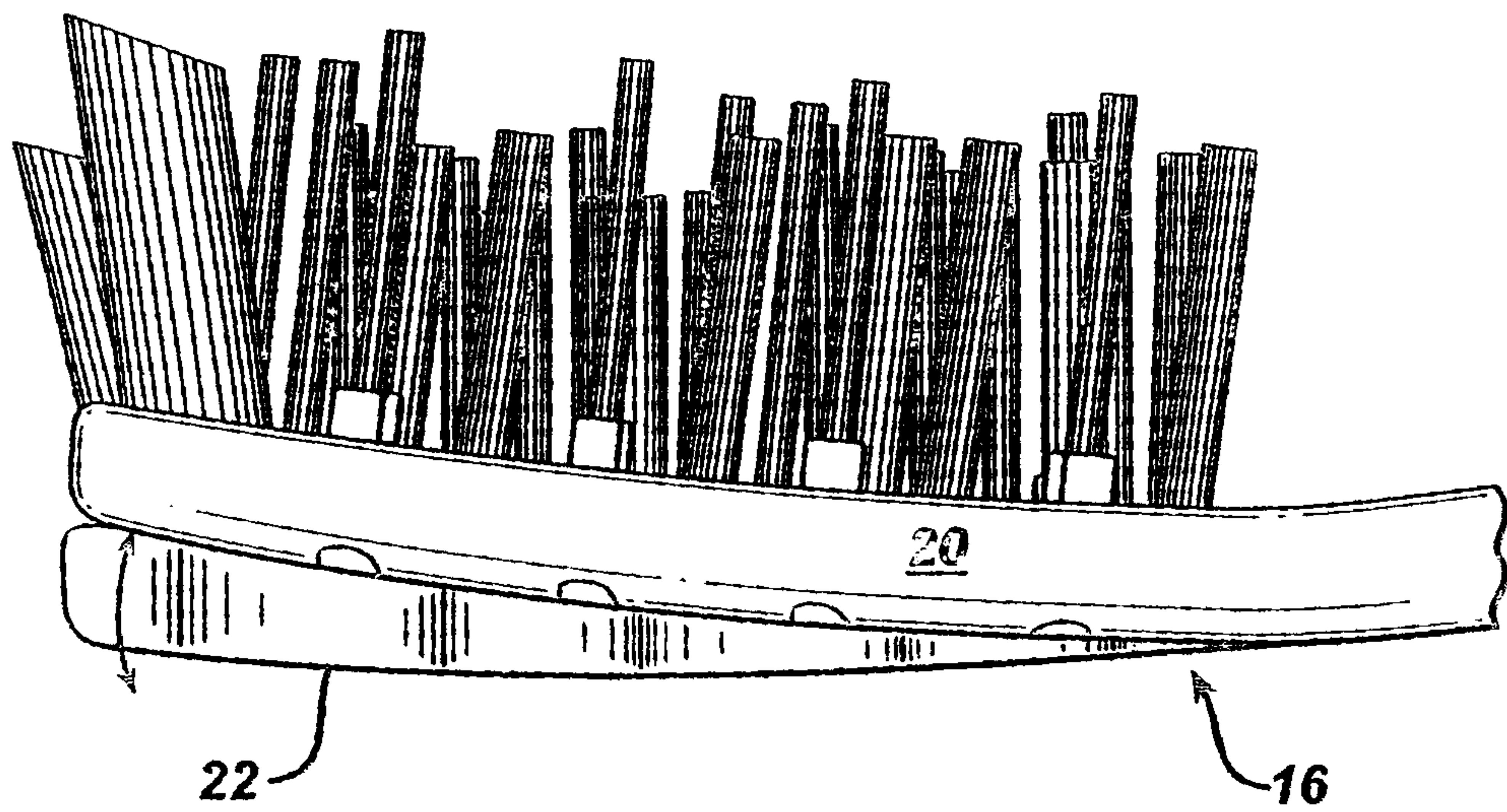
**FIG. 3**



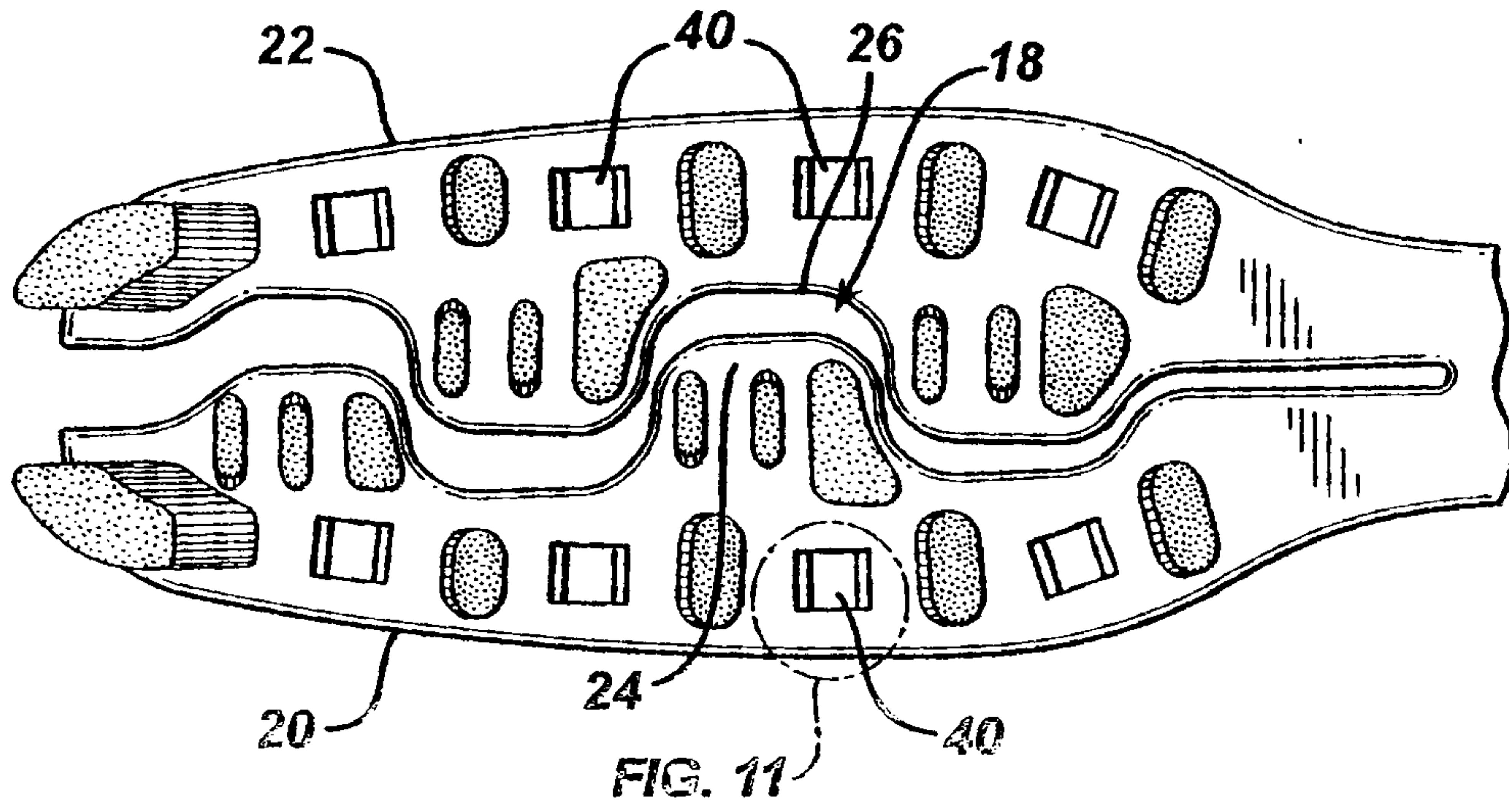
**FIG. 4**



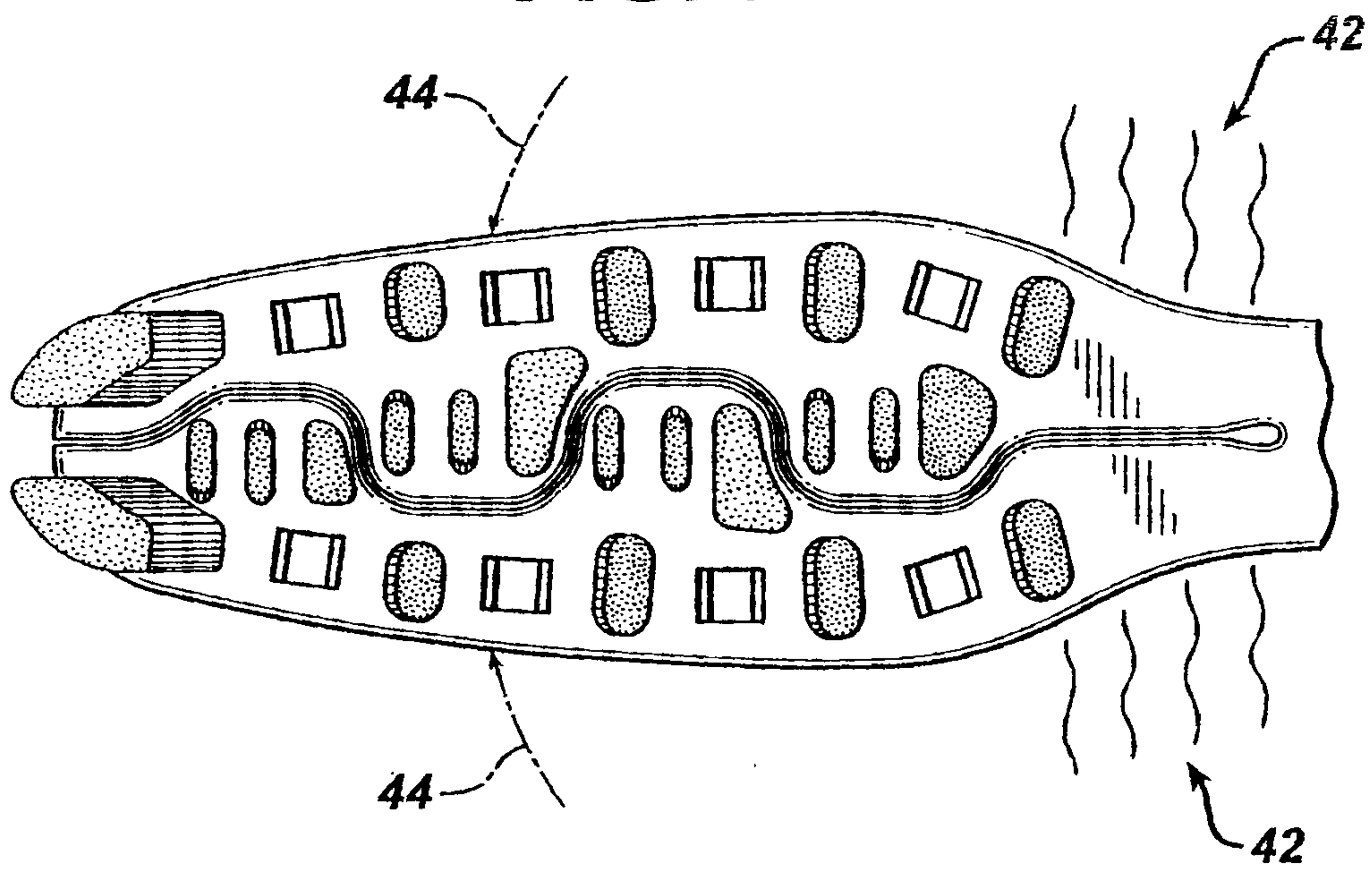
**FIG. 5**



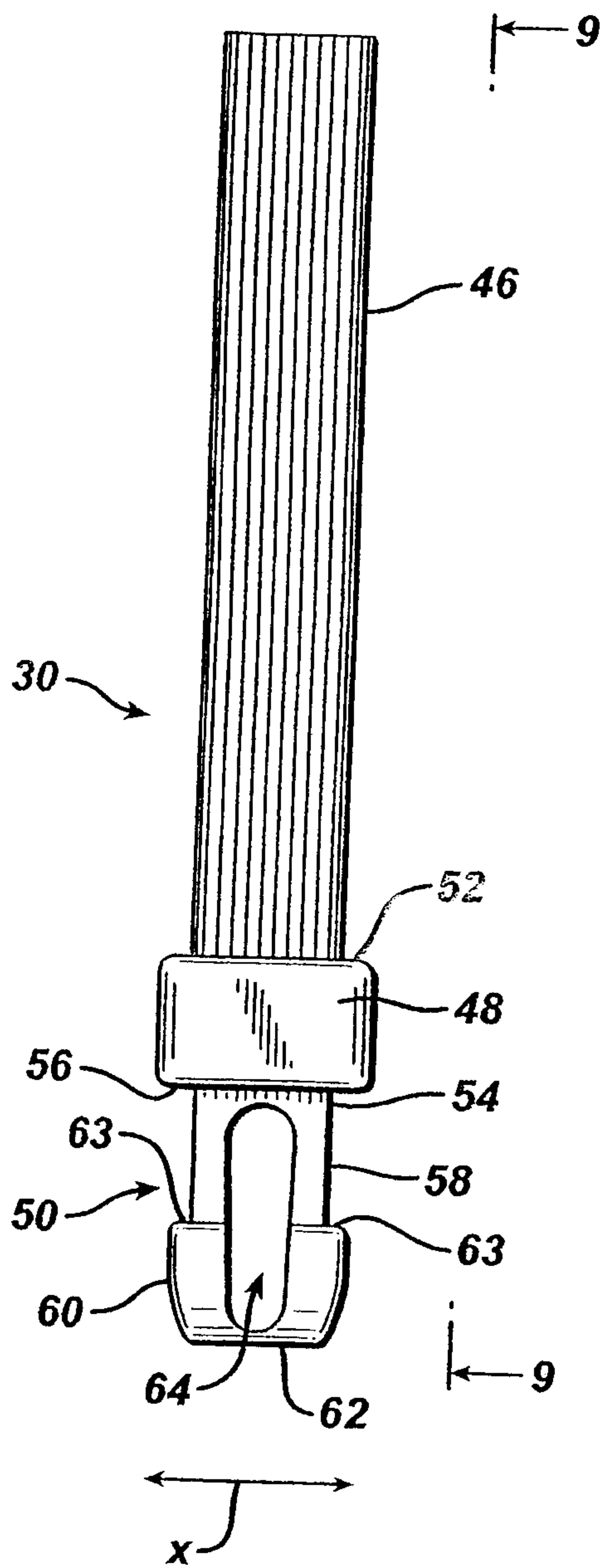
**FIG. 6**



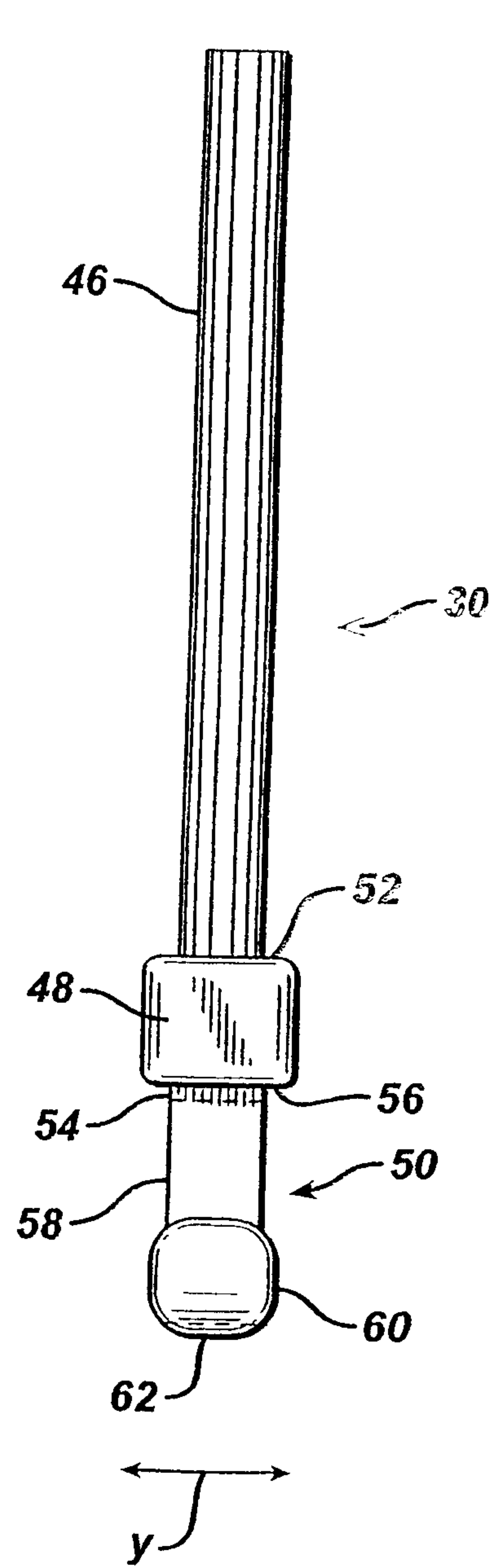
**FIG. 7**



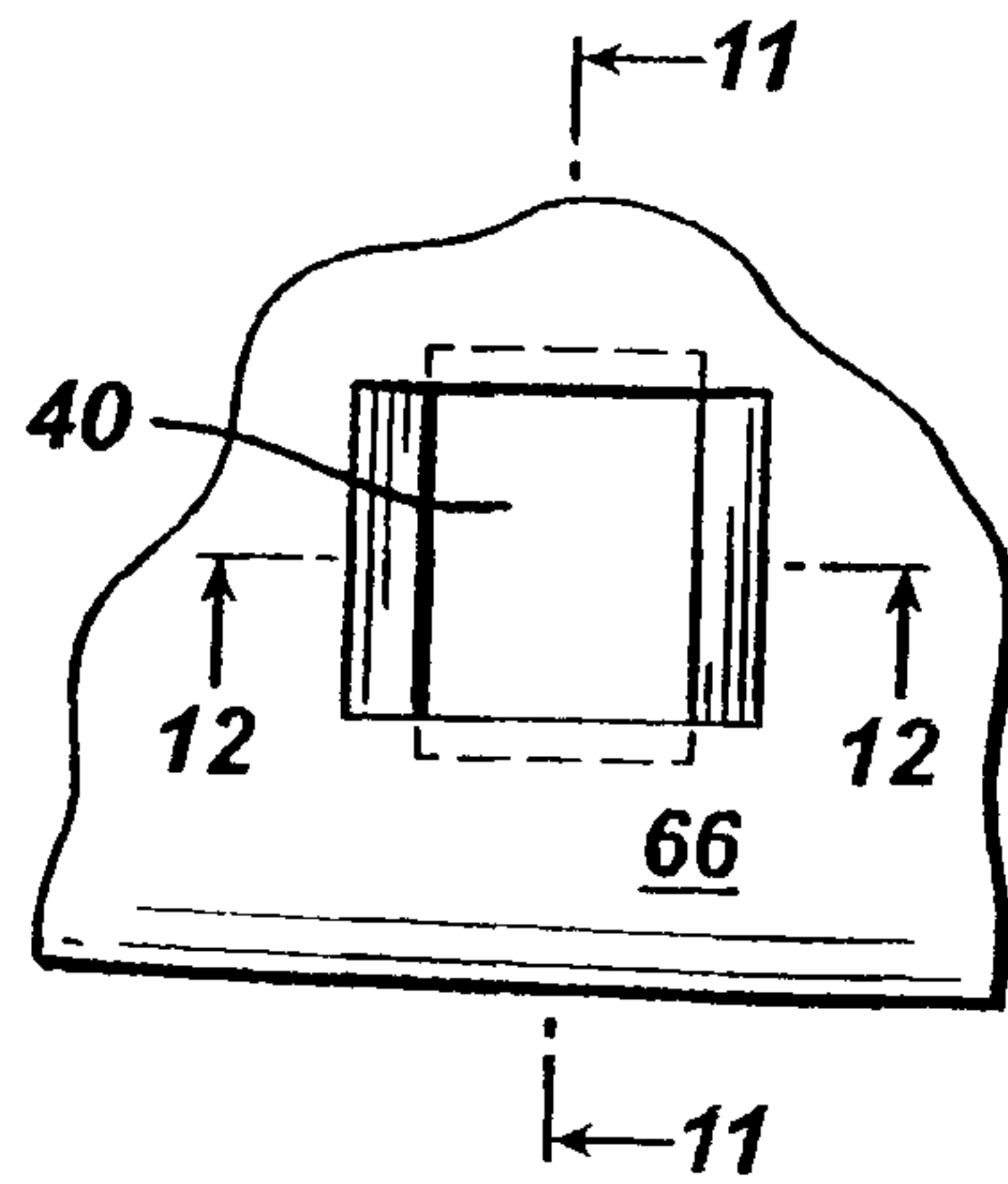
**FIG. 8**



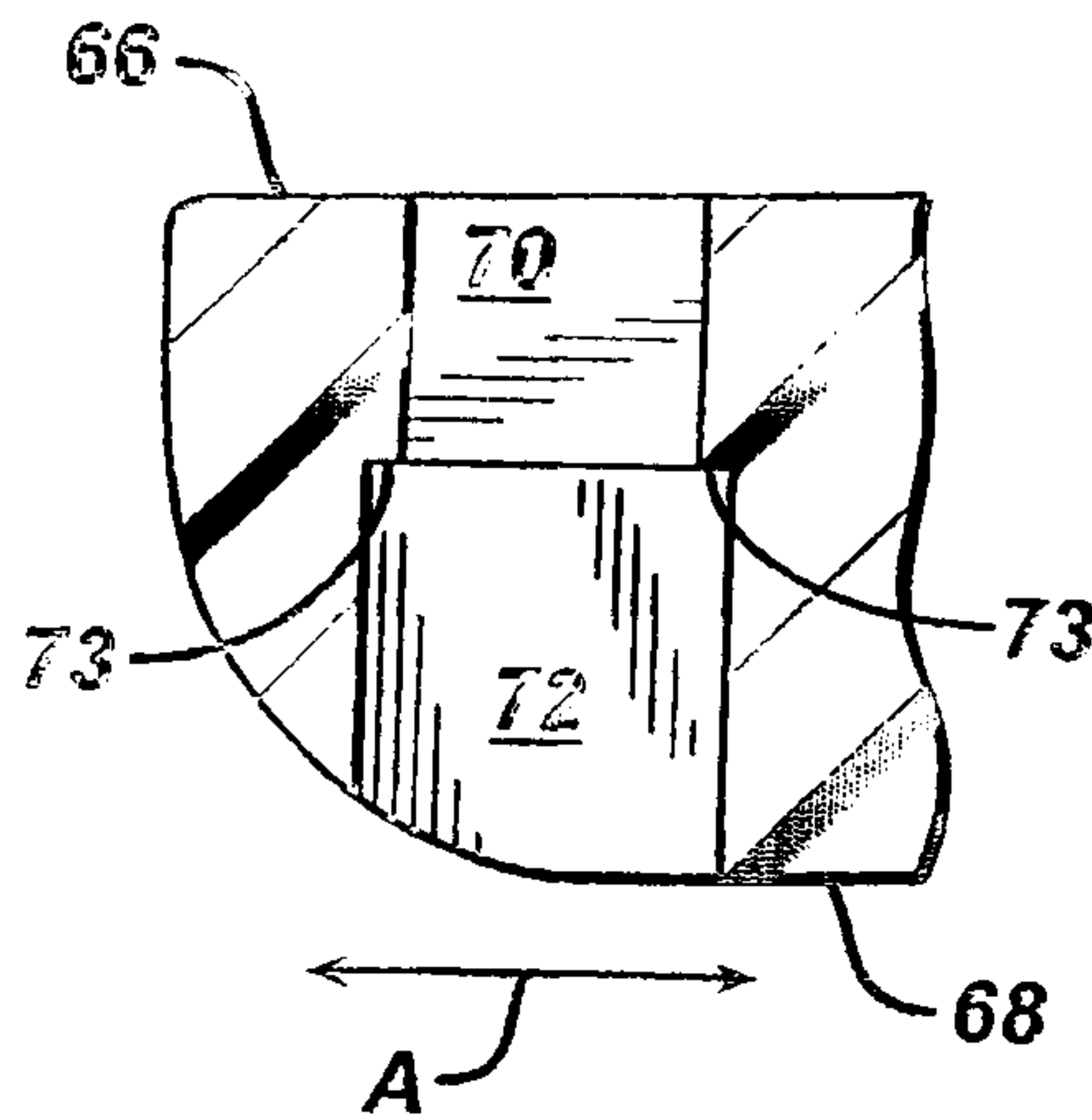
**FIG. 9**



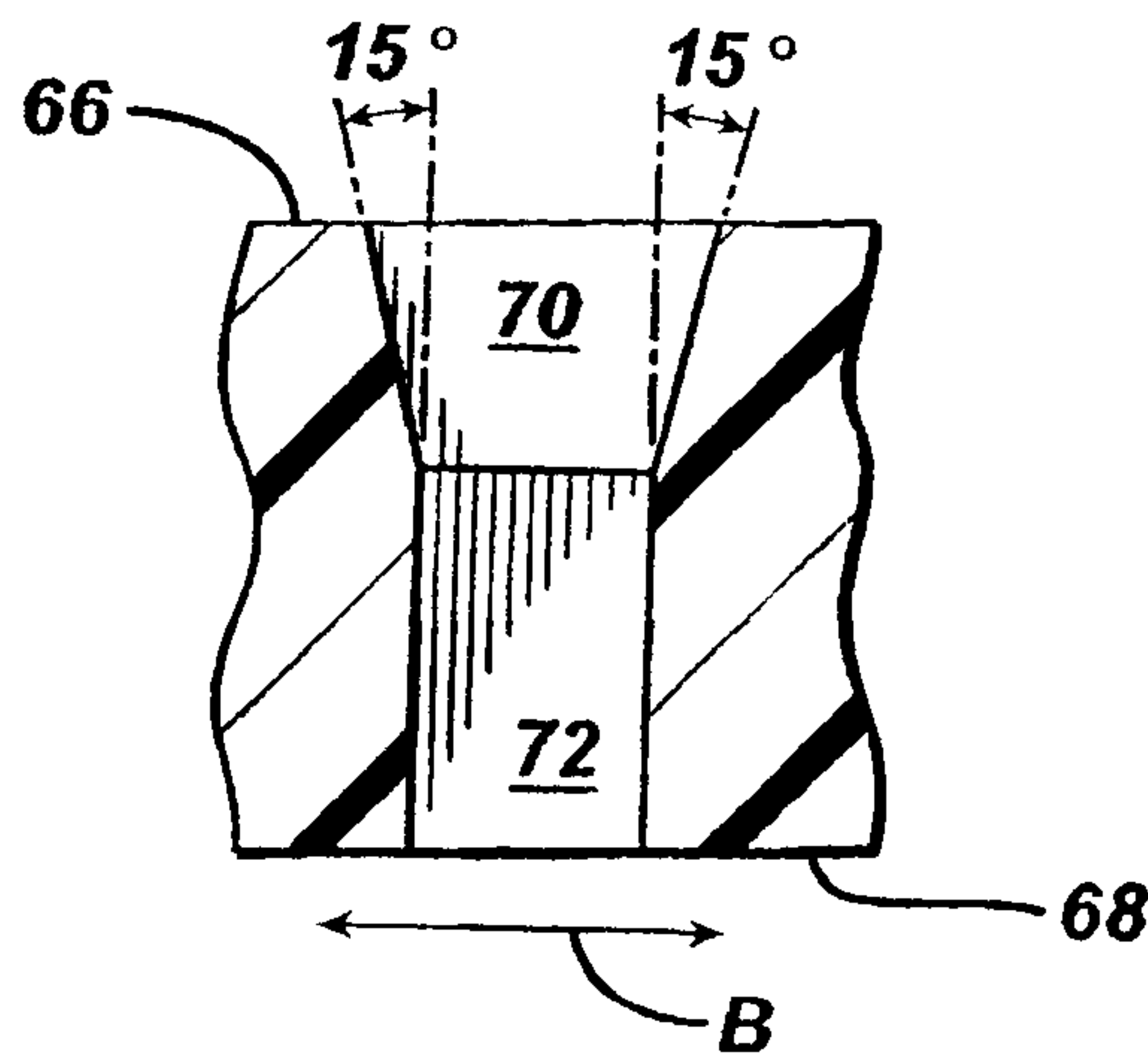
**FIG. 10**



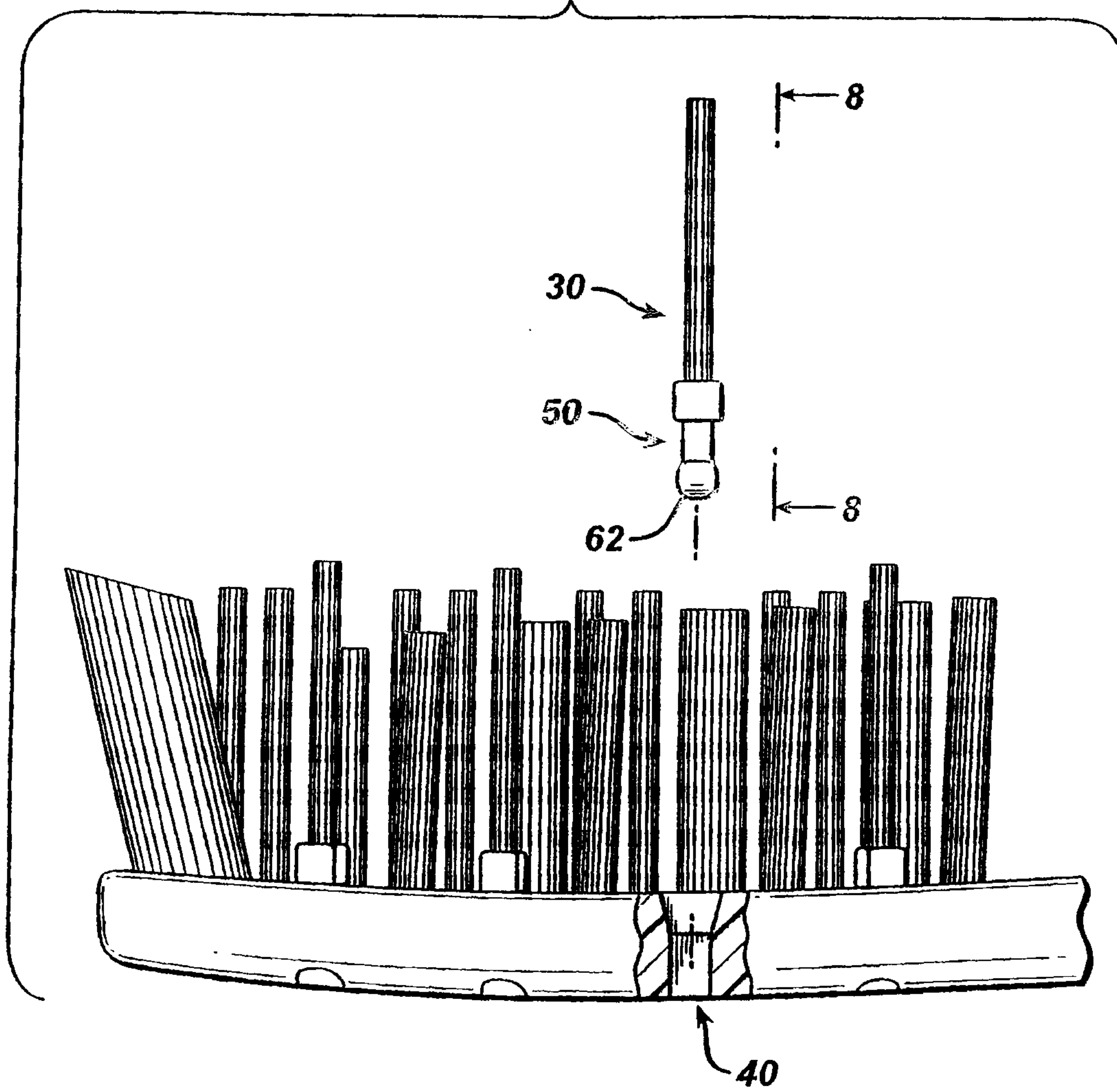
**FIG. 11**



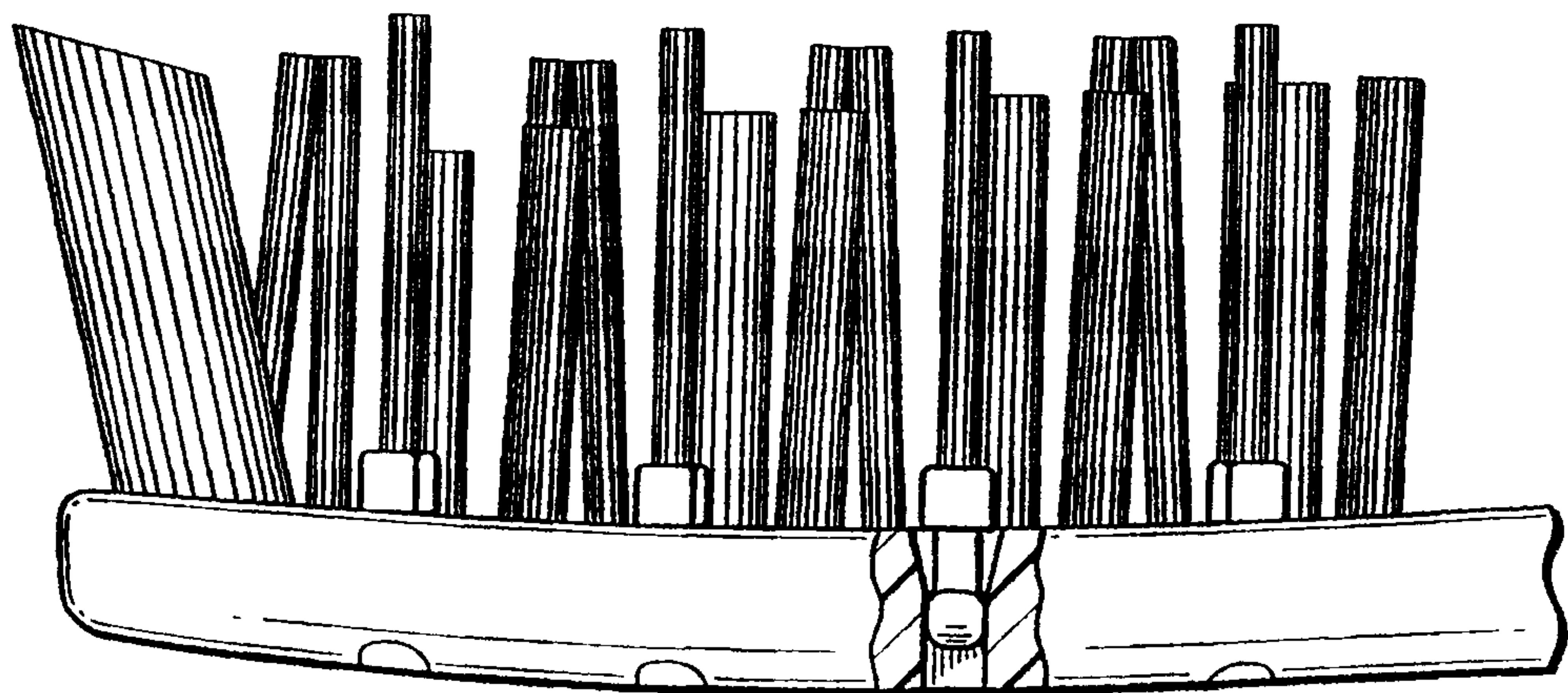
**FIG. 12**



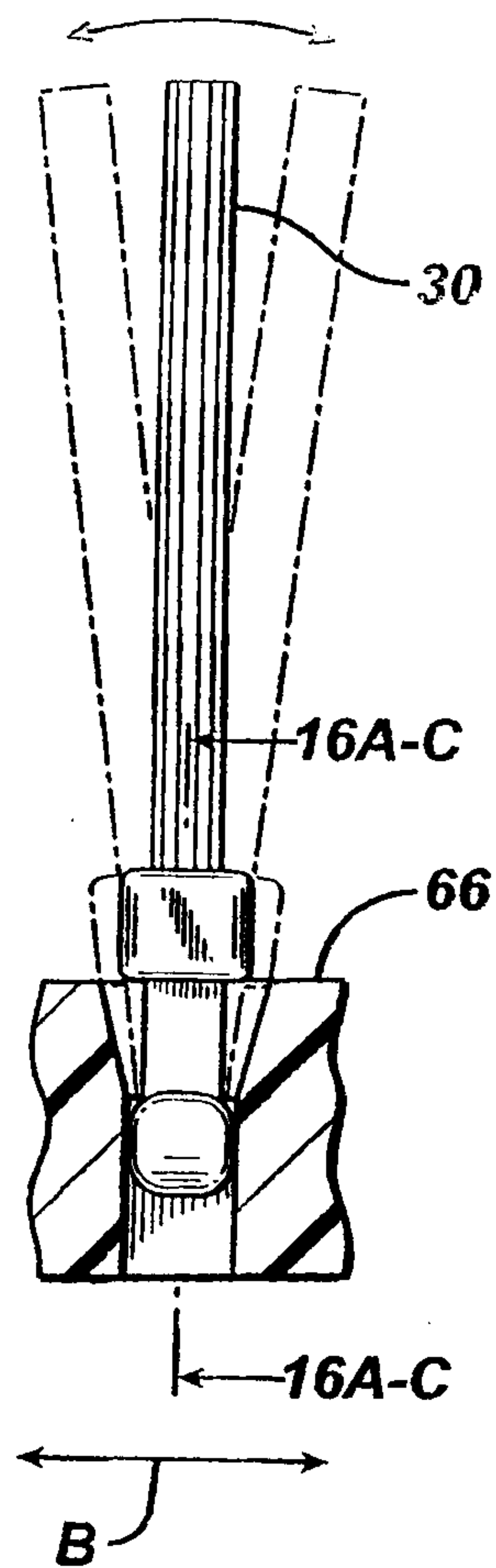
**FIG. 13**

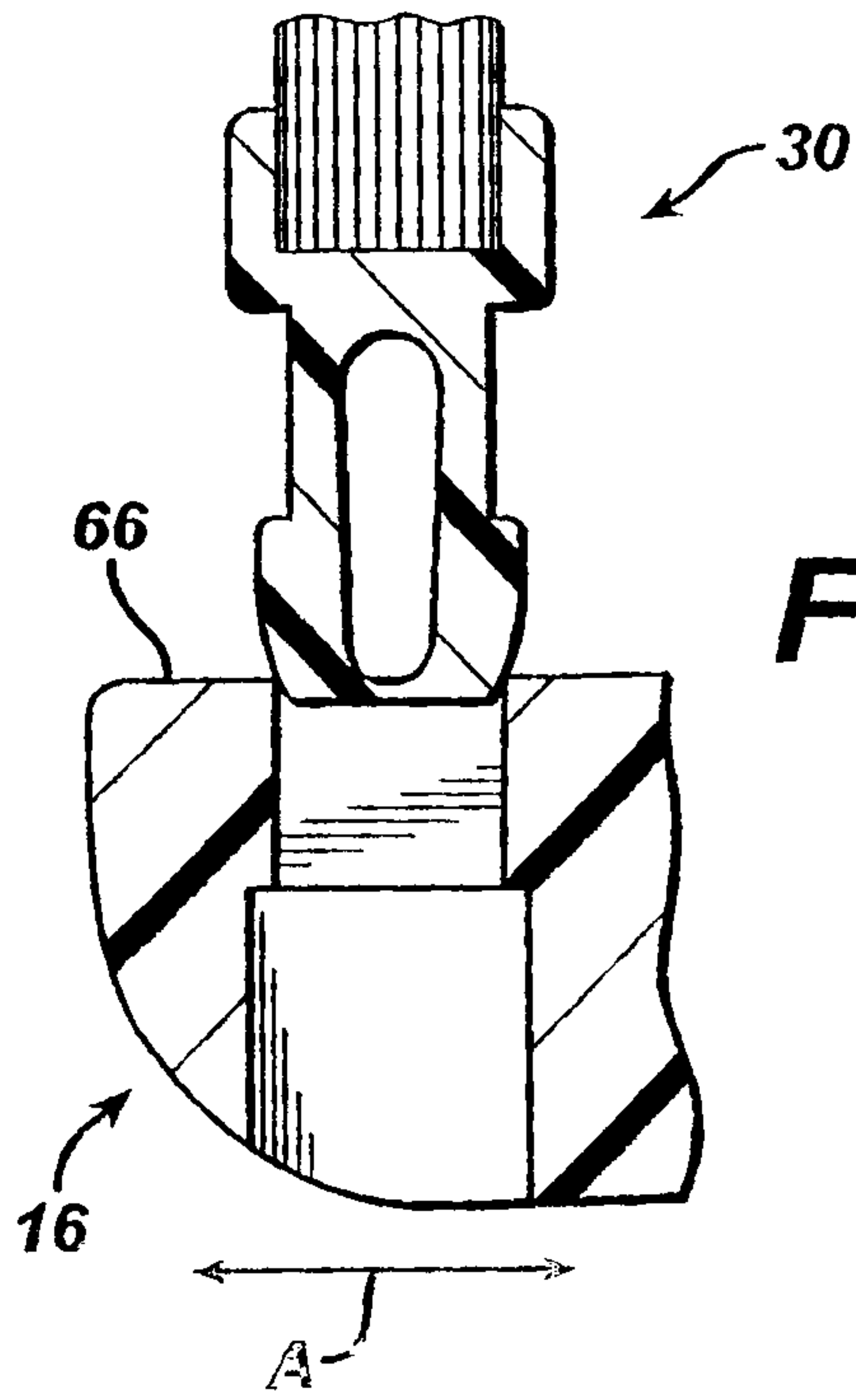


**FIG. 14**

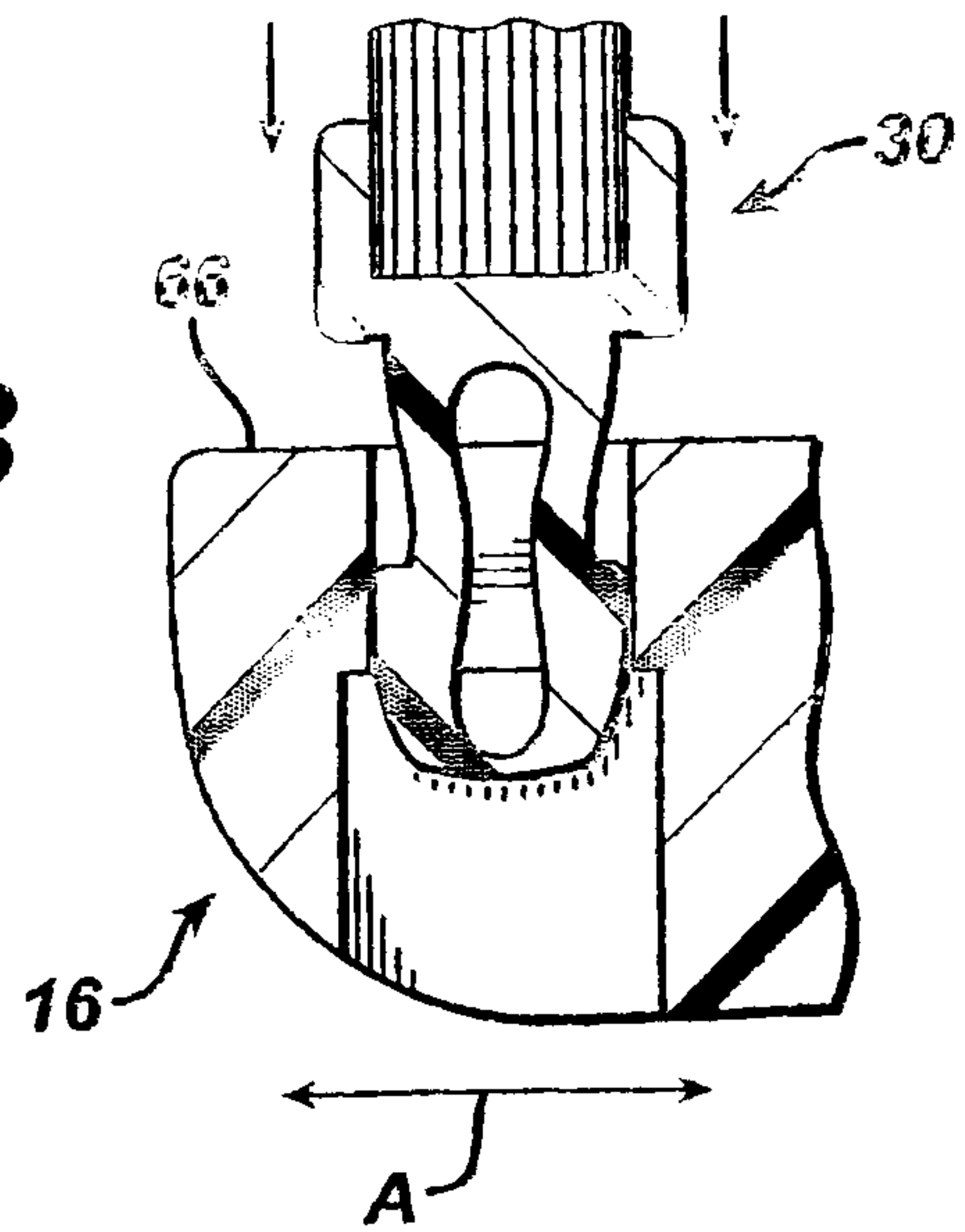


**FIG. 15**

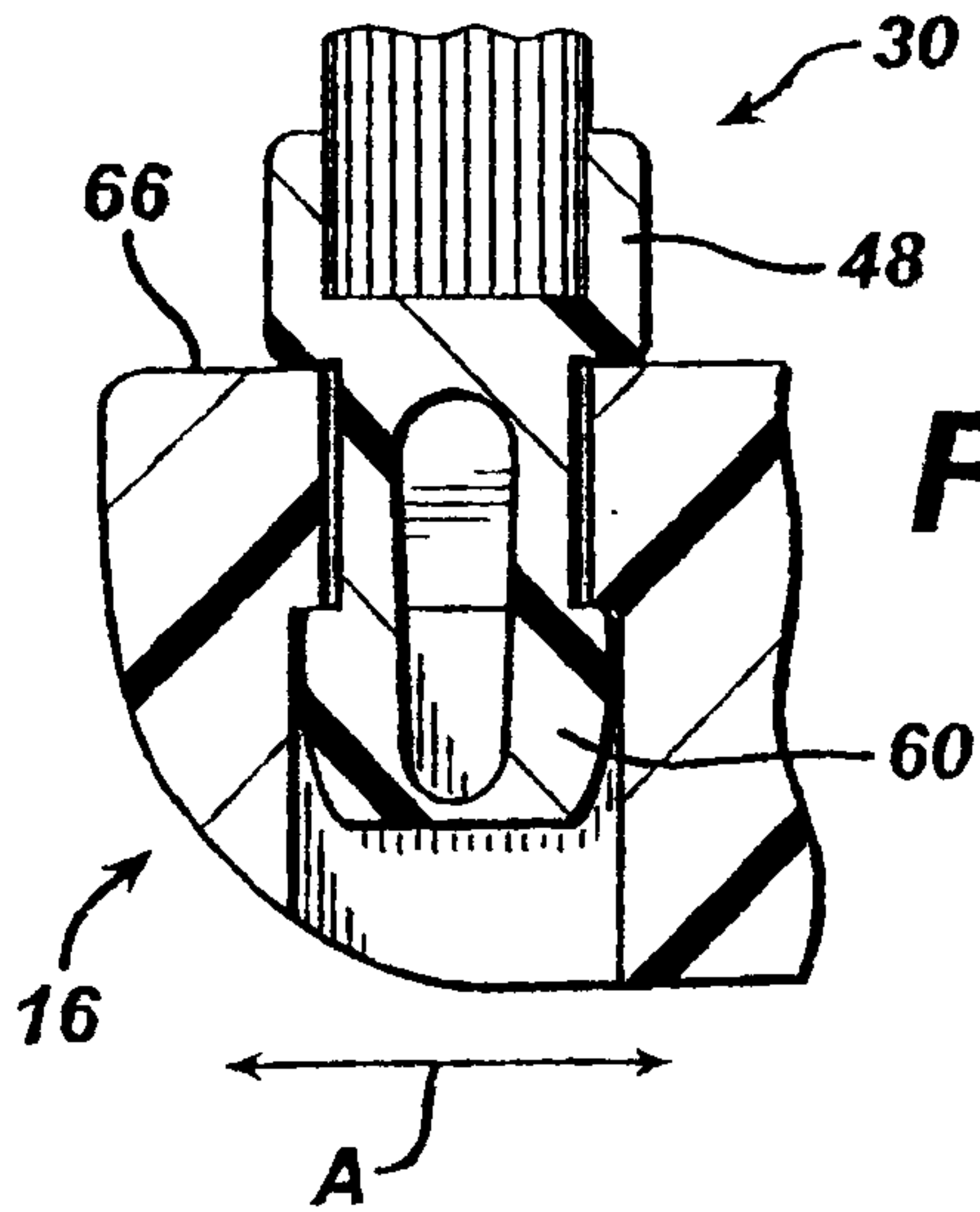




**FIG. 16A**

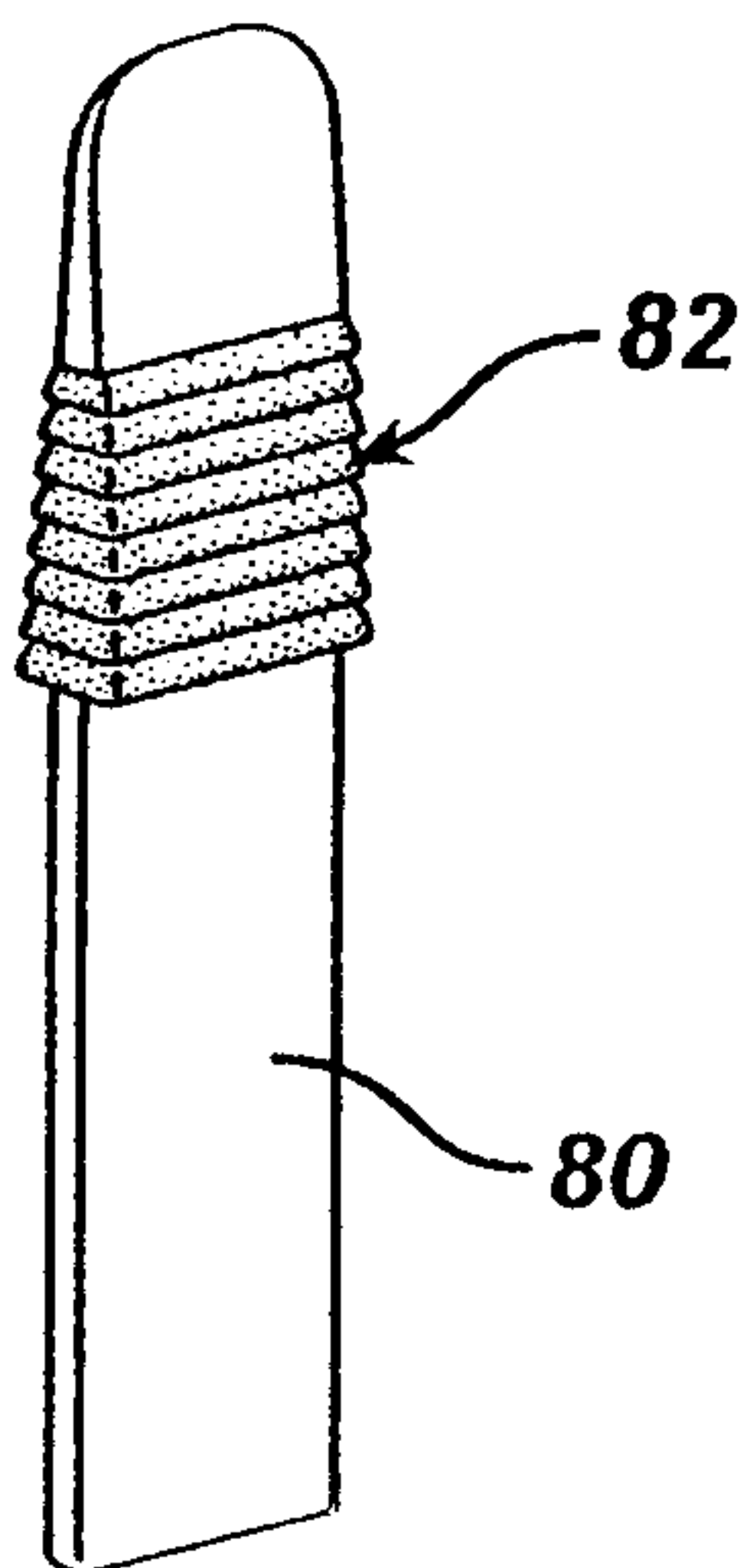


**FIG. 16B**



**FIG. 16C**

**FIG. 17**



**FIG. 18**

