

March 7, 1950

F. W. LAVERTY ET AL

2,500,129

LIQUEFACTION SYSTEM

Filed Aug. 29, 1944

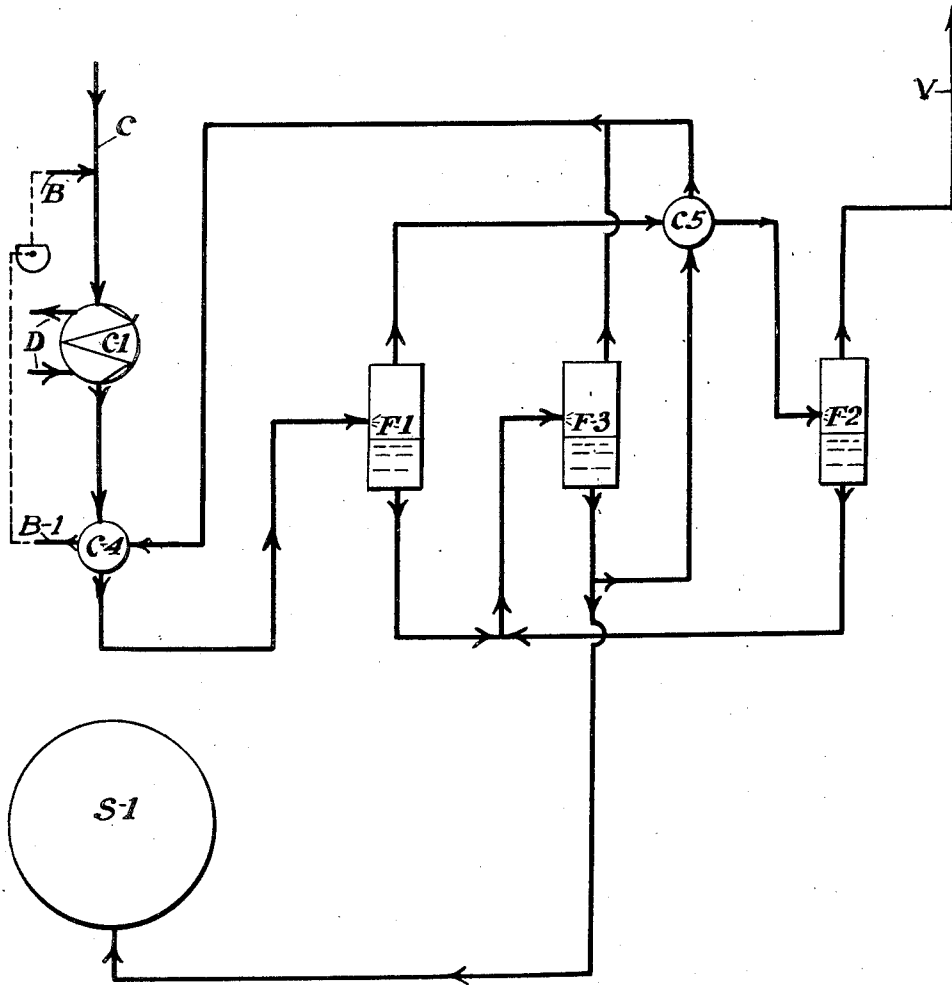

INVENTORS.
FRANCIS W. LAVERTY,
& ALLAN B. COLE.
BY
Fay, Gohrick, Chilton & Isler.
Attorneys.

UNITED STATES PATENT OFFICE

2,500,129

LIQUEFACTION SYSTEM

Francis W. Lavery and Allan B. Cole, Olean,
N. Y., assignors to Clark Bros. Co., Inc., Olean,
N. Y., a corporation of New York

Application August 29, 1944, Serial No. 551,758

4 Claims. (Cl. 62—175.5)

1

This invention relates to the liquefaction of natural gases, as for storage or transportation purposes. The natural gases contemplated comprise a mixture of which the principal constituent is methane. Other constituents are or may be nitrogen, hydrogen, helium, argon, oxygen or other gases or vapors having lower boiling point than that of methane.

For the purposes of this invention it is desired to liquefy principally the methane of the natural gas feed stream and to rid the product of the more volatile constituents. It is not the purpose to obtain a pure methane product, but rather to eliminate the nitrogen or other relatively volatile constituents at a rate equal to or greater than that at which such volatile constituents enter the system with the fresh stream, so as to prevent such constituents from building up in the system. As will be appreciated by one familiar with the art, nitrogen is the most important of those constituents more volatile than methane, because nitrogen occurs more frequently and in greater amount in natural gases, and is useless in the combustion ultimately contemplated for the methane. For simplification the term "volatile constituent" will be sometimes hereinafter employed to embrace principally nitrogen but also other such constituents as above noted which boil below the boiling point of methane.

In the present processes employed in liquefaction of natural gases containing either traces or reasonably small amounts of volatile constituents, it is customary at various points in the cycle to vent, and if the constituent concentration is low, then only small amounts of methane are lost during this elimination step. However, with certain gases containing amounts of such constituents running relatively high, it is quite expensive to use such process, as entirely too much methane is lost during the venting. This invention has for its principal general object, to provide an economical and effective process for liquefaction of gases of which the principal constituent is methane, but which also contain more volatile constituents, in which process such constituents, and particularly nitrogen, is vented so that the liquefaction process as a whole is more efficient than heretofore.

Briefly, according to the invention the feed stream is liquefied, then it is vaporized by lowering the pressure, part of the flashed vapors are reliquefied, and that part of the stream which does not reliquefy is vented. The vented vapors are therefore much less rich in the methane, retention of which is desired, than would other-

2

wise be the case; so that the methane may be recycled for recovery of refrigeration therefrom, without the impairment to the system which would otherwise be the case.

To the accomplishment of the foregoing and related ends, said invention, then, consists of the steps hereinafter fully described and particularly pointed out in the claims; the annexed drawing and the following description setting forth in detail one approved method of carrying out the invention, such disclosed method, however, constituting but one of the various ways in which the principle of the invention may be used.

In the annexed drawing, the single figure there appearing is a diagrammatic lay-out of the units comprising that portion of the entire liquefaction apparatus and process which contain the venting or purging apparatus for the volatile constituents.

The present invention is intended primarily but not exclusively for use in what is generally called a cascade system which employs, for example, ethylene as refrigerant for liquefaction of the methane and associated more volatile gases.

In typical processes and apparatus now in use for the liquefaction of natural gas, of which the principal constituent is methane, the nitrogen is vented from the liquefied methane while the mixture is at a pressure of about 600 pounds and under such conditions for every part of nitrogen vented there would be approximately 10 parts of methane vented. This is, of course, not a serious loss of methane so long as the percentage of nitrogen in the methane is quite low, but would become a serious source of loss if the nitrogen content were very materially higher. In the event that the nitrogen content increases to substantially more than a trace, the methane loss would be considerable. It will be understood, of course, that in a cascade system any nitrogen not vented in the liquefaction stage will be carried in the recycle stream and in time, by reason of the additions of nitrogen from the feed gas, will build up to such a point that the entire system will be progressively less efficient and eventually even inoperative.

In the attached drawing there is shown only pertinent portions of the entire system, since the cascade method of liquefaction of gases is well known. The natural gas, preferably after water and carbon dioxide removal therefrom, is introduced through the line C at high pressure into an exchanger C—1 served by a refrigerant such as ethylene, and there liquefied, then, as indicated in the drawing by horizontal arrows D directed to and from the exchanger C—1, introduced into

3

the super-cooler C—4. At this second point as will appear refrigeration is recovered from the gas remaining after removal of volatile constituents therefrom, which remainder gas leaves the super-cooler C—4 through the line B—1, and eventually joins the main gas feed stream C, through line B as conventionally indicated in the drawing by the broken line including compressor E.

From the super-cooler C—4 the liquefied natural gas is carried to a flash chamber F—1 in which the first stage of the separation of the more volatile constituents from the methane takes place. In the flash chamber, the liquefied natural gas is "flashed," which causes lowering the temperature of the liquid methane by evaporating some of the liquid of the mixture, through the expedient of rapidly lowering the pressure imposed thereon to approximately 120 lbs. per square inch. There will accordingly be a considerable enrichment of the more volatile constituents in the vapor state. The liquid from the flash drum F—1, is then further flashed to 25 lbs. per sq. in. in the flash drum F—3 and the resulting liquid methane drawn off from drum F—3 is then ready for storage, as in container S—1.

The vapors resulting from the flashing of the material in the flash chamber F—1 are partially reliquefied in the exchanger C—5 by some of the liquid methane from the flash chamber F—3, and the mixture, after leaving heat exchanger C—5, is then introduced into the flash drum F—2. There is a further enrichment of volatile constituents in the vapor in the drum F—2, and this vapor is then purged from the F—2 drum by way of the vent V. As will be appreciated, the vent V is of restricted character so as to maintain sufficient pressure within the chamber of the flash drum F—2 to transfer the liquid product thereto to the flash drum F—3. For example the parts may be so proportioned as to maintain pressures of 115 pounds in the flash drum F—2, 25 pounds in the flash drum F—3, and 15 pounds at the mouth of the vent V.

By thus flashing in successive steps the mixture of methane and more volatile constituents, and by partially reliquefying the vapor from the first flash drum, it is possible to draw off a higher concentration of constituents than has been heretofore possible, and to thus avoid wasting methane in the purged gas. Furthermore, the system will tend to be self-balancing regardless of the amount of volatile constituents present in the feed stream; the greater such amount, the greater will be the amount of constituents vaporized in the flash drums and purged.

The flashed vapors are recycled by introduction into the feed stream C, at B, and preferably recovery of refrigeration available in the flashed vapors is had before such recycling. Thus, a first stage of such recovery is had in the super-cooler C—4, from which the vapors emerge by way of the line B—1, and may have further heat exchange in other elements not illustrated before entering the main feed stream C for reliquefaction therewith; further recovery and recycling details forming no part of the present invention.

The methane vaporized in the heat exchanger C—5, together with the vapors from the flash drum F—3 are employed in the recycling system wherein recovery of their refrigeration is had. It is not thought necessary to describe the recycling system in detail, as recycling is well known in the art, it is here indicated by the heat exchanger C—4 arranged as a methane super-cooler.

4

It being understood that other heat exchangers may be employed in sequence for recovering further refrigeration from the recycle stream. Ultimately, the stream is compressed and has re-entry for reliquefaction with the feed stream as at the arrow B. Methane revaporized by heat losses in the container S—1 may also be recycled, compressed, and reintroduced into the system at B for reliquefaction.

As will be appreciated by one familiar with the art, the flash drums F—1 and F—2 could, if desired, be replaced by a fractionating tower which will purge a stream rich in volatile constituent gases, without in other ways affecting the principles herein described.

It will, of course, be understood that, depending upon the volatile content of the feed gas, it may be desirable to vary the pressure and consequently the temperatures in order to keep the amount of volatile which is recycled down to a desired minimum.

The present method of removal or purging of volatile gas can be used in any system of liquefaction of natural gas, i. e., in either the cascade system, the Linde system, or an expander type of liquefaction.

Other modes of applying the principle of our invention may be employed instead of the one explained, change being made as regards the method herein disclosed, provided the step or steps stated by any of the following claims or the equivalent of such stated step or steps be employed.

We, therefore, particularly point out and distinctly claim as our invention:

1. In the treatment of natural gases containing methane and a more volatile constituent, liquefying a stream of gas flashing the liquefied gas to produce a vapor relatively rich in said constituent and a liquid relatively high in methane content, partially re-liquefying said vapor, flashing said re-liquefied vapor to produce a second vapor relatively richer in said constituent and a liquid relatively high in methane content, and venting said second named vapor, combining said liquids relatively high in methane content, flashing said combined liquids to produce a third liquid higher in methane content and a third vapor and employing some of said third liquid in said partial liquefaction.

2. In the treatment of natural gases containing methane and a more volatile constituent, liquefying a stream of gas, flashing the liquefied gas to produce a vapor relatively rich in said constituent and a liquid relatively high in methane content, partially re-liquefying said vapor, flashing said re-liquefied vapor to produce a second vapor relatively richer in said constituent and a liquid relatively high in methane content, and venting said second named vapor, combining said liquids relatively high in methane content, flashing said combined liquids to produce a third liquid higher in methane content and a third vapor.

3. In combination with the liquefaction of a stream of natural gas containing methane and a more volatile constituent: separation of the liquefied gas into a liquid relatively high in methane content, a vapor relatively high in methane content, and a vapor relatively high in said constituent, combining said first named vapor with said stream for liquefaction therewith, and venting said second named vapor.

4. In combination with the liquefaction of a stream of natural gas containing methane and a more volatile constituent: separation of the lique-

5

fed gas into a liquid relatively high in methane content, a vapor relatively high in methane content, and a vapor relatively high in said constituent, cooling of said stream by said first named vapor and combining the same with said stream for liquefaction therewith, and venting said second named vapor.

FRANCIS W. LAVERTY.
ALLAN B. COLE.

5

10

Number	Name	Date
2,122,238	Pollitser	June 28, 1938
2,142,446	Kopp	Jan. 3, 1939
2,175,590	Barton	Oct. 10, 1939
2,214,790	Greenewalt	Sept. 17, 1940
2,280,383	De Baufre	Apr. 21, 1942
2,315,424	Hill et al.	Mar. 30, 1943

6

REFERENCES CITED

The following references are of record in the file of this patent:

UNITED STATES PATENTS