

No. 626,887.

Patented June 13, 1899.

H. B. CAMP.
CLAY CUTTING MACHINE.

(Application filed Nov. 28, 1898.)

(No Model.)

3 Sheets—Sheet 1.

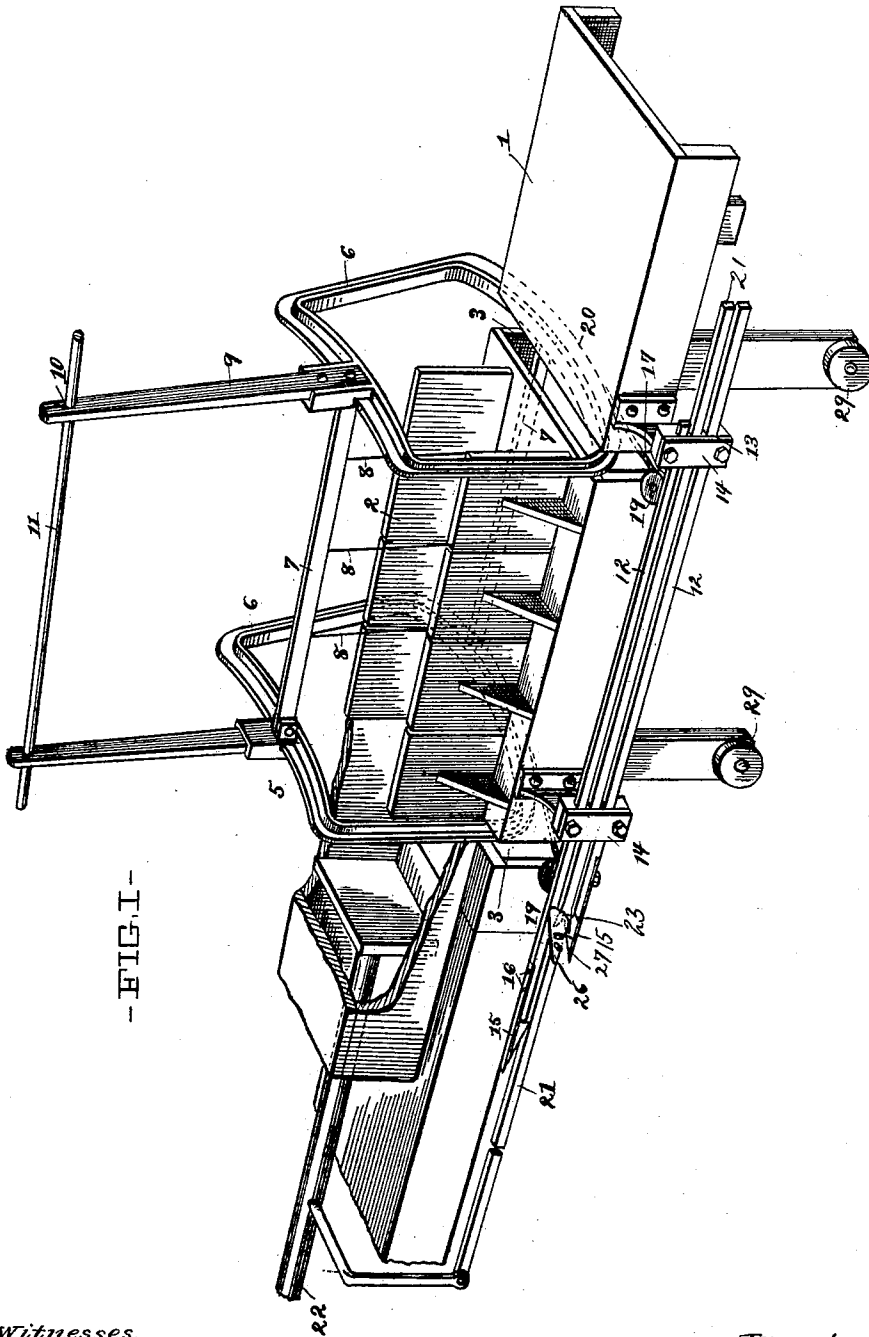

-FIG. 1-

Witnesses,
J. M. Wilkins
J. C. Turner

Inventor,
Henry B. Camp
By
Amos Austin
Atty.

No. 626,887.

Patented June 13, 1899.

H. B. CAMP.
CLAY CUTTING MACHINE.

(Application filed Nov. 28, 1898.)

(No Model.)

3 Sheets—Sheet 2.

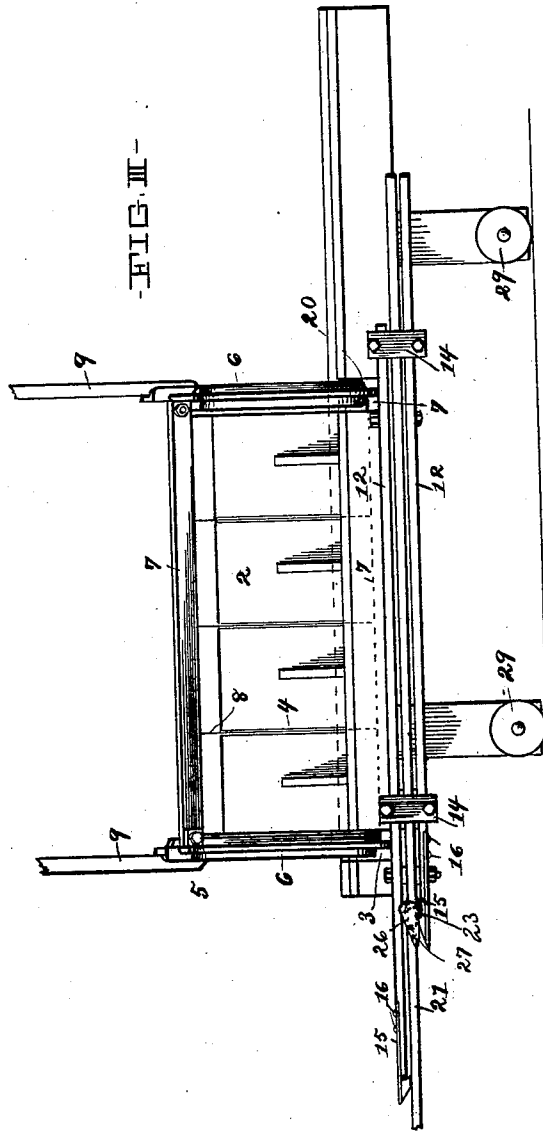
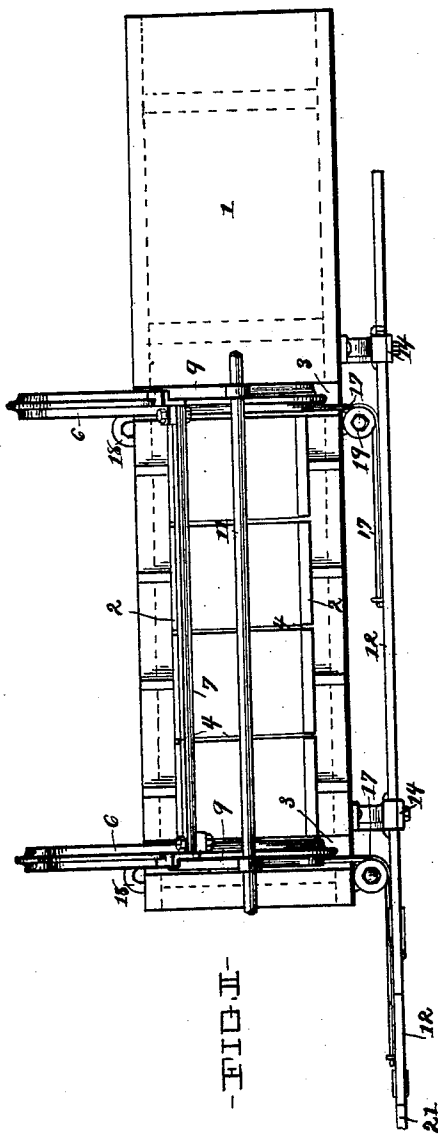

Witnesses,
G. M. Wilkins
J. C. Turner

Inventor,
Horner B. Camp
By
A. A. Austin
Atty.

No. 626,887.

Patented June 13, 1899.

H. B. CAMP.
CLAY CUTTING MACHINE.

(Application filed Nov. 28, 1898.)

(No Model.)

3 Sheets—Sheet 3.

-FIG. V-

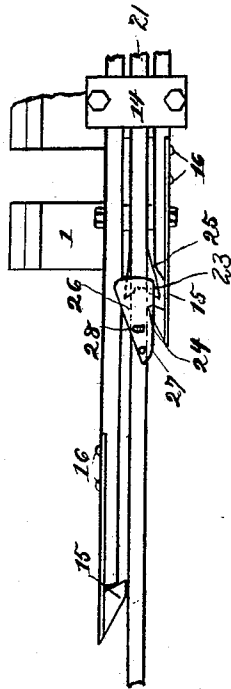
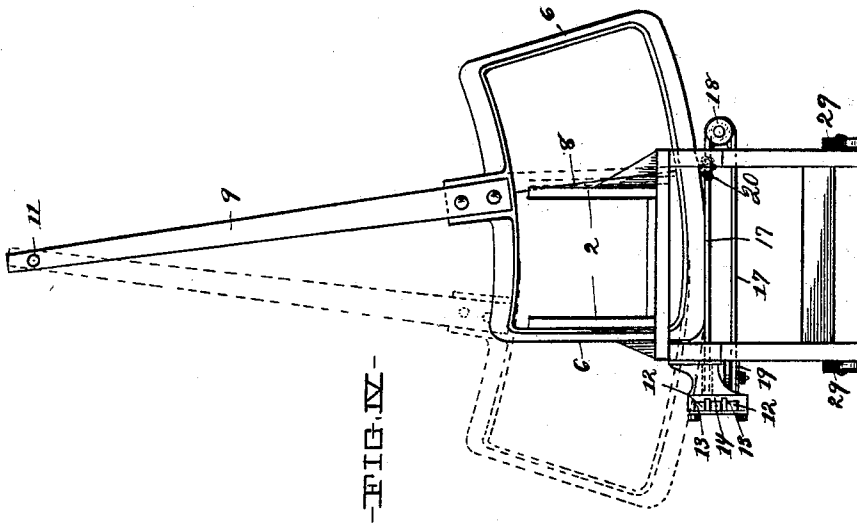
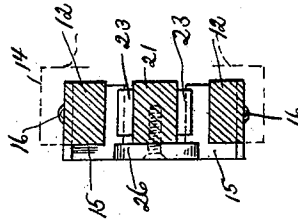

FIG. VI.



-FIG. IV-

Witnesses,

G. M. Wilkins
J. C. Turner

Inventor

Horace B. Camp

By

A. M. Austin

Atty.

UNITED STATES PATENT OFFICE.

HORACE B. CAMP, OF AKRON, OHIO.

CLAY-CUTTING MACHINE.

SPECIFICATION forming part of Letters Patent No. 626,887, dated June 13, 1899.

Application filed November 23, 1898. Serial No. 697,597. (No model.)

To all whom it may concern:

Be it known that I, HORACE B. CAMP, a citizen of the United States of America, residing at Akron, Summit county, Ohio, have invented certain new and useful Improvements in Clay-Cutting Machines, of which the following is a specification in such full, clear, and exact terms as to enable any person skilled in the art to which it appertains to make, construct, and use the same.

The annexed drawings and the following description set forth in detail one mechanical form embodying the invention, such detailed construction being but one of various mechanical forms in which the principle of the invention may be used.

In said annexed drawings, Figure I represents a view in perspective of my improved clay-cutting machine; Fig. II, a plan view showing the cutter swung to one side; Fig. III, a side elevation of my device; Fig. IV, an end view, partly in section; Fig. V, a detailed view showing the trip mechanism, and Fig. VI is a transverse vertical section of Fig. V.

My improved clay-cutting machine is designed especially for use in connection with a clay-machine having a plunger that forces a bar of clay onto a cutting-table. The table 1 is provided with a trough or box 2, that receives the clay as it comes from the clay-machine ready to be cut into sections of suitable length. At each end of the trough a groove or opening 3 is formed crosswise of the table, and at suitable intervals slits 4 are also provided through the trough and the top of the table.

The cutter 5 consists of the frames 6, secured together by the connecting-rods 7, arranged one above and the other below the top of the table. Wires 8 are strung between said rods at proper distances to permit same to pass through slits 4. The frames are preferably suspended by means of arms 9, provided with eyes 10, from a wire or rod 11, arranged above the center of the table, and oscillate in the grooves provided at the ends of the trough. Said frame may be otherwise arranged, provided a reciprocating movement is permitted.

Actuating-rods 12 are arranged at the side of the table, one above the other and a suit-

able distance apart, and slide in grooves 13, formed in the brackets 14. The front ends of the rods are provided with catch-springs 15, secured thereto by means of rivets or bolts 16. Ropes or chains 17 are looped to run over idlers 18, provided on the opposite side of the table, and their ends pass over rollers 19 and are secured to the upper and lower rods, respectively. Said ropes or chains are securely attached, as at 20, to the cutter-frames.

A reciprocating bar 21, that is secured to the plunger 22 of a clay-machine, has a bearing in the brackets between the actuating-rods. Said bar is provided with vertically and forwardly projecting flanges or wings 23, that are recessed on their inner edges 24 and have their outer edges 25 correspondingly inclined or beveled. A trip-block 26, oval or V-shaped in outline, is pivoted at its smaller end to the bar, so that its free end will overlap one of the wings. The width of said free end is slightly greater than the width of the wings. Said block is permitted a limited movement on its pivot by any suitable means, such as pin 27 and slot 28.

When the plunger begins its return stroke after forcing a bar of clay onto the cutting-table, one of the wings on the reciprocating bar engages the nearest catch-spring. If this happens to be the one secured to the lower actuating-rod, as shown in the drawings, the spring lifts the trip-block and the lower wing and catch engage. The rod is pulled forward with the return stroke of the plunger, and in turn the rod actuates the cutter, which swings in the groove provided in the top of the table and severs the bar of clay into sections. As the lower actuating-rod moves forward the upper actuating-rod is pulled backward by the chains secured to the cutter. The trip-block, however, has been lifted by the lower catch-spring, so that its upper edge is above the top of the upper wing and the upper catch-spring rides over said trip-block and past the wing without coming into engagement therewith. The tension of the upper spring is not sufficient to disengage the lower catch and wing, as they are held together securely by the resistance offered to the cutting-wires by the clay. When the plunger has reached the end of its return stroke and begins to force a

fresh bar of clay onto the cutting-table, the lower wing and catch automatically disengage and the upper catch rides over the beveled edge of the upper wing, permitting the same to pass. The fresh bar pushes the severed clay-sections from the table, and when the plunger begins its return stroke the upper catch engages with the upper wing and the bar of clay is severed by the return swing of the cutter.

The cutting-table is preferably mounted upon wheels or rollers 29, so that it can be adjusted to the clay-machine or pushed aside when not in use. The cutting-frames are movably secured in place, so that they can be moved with and adjusted to the table. By this construction the cutting-frame is actuated directly from the plunger of the clay-machine and I am enabled to utilize positively the power necessary to cause the return stroke of the plunger. Separate gearing for the cutting mechanism is therefore unnecessary and a corresponding saving in cost is effected. Automatic engagement between the reciprocating bar and actuating-rods is obtained by means of the catch-spring and the trip device, and as the cutter is actuated only by the return stroke of the plunger a bar of clay is severed at each oscillation. The position and operation of the cutter also permit the wires to enter and leave the clay at an angle, whereby a cleaner and smoother cut is obtained than is otherwise possible.

What I claim is—

1. In a clay-machine, the combination with an expressing-machine having a plunger, and a cutting-table, of a cutter movable transversely of the table, and means for actuating said cutter by the reciprocating plunger of the clay-machine, substantially as described.

2. In a clay-machine, the combination with an expressing-machine having a plunger, and a cutting-table, of a cutter oscillating in grooves provided in the top of said table and actuated by the return stroke of the plunger of said clay-machine, substantially as described.

3. In a clay-cutting machine, the combination with a cutting-table and a cutter movable transversely of said table, of movable actuating-rods secured to the cutter by suitable means, and provided with catches, a reciprocating bar arranged between said actuating-rods and provided with projecting wings to engage said catches, and means for actuating said plunger-bar, substantially as described.

4. The combination with a cutting-table having grooves and slits in its top, brackets secured to said table, and a cutter pivoted to oscillate in said grooves and slits, of actuating-rods movable in said brackets and secured

to the cutter and to each other by suitable means, said actuating-rods having catch-springs on their ends, a reciprocating bar arranged between said actuating-rods and provided with projecting wings to engage said catch-springs, and means for actuating the reciprocating bar, substantially as described.

5. In a clay-machine, the combination with an expressing-machine having a plunger, a cutting-table provided with movable actuating-rods, catch-springs on said rods, and a movable cutter secured to each of said actuating-rods by suitable means, of a reciprocating bar arranged between said actuating-rods and provided with projecting wings adapted to engage with said catch-springs, a trip-block pivoted to the reciprocating bar and preventing engagement between said wings and catch-springs on the forward stroke of the reciprocating bar, said reciprocating bar being actuated directly by the plunger of the clay-machine, substantially as described.

6. In a clay-machine, the combination with an expressing-machine having a plunger and a cutting-table adjustable thereto, and provided with grooves and slits through its top, of a cutter consisting of frames secured together by connecting-rods and having cutting-wires strung between said rods, said cutter being pivoted to oscillate in the arc of a circle in said grooves and slits, and means for automatically actuating said cutter by the return stroke of the plunger of said clay-machine, substantially as described.

7. In a clay-machine, the combination with an expressing-machine having a plunger, a cutting-table having grooves and slits in its top, and provided with bearings on its side, a cutter oscillating transversely of said table in the grooves and slits, and actuating-rods, having catch-springs at one end, secured by suitable means to said cutter and to each other and reciprocating in the bearings provided by said table, of a reciprocating bar suitably secured to the plunger of the clay-machine and provided with wings having recessed inner edges and oppositely-beveled outer edges, and a trip-block pivoted to said reciprocating bar and permitted a limited swinging movement thereon, said trip-block having oppositely-inclined sides and a free end, said reciprocating bar being actuated directly by the plunger of said clay-machine, substantially as described.

In witness whereof I sign this application, in the presence of two witnesses, this 21st day of November, 1898.

HORACE B. CAMP.

Witnesses:

G. H. FOSTER,
G. M. WILKINS.