



(51) International Patent Classification:

G07F 17/32 (2006.01) G07F 11/24 (2006.01)  
G07F 11/44 (2006.01) B65D 83/04 (2006.01)  
G07F 11/42 (2006.01)

(21) International Application Number:

PCT/IB2021/000820

(22) International Filing Date:

29 November 2021 (29.11.2021)

(25) Filing Language:

English

(26) Publication Language:

English

(30) Priority Data:

63/120,239 02 December 2020 (02.12.2020) US  
63/242,299 09 September 2021 (09.09.2021) US

(71) Applicant: **OUTFORM LTD.** [IL/IL]; 5 David Navon St.,  
569100 Moshav Magshimim (IL).

(72) Inventor: **HAROUSH, Ariel**; 1912 North East 119 Road,  
North Miami, FL 33181 (US).

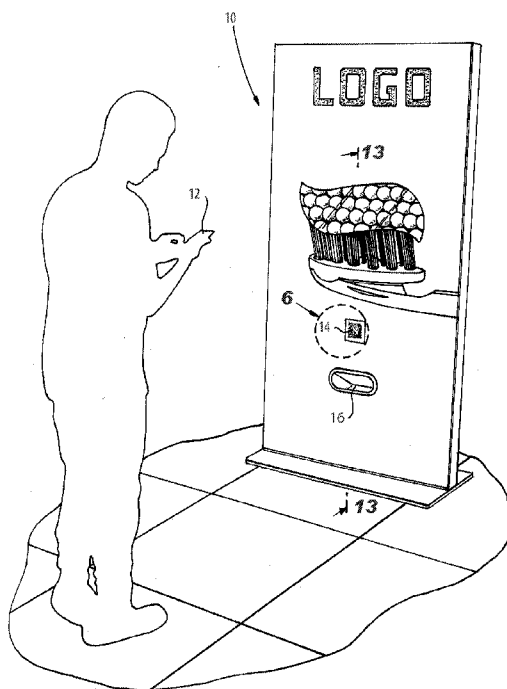
(74) Agent: **PUGATSCH, Ena**; Reinhold Cohn And Partners,  
P.O. Box 13239, 6113102 Tel Aviv (IL).

(81) Designated States (unless otherwise indicated, for every kind of national protection available): AE, AG, AL, AM, AO, AT, AU, AZ, BA, BB, BG, BH, BN, BR, BW, BY, BZ, CA, CH, CL, CN, CO, CR, CU, CZ, DE, DJ, DK, DM, DO, DZ, EC, EE, EG, ES, FI, GB, GD, GE, GH, GM, GT, HN, HR, HU, ID, IL, IN, IR, IS, IT, JO, JP, KE, KG, KH, KN, KP, KR, KW, KZ, LA, LC, LK, LR, LS, LU, LY, MA, MD, ME, MG, MK, MN, MW, MX, MY, MZ, NA, NG, NI, NO, NZ, OM, PA, PE, PG, PH, PL, PT, QA, RO, RS, RU, RW, SA, SC, SD, SE, SG, SK, SL, ST, SV, SY, TH, TJ, TM, TN, TR, TT, TZ, UA, UG, US, UZ, VC, VN, WS, ZA, ZM, ZW.

(84) Designated States (unless otherwise indicated, for every kind of regional protection available): ARIPO (BW, GH,

(54) Title: TOUCHLESS SYSTEM FOR DISPENSING PRODUCT SAMPLES

Fig. 1



(57) Abstract: A system is disclosed for dispensing a product sample to a consumer that includes a storage compartment for holding a plurality of spherical pods each containing a product sample in a closely-packed assemblage, a dispensing area communicating with the storage compartment and including an access port accessible by a consumer to obtain a single spherical pod, a dispensing wheel mounted for rotation adjacent the dispensing area for transferring a single spherical pod from the storage compartment to the access port, and an agitator wheel mounted for movement within the storage compartment to agitate the spherical pods within the storage compartment so as to reduce friction between adjacent spherical pods in the closely -packed assemblage and promote movement of pods from the storage compartment towards the dispensing wheel.



GM, KE, LR, LS, MW, MZ, NA, RW, SD, SL, ST, SZ, TZ, UG, ZM, ZW), Eurasian (AM, AZ, BY, KG, KZ, RU, TJ, TM), European (AL, AT, BE, BG, CH, CY, CZ, DE, DK, EE, ES, FI, FR, GB, GR, HR, HU, IE, IS, IT, LT, LU, LV, MC, MK, MT, NL, NO, PL, PT, RO, RS, SE, SI, SK, SM, TR), OAPI (BF, BJ, CF, CG, CI, CM, GA, GN, GQ, GW, KM, ML, MR, NE, SN, TD, TG).

**Published:**

- *with international search report (Art. 21(3))*
- *before the expiration of the time limit for amending the claims and to be republished in the event of receipt of amendments (Rule 48.2(h))*

**TOUCHLESS SYSTEM FOR DISPENSING PRODUCT SAMPLES****CROSS-REFERENCE TO RELATED APPLICATION**

The subject application claims the benefit of priority to U.S. Provisional Patent  
5 Application Serial No. 63/242,299, which was filed on September 9, 2021, and U.S.  
Provisional Patent Application Serial No. 63/120,239, which was filed on December 2,  
2020, the contents of which are incorporated by reference herein in their entireties.

**BACKGROUND OF THE INVENTION**10 **1. Field of the Invention**

The subject invention is directed to a dispensing machine, and more  
particularly, to a system and method for dispensing product samples to a consumer  
without requiring physical contact of the dispensing machine and the consumer.

15 **2. Description of Related Art**

Mechanical coin-operated dispensing machines have been around for many  
20 years. A coin is inserted in a slot, the coin is verified to determine size and weight and  
then an item from the machine is released or the coin is added to a total, which, when  
reached releases the goods. A problem with such machines is that only a certain class  
of low-priced goods can be sold through such machines, since the use of coins limits  
the amounts that can reasonably be charged.

The problem may be solved by allowing paper money. However, paper money  
requires elaborate electronic recognition systems, which can easily fail when banknotes  
are dirty or creased. A further solution is to allow credit cards, but not all people have  
credit cards. People under the age of 18 for example could not use such machines.

25 Another problem with coin-operated machines is that coin blanks, which are the  
same size and weight as the coin but have not been minted as coins, work in the

machine. Furthermore, there have been cases where National Mints have used the same blanks to make coins of different denominations for different countries, with the result that the lower valued coin was used in place of the higher valued coin to successfully fool coin-operated machines.

5           A further problem with dispensing machines is that they are built specifically for the goods that they dispense. There is very little flexibility in the type of goods that can be included in the machine, and even a fairly small change of price may often require reprogramming at the machine. An additional problem, irrespective of the machine being for coins or credit cards or banknotes, is that the machine requires  
10           contacting specific surfaces by users, something which is a particular issue with COVID-19 and other diseases that may be passed on by touch.

          Marketers have also encountered problems during the distribution of samples, and sample giveaways that have yet to be solved. Sample distribution programs have to be staffed to prevent people from taking multiple items at once. The need to staff a  
15           kiosk also creates a limitation on hours and locations that the sample kiosk can operate.

          A further problem for marketers is allowing potential consumers to try their products so that they are more inclined to purchase them. The marketer wants to know the details of the potential purchaser. Potential purchasers on the other hand, while happy to try the goods, are reluctant to provide details and often provide false details.  
20           Furthermore, marketers and vendors have no way of knowing whether a person has already tried the goods so that samples can be concentrated on potential new customers.

          Thus a clear need exists for sample distribution kiosks and vending machines to have improved handling, interaction, flexibility, and vending capabilities. The subject invention provides a novel solution to all of these problems and concerns.

### **SUMMARY OF THE DISCLOSURE**

The subject invention is directed to a new and useful system for dispensing a product sample to a consumer in a touchless manner. The system includes a storage compartment for holding a plurality of product sample containing spherical pods in a  
5 closely-packed assemblage, a dispensing area communicating with the storage compartment and including an access port accessible by a consumer to obtain a single spherical pod, a dispensing wheel mounted for rotation partially within the storage compartment and partially within the dispensing area for transferring a single spherical pod from the storage compartment to the access port; an agitator mounted for  
10 movement within the storage compartment to agitate the spherical pods within the storage compartment so as to reduce friction between adjacent spherical pods in the closely-packed assemblage and promote movement of pods from the storage compartment towards the dispensing wheel.

The system can also include a ramped guide path providing communication  
15 between the storage compartment and the dispensing area, wherein the guide path is sloped towards the dispensing wheel. The dispensing wheel can be mounted for rotation about an axis extending perpendicular to the guide path. The dispensing wheel can be mounted for rotation in a clock-wise direction.

The dispensing wheel can have a generally circular configuration and include a  
20 plurality of circumferentially spaced apart pockets, each pocket being shaped for receiving a spherical pod delivered from the ramped guide path to the access port. The dispensing wheel can have a sensing means associated with the plurality of circumferentially spaced apart pockets for detecting reception of a spherical pod within said pocket. The dispensing wheel can include a plurality of indentations, wherein each  
25 indentation is shaped and sized to fit one spherical pod at a time.

The agitator can be mounted for rotation about an axis extending perpendicular to the guide path. The agitator can have a generally elliptical configuration. The agitator can be mounted for rotation in a clock-wise direction and a counter-clockwise direction.

5           The system can also include a first motor for rotating the dispensing wheel and a second motor for rotating the agitator. A motor controller can be used controlling the first and second motors. The system can also include a means for enabling a consumer to interact with the motor controller in a contact-less manner, using a mobile terminal image processor by way of an image, to enable a transfer of a spherical pod from the  
10 storage compartment to the access port in order to collect the spherical pod from the access port to receive a product sample.

A depth of the storage compartment can be less than twice a length of a diameter of the spherical pod. The storage compartment can include a vertically oriented divider partially bisecting the storage compartment.

15           A method of dispensing a product sample to a consumer is also disclosed. The method includes providing a plurality of spherical pods each containing a product sample in a closely-packed assemblage within a storage compartment of an enclosure, agitating the spherical pods within the storage compartment of the enclosure so as to reduce friction between adjacent spherical pods in the closely-packed assemblage and  
20 thereby promoting movement of the spherical pods from the storage compartment towards a dispensing area, rotating a dispensing wheel adjacent the dispensing area to transfer a single spherical pod from the storage compartment to the access port, dispensing a spherical pod to a consumer from an access port communicating with the dispensing area.

The method can include agitating the spherical pods in the storage compartment of the enclosure involves rotating an agitator mechanism within the storage compartment. Agitating can include rotating the agitator mechanism less than 360 degrees in a clockwise direction and rotating the agitator mechanism less than 360  
5 degrees in a counter-clockwise direction. The agitator rotation can be activated by a signal from a server external to the enclosure. A message can be sent from a user mobile terminal used for scanning a visual code on an outside of the enclosure to prompt the signal for activating rotation to be sent.

These and other features of the system and method of the subject invention will  
10 become more readily apparent to those having ordinary skill in the art to which the subject invention appertains from the detailed description of the preferred embodiments taken in conjunction with the following brief description of the drawings.

### **BRIEF DESCRIPTION OF THE DRAWINGS**

So that those skilled in the art will readily understand how to make and use the touchless sample dispensing system of the subject invention without undue experimentation, preferred embodiments thereof will be described in detail herein

5 below with reference to the figures wherein:

Fig. 1 is an illustration of the touchless sample dispensing system or machine of the subject invention in a typical commercial environment, wherein a consumer uses a mobile device to interact with the system in a touchless manner by way of an externally located image containing a code;

10 Fig. 2 is an illustration of the interior of the enclosure of the sample dispensing system shown in Fig. 1;

Fig. 3 is an enlarged localized view taken from Fig. 2, showing the manner in which maintenance personnel use a smart device to interact with the system in a touchless manner by way of an internally located image containing a code;

15 Figs. 4 and 5 illustrate interactive smart device screens for performing maintenance on the system;

Figs. 6 through 11 illustrate interactive smart device screens that enable a consumer to collect a product sample from the system in a touchless manner

20 Fig. 6 depicts a user scanning the external code with a camera of a mobile device;

Fig. 7 depicts a display of the mobile device after scanning the external code;

Fig. 8 depicts the display of the mobile device showing a self-identification process;

25 Fig. 9 depicts the display of the mobile device showing another self-identification process;

Fig. 10 depicts the display of the mobile device showing a second step in the self-identification process;

Fig. 11 depicts the display of the mobile device showing a promotion of the device;

5 Fig. 12 is a schematic diagram of the data flow interface for the system of the sample dispensing system of the subject invention;

Fig. 13 is an elevation view of the interior of the dispensing system shown in Fig. 1, illustrating the interior storage compartment holding a plurality of spherical pods each containing a product sample in a closely-packed assemblage and the  
10 dispensing area for transferring a single spherical pod from the storage compartment to the access port shown in Fig. 1;

Fig. 14 is an exploded perspective view of the interior of the dispensing system shown in Fig. 1, with parts separated for ease of illustration;

Figs. 15 through 17 illustrate the clockwise-rotational movement of the  
15 dispensing wheel as it transfers a single spherical pod from the storage compartment to the access port;

Figs. 18 through 27 illustrate the clockwise and counter-clockwise movements of the agitator wheel mounted within the storage compartment to agitate the spherical pods within the storage compartment;

20 Fig. 28 is a perspective view of a two-piece spherical pod, separated to show a product sample contained therein, wherein the pod is preferably made from a bio-degradable material; and

Fig. 29 is a perspective view of an alternate embodiment of the dispensing system of the subject invention, wherein products associated with the samples are  
25 displayed on shelves below the sample access port.

## **DETAILED DESCRIPTION OF THE PREFERRED EMBODIMENTS**

Referring now to the drawings wherein like reference numerals identify similar aspects of the subject invention, there is illustrated in Fig. 1 a contact-less system 10 for dispensing a product sample to a consumer or other user of the subject invention in a typical commercial environment, wherein a consumer uses a camera enabled smart device (e.g., a smart phone or similar portable electronic device) 12 to interact with the system 10 in a touchless manner by way of an externally located code 14, such as QR code or a SKU located on a front surface of the system 10 adjacent an access port 16, where the samples are retrieved.

Fig. 2 is an illustration of the interior of the sample dispensing system 10 shown in Fig. 1, with the localized view of Fig. 3 showing the manner in which maintenance personal use a mobile device 18 to interact with the system 10 in a touchless manner by way of an internally located QR code 20. The interior of the dispensing system 10 includes a storage compartment 22 for holding a plurality spherical pods (shown in detail in Fig. 28), each of which includes a product sample to be dispensed to a user or shopper a closely-packed assemblage. The dispensing system 10 also includes a dispensing area 24 communicating with the storage compartment 22 which includes an access port 16 accessible by a consumer to obtain a single spherical pod and a dispensing wheel 32 which rotates to trap and move single spherical pod at a time from the storage compartment 22 to the access port 16. An agitator wheel 34 (shown in Fig. 13) is also rotatably mounted for movement within the storage compartment to agitate the spherical pods within the storage compartment 22. As the pods are agitated static friction between certain adjacent spherical pods is eliminated and the pods are free to roll down the ramp 36 into one of the pockets of the dispensing wheel. Fig. 2 further shows a divider 13 that partially divides the storage compartment 22. The divider 13 is

vertical and only extends partially down the middle of the compartment providing structural support to the dispensing system, and connecting the front and back panels of the storage compartment.

Fig. 3 shows a user's mobile device 18 being used to scan the QR code 20 located on the front of the system 10. A successful scan and interaction with the system results in the dispensing wheel 32 turning and moving one pod, per scan, from the ramp 36 to the access port 16 for the user to retrieve.

Figs. 4 and 5 show the screens of interactive smart device screens that are being used to access and download information about status of the system and perform routine maintenance on the system. The status can include the fill level, the usage, the expectant life of the motors, and so on. Fig. 4 shows terminal 12 of a user being asked to share their location to ensure that the operator is actually on site and next to the kiosk being worked on. The terminal 12 screen shows an operator's name 41 or identifier at the top of the screen along with an "allow/don't allow" widgets 42/44 below asking for the precise location of the terminal 12 to be shared with a remote server. Fig. 5 shows a next step of a maintenance terminal 12, where the user inputs their personal identifier 51 and company identifier 52 are shown ready to be filled and a location has been shared in box 54.

Figs. 6 through 11 illustrate interactive smart device screens that enable a consumer to collect a product sample from the system 10 in a touchless manner using a mobile device or terminal 12, while Fig. 12 is a schematic diagram of the data flow interface for the system 10 of the subject invention. Fig. 6 shows the mobile device or terminal 12 being used to scan the code 14, located on the outside of the system 10. As the QR code is scanned, the mobile device's or terminal's 12 internal processors decode the embedded code of the QR code and direct the user to a website, app, or

other landing page that is hosted by an external server, where the user's contact information can be input. Fig. 8 depicts the display of the mobile device or terminal 12 showing a self-identification process, where the user is prompted to use a pre-existing account 80 or profile on a secondary network such as Facebook, Google, or an existing e-mail address. Fig. 9 depicts the display of the mobile device or terminal 12 showing another self-identification process, where the user is prompted to input the user's name and contact info into boxes 90, along with an age verification button 92. Once registration has been completed, a user can hit the submit button 94. Once the information has been input and transferred to the system 10 server, a verification code is sent back to the contact the user had provided in the previous step, as depicted in Fig. 10. The verification code is then input into box 100 on the screen of the terminal 12, and the collect sample button 102, can be pressed. The button 102 activates the dispensing wheel and moves one pod to the access port. Fig. 11 depicts a mobile device or terminal 12, after the sample had been delivered, showing a promotion and information 110 about the product sample. Preferably, the system 10 is configured to collect information from and deliver information to the consumer, and it requires verification to prevent a user from collecting more than one pod or sample. Moreover, the dispensing of product samples is controlled by reference to one or more databases stored on a remote server.

Fig. 12 depicts the data flow interface for the system of the sample dispensing system. After a user scans the QR code 14 and enters their contact details 120, that contact information is sent to a server 30 for validation. Once validated, server 30 sends a "dispense" command to a second server 31, but do not directly to the sample dispensing system 10. The system 10 listens for the "dispense" command 121 by monitoring the second server 31 server. This method helps ensure that a sample is

dispensed even if the IP address or location of the kiosk changes. The contact information can also be stored by the third party, preferably one that supplies the samples on a spreadsheet or database 35.

Referring now to Figs. 13 and 14 the interior defined within the enclosure of the dispensing system 10 shown in Fig. 1, and with parts separated in Fig. 14 for ease of illustration. The system 10 includes a dispensing wheel 32 mounted for rotation adjacent the access port 16 and an oval or otherwise elliptically shaped agitator wheel 34 mounted for movement within the storage compartment 22 to agitate the spherical pods 25 within the storage compartment 22 so as to reduce friction between adjacent spherical pods 25 in the closely-packed assemblage and promote movement of pods from the storage compartment 22 towards the dispensing wheel 32. The depth of the storage compartment 22 is less than twice a diameter of the spherical pod, ensuring that the pods are always in-line and ready to be received by the dispensing wheel 32. The sample dispensing system 10 further includes a first motor 42 for rotating the dispensing wheel 32 and a second motor 44 for rotating the agitator wheel 34. A ramped guide path 36 provides communication between the storage compartment 22 and the dispensing area 24, wherein the guide path 36 leads to the dispensing wheel 32. The dispensing wheel 32 is mounted for rotation in a clock-wise direction about an axis that extends perpendicular to the guide path 36. The dispensing wheel 32 has a generally circular configuration and includes a plurality of circumferentially spaced apart pockets 38, each for receiving a spherical pod 25 delivered from the ramped guide path 36. The dispensing wheel 32 has sensors 40 associated with each of the plurality of circumferentially spaced apart pockets 38 for detecting reception of a spherical pod 25.

The elliptical agitator wheel 34 is mounted for rotation in a clock-wise direction and in a counter-clockwise direction. The agitator wheel 34 is turned on when the dispensing wheel sensors 40 expect a spherical pod 25 but do not contact it, which means there is a blockage. The agitator wheel 34 can turn in a variety of ways including  
5 partially clock-wise and then counter-clockwise or make full rotations in one direction or the other, until the spherical pods 25 are freed and dispensing wheel sensors 40 feel a pod 25 within the pocket 38.

A first motor controller 46 is provided in the enclosure for controlling the first motor 42 and a second motor controller 48 is provided in the enclosure for controlling  
10 the second motor 44. In addition, communication means 50 are provided in the enclosure for enabling a consumer to interact with the motor controllers 46, 48 in a touch-less manner, using a smart device by way of a QR code, to obtain a spherical pod 25 from the access port 16 to receive a product sample. The communication means 50 allows the system 10 to communicate with remote servers to validate a potential  
15 customer or user account. The communication means 50 can include a router 146 and hardwire receivers 145.

The mechanics of the system 10 described above are concealed within a housing 140. The housing 140 houses and provides a mounting and support means 144  
for each of the motor controllers 46 and 48, the motors 42 and 44. The housing 140  
20 further houses the axle 147 on which the agitator wheel 34 and the axle 148 on which the dispensing wheel 32 spins on.

Referring to Figs. 15 through 17, in use clockwise-rotational movement of the dispensing wheel 32 causes the transfer of a single spherical pod 25 from the storage  
25 compartment 22 to the access port 16 of the dispensing area 24. As discussed

previously, the dispensing wheel 32 with pockets 38 sized to accommodate a single spherical pod 25, as pod 25 comes down ramp 36, the dispensing wheel 32 turns clockwise to transfer an individual pod 25 to the dispensing area 24.

Figs. 18 through 27 illustrate the clockwise and counter-clockwise movements of the agitator wheel 34, which is mounted partially within the storage compartment 22 and protrudes through ramp 36 to agitate the spherical pods 25 within the storage compartment 22. This reduces friction between adjacent spherical pods 25 in the closely-packed assemblage and promotes movement of pods 25 from the storage compartment 22 towards the dispensing wheel 32 by way of the ramped guide path 36.

10 The agitator wheel 34 will turn until a spherical pod 25 is positioned within the pocket 38. The agitator can rotate any number of times in one direction, and then change direction and rotates a number of times in the reverse direction. This back-and-forth rotation will continue until a pod 25 is detected by a sensor 40 in a pocket 38 of the dispensing wheel 32. The agitator wheel 34 is turned on when the dispensing wheel

15 sensors 40 expect a spherical pod 25 but do not contact it (as shown in Fig. 18-26, which means there is a blockage. Finally, in Fig. 27, a spherical pod 25 is freed and rolls down ramp 36 to pocket 38.

Fig. 28 is a perspective view of a two-piece spherical pod 25, separated into two hemi-spherical sections 25a, 25b to show a product sample 60 contained therein.

20 Preferably, each pod 25 is made from a light-weight bio-degradable material. It is also considered that the pods can be of various shapes and sizes including angled and non-uniform shapes in order to better accommodate various shapes of samples 60, but allow for an internal cavity 56 for the sample 60 to sit inside.

Referring now to Fig. 29, there is illustrated an alternate embodiment of the dispensing system of the subject invention, designated generally by reference numeral

25

100, wherein products 113 associated with the samples dispensed by the system are displayed on shelves 123 below the sample access port 116.

While the subject disclosure has been shown and described with reference to preferred embodiments, those skilled in the art will readily appreciate that changes  
5 and/or modifications may be made thereto without departing from the scope of the subject disclosure.

**WHAT IS CLAIMED IS:**

1. A system for dispensing a product sample to a consumer comprising:
  - a) a storage compartment for holding a plurality of product sample containing  
5 spherical pods in a closely-packed assemblage;
  - b) a dispensing area communicating with the storage compartment and including an access port accessible by a consumer to obtain a single spherical pod;
  - c) a dispensing wheel mounted for rotation at least partially within the storage compartment and at least partially within the dispensing area for transferring a  
10 single spherical pod from the storage compartment to the access port; and
  - d) an agitator mounted for movement within the storage compartment to agitate the spherical pods within the storage compartment so as to reduce friction between adjacent spherical pods in the closely-packed assemblage and promote movement of pods from the storage compartment towards the dispensing wheel.  
15
2. A system as recited in Claim 1, further comprising a ramped guide path providing communication between the storage compartment and the dispensing area, wherein the guide path is sloped towards the dispensing wheel.
- 20 3. A system as recited in Claim 2, wherein the dispensing wheel is mounted for rotation about an axis extending perpendicular to the guide path.
4. A system as recited in Claim 2, wherein the dispensing wheel is mounted for rotation in a clock-wise direction.  
25

5. A system as recited in Claim 2, wherein the dispensing wheel has a generally circular configuration and includes a plurality of circumferentially spaced apart pockets, each pocket shaped for receiving a spherical pod delivered from the ramped guide path to the access port.

5

6. A system as recited in Claim 5, wherein the dispensing wheel has a sensing means associated with the plurality of circumferentially spaced apart pockets for detecting reception of a spherical pod within said pocket.

10 7. A system as recited in Claim 1, wherein the agitator is mounted for rotation about an axis extending perpendicular to the guide path.

8. A system as recited in Claim 1, wherein the agitator has a generally elliptical configuration.

15

9. A system as recited in Claim 1, wherein the agitator is mounted for rotation in a clock-wise direction and a counter-clockwise direction.

10. A system as recited in Claim 1, further comprising a first motor for rotating the  
20 dispensing wheel and a second motor for rotating the agitator.

11. A system as recited in Claim 10, further comprising a motor controller for controlling the first and second motors.

12. A system as recited in Claim 11, further comprising means for enabling a consumer to interact with the motor controller in a contact-less manner, using a mobile terminal image processor by way of an image, to enable a transfer of a spherical pod from the storage compartment to the access port in order to collect the spherical pod  
5 from the access port to receive a product sample.

13. A system as recited in Claim 1, wherein a depth of the storage compartment is less than twice a length of a diameter of the spherical pod.

10 14. A system as recited in Claim 1, wherein the storage compartment includes a vertically oriented divider partially bisecting the storage compartment.

15 15. A method of dispensing a product sample to a consumer comprising the steps of:  
a) providing a plurality of spherical pods each containing a product sample  
in a closely-packed assemblage within a storage compartment of an enclosure;

b) agitating the spherical pods within the storage compartment of the enclosure so as to reduce friction between adjacent spherical pods in the closely-packed assemblage and thereby promoting movement of the spherical pods from the storage compartment towards a dispensing area;

20 c) rotating a dispensing wheel adjacent the dispensing area to transfer a single spherical pod from the storage compartment to the access port; and

d) dispensing a spherical pod to a consumer from an access port communicating with the dispensing area.

16. A method according to Claim 15, wherein agitating the spherical pods in the storage compartment of the enclosure involves rotating an agitator mechanism within the storage compartment.

5 17. A method according to Claim 15, wherein agitating the spherical pods includes rotating the agitator mechanism less than 360 degrees in a clockwise direction.

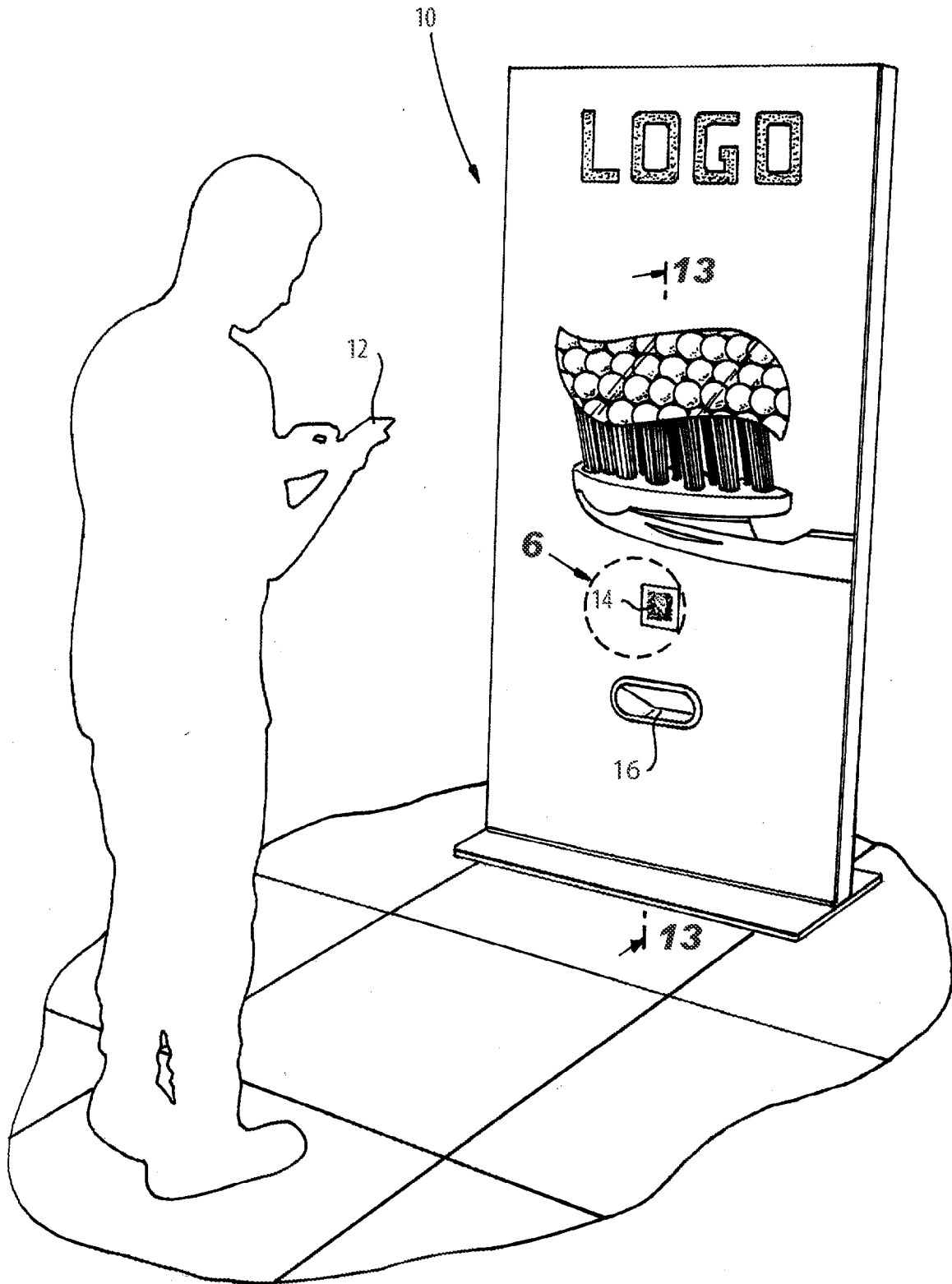
18. A method according to Claim 17, wherein agitating the spherical pods includes rotating the agitator mechanism less than 360 degrees in a counter-clockwise direction.

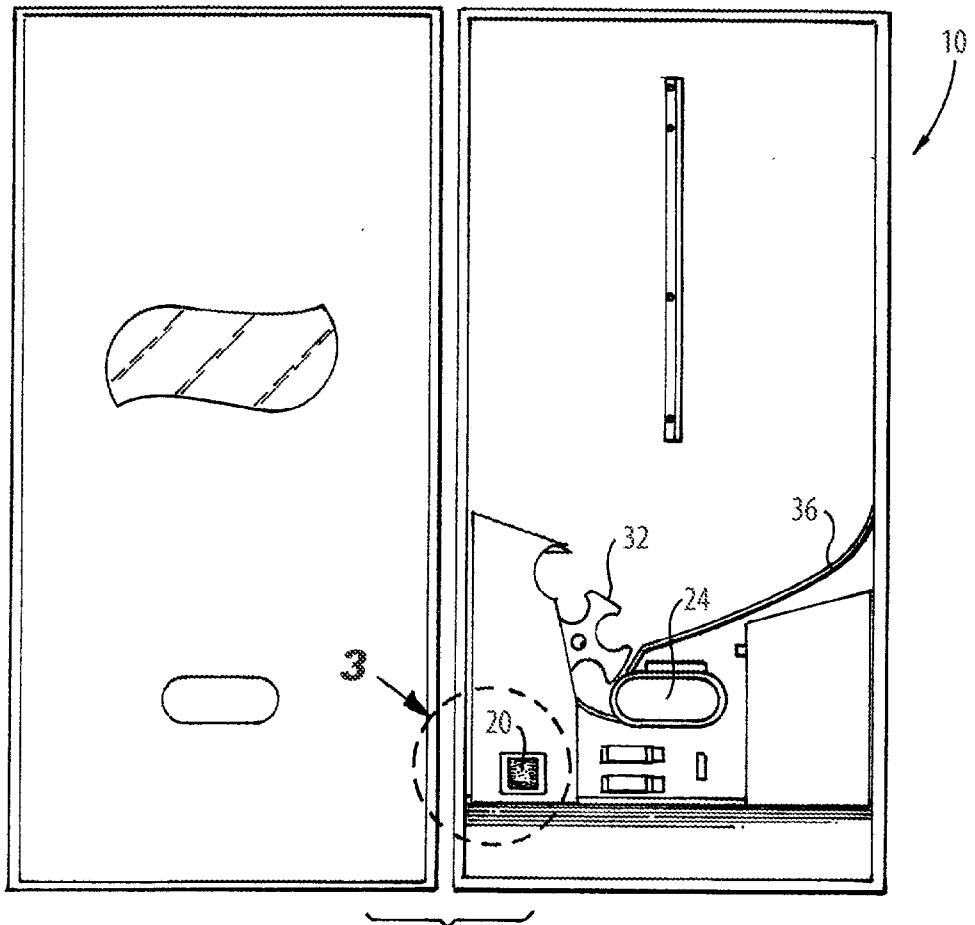
10

19. A method according to claim 18, wherein rotating the dispensing wheels is activated by a signal from a server external to the enclosure.

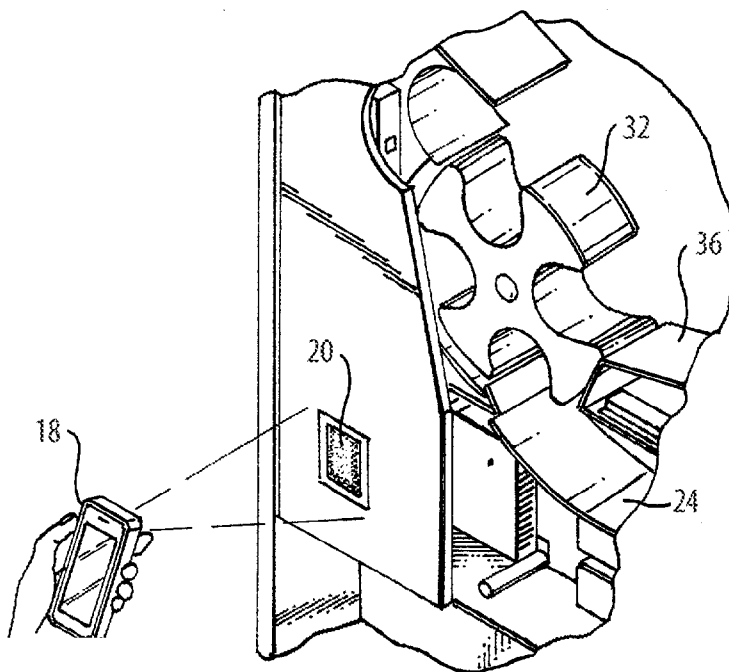
20. A method according to claim 19, wherein a message is sent from a user mobile  
15 terminal used for scanning a visual code on an outside of the enclosure to prompt the signal for activating rotation to be sent.

**Fig. 1**

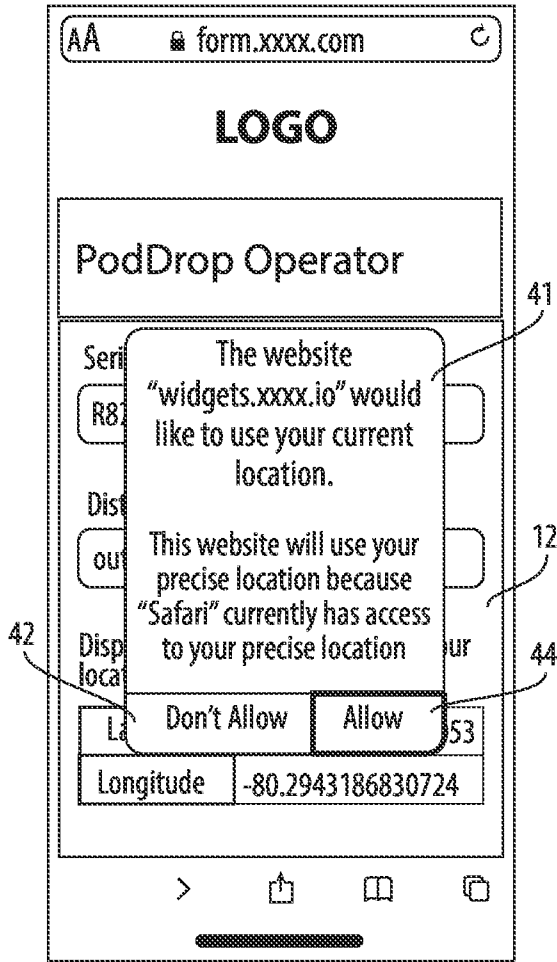




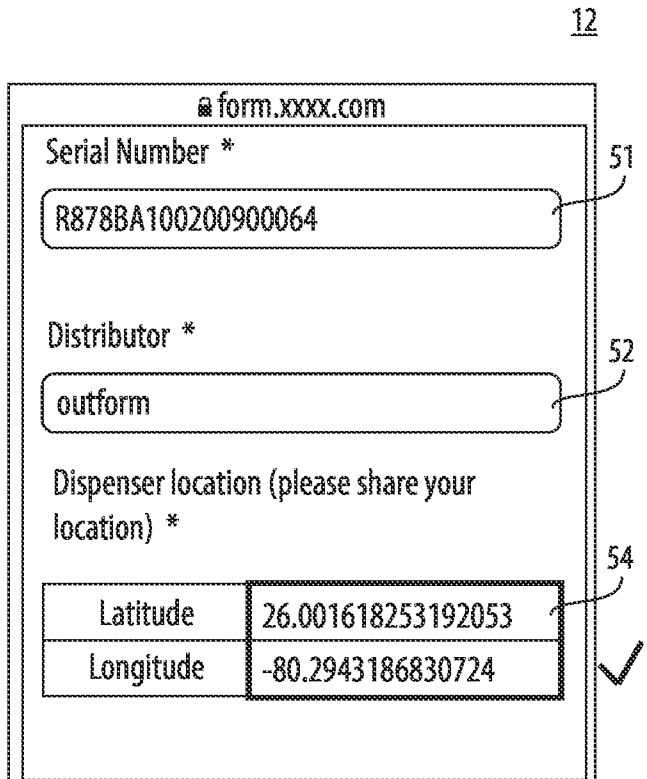
**Fig. 2**



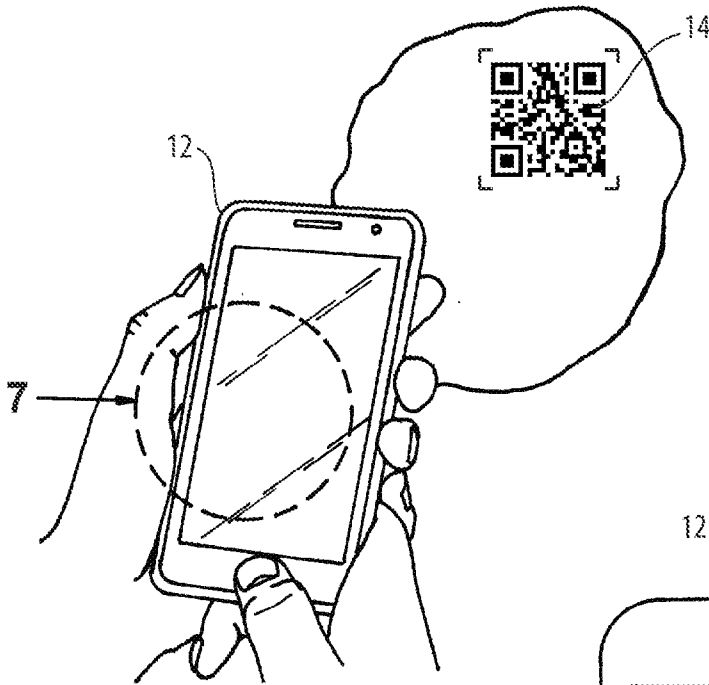
**Fig. 3**



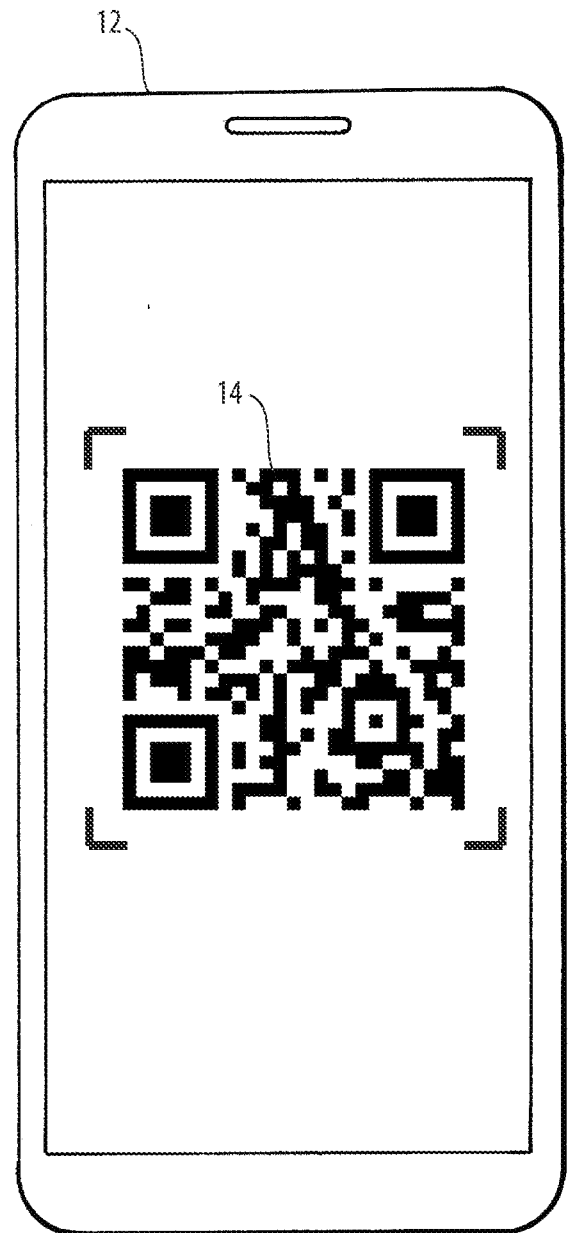
**Fig. 4**



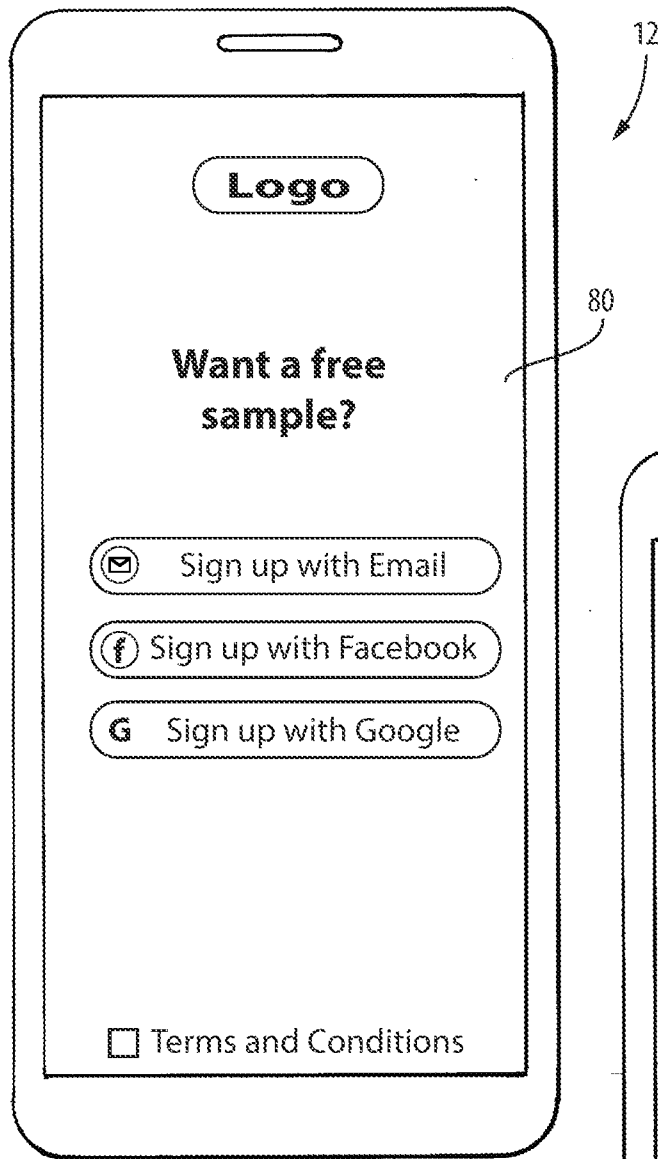
**Fig. 5**



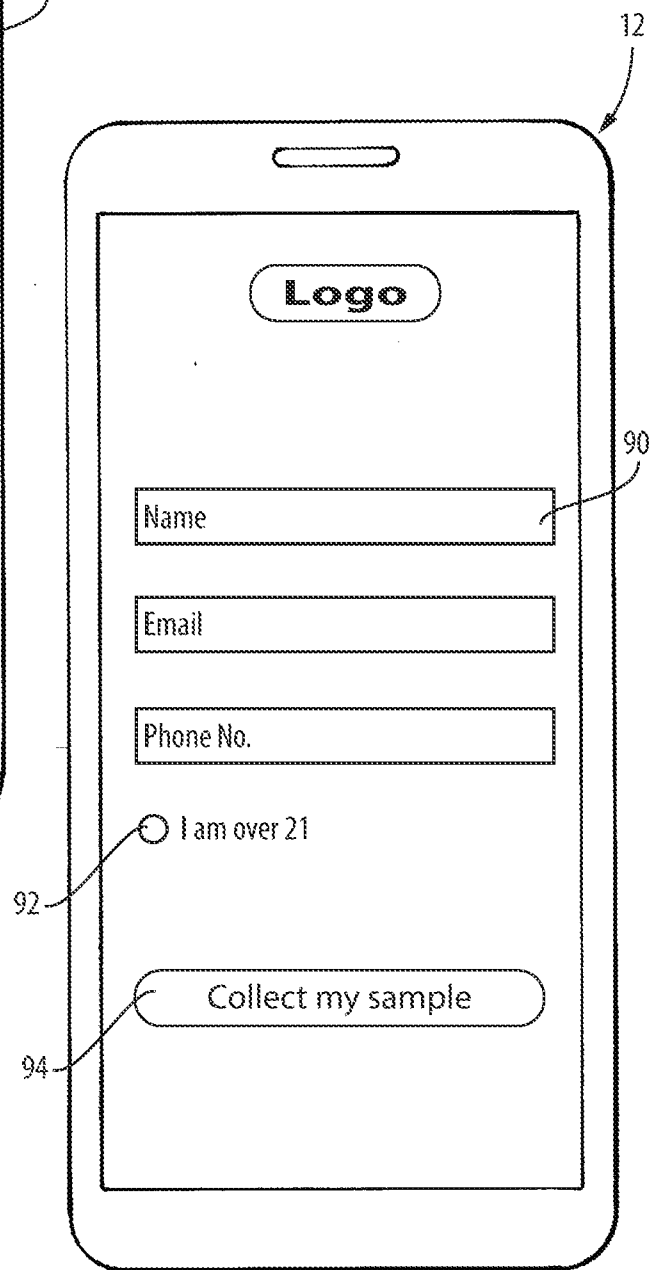
**Fig. 6**



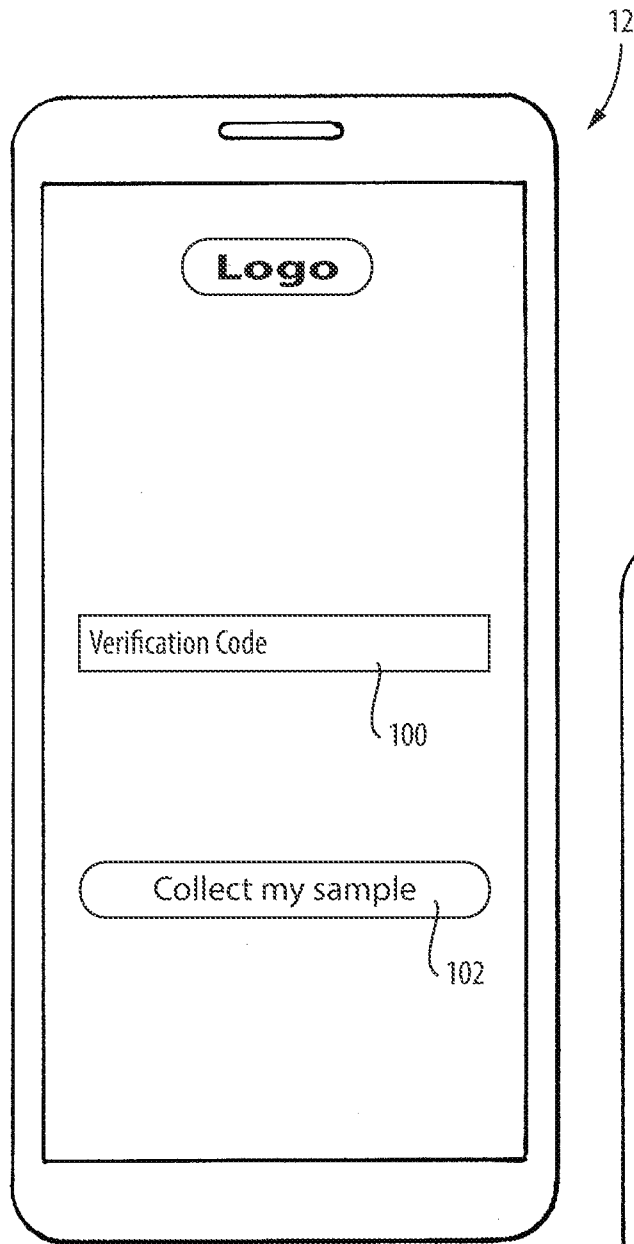
**Fig. 7**



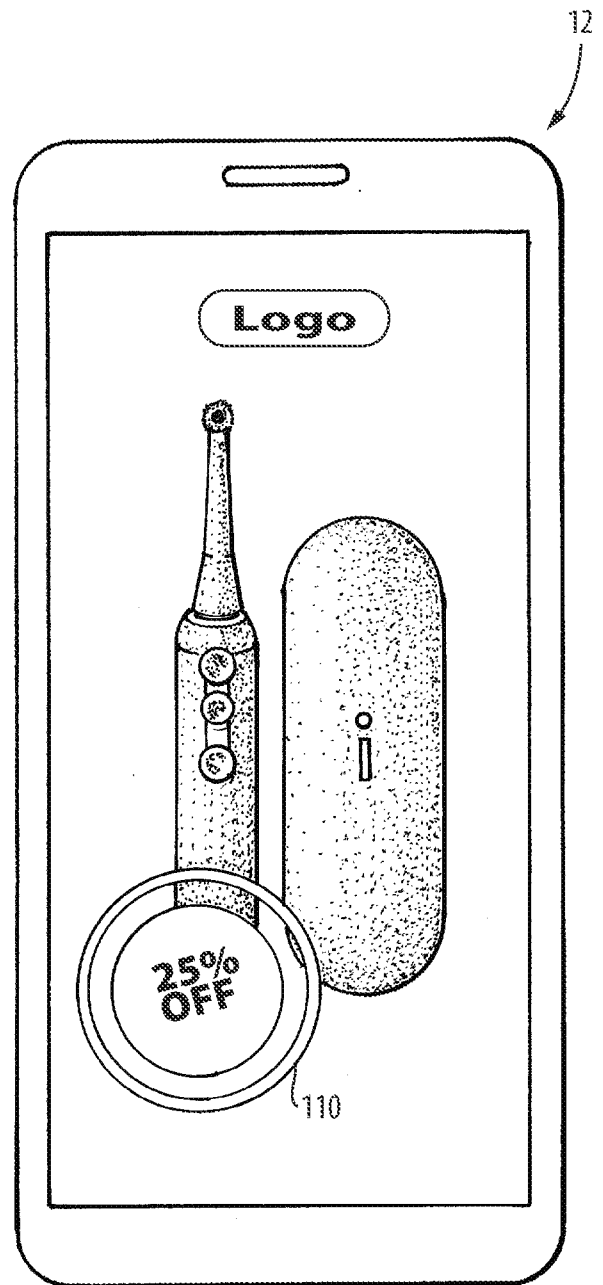
**Fig. 8**



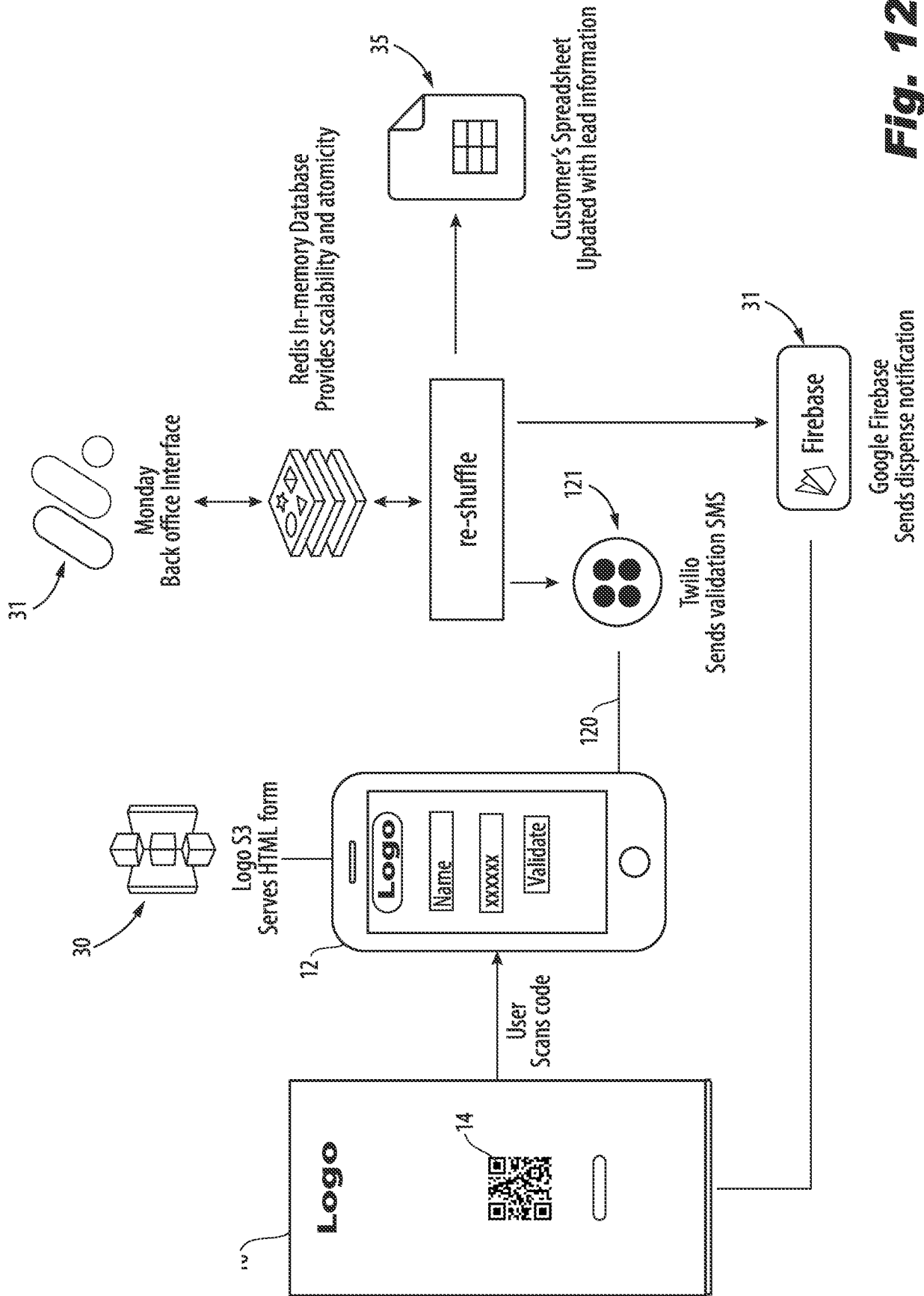
**Fig. 9**



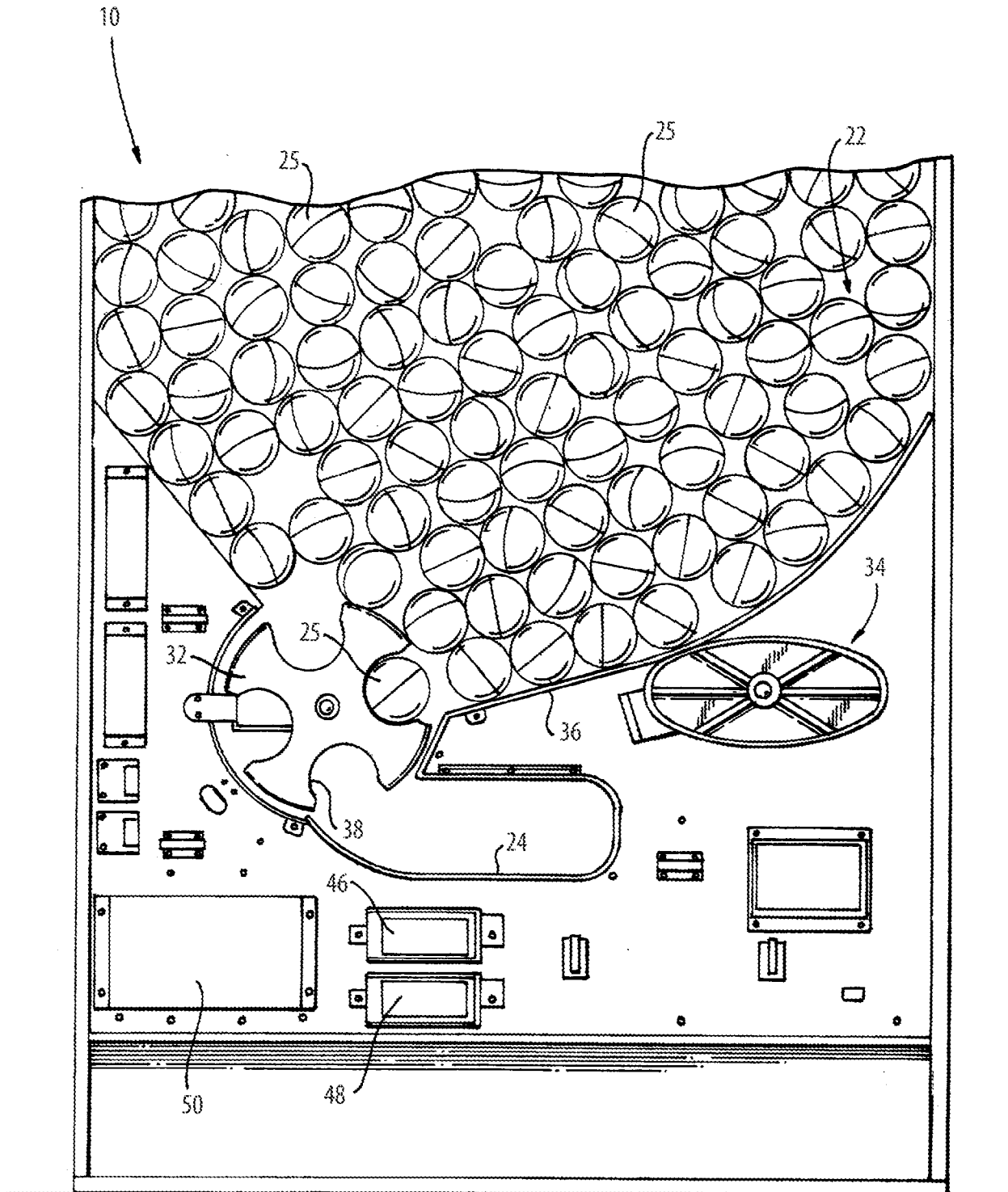
**Fig. 10**



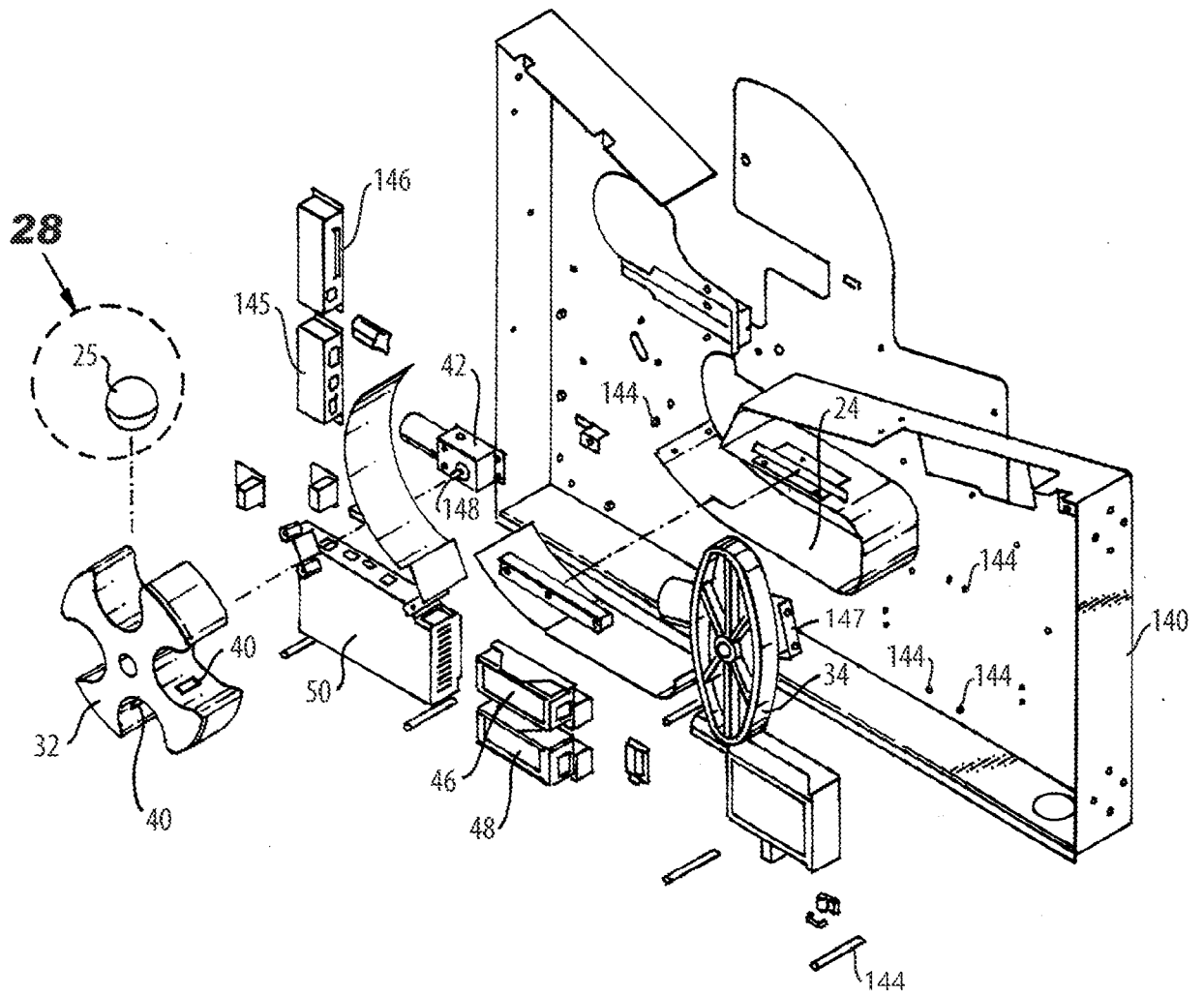
**Fig. 11**



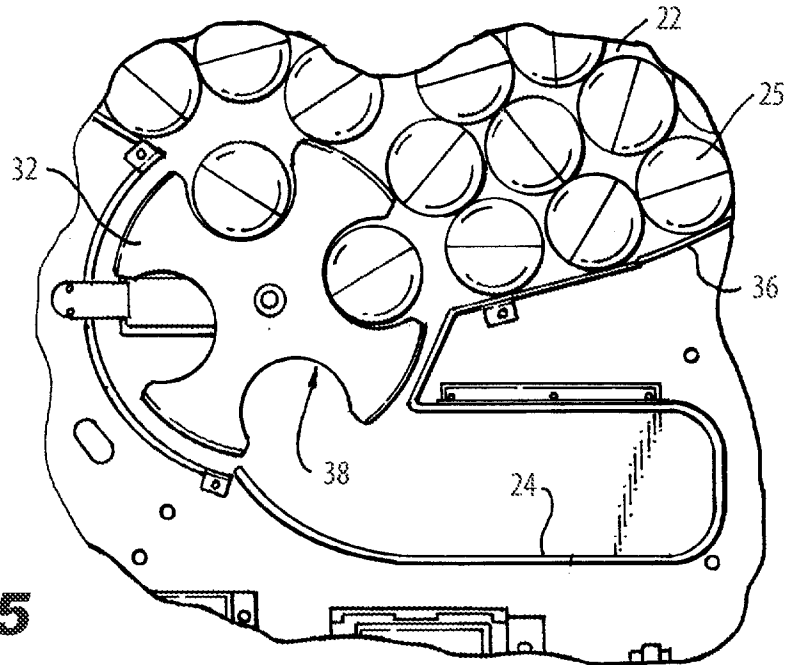
**Fig. 12**



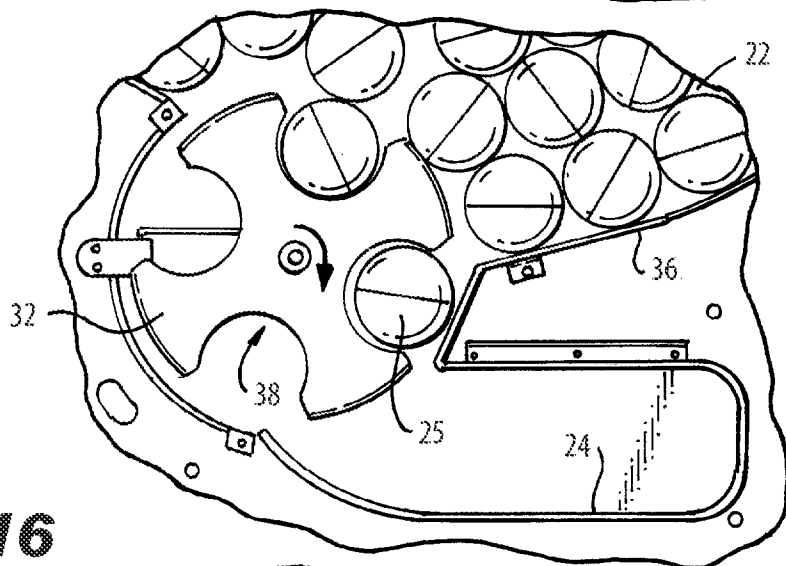
**Fig. 13**



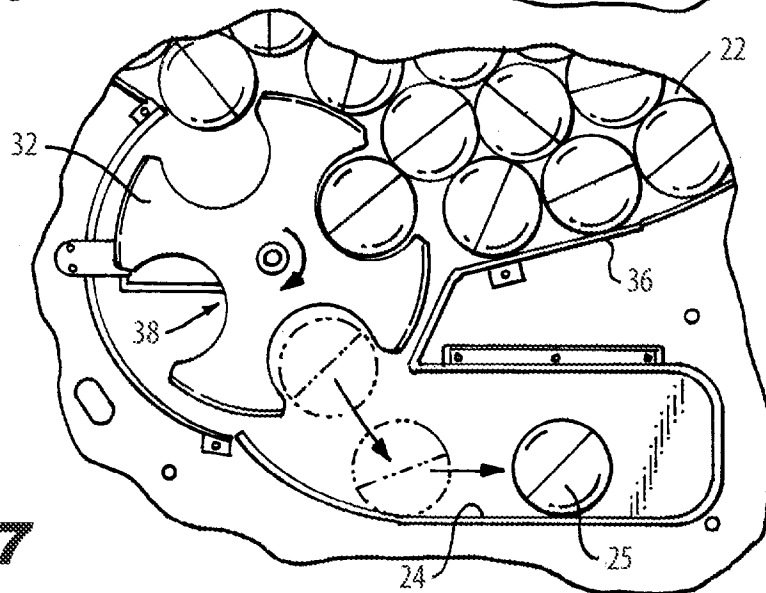
**Fig. 14**



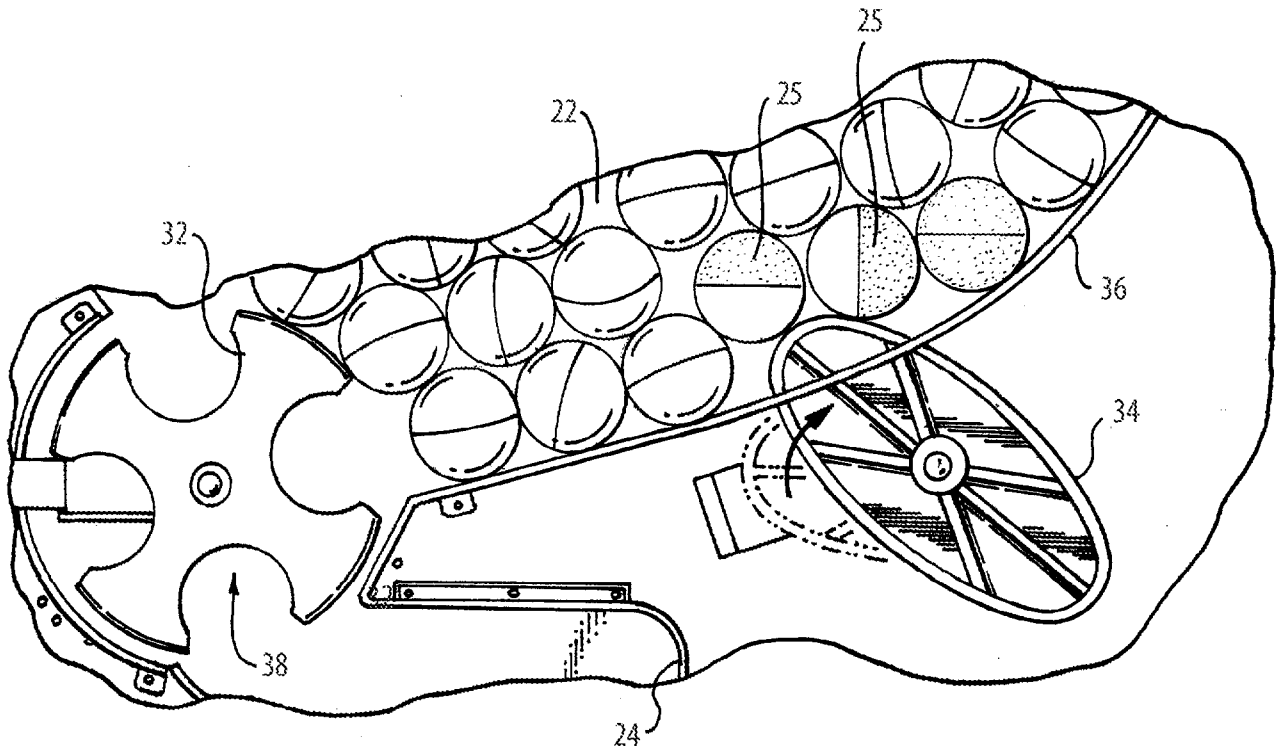
**Fig. 15**



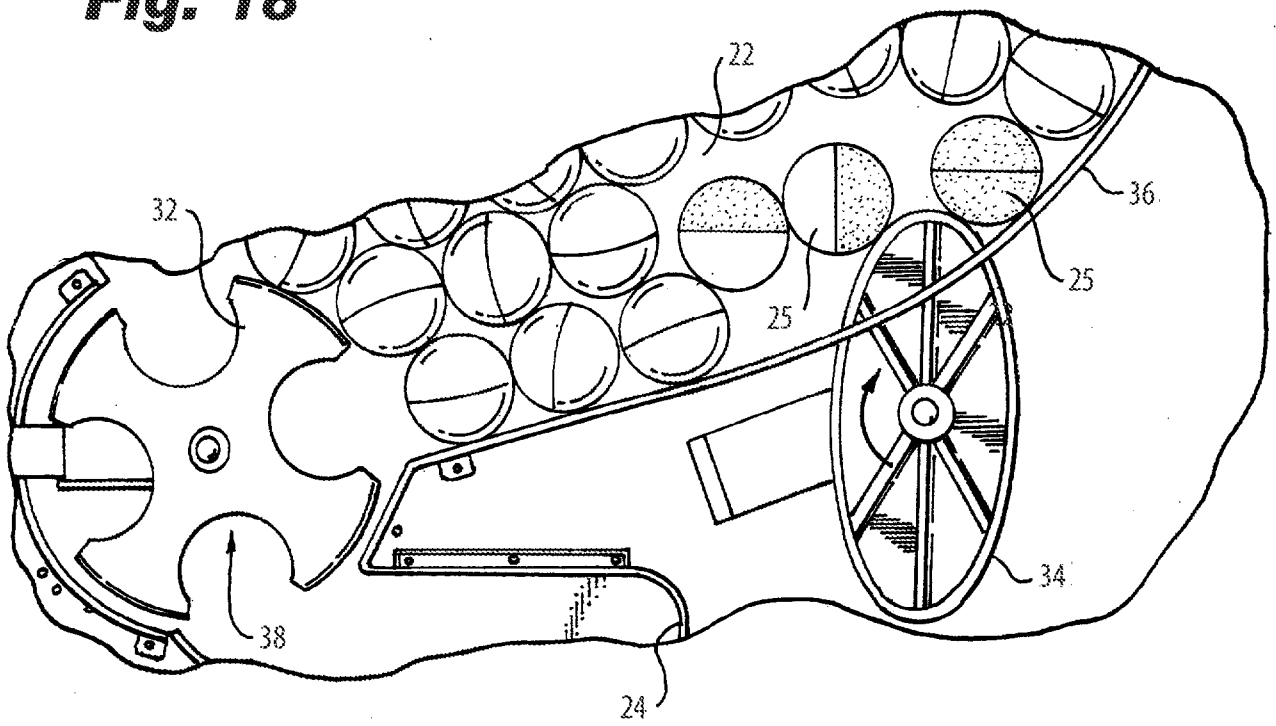
**Fig. 16**



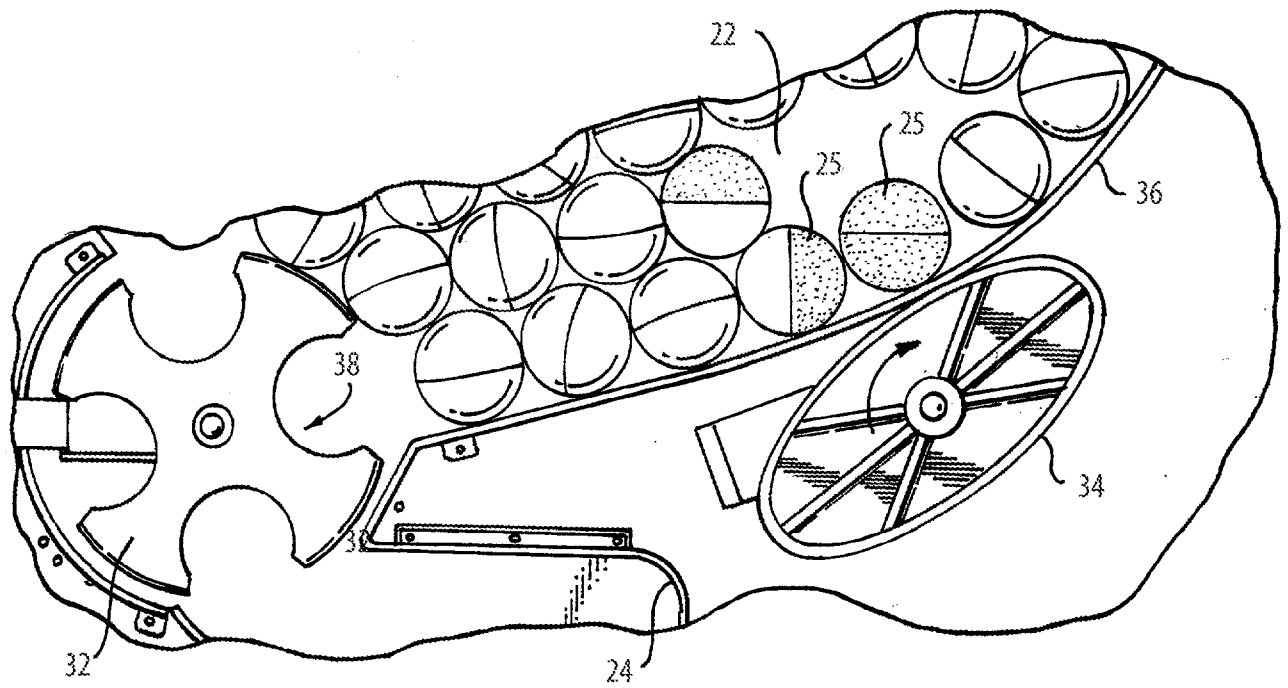
**Fig. 17**



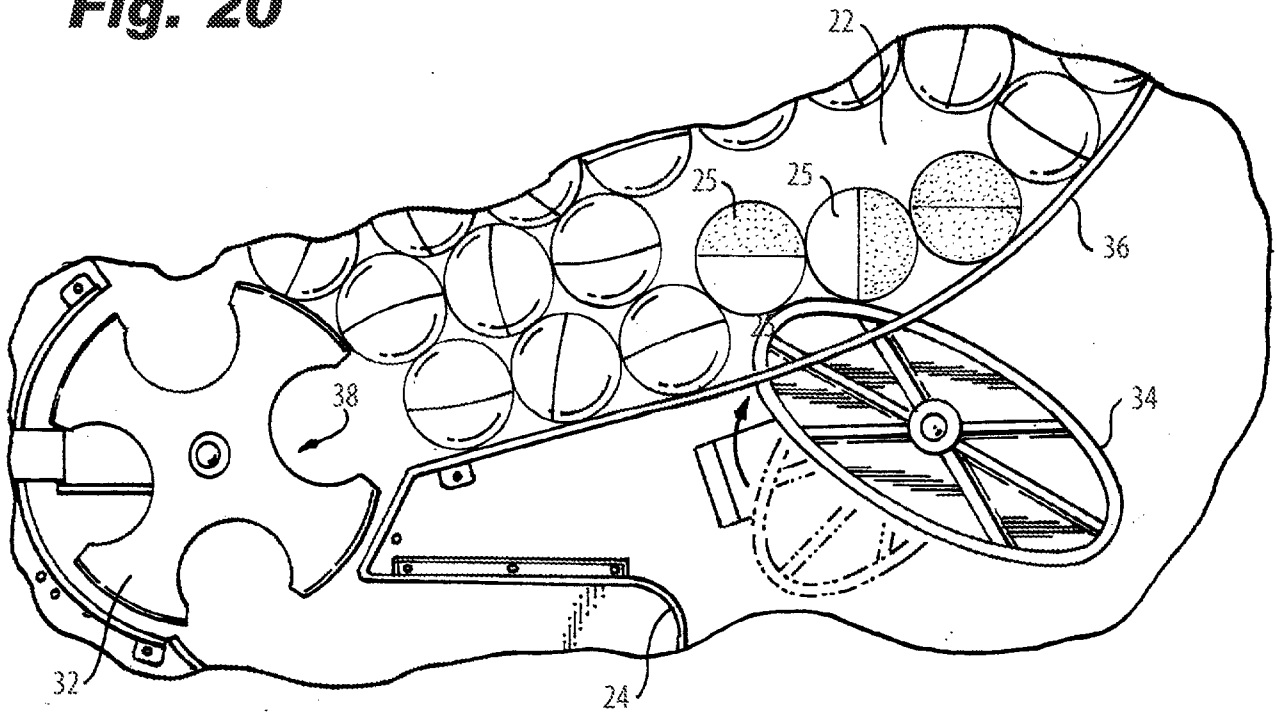
**Fig. 18**



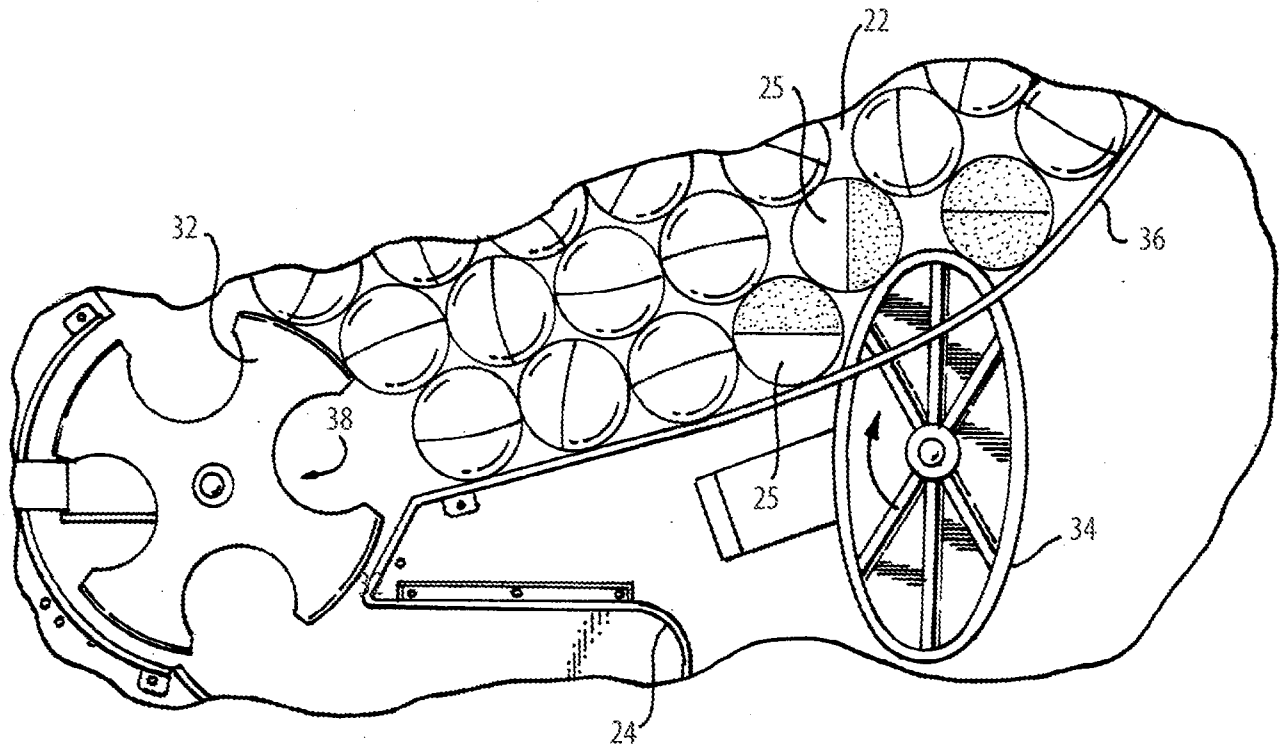
**Fig. 19**



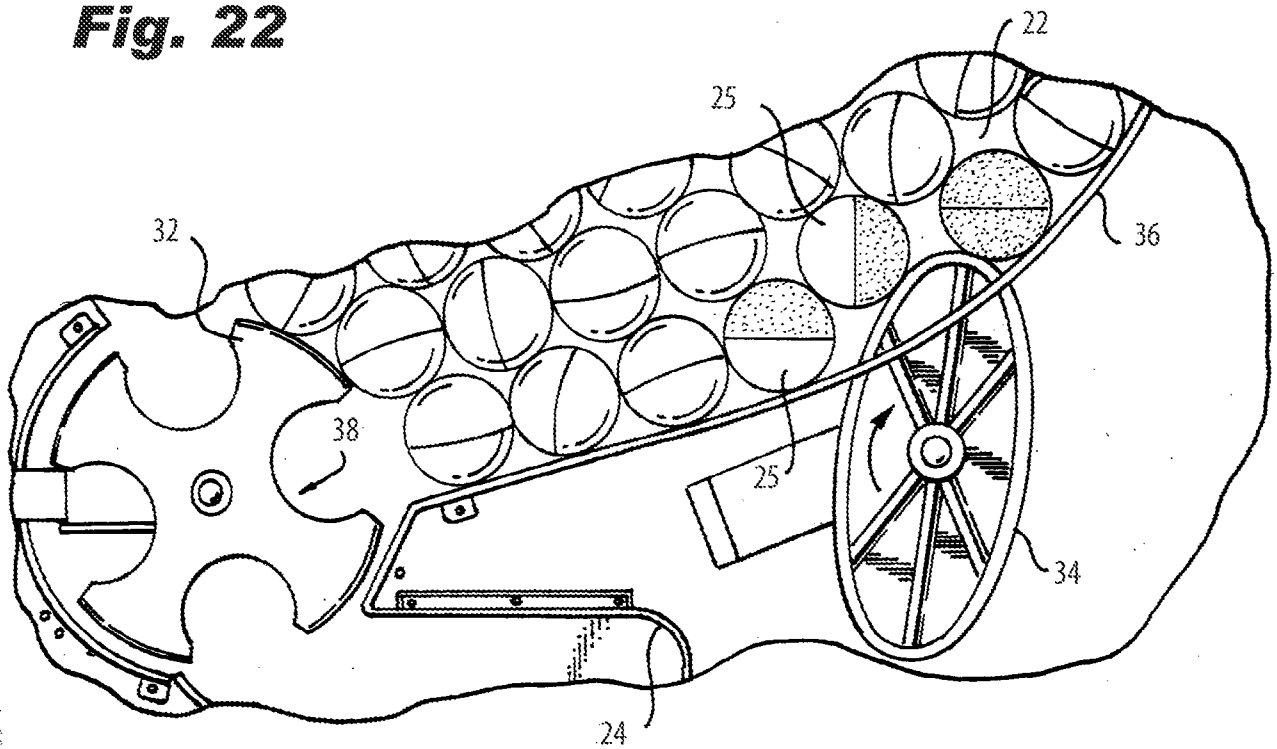
**Fig. 20**



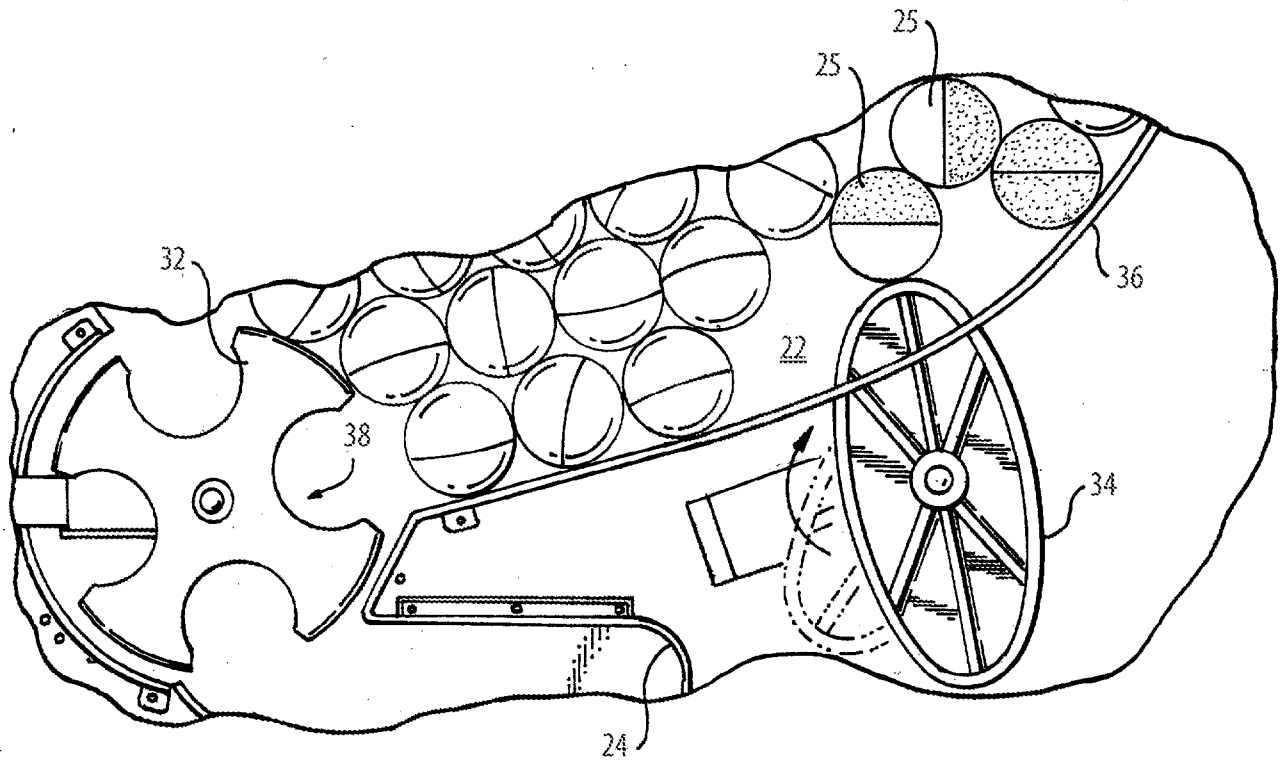
**Fig. 21**



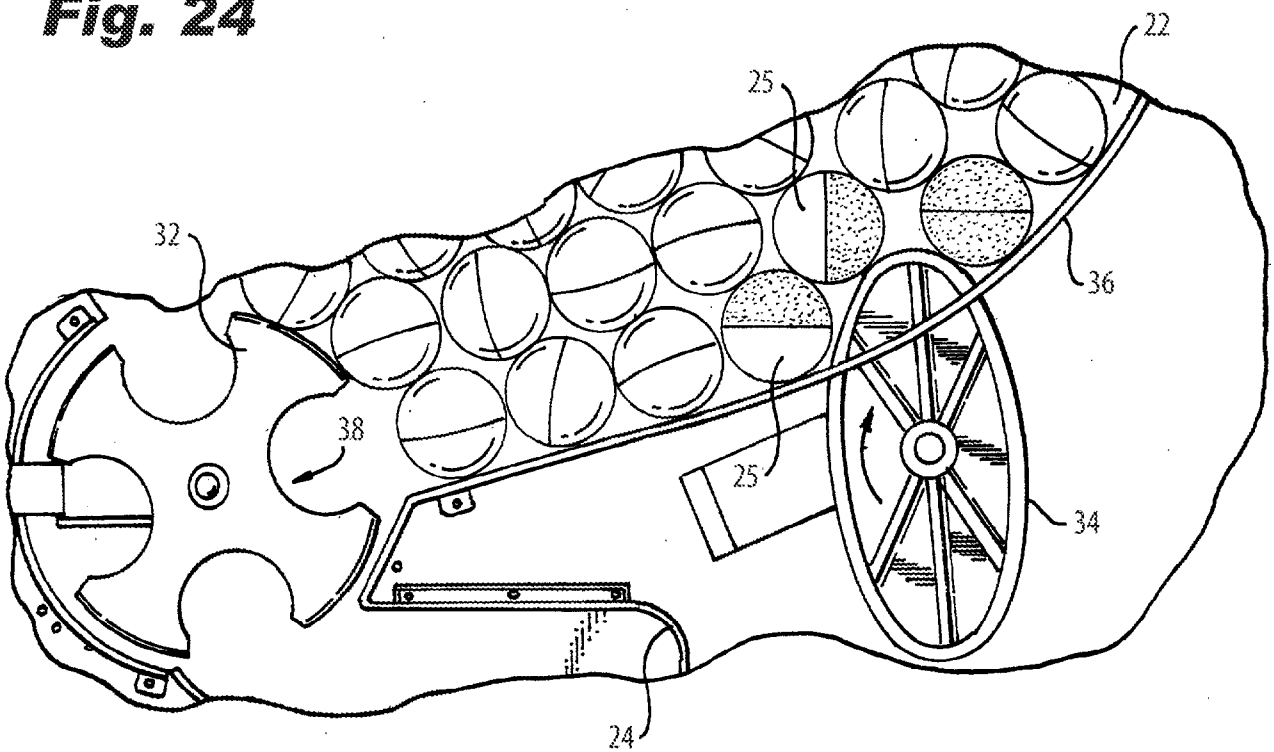
**Fig. 22**



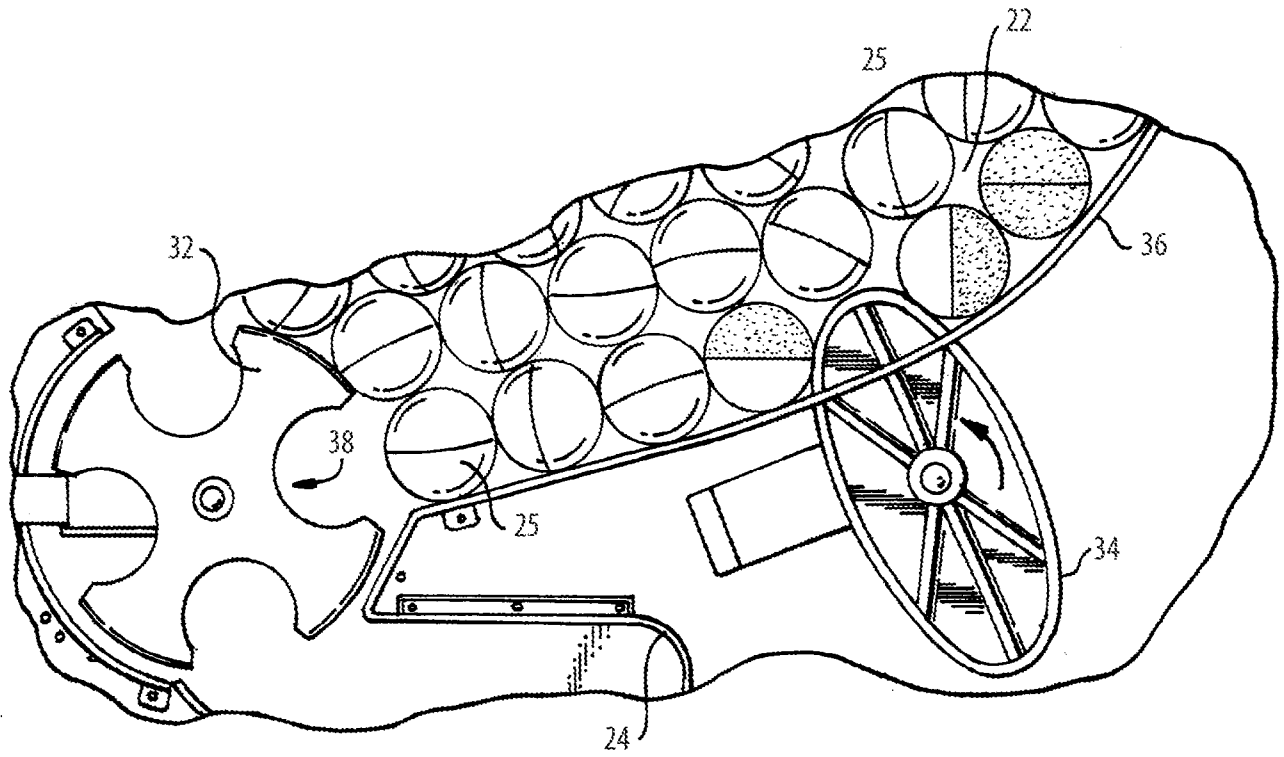
**Fig. 23**



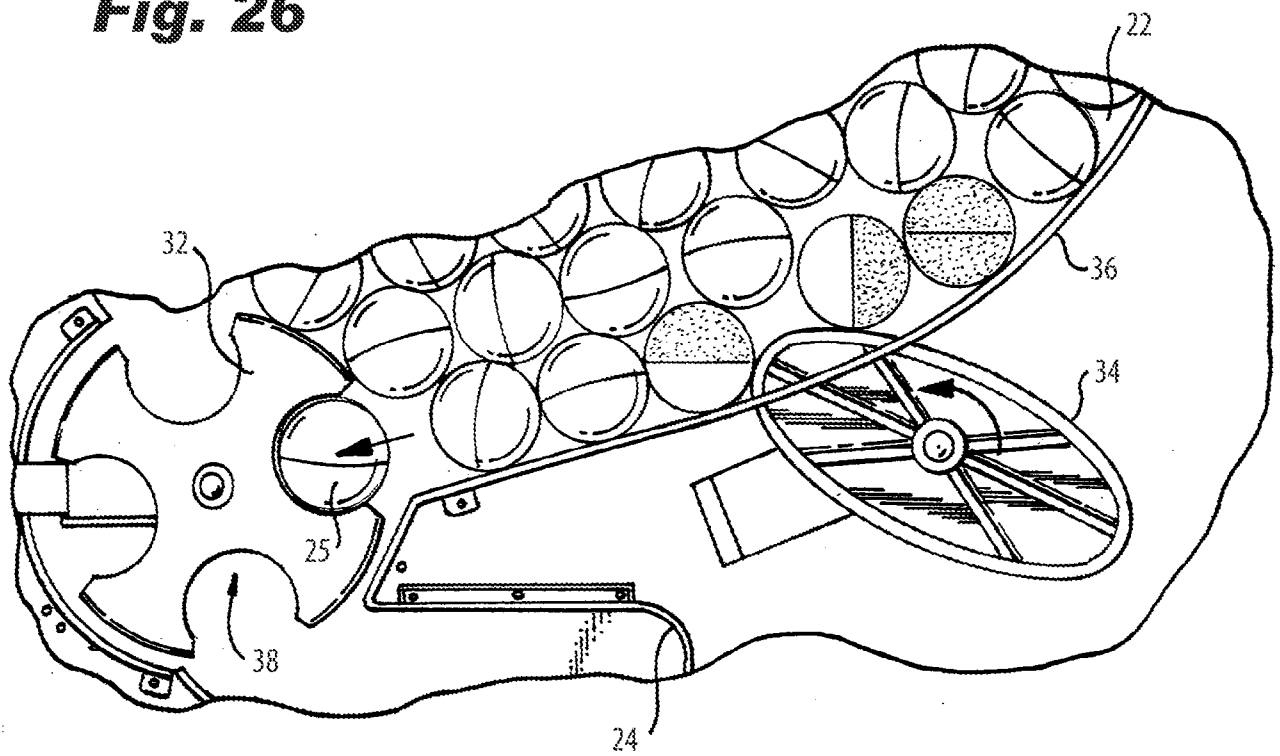
**Fig. 24**



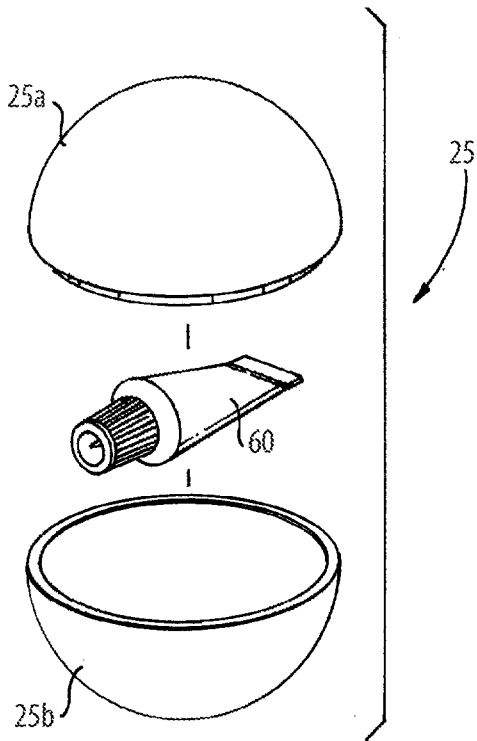
**Fig. 25**



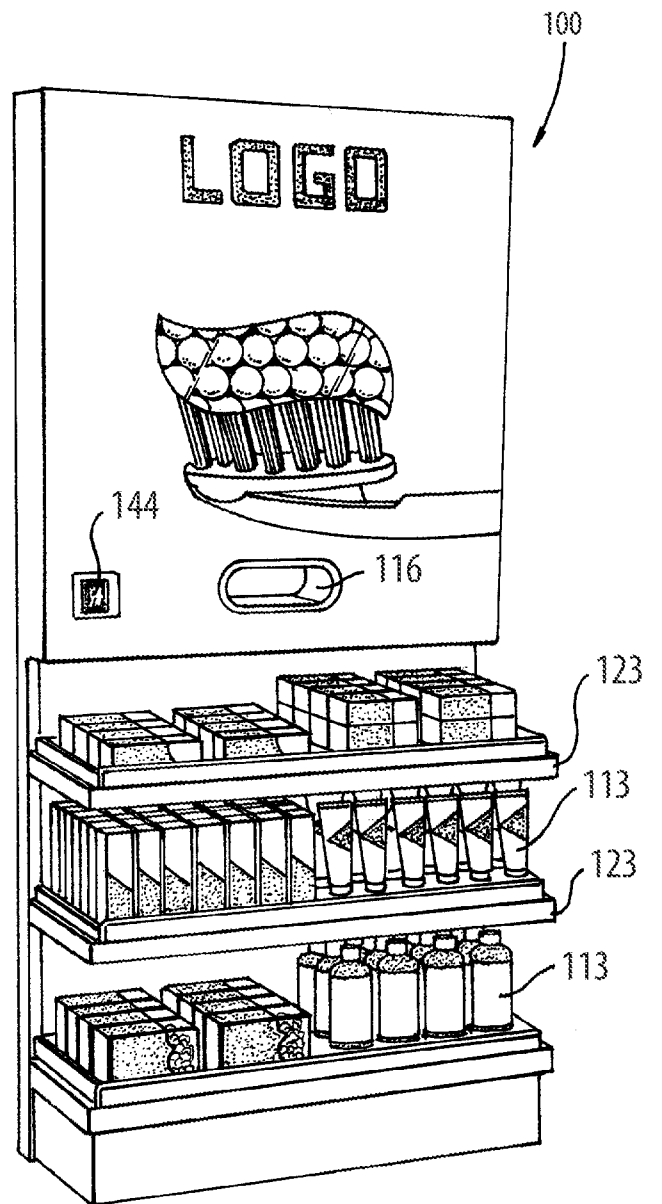
**Fig. 26**



**Fig. 27**



**Fig. 28**



**Fig. 29**

INTERNATIONAL SEARCH REPORT

International application No.

PCT/IB21/00820

A. CLASSIFICATION OF SUBJECT MATTER

IPC - G07F 17/32; G07F 11/44; G07F 11/42; G07F 11/24; B65D 83/04 (2021.01)

CPC - B65D 83/0409; A63B 47/002; B65D 83/0083; G07F 11/005; G07F 11/24; G07F 11/42; G07F 11/44; G07F 17/32; G07F 17/0092

According to International Patent Classification (IPC) or to both national classification and IPC

B. FIELDS SEARCHED

Minimum documentation searched (classification system followed by classification symbols)

See Search History document

Documentation searched other than minimum documentation to the extent that such documents are included in the fields searched

See Search History document

Electronic data base consulted during the international search (name of data base and, where practicable, search terms used)

See Search History document

C. DOCUMENTS CONSIDERED TO BE RELEVANT

Category*	Citation of document, with indication, where appropriate, of the relevant passages	Relevant to claim No.
X --- Y --- A	US 2011/0295416 A1 (AQUILONIUS, SM et. al) 01 December 2011; figures 1, 4; paragraphs [0057], [0059], [0060], [0081], [0143]	1-5 --- 13, 14 --- 6-12
Y	US 5,351,858 A (BAR-YONA, I et. al) 04 October 1994; figures 1, 4; column 3, lines 5-10	13
Y --- A	WO 02058528 A1 (UNILEVER PLC) 01 August 2002; column 11, lines 1-2; figures 3A, C	14 --- 6
A	US 5,860,563 A (GUERRA, LE et. al) 19 January 1999; column 4, lines 40-45	1-14
A	US 2016/0244267 A1 (BEAVER MACHINE CORPORATION) 25 August 2016; paragraph [0039]	1-14
A	US 6,695,698 B1 (ANGHELO, P et. al) 24 February 2004; column 2, lines 17-25	1-14
A	US 1,976,351 A (MATTHIESEN, JC) 09 October 1934; entire document	1-14
A	US 2016/0377376 A1 (DONMARK HOLDINGS INC.) 29 December 2016; entire document	1-14
A	US 2,627,973 A (SINES, WV) 10 February 1953; entire document	1-14

Further documents are listed in the continuation of Box C.  See patent family annex.

* Special categories of cited documents:	"T" later document published after the international filing date or priority date and not in conflict with the application but cited to understand the principle or theory underlying the invention
"A" document defining the general state of the art which is not considered to be of particular relevance	"X" document of particular relevance; the claimed invention cannot be considered novel or cannot be considered to involve an inventive step when the document is taken alone
"D" document cited by the applicant in the international application	"Y" document of particular relevance; the claimed invention cannot be considered to involve an inventive step when the document is combined with one or more other such documents, such combination being obvious to a person skilled in the art
"E" earlier application or patent but published on or after the international filing date	"&" document member of the same patent family
"L" document which may throw doubts on priority claim(s) or which is cited to establish the publication date of another citation or other special reason (as specified)	
"O" document referring to an oral disclosure, use, exhibition or other means	
"P" document published prior to the international filing date but later than the priority date claimed	

Date of the actual completion of the international search

14 April 2022 (14.04.2022)

Date of mailing of the international search report

MAY 06 2022

Name and mailing address of the ISA/US

Mail Stop PCT, Attn: ISA/US, Commissioner for Patents  
P.O. Box 1450, Alexandria, Virginia 22313-1450  
Facsimile No. 571-273-8300

Authorized officer

Shane Thomas

Telephone No. PCT Helpdesk: 571-272-4300

INTERNATIONAL SEARCH REPORT

International application No.

PCT/IB21/00820

C (Continuation). DOCUMENTS CONSIDERED TO BE RELEVANT

Category*	Citation of document, with indication, where appropriate, of the relevant passages	Relevant to claim No.
A	US 4,300,703 A (LAUNAY, N) 17 November 1981; entire document	1-14

**INTERNATIONAL SEARCH REPORT**

International application No.

PCT/IB21/00820

**Box No. II Observations where certain claims were found unsearchable (Continuation of item 2 of first sheet)**

This international search report has not been established in respect of certain claims under Article 17(2)(a) for the following reasons:

1.  Claims Nos.:  
because they relate to subject matter not required to be searched by this Authority, namely:
  
2.  Claims Nos.:  
because they relate to parts of the international application that do not comply with the prescribed requirements to such an extent that no meaningful international search can be carried out, specifically:
  
3.  Claims Nos.:  
because they are dependent claims and are not drafted in accordance with the second and third sentences of Rule 6.4(a).

**Box No. III Observations where unity of invention is lacking (Continuation of item 3 of first sheet)**

This International Searching Authority found multiple inventions in this international application, as follows:  
-\*\*\*-Please See Supplemental Page-\*\*\*-

1.  As all required additional search fees were timely paid by the applicant, this international search report covers all searchable claims.
2.  As all searchable claims could be searched without effort justifying additional fees, this Authority did not invite payment of additional fees.
3.  As only some of the required additional search fees were timely paid by the applicant, this international search report covers only those claims for which fees were paid, specifically claims Nos.:
4.  No required additional search fees were timely paid by the applicant. Consequently, this international search report is restricted to the invention first mentioned in the claims; it is covered by claims Nos.:  
Group I: Claims 1-14

- Remark on Protest**
- The additional search fees were accompanied by the applicant's protest and, where applicable, the payment of a protest fee.
  - The additional search fees were accompanied by the applicant's protest but the applicable protest fee was not paid within the time limit specified in the invitation.
  - No protest accompanied the payment of additional search fees.

-\*\*\*-Continued From Box No. III: Observations where unity of invention is lacking-\*\*\*-

This application contains the following inventions or groups of inventions which are not so linked as to form a single general inventive concept under PCT Rule 13.1. In order for all inventions to be examined, the appropriate additional examination fees must be paid.

Group I: Claims 1-14 are directed toward a system for dispensing a product sample to a consumer comprising: c) a dispensing wheel mounted for rotation at least partially within the storage compartment and at least partially within the dispensing area; and d) an agitator mounted for movement within the storage compartment.

Group II: Claims 15-20 are directed toward a method of dispensing a product sample to a consumer comprising the steps of: a) providing a plurality of spherical pods each containing a product sample within a storage compartment of an enclosure; and d) dispensing a spherical pod to a consumer from an access port communicating with the dispensing area.

The inventions listed as Groups I-II do not relate to a single general inventive concept under PCT Rule 13.1 because, under PCT Rule 13.2, they lack the same or corresponding special technical features for the following reasons:

Group I include a system for dispensing a product sample to a consumer comprising: c) a dispensing wheel mounted for rotation at least partially within the storage compartment and at least partially within the dispensing area; and d) an agitator mounted for movement within the storage compartment to promote movement of pods from the storage compartment towards the dispensing wheel (which are not present in Group II).

Group II include a method of dispensing a product sample to a consumer comprising the steps of: a) providing a plurality of spherical pods each containing a product sample in a closely-packed assemblage within a storage compartment of an enclosure; c) rotating a dispensing wheel adjacent the dispensing area; and d) dispensing a spherical pod to a consumer from an access port communicating with the dispensing area (which are not present in Group I).

The common technical features of Groups I and II are a system/method for a product sample to a consumer comprising: a) a storage compartment for holding a plurality of product sample containing spherical pods in a closely-packed assemblage; b) a dispensing area communicating with the storage compartment and including an access port accessible by a consumer to obtain a single spherical pod; c) a dispensing wheel for transferring a single spherical pod from the storage compartment to the access port; d) agitating within the storage compartment so as to reduce friction between adjacent spherical pods in the closely-packed assemblage.

These common technical features are disclosed by US 4,300,703 A (LAUNAY). Launay discloses a system/method for a product sample to a consumer (apparatus for distributing pseudo spherical object, capable of dispensing a product sample to a consumer; abstract; figures 1a-2) comprising: a) a storage compartment for holding a plurality of product sample containing spherical pods in a closely-packed assemblage (hopper 1 for holding the pseudo spherical objects, capable of holding product sample containing spherical pods; abstract; figures 1a-2); b) a dispensing area communicating with the storage compartment and including an access port accessible by a consumer to obtain a single spherical pod (the pseudo spherical object is ejected through a lower opening of the hopper 1, capable of dispensing to a consumer; abstract; figures 1a-2); c) a dispensing wheel for transferring a single spherical pod from the storage compartment to the access port (tube 3 is rotatable for ejecting the pseudo spherical object that has been ejected through the lower opening of the hopper; abstract; figures 1a-2); d) agitating within the storage compartment so as to reduce friction between adjacent spherical pods in the closely-packed assemblage (agitation of the pseudo spherical objects container in the hopper to prevent development of arches in the objects and so reduces friction between the objects; abstract; column 6, lines 20-30).

Since the common technical features are previously disclosed by the Launay reference, the common features are not special and so Groups I and II lack unity.