



(19) **United States**

(12) **Patent Application Publication**

(10) **Pub. No.: US 2004/0025276 A1**

Tsai

(43) **Pub. Date:**

Feb. 12, 2004

(54) **POWDER PUFF**

(52) **U.S. Cl.** 15/229.14

(76) **Inventor:** **Mona Tsai, Sungshan Chiu (TW)**

(57) **ABSTRACT**

Correspondence Address:

RABIN & BERDO, P.C.

Suite 500

1101 14th Street, N.W.

Washington, DC 20005 (US)

(21) **Appl. No.:** **10/212,880**

(22) **Filed:** **Aug. 7, 2002**

Publication Classification

(51) **Int. Cl.⁷** **A45D 33/34**

The powder puff of the present invention comprising of a surface cloth, a foamed plastic and a powder bag. The surface cloth wraps the foamed plastic and the powder bag. The powder of the powder bag can be released from the surface cloth by patting the powder puff lightly and the powder can be spread on the user's face evenly. Besides, the present invention doesn't need to obtain the powder from the powder case. The present invention is more convenient in using and carrying.

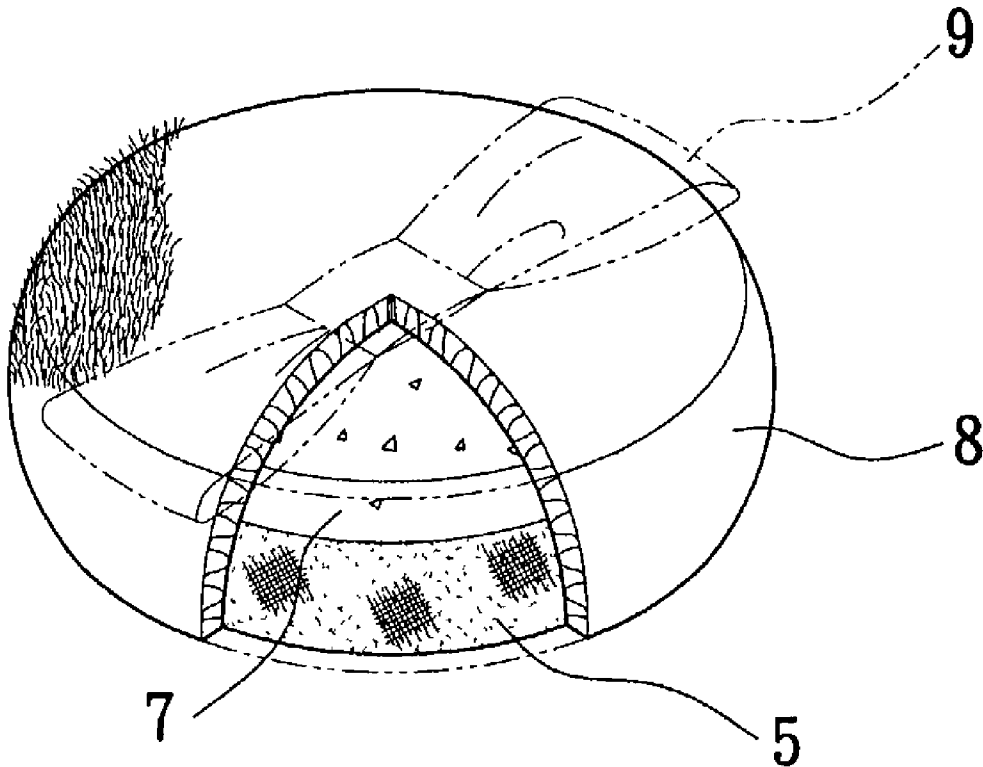

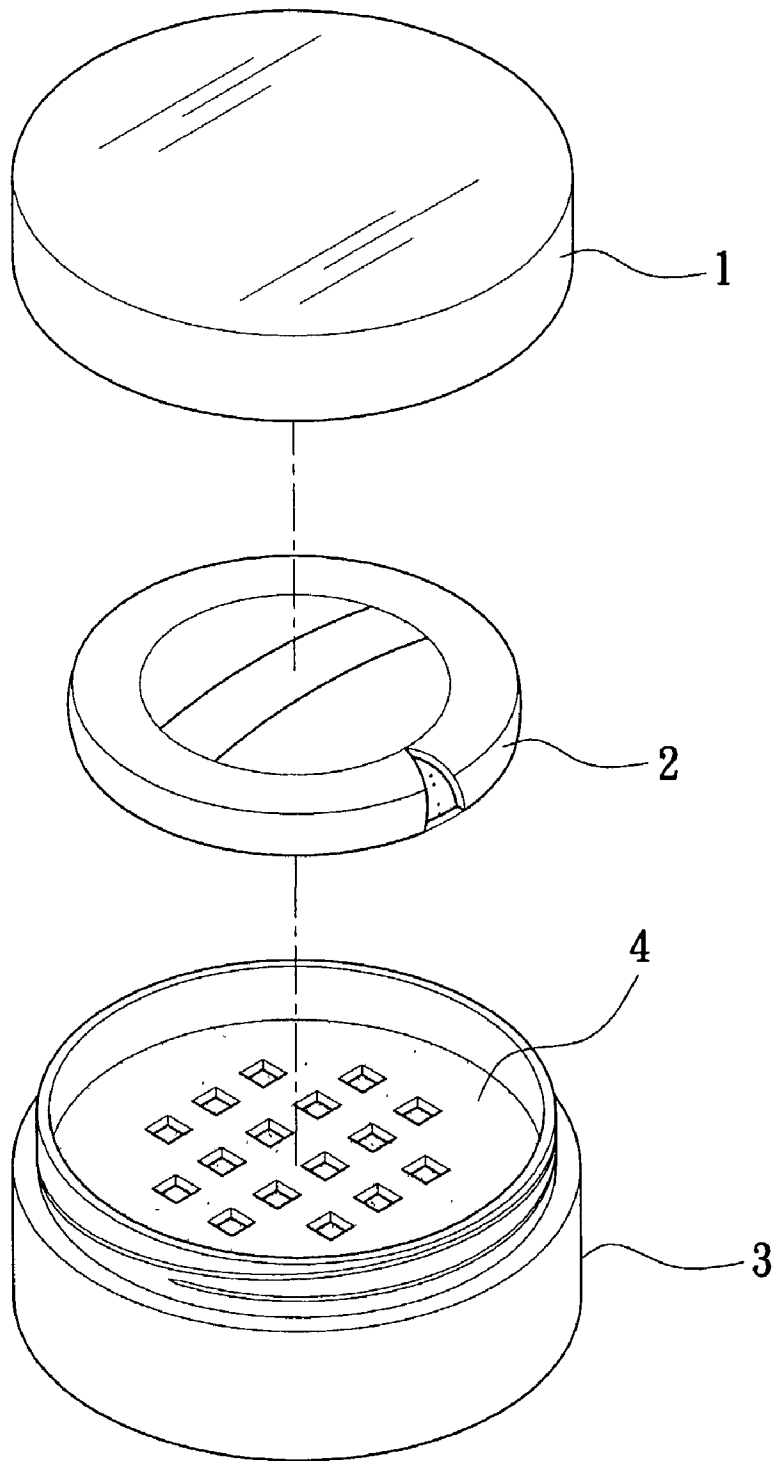

(PRIOR ART)
Fig. 1

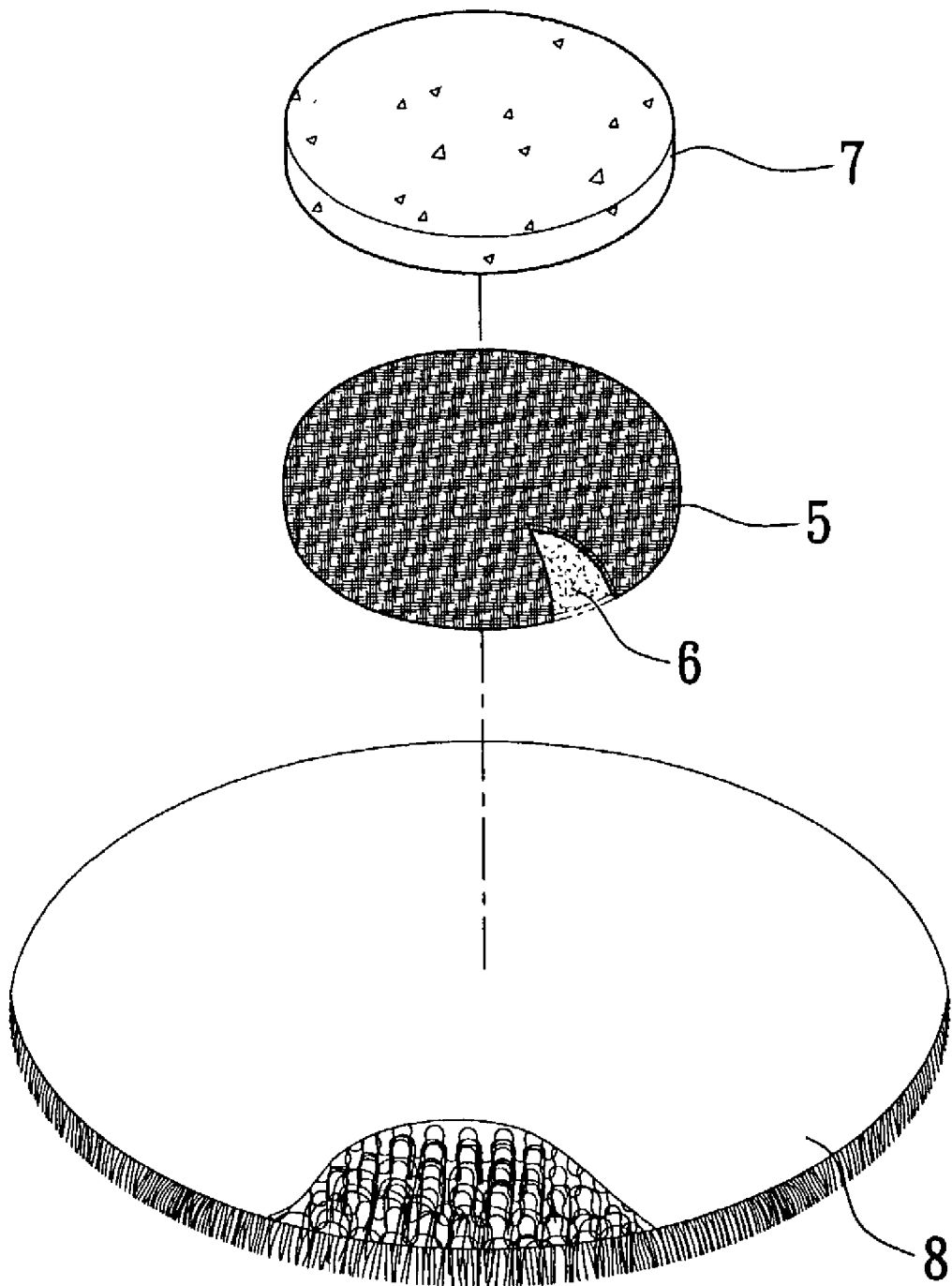

Fig. 2

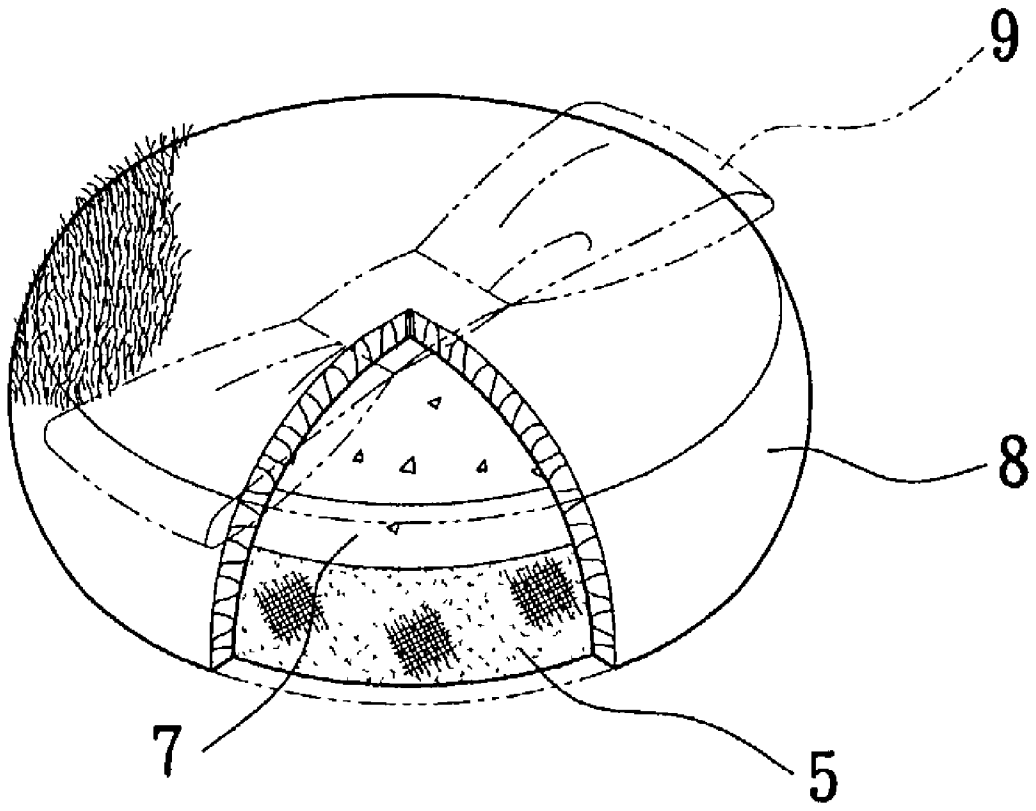

Fig. 3

POWDER PUFF

BACKGROUND OF THE INVENTION

[0001] 1. Field of the Invention

[0002] The present invention relates to a powder puff, which has a powder bag inside. The users pat the powder puff lightly and then the powder released from the powder bag outside to the surface cloth. The powder can be spread on the user's face evenly and doesn't disperse everywhere.

[0003] 2. Description of the Prior Art

[0004] In the present day, women usually make up with powder puff. Please refer to **FIG. 1** that is the prior powder puff. As shown, the prior powder puff is composed of a lid **1**, a powder puff **2** and a powder case **3**. First, pressing the powder puff **2** on the powder case **3**, which has a sieve **4**, and then the powder obtained on the powder puff **2**. Secondly, to fold the powder puff **2** and knead it and then the powder can disperse into the powder puff **2**. Next, patting the powder puff **2** pat on the back of the hand lightly. The surplus powder can be wasted by this way. Besides, to make sure the quantity of the powder is suitable. Finally, patting the powder puff **2** pat on the face lightly. The quantity of the powder is enough and the powder released from the powder puff **2** evenly. Because of this, the powder can be spread on the face evenly and can beautify the face.

[0005] Because people press the powder puff **2** on the powder case **3** that has a sieve **4**, the powder on the powder puff **2** are unequal. The powder is only on the particular place of the powder puff **2** that touches with the mesh of the sieve **4**. If there lack this procedure that to fold the powder puff **2** and knead it, the powder doesn't distribute on the powder puff **2** evenly. Besides, it also cannot be spread on the face evenly and might make the face artificially white-skinned. It might fold the powder puff **2** and knead it. The powder can disperse in the powder puff **2** by this procedure and it's also has excellent efficiency on makeup by this procedure. But such procedure, which to fold the powder puff **2** and knead it, needs much time. It is inconvenient to use this procedure when in a rush time.

[0006] Conventionally, the user presses the powder puff **2** pressing on the powder case **3** that has a sieve **4**. There has a space between the powder case **3** and the sieve **4**. If there hasn't enough powder, the powder puff **2** always cannot obtain the powder by pressing on the powder case **3**. Because of this, the user always needs to slant the powder case **3** or to knock the powder case **3** lightly. Some people pour the powder from the powder case **3** on the paper and then pressing the powder puff **2** on the powder that on the paper. But such conditions always make the powder scattering everywhere. Sometime people pour too much powder or pour the powder on the table or on the ground. It is not only inconvenient but also wasting. Besides, the powder case **3** is a little larger and isn't suitable to carry. With above arrangements, it is inconvenient to carry outside.

[0007] Because the prior powder puff has some faults, such as spreading unequally, using and carrying inconveniently and etc. It is therefore tried by the inventor to develop a powder puff, which has a powder bag and a foamed plastic inside the surface cloth. The powder can be released outside the surface cloth from the powder bag. With the present invention, the users can spread the powder on

their face evenly without obtaining powder from the powder case. It is more convenient in using this powder puff, which has a powder bag inside.

SUMMARY OF THE INVENTION

[0008] A primary object of the present invention is to provide a powder puff, which has a powder bag inside the powder puff. The user only pats the powder puff lightly; the powder can be spread to the objective place evenly without obtaining the powder from the powder case. It is more convenient and it can decrease the waste of powder. It omits the device of powder case and can be more convenient to carry it outside.

[0009] To achieve the above objects, the powder puff of the present invention mainly includes a powder bag, which has powder inside and fine apertures on the surface, a foamed plastic, which can form the shape of powder puff, and a surface cloth, which wrap the powder bag and the foamed plastic and can be sewed to form a shape.

BRIEF DESCRIPTION OF THE DRAWINGS

[0010] The structure and technical means adopted by the present invention achieve the above and the objects can be best understood by referring to the following detailed description of the preferred embodiments and the accompanying drawings, wherein

[0011] **FIG. 1** is the prior powder puff;

[0012] **FIG. 2** is the exploded view of the present invention;

[0013] **FIG. 3** is the assembled view of the present invention;

DETAILED DESCRIPTION OF THE PREFERRED EMBODIMENTS

[0014] Please refer to **FIGS. 2**; it is the exploded view of the present invention. As shown, a powder puff of the present invention includes a surface cloth **8**, a foamed plastic **7** and a powder bag **5**. The powder bag **5** has powder inside and fine apertures on the surface. The powder was released from the powder bag **5** into the powder puff by the fine apertures. The foamed plastic **7** can form the shape of powder puff. Because the powder bag **5** is very supple and cannot form a shape easily, it needs a foamed plastic **7** to form a shape of the powder puff. Besides, the foamed plastic **7** can increase the thickness and the soft of the powder puff, and the foamed plastic **7** also can make the powder puff more comfortable. There isn't a fixed shape of the foamed plastic **7** (such as a circular form or a quadrangle) and the foamed plastic **7** doesn't has a fixed position inside the powder puff. There have many fine apertures and fine fur dispersing on surface cloth **8**. The fine apertures can let the powder outside of the powder puff and the fine fur can make the user more comfortable. The surface cloth **8** wraps the powder bag **5** and the foamed plastic **7** and then sewed to form a powder puff. It can put an adornment on the stitch. The adornment can make the powder puff more beautiful and the user can take the powder puff by this adornment.

[0015] Please refer to **FIG. 3**; it is the assembled view of the present invention. As shown, a powder puff of the present invention is a surface cloth **8**, which includes a

foamed plastic **7** and a powder bag **5**. There has a bowknot **9** putting on the stitch such as an adornment. The user can take the powder puff by this bowknot **9** and then pat lightly on the objective place. The pressure of patting can make the powder release from the powder bag **5** by the fine apertures. Because the powder bag **5** inside the powder puff, the powder puff doesn't need to obtain the powder from the powder case. Because the present invention lacks a procedure that need to obtain the powder from the powder case, the powder can be spread on the powder puff evenly. Because the present invention lacks a procedure that need to obtain the powder from the powder case, the powder puff doesn't need a procedure that to fold the powder puff and knead it. Besides, the powder puff of the present invention is a powder bag **5** inside the surface cloth **8**, so the user can only carry the present invention to outside. (The user can use a small bag to pack the present invention.) It is not only more convenient in using but also in carrying. It doesn't need to carry a powder case to outside, which is bigger and needs more space.

[0016] With the above arrangements, the present invention has following advantages.

[0017] 1. Because the powder bag **5** is inside the surface cloth **8** to form the powder puff of the present invention, the present invention doesn't need to obtain powder from other where. There doesn't need to pour the powder on the paper from the powder case, so it can prevent the waste of powder. It is more convenient in using and it also can save the time for makeup.

[0018] 2. The prior powder puff needs to fold the powder puff and knead it; this procedure can make the powder disperse evenly in the powder puff. The powder bag **5** is

inside the surface cloth **8** to form the powder puff of the present invention; so the powder, which released from the powder bag, has already dispersed evenly in the powder puff. When patting the powder puff of the present invention lightly, the enough powder release evenly from the surface cloth **8** of the powder puff. Makeup only uses one procedure, so the present invention can save the time for makeup.

[0019] 3. Because the powder bag **5** is inside the powder puff of the present invention, the user can carry the present invention to outside instead of the prior powder puff and the powder case. The user only uses a small bag to pack the present invention. The powder case is larger than the powder puff of the present invention. The present invention can save the space and has more convenience in carrying.

What is claimed is:

1. A powder puff comprising a powder bag, which has powder inside and fine apertures on the surface, a foamed plastic, which put in the one side of the powder bag and can form the shape of powder puff, and a surface cloth, which wrap the powder bag and the foamed plastic and be sewed in the one side near the foamed plastic to form a shape.

2. The powder puff as claimed in claim 1, wherein said foamed plastic is a circular form.

3. The powder puff as claimed in claim 1, wherein said foamed plastic is a quadrangle.

4. The powder puff as claimed in claim 1, wherein there is an adornment that putting on the stitch of said surface cloth.

5. The powder puff as claimed in claim 4, wherein said adornment is a bowknot.

* * * * *