



US00D795685S

(12) **United States Design Patent**
Rodenhouse et al.

(10) **Patent No.:** **US D795,685 S**

(45) **Date of Patent:** **** Aug. 29, 2017**

- (54) **WASHER**
- (71) Applicant: **Rodenhouse, Inc.**, Grand Rapids, MI (US)
- (72) Inventors: **Robert H. Rodenhouse**, Grand Rapids, MI (US); **Jason R. Wigboldy**, Grand Rapids, MI (US)
- (73) Assignee: **Rodenhouse, Inc.**, Grand Rapids, MI (US)

5,423,858 A	6/1995	Bolanos et al.	
5,517,883 A	5/1996	Goldi et al.	
5,541,377 A	7/1996	Stuhlmacher	
5,833,422 A	11/1998	Haga et al.	
D410,869 S	6/1999	Singer	
D414,406 S *	9/1999	Meyer	D8/399
6,039,525 A	3/2000	Johnson	
6,231,063 B1	5/2001	Chi	

(Continued)

(**) Term: **15 Years**

(21) Appl. No.: **29/544,536**

(22) Filed: **Nov. 4, 2015**

(51) **LOC (10) Cl.** **08-08**

(52) **U.S. Cl.**
USPC **D8/399**

(58) **Field of Classification Search**
 USPC D8/399, 382, 349, 397, 394
 CPC F16B 31/028; F16B 39/28; F16B 41/005;
 F16B 39/34; F16B 21/20; B65D 39/084;
 B60B 27/001; B25B 13/485
 See application file for complete search history.

(56) **References Cited**

U.S. PATENT DOCUMENTS

D32,360 S *	3/1900	Pierce	D8/399
D32,793 S	6/1900	Fauber	
888,982 A *	5/1908	Ette	F16B 5/0233 411/546
3,069,919 A	12/1962	Schultz	
3,362,737 A *	1/1968	Cobb	F16B 5/02 403/373
4,102,239 A	7/1978	Dallas	
4,292,876 A	10/1981	De Graan	
4,793,757 A	12/1988	Peterson	
5,079,055 A	1/1992	Doyle	
D327,111 S *	6/1992	Hemming	D22/134
5,419,666 A	5/1995	Best	

OTHER PUBLICATIONS

Brochure disclosing 2" diameter Plasti-Grip® PBLP2 washer distributed by Rodenhouse Inc. more than one year prior to Sep. 6, 2012.

(Continued)

Primary Examiner — Cynthia Underwood
(74) *Attorney, Agent, or Firm* — Gardner, Linn, Burkhart & Flory, LLP

(57) **CLAIM**

The ornamental design for the washer, as shown and described.

DESCRIPTION

FIG. 1 is a side perspective view of the washer;
 FIG. 2 is a top perspective view of the washer of FIG. 1;
 FIG. 3 is a bottom perspective view of the washer of FIG. 1;
 FIG. 4 is a top plan view of the washer of FIG. 1;
 FIG. 5 is a side elevation view of the washer of FIG. 1;
 FIG. 6 is a side elevation view of the washer of FIG. 1 rotated 90 degrees relative to the view shown in FIG. 5; and,
 FIG. 7 is a bottom plan view of the washer of FIG. 1.
 The broken lines depict environmental subject matter and form no part of the claim. The boundary lines that separate the lines emanating out from the inner portion of the claim represent a boundary of the claim.

1 Claim, 7 Drawing Sheets

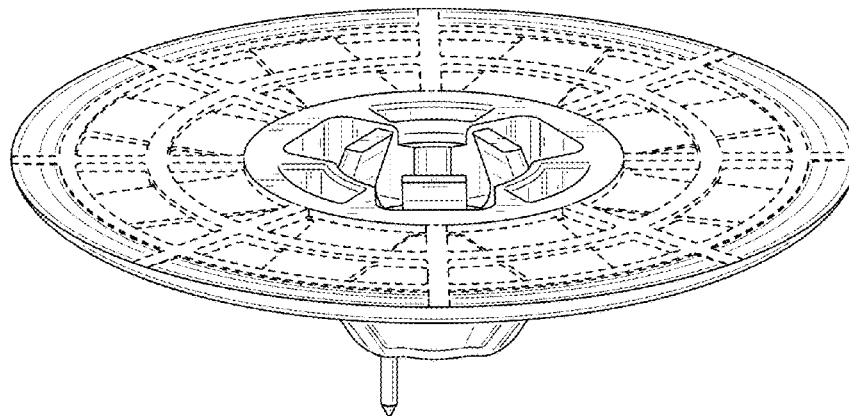

(56)

References Cited

U.S. PATENT DOCUMENTS

D482,270 S	11/2003	Derilo	
6,705,813 B2 *	3/2004	Schwab	F16B 21/20 411/156
D517,404 S	3/2006	Schluter	
D528,407 S *	9/2006	Schwab	D8/399
D549,091 S	8/2007	McIntyre et al.	
D576,480 S	9/2008	Vakiener et al.	
D596,934 S	7/2009	Vakiener et al.	
D634,248 S	3/2011	Chen	
7,896,380 B2	3/2011	Tange	
D644,921 S	9/2011	Hsu et al.	
D645,337 S	9/2011	Hsu et al.	
D660,691 S	5/2012	Yamazaki	
D663,243 S	7/2012	Li et al.	
8,413,740 B2	4/2013	Rodenhouse	
D682,666 S	5/2013	Wigboldy	
D692,747 S *	11/2013	Schwab	D8/399
D696,930 S	1/2014	Rodenhouse et al.	
D696,931 S	1/2014	Rodenhouse et al.	
D696,932 S	1/2014	Rodenhouse et al.	
D703,034 S *	4/2014	Stewart	D8/399
D710,191 S	8/2014	Yamazaki et al.	
9,206,807 B2 *	12/2015	Li	F16F 1/324
D748,973 S *	2/2016	Rodenhouse	D8/399
D749,941 S *	2/2016	Rodenhouse	D8/399
D755,622 S *	5/2016	Rodenhouse	D8/399
2004/0060723 A1	4/2004	Pallapothu	
2004/0084099 A1	5/2004	Miura	
2006/0171794 A1	8/2006	Ordonio, Jr. et al.	
2008/0310932 A1	12/2008	McIntyre et al.	

OTHER PUBLICATIONS

Brochure disclosing 1 3/4" diameter Plasti-Grip® CBW washer distributed by Rodenhouse Inc. more than one year prior to Sep. 6, 2012.

Brochure disclosing 1 1/4" diameter Grip-Plate® Tab washer distributed by Rodenhouse Inc. more than one year prior to Sep. 6, 2012.

Brochure disclosing 1 1/4" diameter Grip-Plate® Plastic washer distributed by Rodenhouse Inc. more than one year prior to Sep. 6, 2012.

Brochure disclosing 2" diameter Plasti-Grip® CBW2 washer distributed by Rodenhouse Inc. more than one year prior to Sep. 6, 2012.

Brochure disclosing 1 3/4" diameter Plasti-Grip® III washer distributed by Rodenhouse Inc. more than one year prior to Sep. 6, 2012.

Brochure disclosing Plasti-Grip® PMF Plastic Masonry Fastener distributed by Rodenhouse Inc. more than one year prior to Sep. 6, 2012.

Brochure disclosing 3" diameter Grip-Lok® "Hurricane" washer distributed by Rodenhouse Inc. more than one year prior to Sep. 6, 2012.

Specification and Drawings of commonly owned and co-pending U.S. Appl. No. 29/503,882, filed Sep. 30, 2014.

Specification and Drawings of commonly owned and co-pending U.S. Appl. No. 29/521,024, filed Mar. 19, 2015.

Specification and Drawings of commonly owned and co-pending U.S. Appl. No. 29/514,877, filed Jan. 16, 2015.

* cited by examiner

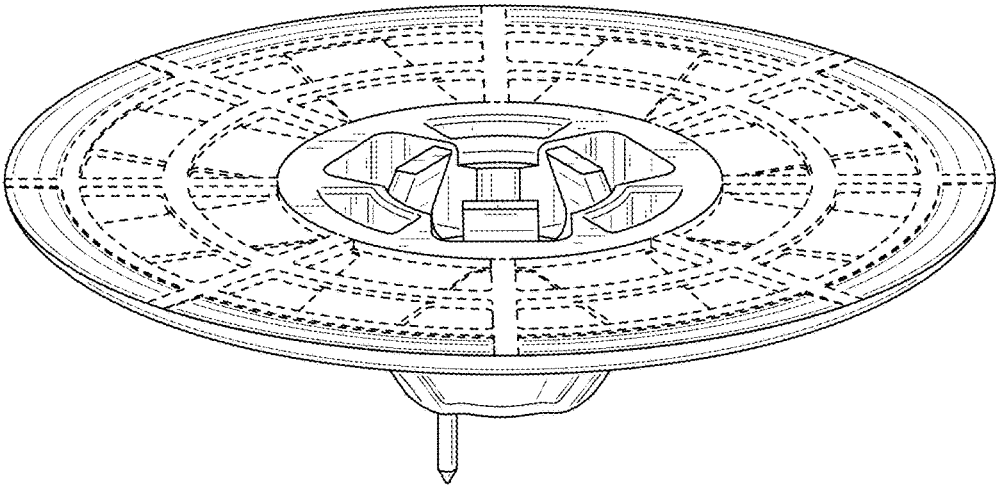

FIG. 1

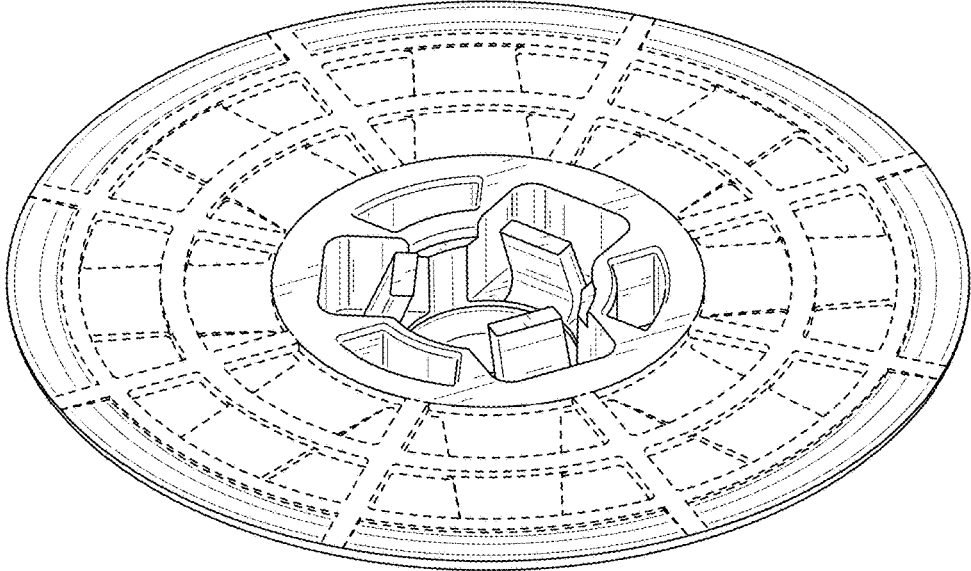

FIG. 2

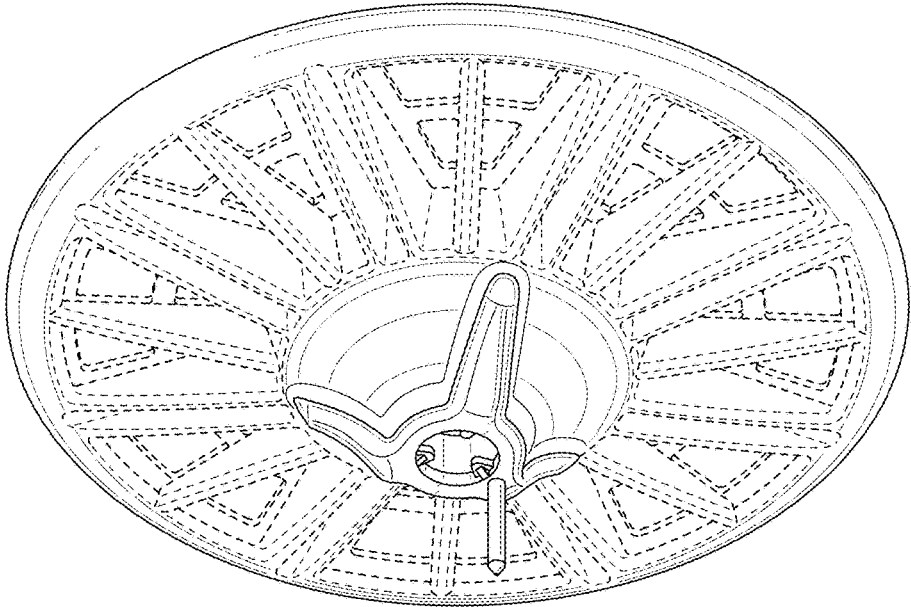

FIG. 3

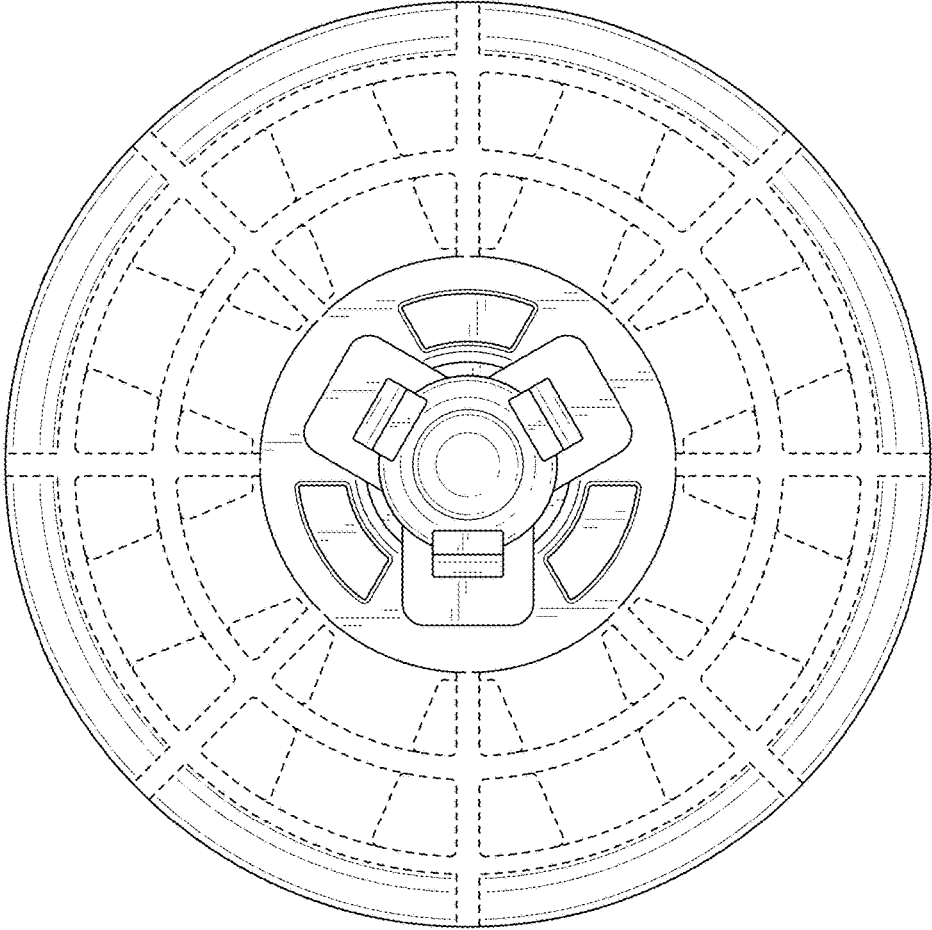

FIG. 4

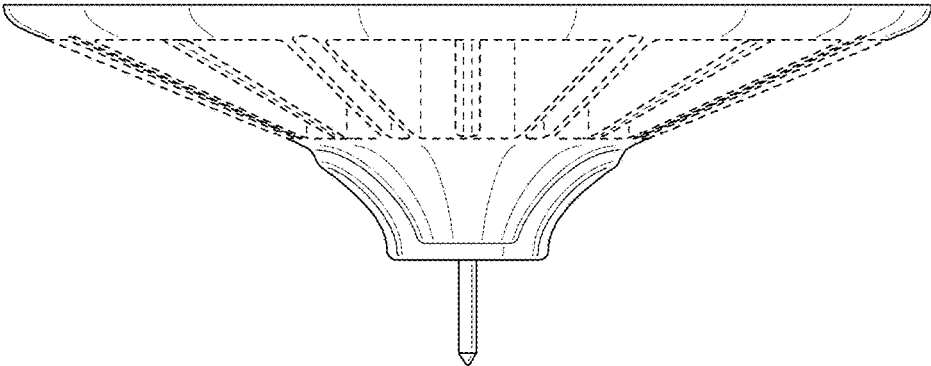

FIG. 5

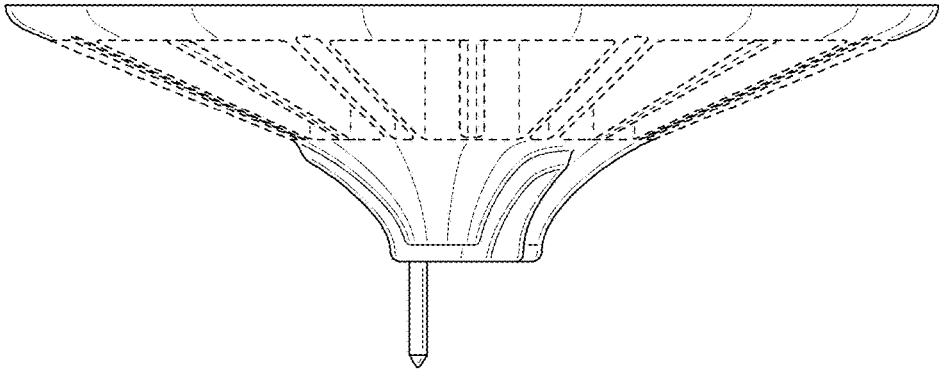

FIG. 6

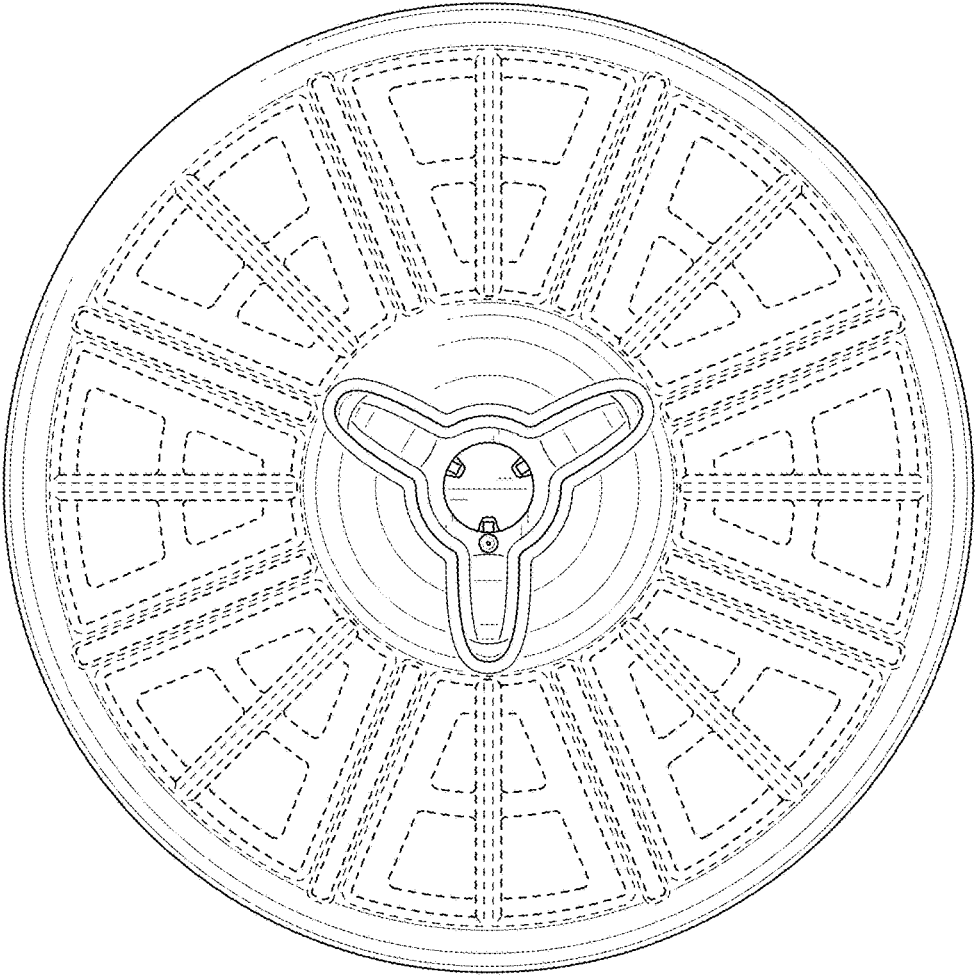

FIG. 7