

No. 610,135.

Patented Aug. 30, 1898.

W. H. GREEN.
SASH LIFT.

(Application filed Mar. 15, 1898.)

(No Model.)

Fig. 1

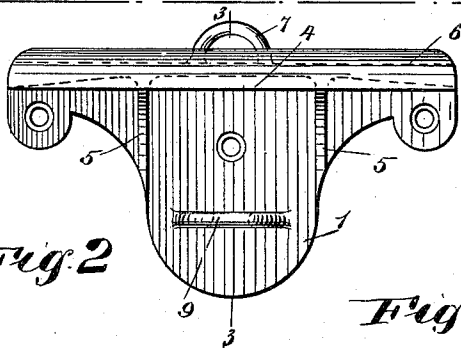
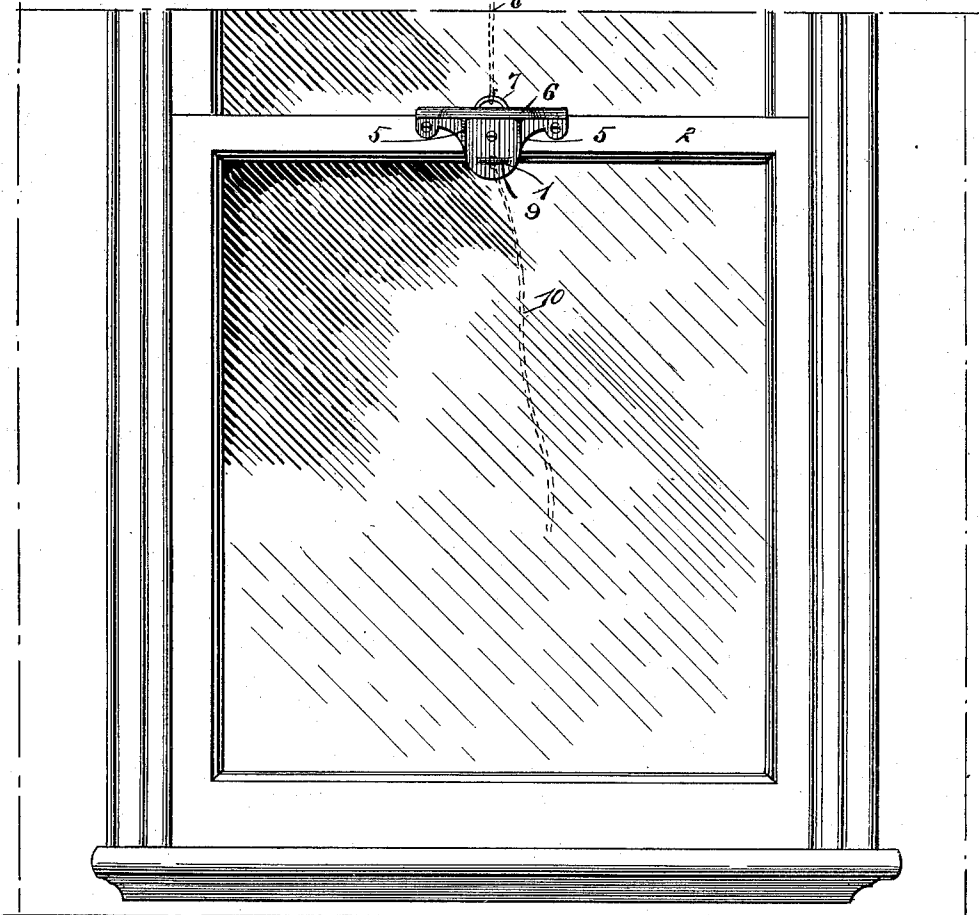

Fig. 2

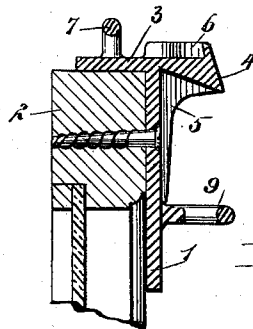
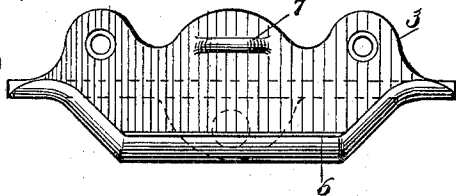

Fig. 3

Fig. 4



WITNESSES:

John B. ...
C. A. ...

INVENTOR

W. H. Green

BY

Murray

ATTORNEYS.

UNITED STATES PATENT OFFICE.

WILLIAM HENRY GREEN, OF ELIZABETH, NEW JERSEY.

SASH-LIFT.

SPECIFICATION forming part of Letters Patent No. 610,135, dated August 30, 1898.

Application filed March 15, 1898. Serial No. 673,952. (No model.)

To all whom it may concern:

Be it known that I, WILLIAM HENRY GREEN, of Elizabeth, in the county of Union and State of New Jersey, have invented a new and Improved Window-Sash Attachment, of which the following is a full, clear, and exact description.

This invention relates to devices designed to be attached to a window-sash to facilitate raising and lowering of the same, and the object is to provide a simple and comparatively inexpensive device that may be readily attached to the sash and serve to prevent the accidental breaking of the glass by the slipping of a hook or other similar instrument that may be used for operating the sash.

I will describe a sash attachment embodying my invention and then point out the novel features in the appended claims.

Reference is to be had to the accompanying drawings, forming a part of this specification, in which similar characters of reference indicate corresponding parts in all the views.

Figure 1 is a front elevation of a sash attachment embodying my invention and showing the same as attached to a sash. Fig. 2 is a front elevation of the attachment drawn on an enlarged scale. Fig. 3 is a section on the line 3 3 of Fig. 2, and Fig. 4 is a top plan view.

The attachment comprises a plate or shield 1, designed to engage against and be secured to the inner surface of the upper rail 2 of the sash. At the top of the plate or shield 1 is an outwardly-extended flange 3, designed to engage against the upper surface of the sash-rail, and extended inward from the upper end or edge of the plate 1 is a ledge 4, the under side of which is inclined downward and inward. This ledge is designed to be engaged by a rod, hook, or other device for the purpose of raising the window-sash. The incline of the ledge will prevent the raising instrument from sliding outward, and to prevent its sliding laterally I have here shown inwardly-extending brackets 5, integral with the plate 1 and also with the ledge 4. These brackets, of course, are arranged one on each side of the center of the plate 1.

Extended around the upper inner edge of the ledge 4 is an upwardly-extended flange 6, designed to be engaged by a hook or similar

instrument when drawing the sash down. On the flange 3 and outward of the flange 6 is an upwardly-extended stop 7. This stop 7 is made in the form of a staple or loop and may serve two purposes—that is, it will serve to prevent a hook or similar instrument from slipping outward on the top of the device and striking against the glass of the upper sash, and it will also serve as a means for attaching a cord 8, which may be run up over a suitable pulley and employed for raising the sash when it is not desired to use a hook or other similar device.

Extended outward from the plate 1 is a stop 9, here shown in the form of a staple or loop and designed to serve two purposes—that is, it will prevent a hook or rod from slipping downward over the lower edge of the plate 1 and striking against the glass of the lower sash, and it will also serve as a means for attaching a cord 10 for drawing the sash down. It will be noted that the plate 1 extends a short distance below the lower edge of the top rail. Therefore it has a considerable area against which a hook or similar device may engage.

A device embodying my invention is particularly adapted for use on window-sashes in factories, shops, and the like, where obstacles, such as work-benches, are usually placed near the window, thereby rendering access to a sash somewhat difficult, and to overcome this difficulty to some extent workmen usually employ a rod, stick, or anything that may come to hand for the purpose of raising the sash, and therefore there is considerable danger of breaking the glass.

The attachment may be made by any suitable means—such, for instance, as by casting or stamping—and obviously it may be made as ornamental as desired.

While I have shown the device as attached to the lower sash, it is clear that the principle involved also adapts it for an upper sash.

Having thus described my invention, I claim as new and desire to secure by Letters Patent—

1. An attachment for a window, comprising a plate or shield adapted to be attached to the top rail of a sash, an inwardly-extended ledge at the upper edge of said plate or shield, and brackets extended inward from

the plate or shield below said ledge, substantially as described.

2. An attachment for a window-sash, comprising a plate or shield adapted to be secured
5 to the inner side of the top rail of a sash, an inwardly-extended ledge at the upper edge of said plate or shield, and an upwardly-extended flange on the inner upper edge of said ledge, substantially as specified.

10 3. An attachment for a window-sash, comprising a plate or shield adapted to be attached to the inner surface of the upper rail of the window-sash, a ledge extended inward from the upper edge of said plate or shield,
15 and a stop extended inward from said plate or shield below the ledge, substantially as specified.

4. An attachment for a window-sash, comprising a plate or shield adapted to be attached
20 to the inner side of the top rail of a sash, and having a flange for engaging over the upper surface of said top rail, a ledge extended inward from the upper edge of the plate or shield, a flange extended upward

from the inner upper edge of said ledge, and
25 a stop on the flange which extends over the upper surface of the rail, substantially as specified.

5. An attachment for a window-sash, comprising a plate or shield adapted to be secured
30 to the inner side of the top rail of a sash, and having an outwardly-extended flange at its top to engage upon the top of the upper rail, a loop-shaped stop extended upward from said flange, a ledge extended inward from the upper
35 edge of the plate or shield, and having its under side inclined downward and inward, an upwardly-extended flange on the upper inner edge of said ledge, a loop-shaped stop
40 extended inward from the plate below said ledge, and brackets extended inward from said plate at the sides of its center, substantially as specified.

WILLIAM HENRY GREEN.

Witnesses:

CHARLES L. GILLIES,
WALTER N. COLVELL.