

# United States Patent

Seidler

[15] 3,645,281

[45] Feb. 29, 1972

[54] **PARTS HOLDER**

[72] Inventor: David Seidler, 69-10 108th St., Forest Hills, N.Y. 11375

[22] Filed: Apr. 3, 1970

[21] Appl. No.: 25,493

2,744,624 5/1956 Hoogstoel et al. ....206/DIG. 18  
3,333,593 8/1967 McGiven.....132/31 R

*Primary Examiner*—Louis G. Mancene  
*Assistant Examiner*—Gregory E. McNeill  
*Attorney*—Blum, Moscovitz, Friedman & Kaplan

**Related U.S. Application Data**

[63] Continuation-in-part of Ser. No. 689,101, Dec. 8, 1967, Pat. No. 3,516,423.

[52] U.S. Cl. ....132/88.7, 206/DIG. 18

[51] Int. Cl. ....A45d 40/26

[58] Field of Search.....132/88.7, 53, 5, 79, 32, 31.2, 132/45, 88.5, 79.1; 206/DIG. 18

[57] **ABSTRACT**

A parts holder which has a base or support element coated with a washable adhesive so that various parts can be adhered to the adhesive surface to store the parts, secure the parts during shipment or transfer between location, or to hold the parts so they may be worked on. The adhesive surface is renewable by being washable so that it may be continually reused, even if it becomes contaminated with foreign matter.

**References Cited**

**UNITED STATES PATENTS**

2,165,539 7/1939 Dahlgren .....206/DIG. 18

7 Claims, 5 Drawing Figures

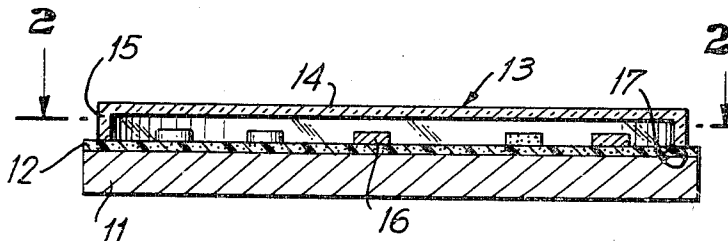

FIG. 1

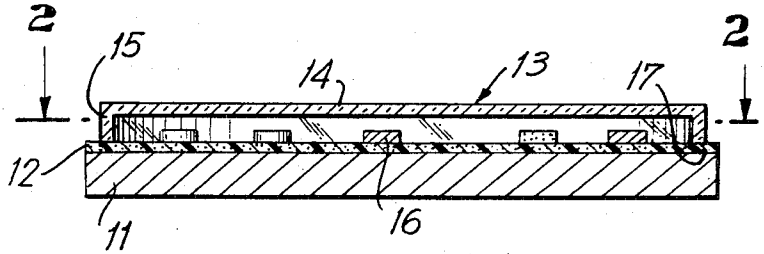

FIG. 2

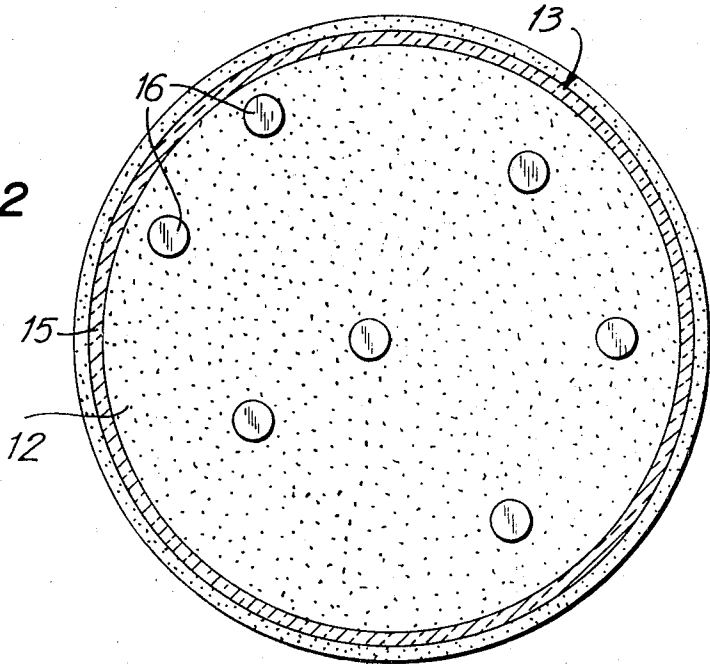
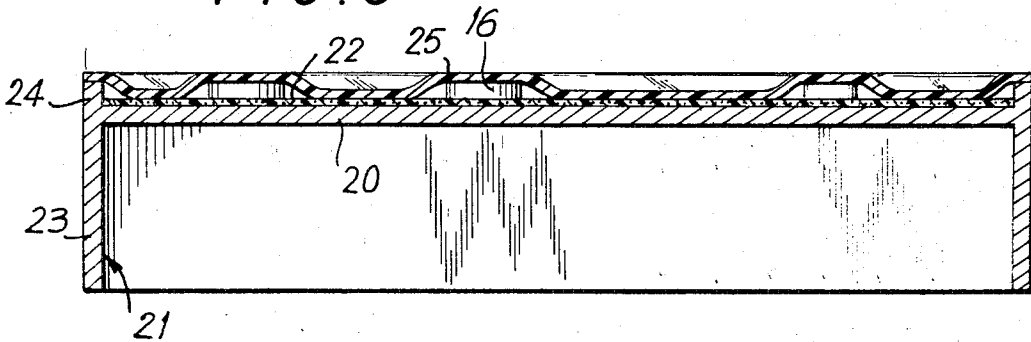

FIG. 3



INVENTOR  
DAVID SEIDLER

BY

Blum, Moscovitz, Friedman, Kaplan  
ATTORNEYS

FIG. 4

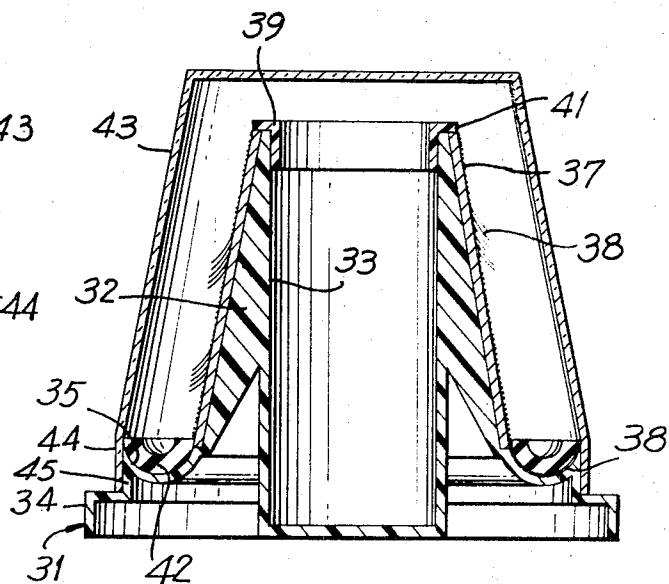
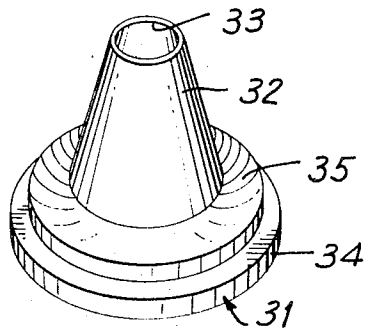
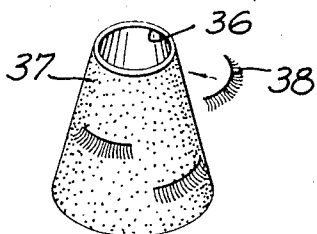
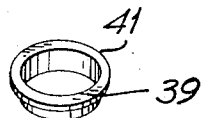
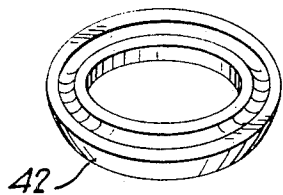
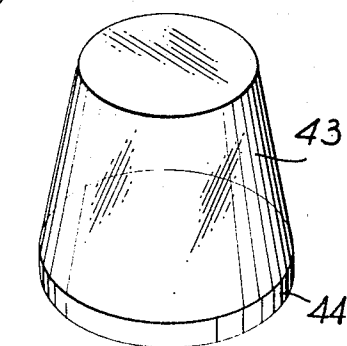

FIG. 5

INVENTOR,  
DAVID SEIDLER

BY

*Blum, Moscovitz, Friedman & Kaplan*  
ATTORNEYS

# 1

## PARTS HOLDER

### CROSS-REFERENCE TO RELATED APPLICATION

This application is a continuation in part of application Ser. No. 689,101, now U.S. Pat. No. 3,516,423 of Dec. 8, 1967.

### BACKGROUND OF THE INVENTION

This invention relates generally to a parts holder consisting essentially of a base or support member and an adhesive. While adhesives have been used in the prior art to have parts adhered thereto, such items generally have two substantial drawbacks. Firstly, the adhesive surfaces, through use, will become contaminated and lose their tackiness as a result of dirt and other foreign materials adhering thereto whereby, after a period of time, the surface can no longer function as an adhesive. Secondly, the adhesive quite often will adhere to the part when the part is removed therefrom, to leave foreign matter on the part and contaminate the part.

### SUMMARY OF THE INVENTION

Generally speaking, in accordance with the invention, a base or support member has a washable adhesive applied thereto, such adhesive providing a tacky surface for the support of various parts and being continually reusable over extended periods of time. Even if the surface of the adhesive should become contaminated, it can be returned to like-new condition by washing the adhesive. The adhesive, having superior qualities of integrity, will not be transferred to the parts when the parts that were temporarily secured to the adhesive surface are removed therefrom.

The usefulness of such a part holder is beyond question. Industry, and especially the electronics industry, is constantly devoting its development toward miniaturization. Microcircuits, memory cores and other elements have been reduced to such minute size that a serious problem of handling such parts has developed. It has become difficult to transport the parts, even from station to station along a production line, to hold the parts while they are being worked on, and to conveniently package the parts or seal them from adverse atmospheric conditions.

The instant invention has substantially broader applications in that said invention is useful for storing and supporting a wide variety of parts that are not otherwise easily handled and stored. For example, false eyelashes, which are commonly used as cosmetic items, are very light and flexible, are difficult to handle, can be easily blown away and can become entangled, one with another. By utilizing the instant invention, parts such as false eyelashes can easily be stored, handled, applied and otherwise manipulated without contamination of the false eyelashes.

Accordingly, it is an object of this invention to provide an improved parts holder capable of receiving, supporting and releasing a wide variety of parts placed thereon.

Another object of the invention is to provide a parts holder which can have parts temporarily adhered thereto, without effecting a contamination of the parts after removal from the parts holder.

A further object of the invention is to provide an improved parts holder having an adhering surface whose adhesion can be readily renewed after contamination of same.

Still another object of the invention is to provide an improved parts holder having a washable adhesive surface.

Still other objects and advantages of the invention will in part be obvious and will in part be apparent from the specification.

The invention accordingly comprises the features of construction, combinations of elements, and arrangement of parts which will be exemplified in the constructions hereinafter set forth, and the scope of the invention will be indicated in the claims.

# 2

## BRIEF DESCRIPTION OF THE DRAWINGS

FIG. 1 is a sectional view of a parts holder constructed in accordance with a preferred embodiment of the instant invention;

FIG. 2 is a sectional view taken along line 2—2 of FIG. 1;

FIG. 3 is a sectional view of a parts holder constructed in accordance with another embodiment of the instant invention;

FIG. 4 is an exploded view of a parts holder for false eyelashes constructed in accordance with another embodiment of the instant invention; and

FIG. 5 is a sectional, elevational view of the parts holder of FIG. 4 in assembled condition.

## DESCRIPTION OF THE PREFERRED EMBODIMENT

Referring now to FIGS. 1 and 2, a parts holder formed of a support element 11 has on the top surface thereof a coating of adhesive 12. Adhesive 12 is washable and is preferably an acrylic base adhesive or a silicone base adhesive. Such adhesives will remain tacky to perform their adhesive function even after repeated washings and such adhesives will not contaminate the parts adhered thereto after said parts have been removed.

A cover 13 has a top 14 and a depending flange 15. Cover 14 is preferably transparent so that the parts on the holder may be viewed therethrough. A plurality of randomly spaced parts 16 are shown as being adhered to washable adhesive 12. The parts may be miniaturized electronic elements which will be adhered to the adhesive surface on contact therewith and which will remain on said surface despite jarring, vibration, etc. Depending flange 15 has a contacting edge 17 which makes contact with the surface of adhesive 12 to releasably secure cover 13 to support element 11 and protect parts 16 releasably mounted on the adhesive surface. By use of a transparent cover, the parts can be observed and the assemblage shown in FIGS. 1 and 2 can be transported and shipped while providing full protection of the parts.

With cover 13 removed, the parts holder, consisting of support element 11 and adhesive 12, can act as a worktable to perform form operations on the parts without permitting the parts to move, unless the operator so desires. Should the surface of adhesive 12 become contaminated from dirt or other foreign matter that may adhere thereto, especially when acting as a worktable, it is merely necessary to wash the surface of the adhesive for renewal of same.

Referring to FIG. 3, the parts holder shown therein is especially suitable for use as a worktable. Support element 21 may be rectangular in plan and has a support surface 20 to which is applied a washable adhesive 22 of the type heretofore described. The support element includes a depending flange 23 and an upstanding lip 24 for a purpose to be hereafter described. Parts 16 are received on the surface and the surface can function as a worktable in the manner heretofore described. In order to protect the parts during transfer or shipment, a flexible sheet 25 is laid over the adhesive and the parts thereon. Flexible sheet 25 is preferably formed of material such as polyethylene, Mylar, Saran and the like. The flexible sheet will conform itself generally to the surface of the worktable as shown in FIG. 3 and will intermittently contact the washable adhesive so as to seal around the parts 16. The flexible sheet is preferably larger than the adhesive area of the worktable so as to extend over lips 24 in order to provide a portion not adhered to the worktable which may be gripped for removal of the flexible sheet.

With parts holders of the type heretofore described, a substantial number of advantages derive therefrom. The parts holder has numerous applications such as packaging, storage, shipment and the like. The washable adhesive surface is reusable, even if contaminated, and the parts holder is shockproof in that the holding power of the acrylic base or silicone base adhesive prevents the parts from being dislodged, even by shock. Furthermore, the parts will be held on the holder in any position thereof and regardless of the position of the parts

holder. By utilizing a cover, such as cover 13 or flexible sheet 25, a seal about the individual parts or a group of parts may readily be effected to provide a moisture proof package. Such adhesive materials are inert in that they do not contaminate the parts and the surface of the adhesive is such that it will hold parts of substantially any shape, thereby making the parts holder especially suitable for use as a work table. Also, for very small parts, the parts can be easily packaged and stored to facilitate taking inventory and arranging shipment of parts.

Another application of the instant invention is shown in the embodiments of FIGS. 4 and 5, whereby a device made in accordance with the teachings of the instant invention is especially suitable for the storage of false eyelashes.

The false eyelash holder is provided with a base 31 having an upwardly extending portion 32 in the form of a truncated cone. Cone-shaped portion 32 is preferably formed with a central bore 33 which may serve as storage for cosmetic implements such as tweezers, adhesive, etc. Base 31 has a peripheral flange 34 and an arcuate seat 35 intermediate flange 34 and cone-shaped portion 32 for a use to be hereafter described.

An envelope 36 in the form of a thin-walled, hollow, truncated cone, has washable adhesive 37 applied to the surface thereof in order to removably receive false eyelashes 38. A retaining ring 39 is frictionally received in bore 33 with a flange 41 projecting over the top edge of cone-shaped portion 32 and envelope 36 to hold the envelope on the cone-shaped portion.

With the structure thus far described, a woman can store several pair of false eyelashes around the periphery of the envelope by temporarily adhering them to the adhesive. The curvature, as a result of the cone-shaped envelope, assures that the eyelashes are held in a curved condition so that the curvature of the connecting part of the eyelash is not disturbed since false eyelashes are generally formed to have a curvature generally corresponding with the curvature of the human eyelid.

If, after extensive use of the adhesive surface for storage, the surface becomes contaminated by eyelash glue, mascara or other foreign matter, retaining ring 39 can be removed to permit removal of envelope 36 whereby the adhesive on the envelope can be renewed by washing same.

It is also desirable for false eyelashes to retain the upward sweep or curvature of the lash and the curvature or sweep is often removed when the false eyelashes are cleaned. In order to hold the lashes in an upward curve, arcuate seat 35 is provided around the periphery of base 31. By mounting a false eyelash on adhesive 37 proximate the bottom edge of envelope 36, the lashes become located in arcuate seat 35 as shown in the lower right-hand corner of FIG. 5. A retaining ring 42 having a curved lower surface mating with arcuate seat 35 is placed so as to seat in the arcuate seat thereby forming the lashes in the seat into a curvature corresponding to the curvature of the seat and the cooperating retaining ring, so that a curved set is imparted to the lashes.

A transparent or translucent cover 43 is adapted to overfit base 31 as best seen in FIG. 5 to protect the false eyelashes and the adhesive surface from environmental factors for storage, shipment, travel, etc. The lower edge 44 of cover 43 preferably rests against flange 34 in frictional engagement with a wall 45 extending between flange 34 and arcuate seat 35. The main or central portion of cover 43 is also cone-shaped and is adapted to engage with an edge of retaining ring 39 to hold the retaining ring in arcuate seat 35 when cover 43 is in place.

Several embodiments of the instant invention have been described hereinabove. A wide variety of parts can be mounted, stored or otherwise worked on by utilization of a parts holder constructed pursuant to the teachings of the in-

stant invention. By utilization of a washable adhesive, such as a silicone base adhesive or an acrylic base adhesive, small and light parts can be adhered to the holder and readily removed therefrom as desired. Such adhesives do not contaminate the parts and any contamination of the adhesive surface by foreign matter can be readily eliminated by a washing of the adhesive surface to renew the surface and render it continually reusable.

By utilization of the concepts of the invention, a wide variety of parts holder may be constructed having significant advantages. For example, parts holders of the type shown in FIGS. 1 through 3 can be used to support, store, seal, have work done, ship or otherwise handle small and delicate parts such as electronic components. The device shown in FIGS. 4 and 5 illustrates the advantages that flow from utilization of the teachings of the instant invention by way of simplicity of design and construction of a parts holder for false eyelashes.

It will thus be seen that the objects set forth above, among those made apparent from the preceding description, are efficiently attained and, since certain changes may be made in the above constructions without departing from the spirit and scope of the invention, it is intended that all matter contained in the above description or shown in the accompanying drawings shall be interpreted as illustrative and not in a limiting sense.

It is also to be understood that the following claims are intended to cover all of the generic and specific features of the invention herein described, and all statements of the scope of the invention which, as a matter of language, might be said to fall therebetween.

I claim:

1. A parts holder comprising a flangelike base member and an upstanding portion projecting upwardly from said base member, said upstanding portion having the general configuration of a truncated cone defining a surface adapted for receiving parts thereon, and a washable adhesive applied to said surface for receiving and removably supporting said parts without contamination of same, said adhesive being washable for renewal of same.

2. A parts holder as claimed in claim 1 wherein said upstanding portion includes an envelope removably mounted thereon, said washable adhesive being applied to said envelope.

3. A parts holder as claimed in claim 2 and including a bore extending into said cone-shaped, upstanding portion along the longitudinal axis thereof, said bore communicating with the interior of said upstanding portion through the small end of said truncated cone.

4. A parts holder as claimed in claim 3 and further including a retaining ring releasably mounted in said bore, said retaining ring including a portion extending outwardly beyond said cone-shaped, upstanding portion, whereby to releasably retain said envelope.

5. A parts holder as claimed in claim 2 and including an arcuate seat on said flangelike base, contiguous with said upstanding portion.

6. A parts holder as claimed in claim 5 and including a ring member adapted for engagement with said flangelike base and having a surface substantially conforming to the shape of said arcuate seat.

7. A parts holder as claimed in claim 6 and further including a cover member having a peripheral edge in engagement with said flangelike base for releasably retaining said cover member in a position enveloping said upstanding portions and a substantial amount of said flangelike base, said cover member including a portion adapted for engagement with a portion of said ring member to retain said ring member in said arcuate seat when said cover member is mounted on said flangelike base.

\* \* \* \* \*