

(19) World Intellectual Property Organization
International Bureau



(43) International Publication Date
8 January 2009 (08.01.2009)

PCT

(10) International Publication Number
WO 2009/006343 A1

- (51) International Patent Classification:
F24H 7/02 (2006.01)
- (21) International Application Number:
PCT/US2008/068663
- (22) International Filing Date: 27 June 2008 (27.06.2008)
- (25) Filing Language: English
- (26) Publication Language: English
- (30) Priority Data:
11/770,152 28 June 2007 (28.06.2007) US
- (71) Applicant (for all designated States except US): **CORVID INC.** [US/US]; 1524 Belford Court, Evergreen, Colorado 80439 (US).
- (72) Inventors; and
- (75) Inventors/Applicants (for US only): **KROLL, Steven, C.** [US/US]; 4162 Beaver Brook Canyon Road, Evergreen, Colorado 80439 (US). **ANDREWS, John, W.** [US/US]; 381 Forget Me Not Lane, Idaho Springs, Colorado 80452 (US).
- (74) Agent: **DOCKERY, David F.**; **MARSH FISCHMANN & BREYFOGLE LLP**, 8055 East Tufts Avenue, Suite 450, Denver, Colorado 80237 (US).

- (81) Designated States (unless otherwise indicated, for every kind of national protection available): AE, AG, AL, AM, AO, AT, AU, AZ, BA, BB, BG, BH, BR, BW, BY, BZ, CA, CH, CN, CO, CR, CU, CZ, DE, DK, DM, DO, DZ, EC, EE, EG, ES, FI, GB, GD, GE, GH, GM, GT, HN, HR, HU, ID, IL, IN, IS, JP, KE, KG, KM, KN, KP, KR, KZ, LA, LC, LK, LR, LS, LT, LU, LY, MA, MD, ME, MG, MK, MN, MW, MX, MY, MZ, NA, NG, NI, NO, NZ, OM, PG, PH, PL, PT, RO, RS, RU, SC, SD, SE, SG, SK, SL, SM, SV, SY, TJ, TM, TN, TR, TT, TZ, UA, UG, US, UZ, VC, VN, ZA, ZM, ZW.
- (84) Designated States (unless otherwise indicated, for every kind of regional protection available): ARIPO (BW, GH, GM, KE, LS, MW, MZ, NA, SD, SL, SZ, TZ, UG, ZM, ZW), Eurasian (AM, AZ, BY, KG, KZ, MD, RU, TJ, TM), European (AT, BE, BG, CH, CY, CZ, DE, DK, EE, ES, FI, FR, GB, GR, HR, HU, IE, IS, IT, LT, LU, LV, MC, MT, NL, NO, PL, PT, RO, SE, SI, SK, TR), OAPI (BF, BJ, CF, CG, CI, CM, GA, GN, GQ, GW, ML, MR, NE, SN, TD, TG).

Published:
— with international search report

(54) Title: STRUCTURAL WALL PANELS AND METHODS AND SYSTEMS FOR CONTROLLING INTERIOR CLIMATES

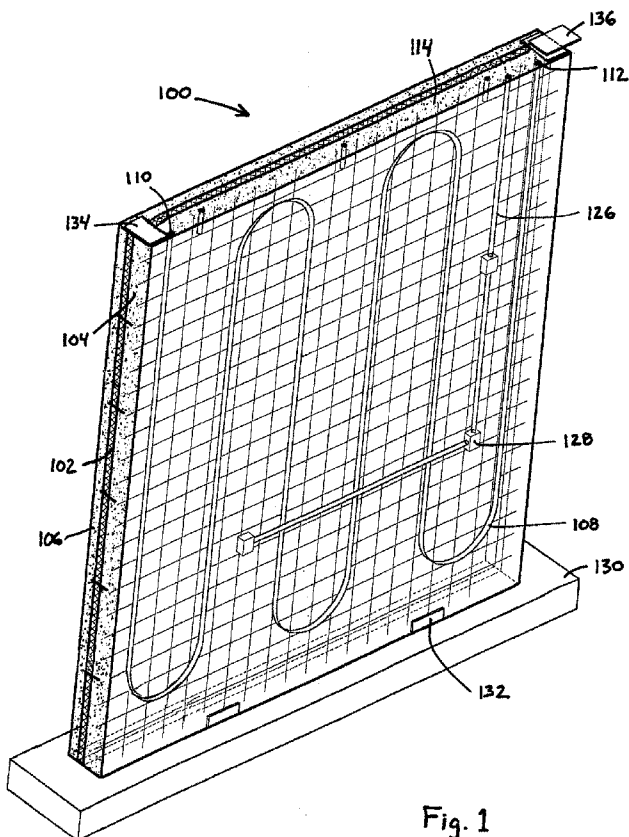

Fig. 1

(57) Abstract: Structural wall panels and methods and systems for controlling the interior temperature of a building are provided. The structural wall panels advantageously include a fluid conduit disposed within an interior concrete layer of the structural wall panel where the conduit is adapted to convey a thermal transfer fluid through the interior concrete layer. A thermal insulation layer is provided between the first concrete layer and a second concrete layer, which can be disposed on an exterior surface of the wall. The thermal transfer fluid can be heated and/or cooled to regulate the temperature of the interior concrete layer and thereby control the temperature of the interior of the building. The first concrete layer can have a high thermal mass to increase the efficiency of the system.

WO 2009/006343 A1

STRUCTURAL WALL PANELS AND METHODS AND SYSTEMS FOR CONTROLLING INTERIOR CLIMATES

BACKGROUND OF THE INVENTION

5 1. **Field of the Invention**

The present invention relates to structural wall panels useful for the fabrication of building structures, and to systems and methods for controlling the climate within building structures. More particularly, the present invention relates to insulated concrete structural wall panels that are temperature-regulated by passing a thermal transfer fluid such as water through the panels. The present invention also relates to methods for regulating the interior temperature of a building structure using temperature-regulated interior walls.

2. **Description of Related Art**

One of the most significant uses of energy is directed to maintaining a comfortable climate within residential or commercial buildings. Rising energy costs have necessitated the development of low-energy solutions for climate control within the interior of a building. Further, the environmental hazards associated with modern energy production, such as the generation of greenhouse gases, has led to the desire to fabricate buildings having a reduced carbon footprint, i.e., one that consumes less energy for construction and less energy for day-to-day living.

It has been suggested to provide heating and cooling by use of a thermal transfer fluid, such as air or water, within the floors and walls of a building structure.

For example, U.S. Patent No. 4,000,850 by Diggs discloses a solar heated and cooled modular building that includes insulated, prefabricated wall and roof panels supported on tubular wall columns and roof beams. Fluid circulating means is connected with the tubular wall columns and roof beams to circulate fluid therethrough at a desired temperature to maintain a desired temperature in the building. For example, solar panels can be supported on the roof of the building and a heat pump can be connected to the solar panels to circulate a heat exchange fluid through the solar panels to absorb heat.

U.S. Patent No. 4,442,826 by Pleasants discloses a passive solar device comprising a pre-cast construction panel that is useful for buildings. The panel includes an internal, concealed containment element for the storage and circulation of a thermally efficient fluid, such as water. The fluid-filled
5 containment element serves as a core around which cementitious material, such as concrete, is placed. To facilitate thermal fluid flow, the device includes top and bottom nipples to facilitate connection of the device with other system elements.

U.S. Patent No. 4,295,415 by Schneider, Jr. discloses an environmentally heated and cooled insulated concrete building that includes a continuous layer of
10 foamed insulation within all exterior walls. The building is constructed of reinforced concrete having an outer and inner layer connected together along a lower edge, and the walls are assembled at the job site and filled with foam insulation. The outer concrete wall is provided with air ducts. Damper and blower controls provide solar heating in cold weather by circulating air that has
15 been warmed in the exterior ducts to the interior of the building and air circulation cooling in hot weather.

U.S. Patent No. 4,164,933 by Alosi discloses a passive solar collector comprising pre-cast concrete panels having serpentine-like passageways disposed near a surface of the panel. The panels are placed to collect radiant
20 solar energy, such as by placement on a roof or fabrication into a fence. The interior walls of a residence can also be constructed using the concrete panels and a plumbing circuit can be utilized to flow heated liquid through the panels, whereby the interior walls are warmed and the radiant heat warms rooms within the residence.

U.S. Patent No. 4,267,822 by Diamond discloses a solar energy system utilizing modular elements that are pre-cast from concrete and include
25 passageways through which a fluid is circulated for the transfer of energy. The modular units can be utilized as structural wall members having an inner layer, and an outer layer and a layer of thermal insulation can be disposed between the
30 inner and outer concrete layers. The outer layer functions as a solar collector and storage unit and the working fluid can be pumped from the outside layer to the inside layer to transmit heat into the room.

SUMMARY OF THE INVENTION

The present invention relates to a structural panel, a building structure incorporating a structural panel and a method of providing climate control within a building structure. According to one aspect, the panel is a concrete panel and
5 comprises an inner concrete layer and an outer concrete layer that are separated by an insulative layer. Conduits are formed in the inner concrete layer for the flow of a thermal transfer liquid through the inner concrete layer to provide heating or cooling of the inner concrete layer.

According to one embodiment, a unitary structural panel is provided where
10 the panel is adapted for use in the construction of a building. The structural panel can include a thermal insulation layer having mutually opposed first and second major surfaces. A first concrete layer is disposed adjacent to the first major surface of the thermal insulation layer and a second concrete layer is disposed adjacent to the second major surface of the thermal insulation layer. The first
15 concrete layer includes a fluid conduit where the conduit is adapted to convey a thermal transfer fluid through the first concrete layer. Inlet ports and outlet ports are disposed on opposite ends of the conduit to permit the injection and removal of a thermal transfer fluid. According to one aspect, the first concrete layer has a thickness that is greater than the thickness of the second concrete layer. By
20 increasing the thermal mass of the first concrete layer, the structural panel can provide more efficient heating and cooling to the interior of a building.

According to another embodiment, a unitary structural panel includes a thermal insulation layer having mutually opposed first and second major surfaces. A first concrete layer is disposed adjacent to the first major surface of the thermal
25 insulation layer and a second concrete layer is disposed adjacent to the second major surface of the thermal insulation layer. A fluid conduit is disposed within the first concrete layer where the conduit is adapted to convey a thermal transfer fluid through the first concrete layer. According to one aspect, a metallic layer is disposed between the first major surface of the thermal insulation layer and the
30 first concrete layer. The metallic layer can advantageously reflect radiant thermal energy back toward the first concrete layer to thereby increase the thermal efficiency of the structural panel.

According to another embodiment, a unitary structural panel is provided that is adapted for use in the construction of a building wall. The structural panel includes a thermal insulation layer comprising a closed cell foam and having mutually opposed first and second major surfaces. A first concrete layer is disposed adjacent to the first major surface of the thermal insulation layer. A fluid conduit is disposed within the first concrete layer where the conduit includes an inlet port and an outlet port, each of the ports being disposed on a top edge of the structural panel. The conduit is particularly adapted to convey a thermal transfer liquid through the first concrete layer. A second concrete layer is disposed adjacent to the second major surface of the thermal insulation layer, where the second concrete layer is substantially solid and wherein the first concrete layer has a thickness that is greater than the second concrete layer. In particular, according to one aspect, the second concrete layer does not include conduits for conveying a thermal transfer liquid through the second concrete layer.

According to another embodiment, a temperature regulating system for the interior of a building is provided. The system can include a means for detecting the temperature of an interior portion of the building, such as a thermostat. Means for adjusting the temperature of a thermal transfer fluid are also provided, where the temperature adjustment means are responsive to the temperature detecting means, and wherein the temperature adjusting means include means for both heating a thermal transfer fluid and for cooling a thermal transfer fluid. For example, a geothermal loop or a mechanical refrigeration unit can be utilized for cooling the thermal transfer fluid. A hot water heater, either actively or passively heated, can be used to heat the thermal transfer fluid. A pump for conveying the temperature-adjusted thermal transfer fluid from the temperature adjustment means through the concrete walls to change the temperature of the interior surface of the concrete walls is also provided.

According to yet another embodiment, a method for controlling the temperature of the interior of a building is provided. The building includes concrete walls having an interior concrete portion and an exterior concrete portion separated by a thermal insulation layer. The method includes adjusting the temperature of a thermal transfer fluid and then moving the thermal transfer fluid through a conduit that is disposed solely within the interior portion of the

concrete walls without moving the thermal transfer fluid through the exterior concrete portion. The thermal transfer fluid changes the temperature of the interior portion of the concrete walls, such as by heating or cooling, to thereby control the temperature of the interior portion of the building.

5

DESCRIPTION OF THE DRAWINGS

Fig. 1 illustrates a perspective view of a unitary structural panel that is useful for fabricating a wall of a building according to an embodiment of the present invention.

10 **Fig. 2** illustrates a cross-sectional side view of a unitary structural panel that is useful for fabricating a wall of a building according to an embodiment of the present invention.

Fig. 3 illustrates a cross-sectional front view of a unitary structural panel that is useful for fabricating a wall of a building according to an embodiment of
15 the present invention.

Fig. 4 illustrates a cross-sectional top view of a unitary structural panel that is useful for fabricating a wall of a building according to an embodiment of the present invention.

Fig. 5 illustrates a perspective view of a unitary structural panel including
20 an aperture that is useful for fabricating a wall of a building according to an embodiment of the present invention.

Fig. 6 illustrates multiple unitary structural panels that are interconnected to form a building wall in accordance with an embodiment of the present invention.

25 **Fig. 7** illustrates a schematic of a heating and cooling system incorporating structural wall panels according to an embodiment of the present invention.

DESCRIPTION OF THE INVENTION

The present invention relates to systems and methods for controlling the
30 climate within a building having an enclosed space, such as a personal residence or a commercial building. In particular, the present invention relates to concrete

structural panels that can be used for the walls of a building, where the structural panels include one or more fluid conduits for the passage of a thermal transfer fluid through the panel. The structural panels advantageously provide an efficient means for heating and cooling a building interior.

5 According to one embodiment, a building includes exterior walls and a roof defining an enclosed space. At least a portion of the exterior walls are fabricated from a unitary structural panel that includes inner and outer concrete layers and a thermal insulation layer disposed between the concrete layers. A fluid conduit is provided within the inner concrete layer, where the conduit is adapted to contain
10 a thermal transfer fluid, such as water and move the thermal transfer fluid through the inner concrete layer. By controlling the temperature of the thermal transfer fluid, the climate (e.g., the temperature) within the interior of the building can be controlled.

Referring to **Fig. 1** and **Fig. 2**, a structural panel according to one
15 embodiment of the present invention is illustrated. The structural panel **100** includes a thermal insulation layer **102** having a first major surface **102a** and a mutually opposed second major surface **102b**. A first (interior) concrete layer **104** is disposed adjacent to the first (inner) surface **102a** of the thermal insulation layer **102**, wherein the first concrete layer **104** includes a fluid conduit **108**
20 disposed within the first concrete layer **104** that is adapted to store and/or convey a thermal transfer fluid through the first concrete layer. A second (exterior) concrete layer **106** is disposed adjacent to the second (outer) major surface **102b** of the thermal insulation layer **102**. Preferably, the second concrete layer **106** is substantially solid, and in particular it is preferred that the second concrete layer
25 **106** not include fluid conduits therethrough, that the second concrete layer is not in fluid communication with the conduit **108** in the first concrete layer **104**, such that thermal transfer fluid is moved solely through the first concrete layer **104** without being moved through the second concrete layer **106**. This ensures that the heating or cooling affect of the thermal transfer fluid is applied only to the
30 interior portion of the panel.

The thermal insulation layer **102** is adapted to enhance the thermal resistance (e.g., the R-value) of the structural panel **100**. While the first concrete layer **104** has a large thermal mass, the thermal resistance of concrete is

relatively low, and therefore thermal transfer can cause the temperature of the interior wall surface **104a** to equilibrate with the exterior temperature in a short period of time. Accordingly, the thermal insulation layer **102** is selected to have a thermal resistance that is greater than the thermal resistance of either of the concrete layers, and preferably the thermal insulation layer has a thermal resistance of at least about R-10, more preferably at least about R-15. A variety of materials can be used for the thermal insulation layer **102**, and in one embodiment the insulation layer is fabricated from a closed cell foam. For example, the thermal insulation layer **102** can include a closed cell foam, such as the polystyrene closed cell foam available under the trademark STYROFOAM from the Dow Chemical Company. Closed cell foams of this type are structurally rigid, have good thermal resistance and are resistant to attack by moisture.

According to another embodiment, the thermal insulation layer **102** comprises a natural product, or a natural product derivative that is not derived from petrochemicals. For example, soy insulation, cellulose-based insulation, wheat straw or similar natural thermal insulation products can be used.

The thermal insulation layer **102** should have a thickness that is sufficient to provide good insulative properties to the structural panel **100** without significantly compromising the structural strength of the panel **100**. According to one embodiment, the thermal insulation layer has a thickness of at least about 1 inch (about 2.5 cm), and preferably has a thickness that is not greater than about 3 inches (about 7.6 cm).

The first (interior) concrete layer **104** and a second (exterior) concrete layer **106** are disposed on opposite sides of the thermal insulation layer **102**. As used herein, the term concrete refers to any cementitious material, and can include aggregates in addition to the cementitious material. The cementitious material can be, for example, Portland cement or can include materials such as pozzolans, fly ash or blast furnace slag.

The first concrete layer **104**, which in the construction of a building is disposed facing the interior portion of the building, includes a fluid conduit **108** disposed within the concrete layer **104**, where the conduit **108** is adapted to convey a thermal transfer liquid through the first concrete layer **104**. The conduit preferably has a substantially circular cross-section to facilitate the flow of a liquid

through the conduit, and preferably has a diameter of at least about 0.5 inch (1.3 cm) and not greater than about 0.75 inch (1.9 cm).

As is more clearly illustrated in the cross-sectional view of **Fig. 3**, the conduit **108** can have a serpentine-like configuration to enhance the evenness of the heat transfer from the thermal transfer fluid to the interior surface **104a** of the concrete layer **104**. In the configuration illustrated in **Fig. 3**, a thermal transfer fluid is injected into the conduit through an inlet port **110** and initially flows generally downwardly through the panel **100**. A rounded portion **122** of the conduit **108** causes the fluid to then flow generally upwardly through the panel. This change in direction of fluid flow can occur one or several times depending upon the width of the panel **100**. Preferably, the conduit **108** includes generally linear portions **120** that are disposed in substantially parallel relation to adjacent linear portions. After traversing the panel **100** in this manner, the thermal transfer fluid is withdrawn through an outlet port **112**. It is preferred that the conduit **108** comprise a single flow channel to maintain essentially plug flow conditions for the fluid through the conduit. Preferably, the conduit **108** comprises tubing disposed through the first concrete layer **104**, such as metal tubing (e.g., copper) or plastic tubing. Composite tubing can also be utilized, including tubing having an exterior metal surface and an interior plastic surface.

The linear portions **120** of the conduit can be sufficiently spaced apart to retain structural integrity of the panel and spaced sufficiently close together to provide adequate thermal transfer (heating and cooling) to the interior space of a building. Accordingly, in one embodiment the conduit **108** is disposed in the first concrete layer **104** such that at least the adjacent linear portions of the conduit are disposed in substantially parallel relation, and such linear portions of the adjacent conduits are spaced apart (i.e., center-to-center) by at least about 2 inches (about 5.1 cm), such as at least about 6 inches (about 15.2 cm). However, to provide for adequate heating or cooling of the first concrete layer **104**, the conduits are preferably spaced by not greater than about 36 inches (about 91 cm), such as by not greater than about 30 inches (about 76 cm).

According to the present invention, it is preferred that the first (interior) concrete layer **104** has a thickness that is greater than the thickness of the second (exterior) concrete layer **106**. In one embodiment the first concrete layer

104 has a thickness that is at least about 1.5 times, such as at least about 2 times, greater than the thickness of the second concrete layer **106**. It is an advantage of this aspect of the present invention that the thermal mass of the first concrete layer **104** is greater than the thermal mass of the second concrete layer **106** by virtue of an increased thickness. The high thermal mass of the first concrete layer **104** and the insulating affect of the thermal insulation layer **102** increase the heating and cooling efficiency of the panel by maximizing the capacity of the first concrete layer to maintain its thermal state over an extended period of time.

10 In this regard, the first concrete layer **104** is sufficiently thick to accommodate the conduits and to provide a sufficient thermal mass to provide efficient heating and cooling to the building interior. Accordingly, the first concrete layer preferably has a thickness of at least about 4 inches (about 10.2 cm), such as at least about 6 inches (about 15.2 cm). However, the thickness of the first concrete layer **104** is preferably not greater than about 12 inches (30.5 cm), such as not greater than about 10 inches (25.4 cm). Further, the fluid conduit can advantageously be disposed about one-half way through the thickness of the first concrete layer **104**, or can be disposed closer to the interior surface **104a**.

20 The second concrete layer **106** is preferably substantially solid, and in particular it is preferred that the second concrete layer **106** does not include conduits of a similar nature as those in the first concrete layer **104**. As is noted above, the second concrete layer **106** preferably has a thickness that is less than the thickness of the interior concrete layer **104**. Accordingly, in one embodiment 25 the second concrete layer **106** has a thickness of at least about 2 inches (about 5.1 cm), such as at least about 3 inches (about 7.6 cm). Preferably, the thickness is not greater than about 6 inches (about 15.2 cm), such as not greater than about 5 inches (about 12.7 cm).

30 Accordingly, the unitary structural panel **100** preferably has a total thickness of at least about 8 inches (20.3 cm), more preferably at least about 10 inches (25.4 cm), and the thickness is preferably not greater than about 14 inches (35.6 cm), such as not greater than about 12 inches (30.5 cm).

The dimensions (height and width) of the panel **100** can be sized to accommodate a variety of building structures. For example, the panels can be substantially square with sides having a length of at least about 4 feet (about 1.2 meters) and not greater than about 12 feet (about 3.7 meters). The panels can
5 also be of other rectangular configurations, such as panels having a width of from about 4 feet (about 1.2 meters) to about 14 feet (about 4.3 meters) and a height that is 10 feet (about 3.0 meters), 12 feet (about 3.7 meters) or even higher.

According to one embodiment, and as illustrated in the cross-sectional top view of **Fig. 4**, the structural panel **100** can also include a metallic layer **116**
10 disposed between the thermal insulation layer **102** and the first concrete layer **104**. The metallic layer **116** is adapted to reflect thermal radiation back to the first concrete layer **104**, thereby improving the thermal efficiency of the panel **100**. For example, the metallic layer **116** can be a thin metal sheet, such as an aluminum sheet, adjoining the first major surface **102a** thermal insulation layer
15 **102**. Preferably, the metallic layer **116** is thin, and in one embodiment has a thickness of not greater than about 0.5 inch (about 1.3 cm). A second metallic layer (not illustrated) can also be provided between the second major surface **102b** of the insulative layer **102** and the second concrete layer **106** to reflect thermal radiation back to the exterior of the panel **100**.

20 During fabrication of the structural panel **100**, the metallic layer **116** can be chemically attacked by the cementitious material of the first concrete layer **104** before the cementitious material fully sets. Therefore, a protective barrier layer (not illustrated) can advantageously be disposed between the metallic layer **116** and the first concrete layer **104** to reduce or prevent such degradation. As an
25 example, a thin layer of plastic can be disposed between the first concrete layer **104** and the metallic layer **116**. Also, an additional thin layer of thermal insulation such as closed cell foam can be provided between the reflective layer **116** and the first concrete layer **104**.

Referring back to **Fig. 1**, the panel **100** can be mounted to form a portion
30 of a wall unit by mounting the panel **100** onto a footer **130**. For example, the panel **100** can be attached to the footer **130** by welding embedded metal plates **132** to corresponding metal plates on the footer **130**. Further, top metal plates **134** can be attached on a top edge **114** of the panel such that adjacent panels

can be connected along the top edge **114** by welding to a connector plate **136**. As is known to those skilled in the art, after securing the panels to the footer **130** and to adjacent panels, any gaps or seams can be sealed to prevent ingress and egress of moisture and air.

5 In addition, the panel **100** can be provided with utility conduits **126** and utility boxes **128** for the placement of electrical and telecommunications wiring.

 In the embodiment illustrated in **Fig. 5**, the panel **100** also includes an aperture **124** that is adapted for the placement of a window or similar structure in the panel. In this regard, the fluid conduit **108** can be placed around the aperture
10 **124** to evenly control the temperature of the first concrete layer **104**.

 The structural panels according to the present invention can be produced in the following manner. A form having borders, such as a wooden form, is provided in the desired size and shape of the panel. The exterior portion of the structural panel is formed by pouring wet concrete into the form to the desired
15 depth, such as about 3 inches (7.6 cm). Thereafter, a thermally insulative material is placed over the poured concrete layer. Preferably, the thermally insulative material is placed over the poured concrete when the poured concrete is still wet and has not completely dried. Fastening means, such as structural ties can be used to affix the thermally insulative material to the exterior concrete
20 layer, if necessary. The thermally insulative material can also have a reflective layer pre-attached to the thermally insulative material.

 Wire mesh can be utilized to support the tubing that will comprise the fluid conduit. In this regard, a plurality of supports can be placed on the insulative material to support the wire mesh. The height of these supports will determine
25 the depth of the conduit within the interior concrete layer. According to one embodiment, the supports have a height that will place the conduit at a distance about one-half way through the first (interior) concrete layer.

 After placement of the supports on the thermal insulation, the wire mesh is placed on the supports. To form the fluid conduit, tubing, preferably having an
30 outer diameter of from about 0.5 inch to about 0.75 inch, is attached to the wire mesh in a desired configuration such as a serpentine configuration. The tubing can be attached to the wire mesh prior to placement of the mesh onto the

supports or after the wire mesh is placed onto the supports. The tubing can be metallic tubing such as copper, or can be plastic tubing. Composite tubing can also be utilized, such as that sold under the tradename KiTEC available from KiTEC Industries (India) Limited. KiTEC is an aluminum and polyethylene composite where the polyethylene layer is disposed on the inner diameter of the tubing. The composite tubing combines the features of both materials to form a pipe that is light, strong and does not support corrosion. By combining the two materials, composite tubing avoids the thermal expansion and deformation of plastic pipe, and at the same time it retains the flexibility, frost resistance and ease of use associated with plastic.

In addition to the tubing utilized to form the thermal transfer fluid conduit, conduits for electrical wiring through the interior concrete layer can be formed by attaching tubing materials to the wire mesh. Boxes for electrical outlets and similar access ports can be provided extending from the tubing such that the access ports form in the concrete layer when the concrete is poured.

Further, metal connection plates can be provided on the upper and lower peripheral edges of the panel to enable the panel to be welded to adjacent panels and also to be welded to a supporting footer during construction of the building.

After pouring of the interior concrete layer, the panel is allowed to dry and is then ready for installation. The panels can be pre-fabricated and shipped to the construction site, or can be fabricated on-site. It will also be appreciated that the foregoing method can be adapted for fabricating the panels on-site by pouring-in-place, i.e., fabricating the panels in a vertical orientation to form a wall unit.

The present invention is also directed to a building structure and climate control system that include a wall unit fabricated using one or more structural panels, such as those described above.

For example, **Fig. 6** illustrates three structural wall panels **200a**, **200b** and **200c** that are interconnected to form a wall unit. In this regard, the fluid conduit **208a** of panel **200a** and the fluid conduit **208b** of panel **200b** are interconnected by fluid connection **230** such that the thermal transfer fluid flows into panel **200a** and then through panel **200b** before being transferred out of the panels for

adjusting (raising or lowering) the temperature of the thermal transfer fluid for return to the panels. Thus, panels **200a** and **200b** define a first temperature zone (Zone I). A second zone (Zone II) includes panel **200c** where a thermal transfer fluid is passed through the conduit **208c** and is then removed to have the temperature of the fluid adjusted. Zone I and Zone II can be operated independently depending on the desired heating or cooling requirements of the interior. In this regard, the structural panels of the present invention advantageously enable panels to be interconnected to form a single climate zone, or to be operated independently to form multiple climate zones. For example, the cooling requirements for structural walls disposed on the southern-facing side of a building may be higher than those disposed on the northern-facing side of the building.

The present invention is also directed to a system and method for regulating the climate, particularly the temperature, within the interior of a building. The building can include walls having an interior surface facing the interior of the building and an exterior surface disposed on the exterior of the building. A thermal transfer fluid, such as water, can be passed through the walls near the interior surface of the walls to provide heating or cooling.

Fig. 7 schematically illustrates a portion of a heating and cooling system according to an embodiment of the present invention. This system includes panels **200a**, **200b** and **200c** as is described above. A hot water source **232** and a cold water source **234** are connected to a water header **236**, where the water header **236** controls the flow of water to the panels within the system. The water header **236**, as well as the hot water source **232** and the cold water source **234**, can be connected to one or more thermostats, which detect the interior temperature and control the water temperatures and/or water flows to various zones within the system. Thus, as is illustrated in **Fig. 7**, the water header **236** can provide hot or cold water to either of Zone I or Zone II depending on the heating and cooling requirements. Pumps (not illustrated) can provide sufficient pressure to move the water through the panels and maintain adequate fluid circulation within the system. Although the bulk of the water can be stored within the panels and/or within the hot or cold water sources, an optional water storage unit **238** can be utilized to store a portion of the water.

The hot water source can include a traditional active hot water heater having a storage tank, including one that is heated by electricity or gas. The hot water source **232** can also be an "instant", or on-demand, hot water heater that does not include a storage tank for the temporary storage of the hot water. The hot water heater can optionally be powered in whole or in part, for example, using photovoltaics or other solar means to enhance the energy efficiency of the system. The water can also be passively heated using solar panels, such as solar panels disposed on a roof of the building.

According to the present invention, the system can also include a cold water source **234** to provide cooling to the interior of the building when needed. The cold water source **234** can include a geothermal loop to cool water by passing the water through channels buried within the ground beneath or near the building. Other cold water sources, such as mechanical refrigeration units, can also be used to cool the water.

Thus, the structural panels and heating and cooling systems of the present invention advantageously provide an economical and environmentally friendly means for heating and cooling the interior of a building. Specifically, it has been found that the use of a thermal transfer fluid to heat and cool the interior surface of the relatively large thermal mass interior wall can efficiently heat and cool a building interior.

While various embodiments of the present invention have been described in detail, it is apparent that modifications and adaptations of those embodiments will occur to those skilled in the art. However, it is to be expressly understood that such modifications and adaptations are within the spirit and scope of the present invention.

What is Claimed is:

1. A unitary structural panel adapted for use in the construction of a building wall, the structural panel comprising:

5 a thermal insulation layer having mutually opposed first and second major surfaces;

a first concrete layer disposed adjacent to the first major surface of the thermal insulation layer;

10 a fluid conduit disposed within the first concrete layer where the conduit is adapted to convey a thermal transfer fluid through the first concrete layer;

an inlet port at a first end of the conduit;

an outlet port at a second end of the conduit; and

15 a second concrete layer disposed adjacent to the second major surface of the thermal insulation layer, where the first concrete layer has a thickness that is greater than the thickness of the second concrete layer.

2. A unitary structural panel as recited in Claim 1, wherein the thermal insulation layer comprises a closed cell foam.

20 3. A unitary structural panel as recited in Claim 1, wherein the thermal insulation layer has a thickness of at least about 1 inch and not greater than about 3 inches.

4. A unitary structural panel as recited in Claim 1, further comprising:
a metallic reflective layer disposed between the thermal insulation layer and the first concrete layer.

25 5. A unitary structural panel as recited in Claim 1, further comprising:
a metallic reflective layer disposed between the thermal insulation layer and the first concrete layer; and

a protective barrier layer disposed between the metallic reflective layer and the first concrete layer.

30 6. A unitary structural panel as recited in Claim 1, wherein the second concrete layer is substantially solid.

7. A unitary structural panel as recited in Claim 1, wherein the first concrete layer has a thickness that is at least about 1.5 times greater than the thickness of the second concrete layer.

8. A unitary structural panel as recited in Claim 1, wherein the first
5 concrete layer has a thickness that is at least about 2 times greater than the thickness of the second concrete layer.

9. A unitary structural panel as recited in Claim 1, wherein the first concrete layer has a thickness of at least about 4 inches and not greater than about 12 inches.

10. A unitary structural panel as recited in Claim 1, wherein the fluid
10 conduit traverses the first concrete layer in a serpentine configuration.

11. A unitary structural panel as recited in Claim 1, wherein the inlet port and the outlet port are each disposed on a top edge of the structural panel.

12. A unitary structural panel as recited in Claim 1, wherein at least
15 portions of the conduit are disposed in the first concrete layer in substantially parallel relation and adjacent conduits in the parallel portions are spaced apart by at least about 6 inches.

13. A unitary structural panel as recited in Claim 12, wherein the adjacent parallel portions are spaced apart by not greater than about 30 inches.

14. A unitary structural panel as recited in Claim 1, wherein the second
20 concrete layer has a thickness of at least about 2 inches and not greater than about 6 inches.

15. A unitary structural panel adapted for use in the construction of a building wall, the structural panel comprising:

25 a thermal insulation layer having mutually opposed first and second major surfaces;

a first concrete layer disposed adjacent to the first major surface of the thermal insulation layer;

30 a fluid conduit disposed within the first concrete layer where the conduit is adapted to convey a thermal transfer fluid through the first concrete layer;

a metallic layer disposed between the first major surface of the thermal insulation layer and the first concrete layer; and

a second concrete layer disposed adjacent to the second major surface of the thermal insulation layer.

5 16. A unitary structural panel as recited in Claim 15, wherein the metallic reflective layer comprises aluminum.

17. A unitary structural panel as recited in Claim 15, wherein the metallic reflective layer has a thickness of not greater than about 0.5 inches.

10 18. A unitary structural panel as recited in Claim 15, further comprising:
a protective barrier layer disposed between the metallic reflective layer and the first concrete layer.

19. A unitary structural panel as recited in Claim 15, wherein the first concrete layer has a thickness that is at least about 1.5 times greater than the thickness of the second concrete layer.

15 20. A unitary structural panel as recited in Claim 19, wherein the first concrete layer has a thickness of at least about 4 inches.

21. A unitary structural panel as recited in Claim 20, wherein the second concrete layer has a thickness of at least about 2 inches and not greater than about 6 inches.

20 22. A unitary structural panel adapted for use in the construction of a building wall, the structural panel and having a top edge and a bottom edge, comprising:

a thermal insulation layer comprising a closed cell foam and having mutually opposed first and second major surfaces;

25 a first concrete layer disposed adjacent to the first major surface of the thermal insulation layer;

a fluid conduit disposed within the first concrete layer, where the conduit comprises an inlet port and an outlet port, each of the ports being disposed on a top edge of the panel, where the conduit is adapted to convey a thermal transfer liquid through the first concrete layer; and
30

a second concrete layer disposed adjacent to the second major surface of the thermal insulation layer, the second concrete layer being substantially solid, wherein the first concrete layer has a thickness that is greater than the second concrete layer.

5 23. A temperature regulating system for the interior of a building, the building including concrete walls having an interior surface, the system comprising:

means for detecting the temperature of an interior portion of the building;

10 means for adjusting the temperature of a thermal transfer fluid, where the temperature adjustment means are responsive to the temperature detecting means and comprise means for heating a thermal transfer fluid and for cooling a thermal transfer fluid; and

15 means for conveying the temperature adjusted thermal transfer fluid from the temperature adjustment means through the concrete walls to change the temperature of the interior surface of the concrete walls.

24. A system as recited in Claim 23, wherein the temperature adjusting means comprises a geothermal loop for cooling the thermal transfer fluid.

20 25. A system as recited in Claim 23, wherein the cooling means comprises mechanical refrigeration unit for cooling the thermal transfer fluid.

26. A system as recited in Claim 23, wherein the temperature adjusting means further comprises a hot water heater for heating the thermal transfer fluid.

25 27. A method for controlling the temperature of the interior of a building, the building comprising concrete walls having an interior concrete portion and an exterior concrete portion separated by a thermal insulation layer, the method comprising the steps of:

adjusting the temperature of a thermal transfer fluid;

30 moving the thermal transfer fluid through a conduit that is disposed solely within the interior portion of the concrete walls without moving the thermal transfer fluid through the exterior concrete portion, wherein the thermal transfer fluid changes the temperature of the interior portion of the

concrete walls to thereby control the temperature of the interior portion of the building.

28. A method as recited in Claim 27, wherein the step of adjusting the temperature of the thermal transfer fluid comprises heating the thermal transfer fluid.

29. A method as recited in Claim 27, wherein the step of adjusting the temperature of the thermal transfer fluid comprises heating water using an active hot water heater.

30. A method as recited in Claim 27, wherein the step of adjusting the temperature of the thermal transfer fluid comprises heating water using a hot water heater, wherein electricity is provided to the hot water heater by a photovoltaic cell.

31. A method as recited in Claim 27, wherein the step of adjusting the temperature of the thermal transfer fluid comprises cooling the heat transfer fluid.

32. A method as recited in Claim 27, wherein the step of adjusting the temperature of the thermal transfer fluid comprises cooling the heat transfer fluid using a geothermal loop.

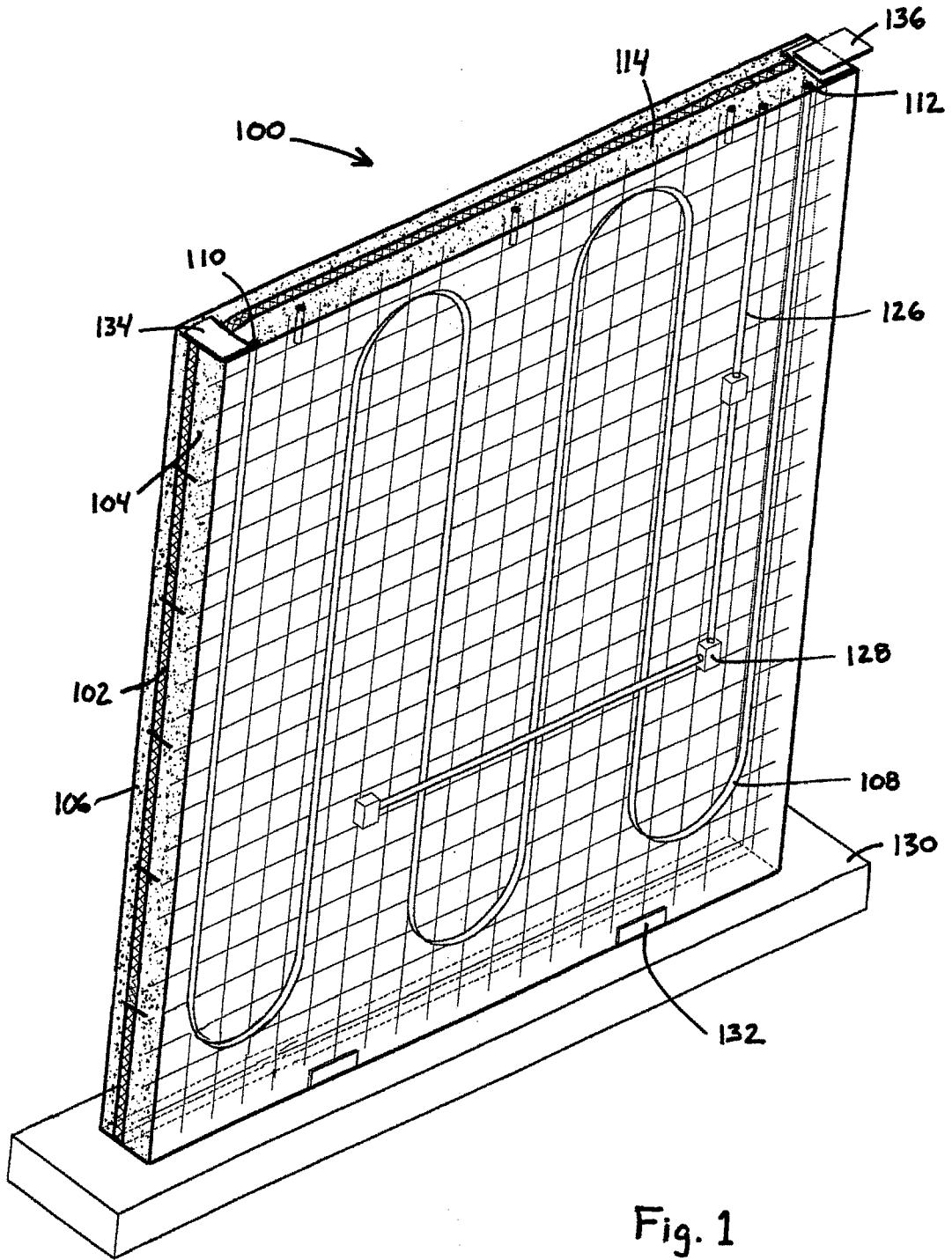

Fig. 1

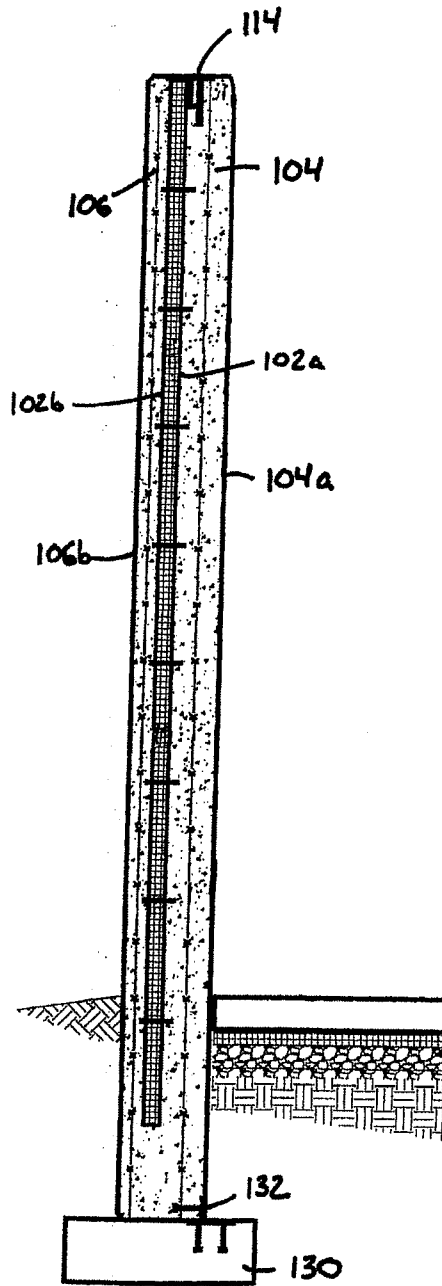

Fig. 2

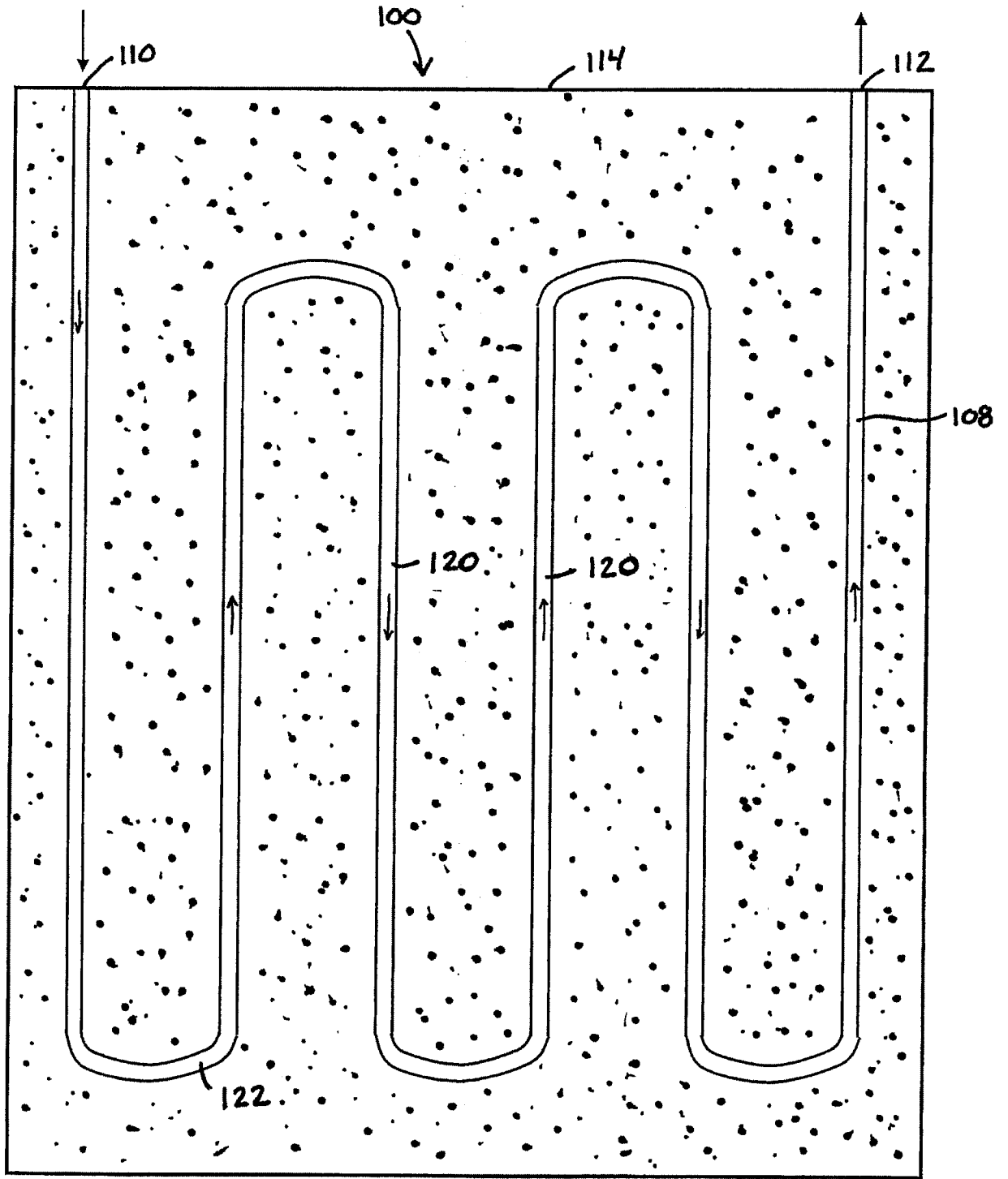

Fig. 3

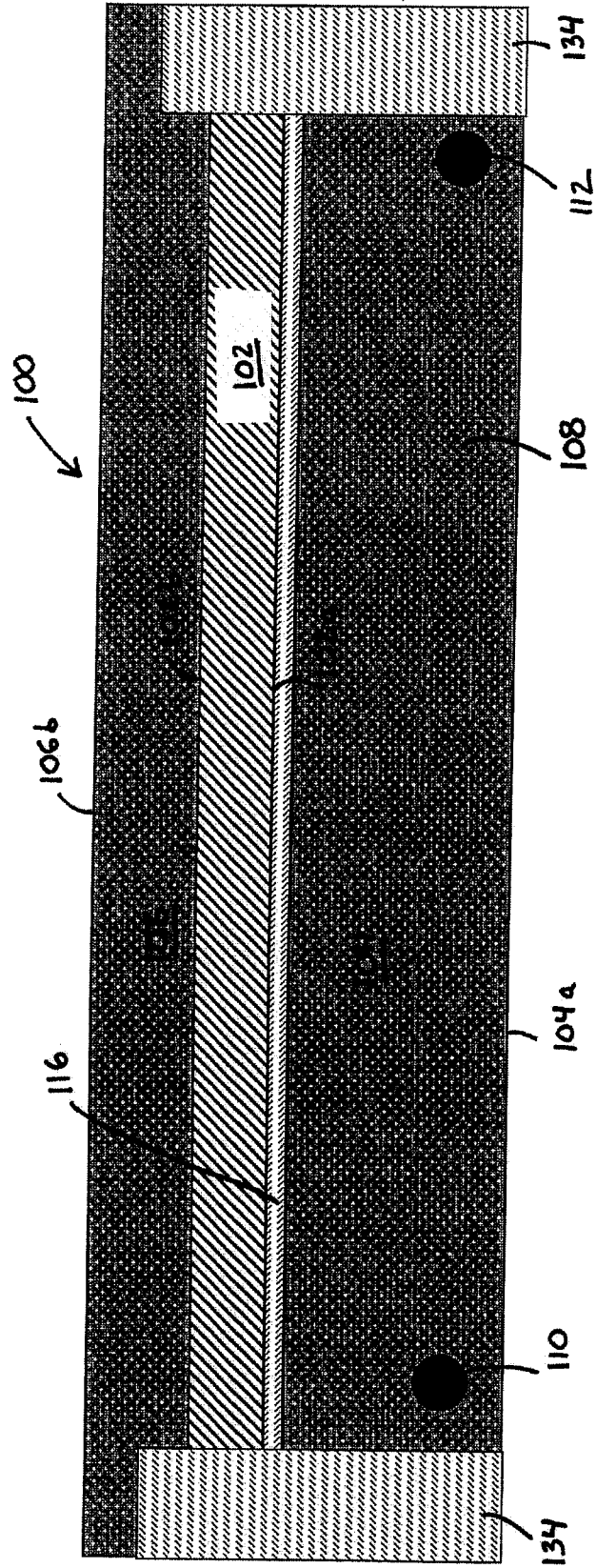

Fig. 4

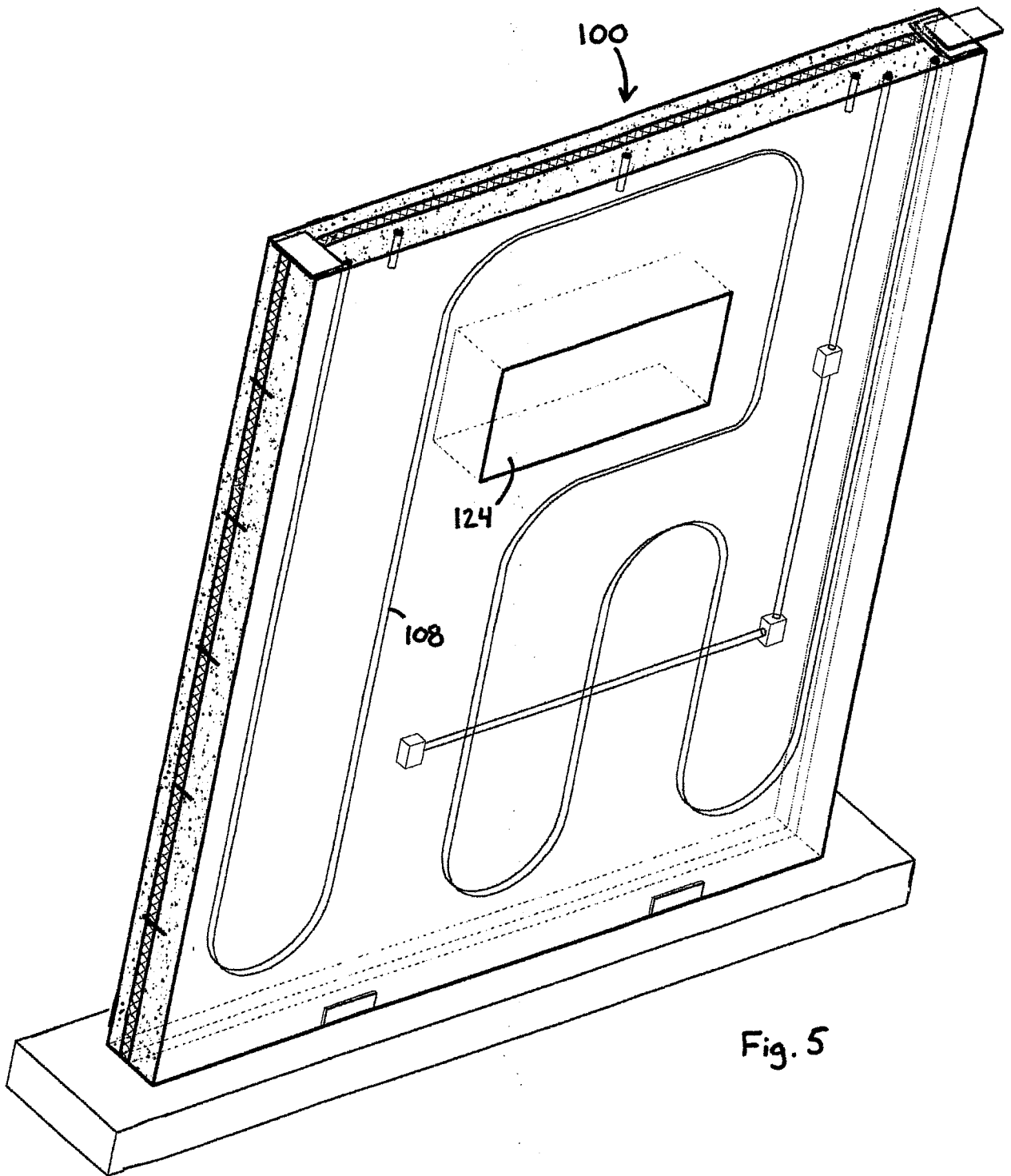

Fig. 5

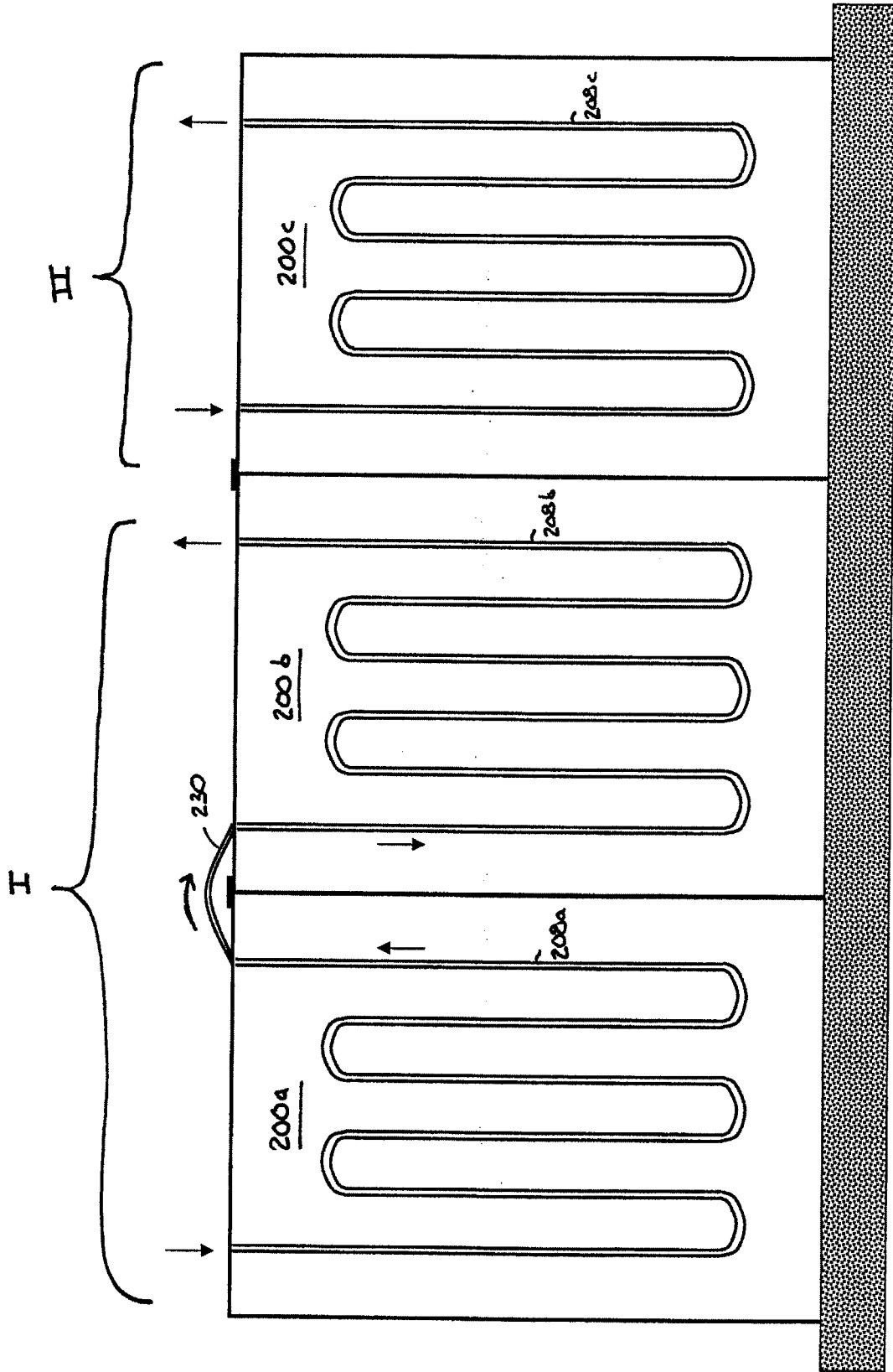

Fig. 6

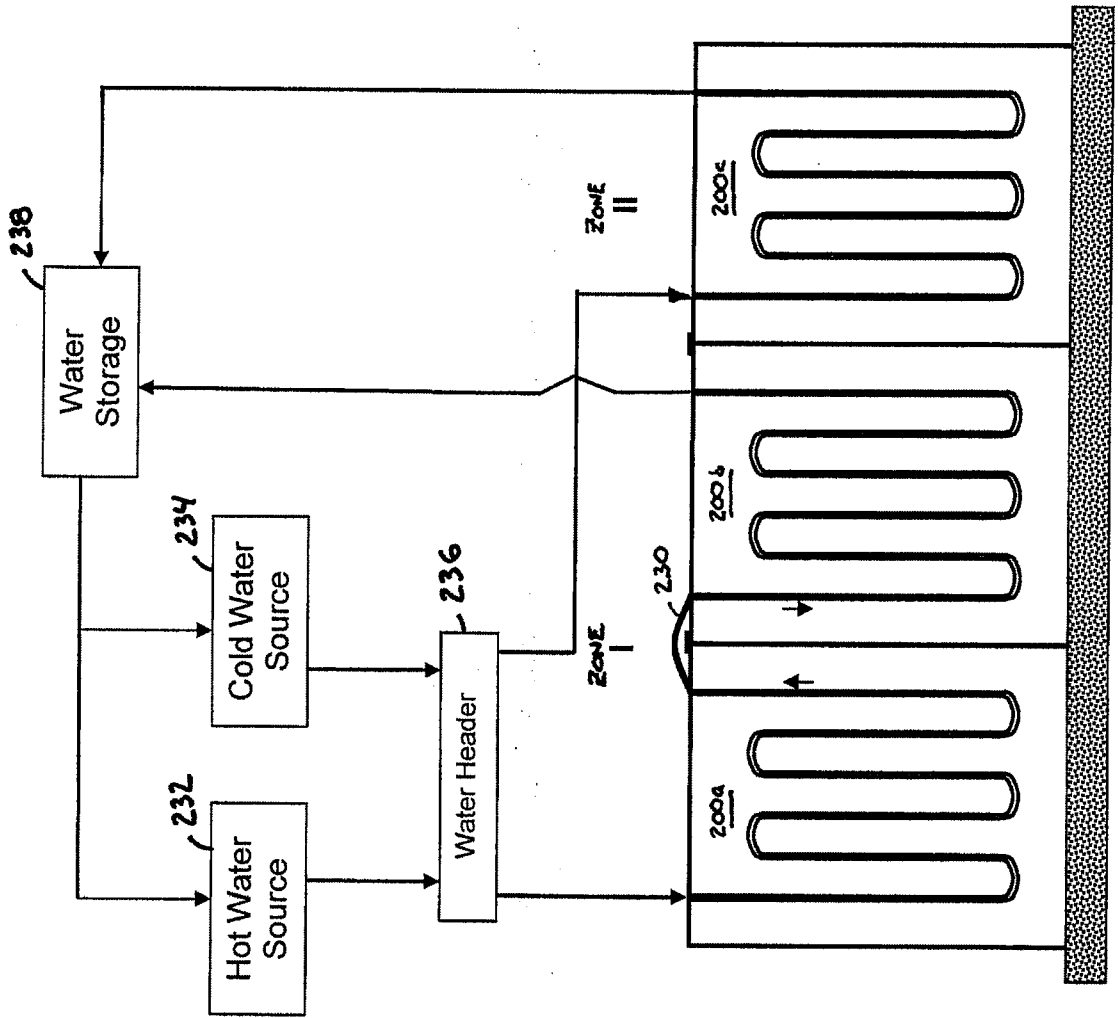

Fig. 7

INTERNATIONAL SEARCH REPORT

International application No.

PCT/US 08/68663

A. CLASSIFICATION OF SUBJECT MATTER
 IPC(8) - F24H 7/02 (2008.04)
 USPC - 126/633; 165/168
 According to International Patent Classification (IPC) or to both national classification and IPC

B. FIELDS SEARCHED

Minimum documentation searched (classification system followed by classification symbols)
 USPC: 126/633; 165/168

Documentation searched other than minimum documentation to the extent that such documents are included in the fields searched
 USPC: 126/400, 572, 583, 587, 609, 613, 615, 633, 640, 709; 165/49, 53, 168; 52/168, 220.2, 577; search terms below

Electronic data base consulted during the international search (name of data base and, where practicable, search terms used)
 Delphion [German (Applications - Full text), German (Granted - Full text), European (Applications - Full text), European (Granted - Full text), INPADOC, Abstracts of Japan, US (Granted - Full text), WIPO PCT Publications (Full text), US (Applications - Full text)]; Google Scholar; thermal, layers, concrete, building, wall

C. DOCUMENTS CONSIDERED TO BE RELEVANT

Category*	Citation of document, with indication, where appropriate, of the relevant passages	Relevant to claim No.
X -- Y	US 4,267,822 A (DIAMOND) 19 May 1981 (19.05.1981), abstract, fig 17, col 7, ln 3-42.	1-3, 6-14, and 22 ----- 4-5, 15-21, and 23-32
Y	US 3,929,186 A (BECKER) 30 December 1975 (30.12.1975), abstract, fig 12-13, col 7, ln 25-55, col 8, ln 58 to col 9, ln 35.	4-5, 15-21, and 23-32
A	US 5,060,718 A (CAPILLI et al.) 29 October 1991 (29.10.1991), abstract, fig 1-13.	1-32
A	US 4,741,391 A (SCHMITZ) 03 May 1988 (03.05.1988), abstract, fig 1-6.	1-32

Further documents are listed in the continuation of Box C.

* Special categories of cited documents:	"T" later document published after the international filing date or priority date and not in conflict with the application but cited to understand the principle or theory underlying the invention
"A" document defining the general state of the art which is not considered to be of particular relevance	"X" document of particular relevance; the claimed invention cannot be considered novel or cannot be considered to involve an inventive step when the document is taken alone
"E" earlier application or patent but published on or after the international filing date	"Y" document of particular relevance; the claimed invention cannot be considered to involve an inventive step when the document is combined with one or more other such documents, such combination being obvious to a person skilled in the art
"L" document which may throw doubts on priority claim(s) or which is cited to establish the publication date of another citation or other special reason (as specified)	"&" document member of the same patent family
"O" document referring to an oral disclosure, use, exhibition or other means	
"P" document published prior to the international filing date but later than the priority date claimed	

Date of the actual completion of the international search 06 October 2008 (06.10.2008)	Date of mailing of the international search report 10 OCT 2008
Name and mailing address of the ISA/US Mail Stop PCT, Attn: ISA/US, Commissioner for Patents P.O. Box 1450, Alexandria, Virginia 22313-1450 Facsimile No. 571-273-3201	Authorized officer: Lee W. Young PCT Helpdesk: 571-272-4300 PCT OSP: 571-272-7774