

Nov. 29, 1955

W. M. HOOVER

2,725,231

ROWING MACHINE

Filed June 1, 1953

FIG. 1.

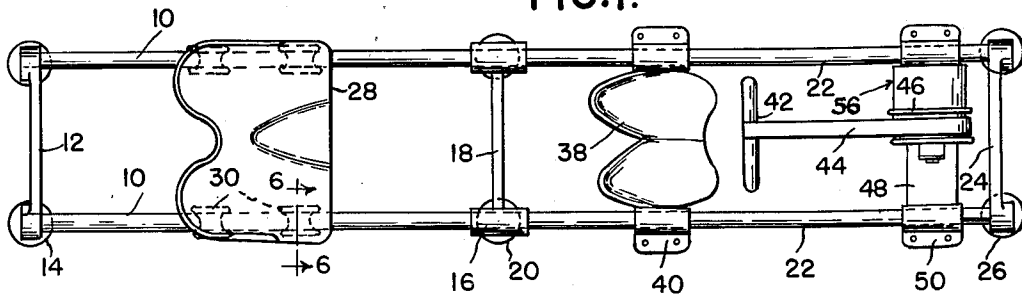

FIG. 2.

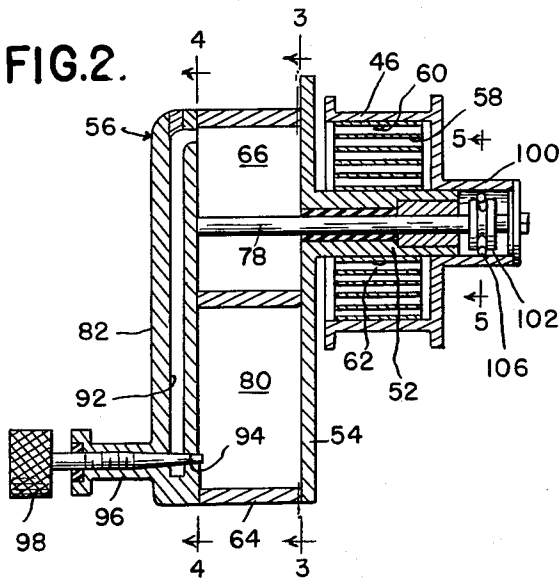

FIG. 3.

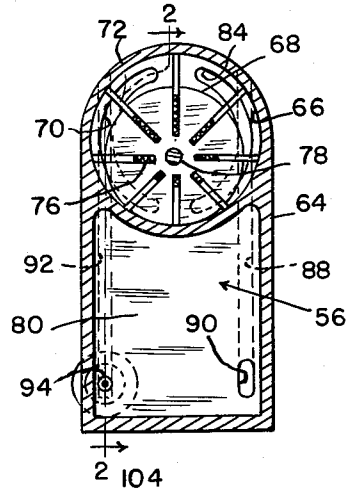

FIG. 4.

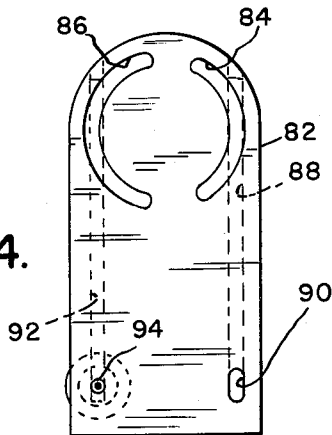

FIG. 5.

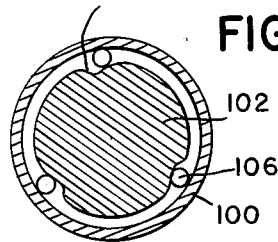
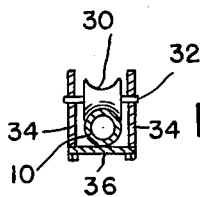

FIG. 6.



INVENTOR.

WALTER M. HOOVER

BY *Whittemore*

Hulbert & Belknap
ATTORNEYS

1

2,725,231

ROWING MACHINE

Walter M. Hoover, Grosse Pointe, Mich., assignor of one-half to John L. Powers, Wyandotte, Mich.

Application June 1, 1953, Serial No. 358,731

12 Claims. (Cl. 272—72)

The present invention relates to a rowing machine designed for exercise and practice purposes which closely simulates the action of a conventional racing shell.

It is an object of the present invention to provide a rowing machine characterized by its simplicity, the fact that it may be separated into major components to facilitate storage, the action by means of which the resistance to movement of an oar may be simulated, and by the economy with which the machine may be produced.

More specifically, it is an object of the present invention to provide a rowing machine comprising rails, a seat movable longitudinally on the rails, a foot rest forwardly of the seat, a drum mounted forwardly of the foot rest, a belt wound upon the drum, a handle carried by the outer end of the belt, and adjustable pump means for opposing rotation of the drum in a direction to unwind the belt therefrom.

It is a further object of the present invention to provide a rowing machine as described in the preceding paragraph, in combination with spring means operatively connected to the drum tending to rotate the drum in a direction to wind the belt thereon, and a one-way or over-running clutch adapted to connect the drum to a rotary pump element during rotation of the drum in response to withdrawal of the belt therefrom.

Other objects and features of the invention will become apparent as the description proceeds, especially when taken in conjunction with the accompanying drawings, wherein:

Figure 1 is a plan view of the rowing machine.

Figure 2 is a fragmentary section through the pump and drum mechanism, taken on the line 2—2, Figure 3, with parts omitted for clarity.

Figure 3 is a section on the line 3—3, Figure 2.

Figure 4 is a section on the line 4—4, Figure 2.

Figure 5 is an enlarged section on the line 5—5, Figure 2.

Figure 6 is a section on the line 6—6, Figure 1.

The rowing machine comprises a pair of rails 10 interconnected at the rear end of the machine by a cross piece 12 supported in elevated condition by depending legs 14. The forward ends of the rails 10 are received in sleeves 16 carried by a cross piece 18 supported in elevated position by depending legs 20. Forwardly of the cross piece 18 is a frame portion comprising a pair of spaced parallel frame elements 22 interconnected at their forward ends by a cross piece 24 carried in elevated position by legs 26. Conveniently, the rails 10 may be formed of pipe and the frame elements 22 may be formed of pipe identical with the rail sections 10.

Mounted on the rails 10 is a seat 28 having at each side thereof pairs of rollers 30 as best illustrated in Figure 6, these rollers being mounted on a spindle 32 carried by depending brackets 34 on the seat. The lower end of the brackets 34 is preferably connected by a cross piece 36 which, as is apparent in Figure 5, retains the seat in operating position on the rails 10. Interconnecting the

2

frame elements 22 is a foot rest indicated generally at 38, the foot rest having brackets 40 at opposite ends adapted to be clamped to the frame elements 22. Located at the front end of the machine is oar simulating mechanism which includes a handle 42 carried at the outer end of a flexible belt 44 which is wound upon a drum 46. The oar simulating mechanism is carried by a cross piece 48 the opposite ends of which are provided with clamps 50 for mounting the mechanism on the frame elements 22.

Preferably, the rear ends of the frame elements 22 are quickly detachable from the sleeves 16 to facilitate storage of the rowing machine in a small space. It will be appreciated that when the frame elements 22 are separated from the sleeves 16, they are retained in proper spaced relation by the foot rest 38. Separation of the forward end of the machine from the rear end thereof leaves the rails 10 interconnected at both their forward and rear ends by the cross pieces 18 and 12, the seat 28 remaining assembled with the rails.

Reference is now made particularly to Figures 2-5 for illustrating details of the oar simulating mechanism. The drum 46 is mounted for rotation on a hub 52 which extends outwardly from a closure plate 54 constituting a part of a pump casing indicated generally at 56. Interconnecting the drum 46 and the hub 52 is a phonograph type spring 58 one end of which is riveted or otherwise secured to an inner surface of the drum as indicated at 60, and the other end of which is correspondingly secured to the hub 52 as indicated at 62.

The pump casing generally indicated at 56 includes an intermediate part 64 the configuration of which is best seen in Figure 3. Adjacent the upper end of the part 64 is a circular pump chamber 66 in which is rotatably mounted a pump element 68. In Figure 3 the pump element 68 is illustrated as of a type having radial slots 70 in which are slidably received vanes 72 urged outwardly by compression springs 76 received in the bottom of the slots. The rotary pump element 68 is mounted for rotation about the axis of a shaft 78 which is located eccentrically with respect to the cylindrical pump chamber 66. Accordingly, as the rotary pump element 68 is driven in rotation, the vanes 72 move inwardly and outwardly of the slots and propel fluid ahead of the vanes.

The element 64 includes a lower enlargement 80 constituting a fluid reservoir for the hydraulic fluid.

The pump casing comprises a third element 82 which as best seen in Figure 4, includes a pair of valve ports 84 and 86. The port 84 is an inlet port and communicates with the reservoir through a cored passage 88 which in turn communicates with a port 90 on the inner surface of the element 82, the port 90 of course being located in the reservoir. The element 82 includes a discharge passage 92 which communicates with the discharge port 86 and communicates with the interior of the reservoir 80 through a small port 94. The element 82 includes an outwardly extending projection 96 having an internally threaded bore receiving a needle valve 98 by means of which the restriction afforded by the port 94 may be adjustably varied. From the foregoing it will be observed that when the rotary pump element 68 is rotated counterclockwise as seen in Figure 3, hydraulic fluid is drawn through the reservoir inlet port 90, upwardly through the passage 88 into the interior of the pump chamber 66 through the inlet port 84. This fluid is discharged from the pump chamber through the pump discharge port 86, the discharge passage 92, and past the needle valve 98 into the reservoir.

3

Means are provided for establishing a one-way connection between the drum 46 and the rotary pump element 68. This means is illustrated in Figures 2 and 5 as comprising a clutch extension 100 provided on the drum 46. The shaft 78 has connected thereto an enlarged element 102 located within the clutch extension 100 and a suitable one-way or over-running type clutch mechanism is provided. As illustrated in Figure 5, this over-running clutch may include tapered recesses 104 provided circumferentially of the element 102 which receive balls 106 adapted to be wedged between the recesses 104 and the inner surface of the clutch extension 100 when the element 102 is rotated in a counterclockwise direction as seen in Figure 5.

From the foregoing it will be observed that when the user pulls the handle 42 toward the seat, the belt 44 is unwound from the drum 46, thereby tensioning the spring 58. This same motion however couples the drum to the rotary pump element 68 and rotation of the pump element forces hydraulic fluid through the pump and past the variable restriction afforded by the needle valve 98. Accordingly, resistance to rearward movement of the handle 42 is controlled by appropriate adjustment of the needle valve. On the recovery stroke, the over-running clutch disengages and the drum 46 is rotated by the spring 58 to rewind the belt 44 on the drum.

There is thus provided a rowing machine in which the resistance to the rowing stroke may be uniform throughout and of controlled degree. Moreover, on the recovery stroke the belt may be rewound automatically by the spring 58 and under a tension controlled by such spring.

The pump is entirely self-contained and is adapted to withdraw fluid from the reservoir and return fluid to the reservoir through passages which are formed internally in the pump casing. The drum is mounted directly on a hub extending outwardly from the pump casing and concentric with the axis of rotation of the rotary pump element, and the drum includes a clutch extension which is likewise coaxial with the axis of rotation of the pump element and drum. The construction is thereby greatly simplified and lends itself particularly well to the production of an article of attractive appearance which is completely devoid of external conduits, valves, piping or the like. Furthermore, as a result of this construction damage to externally exposed piping or conduits is avoided.

The drawings and the foregoing specification constitute a description of the improved rowing machine in such full, clear, concise and exact terms as to enable any person skilled in the art to practice the invention, the scope of which is indicated by the appended claims.

What I claim as my invention is:

1. A rowing machine comprising a track, a seat movable along said track, a drum mounted adjacent one end of said track, a flexible belt wound around said drum, a handle on the free end of said belt, a pump having a rotary element, a reservoir for said pump, said pump having inlet and discharge passages connected to said reservoir, an adjustable restriction valve in said discharge passage, a one-way clutch connecting said drum and rotary element and effective to couple said drum to said element when said belt is withdrawn from said drum, and resilient means operatively connected to said drum to urge said drum for rotation in a direction to wind said belt on said drum.

2. A rowing machine comprising a frame including a pair of spaced parallel rails, a seat mounted for movement along said rails, a foot rest carried by said frame forwardly of said seat, oar simulating mechanism carried by said frame forwardly of said foot rest and including a drum mounted midway between an extension of said rails, a belt wound upon said drum, adjustable pump mechanism operatively connected to said drum opposing unwinding of said belt from said drum, and spring means

4

operatively connected to said drum for rotating said drum in a direction to wind said belt thereon.

3. A machine as defined in claim 2 which comprises a one-way clutch connecting said pump mechanism to said drum to provide for actuation of said pump only when said belt is withdrawn from said drum.

4. In a rowing machine, a pump casing having a pump chamber and a reservoir formed therein, inlet and discharge passages within said casing connecting said chamber and reservoir, a rotary pump element in said chamber, a hub on said casing extending outwardly from said chamber, a drum mounted for rotation on said hub and defining therewith an annular space, a coil spring in said space connected at its ends to said hub and drum, said drum having a clutch housing of circular cross-section disposed in alignment with said hub, a shaft connected to said rotary pump element and extending through said hub into said clutch housing, and clutch means connecting said clutch housing and said shaft for one-way driving connection.

5. Apparatus as defined in claim 4 which comprises a belt wound upon said drum, and a handle secured to the outer end of said belt.

6. A rowing machine comprising a pair of parallel rails interconnected at the front and rear ends thereof with cross pieces provided with depending supporting legs, a seat carried by said rails for sliding movement longitudinally thereof, said machine comprising a forward portion including a pair of frame elements constituting longitudinal extensions of said rails and having their rear ends detachably connected to the cross piece provided at the front end of said rails, a foot rest interconnecting said frame elements intermediate the ends thereof, a cross piece interconnecting the forward end of said frame elements and including depending supporting legs, and oar simulating mechanism carried by said frame elements and including a drum having a flexible belt wound thereon, a handle on the free end of said belt, and pump mechanism for opposing rotation of said drum in a direction resulting from unwinding of said belt from said drum.

7. A machine as defined in claim 6 in which said seat includes means surrounding said rails to prevent separation of said seat therefrom.

8. A machine as defined in claim 6 in which said oar simulating mechanism includes adjustable means for opposing flow of fluid through said pump mechanism.

9. A machine as defined in claim 8 comprising an over-running clutch for connecting said drum to said pump mechanism only when said drum is rotated by withdrawal of said belt therefrom.

10. A machine as defined in claim 9 in which said drum is provided with resilient means tending to rotate said drum in a direction to wind said belt thereon.

11. A rowing machine comprising a frame including a pair of spaced parallel rails, a seat mounted for movement along said rails, a foot rest carried by said frame forwardly of said seat, oar simulating mechanism carried by said frame forwardly of said seat and including a pump casing having a pump chamber and a reservoir formed therein, inlet and discharge passages connecting said chamber and reservoir, a rotary pump element in said chamber, a hub on said casing extending outwardly from said chamber, a drum mounted for rotation on said hub and defining therewith an annular space, a flexible belt wound upon said drum, a handle on the free end of said belt, a coil spring in said annular space connected at its ends to said hub and drum and operative to rotate said drum in a direction to wind said belt thereon, said drum having a clutch housing of circular cross-section in alignment with said hub, a shaft connected to said pump element and extending through said hub into said clutch housing, and a one-way driving connection between said housing and shaft and effective to couple said shaft to said housing only when said drum is rotated in a direction to withdraw said belt from said drum.

2,725,231

5

12. A rowing machine as defined in claim 11 including an adjustable restriction valve in said discharge passage.

1,782,728
1,950,896
1,974,445
2,042,764
5 2,475,667

References Cited in the file of this patent

UNITED STATES PATENTS

445,726 Coop ----- Feb. 3, 1891

6

Kiefer ----- Nov. 25, 1930
Luzzi ----- Mar. 13, 1934
Calleson ----- Sept. 25, 1934
Birch ----- June 2, 1936
Jackson ----- July 12, 1949