



## INTERNATIONAL APPLICATION PUBLISHED UNDER THE PATENT COOPERATION TREATY (PCT)

<p>(51) International Patent Classification <sup>5</sup> : C12N 5/00, A61L 27/00</p>	<p>A1</p>	<p>(11) International Publication Number: <b>WO 91/19783</b> (43) International Publication Date: 26 December 1991 (26.12.91)</p>
<p>(21) International Application Number: PCT/US91/03905 (22) International Filing Date: 7 June 1991 (07.06.91) (30) Priority data: 538,869 15 June 1990 (15.06.90) US (71) Applicant: E.I. DU PONT DE NEMOURS AND COMPANY [US/US]; 1007 Market Street, Wilmington, DE 19898 (US). (72) Inventors: HAYNIE, Sharon, Loretta ; 963 North Randolph Street, Philadelphia, PA 19123 (US). LAWSON, James, Robert ; 10 Hickory Lane, Marietta, OH 45750 (US). WATT, Teresa, Stoesser ; 112 Warwick Drive, Wilmington, DE 19803 (US).</p>		<p>(74) Agents: HAMBY, William, H. et al.; E.I. du Pont de Nemours and Company, Legal/Patent Records Center, 1007 Market Street, Wilmington, DE 19898 (US). (81) Designated States: AT (European patent), BE (European patent), CA, CH (European patent), DE (European patent), DK (European patent), ES (European patent), FR (European patent), GB (European patent), GR (European patent), IT (European patent), JP, LU (European patent), NL (European patent), SE (European patent).  <b>Published</b> <i>With international search report.</i></p>
<p>(54) Title: ELASTOMERIC POLYMER SURFACES THAT SUPPORT MAMMALIAN CELLS AND PROCESSES FOR THE PREPARATION THEREOF</p> <p>(57) Abstract</p> <p>Polymeric substrates are disclosed having cells attached thereto, wherein the substrate comprises a copolymer of repeating units of a soft segment having carbon and oxygen in a ratio of from 2.6 to 4.5 and of repeating units of a crystallizable hard segment. Shaped articles of the substrates and methods of preparation are also disclosed.</p>		

**FOR THE PURPOSES OF INFORMATION ONLY**

Codes used to identify States party to the PCT on the front pages of pamphlets publishing international applications under the PCT.

<b>AT</b>	Austria	<b>ES</b>	Spain	<b>MG</b>	Madagascar
<b>AU</b>	Australia	<b>FI</b>	Finland	<b>ML</b>	Mali
<b>BB</b>	Barbados	<b>FR</b>	France	<b>MN</b>	Mongolia
<b>BE</b>	Belgium	<b>GA</b>	Gabon	<b>MR</b>	Mauritania
<b>BF</b>	Burkina Faso	<b>GB</b>	United Kingdom	<b>MW</b>	Malawi
<b>BG</b>	Bulgaria	<b>GN</b>	Guinea	<b>NL</b>	Netherlands
<b>BJ</b>	Benin	<b>GR</b>	Greece	<b>NO</b>	Norway
<b>BR</b>	Brazil	<b>HU</b>	Hungary	<b>PL</b>	Poland
<b>CA</b>	Canada	<b>IT</b>	Italy	<b>RO</b>	Romania
<b>CF</b>	Central African Republic	<b>JP</b>	Japan	<b>SD</b>	Sudan
<b>CG</b>	Congo	<b>KP</b>	Democratic People's Republic of Korea	<b>SE</b>	Sweden
<b>CH</b>	Switzerland			<b>SN</b>	Senegal
<b>CI</b>	Côte d'Ivoire	<b>KR</b>	Republic of Korea	<b>SU</b>	Soviet Union
<b>CM</b>	Cameroon	<b>LI</b>	Liechtenstein	<b>TD</b>	Chad
<b>CS</b>	Czechoslovakia	<b>LK</b>	Sri Lanka	<b>TG</b>	Togo
<b>DE</b>	Germany	<b>LU</b>	Luxembourg	<b>US</b>	United States of America
<b>DK</b>	Denmark	<b>MC</b>	Monaco		

TITLE

ELASTOMERIC POLYMER SURFACES THAT SUPPORT  
MAMMALIAN CELLS AND PROCESSES FOR THE  
PREPARATION THEREOF

5

FIELD OF THE INVENTION

The present invention relates to elastomeric polymeric surfaces that provide for the attachment, growth and adhesion of mammalian cells without pretreating the surfaces, as well as processes for the preparation of these surfaces. More particularly, the present invention relates to polymeric substrates of select copolymers useful as vascular grafts, and methods for preparing the fibers used therein.

10  
15BACKGROUND OF THE INVENTION

There are a variety of references that are directed to vessels and synthetic surfaces designed to accommodate cell growth. For example, U.S. 4,546,083 is directed to a cell culture device for the cultivation of animal, plant, microbiological or artificial cells. The device involves an arrangement of fibers within a housing which provides for a continuous flow of nutrient fluid through the housing. The fibers are coated by covalent or noncovalent adsorptive attachment with any desired cells to be grown in culture. Generally, any fiber-forming material which is capable by itself or through further treatment of adsorbing viable cells on its surface can be utilized. One category of fibers is identified as heterochain synthetic polymers and includes polyesters. The reference further indicates that the fibers may be used as such or pretreated by physical or chemical methods. However, the reference concentrates on the attachment of cells to fibers by introducing certain growth media or pretreating agents.

20  
25  
30

It only generalizes to the study of cell growth on fibers without pretreatment.

U.S. 4,804,381 concerns an artificial vessel made of a microporous membrane having pores which are filled with a permeable gel or which are closed over by a thin porous layer. A monolayer of endothelial cells is provided on the internal surface and smooth muscle cells are layered on the outer surface. The membrane pores are large enough to disrupt the growth of endothelial cells over them, and thus the gel or the thin porous layer smooths the surface of the membrane on the inside. The endothelial cells grow to form a closed continuous monolayer. However, the artificial vessel according to the reference requires the gel or the thin porous layer together with the membrane.

International Application No. PCT/AU88/00368 relates to the use of a copolymer of perfluoro-3,6-dioxa-4-methyl-7-octene sulfonyl fluoride and a monomer, as a surface for the attachment and growth of adherent animal cells. The copolymer is cited as having particular application to the manufacture and use of prosthetic vascular grafts, connective tissue replacements and soft tissue replacements that incorporate such a copolymer. In accordance with one embodiment of the reference, the copolymeric surface is provided for the attachment and growth of adhesive serum proteins, forming a copolymer-protein complex. These surfaces are further exposed to cells, whereupon the cells adhere to the surface. However, a preferred embodiment of the reference involves the use of NAFION® (a trademark of E. I. du Pont de Nemours and Company, Inc.) (a copolymer of tetrafluoroethylene and adhesive proteins) with the copolymer of sulfonyl fluoride and a monomer.

An article by Greisler et al., entitled "Hemodynamic Effects on Endothelial Cell Monolayer Detachment from Vascular Protheses" (Arch Surg., Vol. 124, April, 1989) evaluates the adherence of endothelial cells that were cultured on fibronectin-treated prosthetic materials that were perfused in vitro under different pulsatile hemodynamic conditions. The results of the study confirm that canine jugular vein endothelial cells, grown to confluence on fibronectin-coated polyester elastomer small-diameter vascular prostheses, will be retained at 90% confluence by that surface following two hours of perfusion under two extremes of physiological hemodynamic parameters. An article by Kesler et al., entitled "Sequential Inoculation for Optimal Cell Distribution on Tubular Grafts" (Endothelial Seeding in Vascular Surgery, 1987) undertook a series of experiments to explore problems associated with cell distribution. Expanded polytetrafluoroethylene and polyester elastomer grafts were coated with fibronectin and subjected to inoculation density experiments. It was concluded that sequential inoculation optimized total cell attachment and provided a uniform distribution of cells on the inside surfaces of tubular grafts of expanded polytetrafluoroethylene and polyester elastomer that have been coated with fibronectin substrate. However, the materials of both of these articles required treatment with fibronectin to promote the adherence of endothelial cells.

It is an object of the present invention to provide a polymeric substrate that enables cells to attach and grow thereon, without the requirement of any substrate surface pretreatment. It is a further object of the present invention to provide a multitude of shaped articles of this polymeric substrate, including vascular

grafts. A feature of the present invention is the ability of the polymeric substrate to retain cells securedly even at relatively high flow rates and pulsatile pressures encountered in vivo with vascular  
5 grafts, and further that the cells are functional. It is another feature of the present invention to provide polymeric substrates having the aforementioned properties and including a wide variety of copolymeric components. It is particularly advantageous of the  
10 present invention that a broad selection of cells may be used in conjunction with the polymeric substrates. A further advantage of the presently disclosed polymeric substrates is that the substrate surface may be formed in a variety of textures and porosities.

15 These and other objects, features and advantages of the present invention will become readily understood upon having reference to the following description of the invention.

#### SUMMARY OF THE INVENTION

20 The present invention is directed to a polymeric substrate having cells attached thereto, said substrate comprising a copolymer of repeating units of a soft segment having carbon and oxygen in a ratio of from 2.6 to 4.5 and of repeating units of a crystallizable hard  
25 segment.

In a preferred embodiment the soft segment is poly(tetramethylene ether glycol).

In another preferred embodiment the crystallizable hard segment is poly(butylene terephthalate). In this  
30 embodiment it is still further preferred that the copolymer contains from about 18 to about 77 weight percent (most preferred from about 65 to about 77 weight percent) of repeating units of the soft segment, and from about 23 to about 82 weight percent (most preferred

from about 23 to about 35 weight percent) of repeating units of the crystallizable hard segment.

In another preferred embodiment the crystallizable hard segment is the reaction product of ethylene diamine with methylene bis(4,4'-diphenylisocyanate). In this embodiment it is still further preferred that the copolymer contains from about 85 to about 95 weight percent (most preferred from about 85 to about 90 weight percent) of repeating units of the soft segment, and from about 5 to about 15 weight percent (most preferred from about 10 to about 15 weight percent) of repeating units of the crystallizable hard segment.

The cells are selected from the group consisting of fibroblasts, adipose cells, endothelial cells, epithelial cells, organ parenchymal cells, muscle cells, nerve cells, cartilage cells, bone cells and mixtures thereof.

The present invention further encompasses shaped articles comprising the above described polymeric substrate and having cells attached thereto. A preferred article according to the invention is shaped as a vascular graft and connecting a vessel to another portion thereof or to another vessel. The article comprises a polymeric substrate having an interior surface and an exterior surface, the interior surface defining an aperture therethrough and having cells attached thereto. The substrate comprises a copolymer of repeating units of a soft segment having a carbon and oxygen ratio of from 2.6 to 4.5 and of repeating units of a crystallizable hard segment.

The present invention also includes various methods for the preparation of shaped articles of the invention. One such method is for the preparation of shaped articles comprising a polymeric substrate having cells attached thereto, said substrate comprising a copolymer

of repeating units of a soft segment having carbon and oxygen in a ratio of from 2.6 to 4.5 and of repeating units of a crystallizable hard segment. The method comprises:

- 5                   shaping said polymeric substrate into the desired shaped article; and  
                  attaching said cells to said polymeric substrate.

#### BRIEF DESCRIPTION OF THE FIGURES

10           Figure 1 is a plot of total cell response as a function of the carbon to oxygen ratio in polyester segments of polymeric substrates according to the invention.

                  Figure 2 is an illustration of the ex vivo shunt  
15           apparatus used in examples herein.

                  Figure 3 is a series of photomicrographs illustrating blood clot formation for various polymeric surfaces.

#### DETAILED DESCRIPTION OF THE INVENTION

20           The polymeric substrates of the present invention are adaptable to a wide variety of biological and physical applications. In general, these substrates find utility in any environment wherein natural or artificial vessels, tissues, organs and the like are to  
25           be joined together. Thus the present polymeric substrates are useful for the support and functioning of mammalian cells. Exemplary of such uses but without intending to limit the generality of the foregoing are vascular grafts, arterio-venous fistulae, artificial  
30           hearts, heart valves, aneurysm repair, ventricular assist devices, and cardiac patches, support for artificial organs such as pancreas and bone marrow and other cellular therapy devices and tissue cultures.

                  The polymeric substrates may also be used to  
35           introduce artificial pancreas, artificial liver or other



artificial organs into a biological system. These substrates may also serve as bone marrow cell growth, nerve cell growth, cells from other tissues, and the like. The polymeric substrates also find utility with respect to specific depletion therapy, transgenic cell approaches, cell-drug delivery systems, and in vitro cell culture devices.

The polymeric substrates developed as vascular grafts are considered to be particularly useful in blood vessel bypass procedures, wherein the graft connects an artery to another portion thereof or to another artery. Another utility of these polymeric substrates is to enhance peripheral circulation and wherein the graft connects a blood vessel to another portion thereof or to another blood vessel.

Focusing our attention with more particularity on the polymeric substrate, it is preferable that the crystallizable hard segment be an aromatic diacid. Moreover, the preferred carbon to oxygen ratio of the soft segment is from 4.0 to 4.3.

The surface characteristics of the polymeric substrate affect the attachment, growth and securedness of the various cells supported by the substrate. For example, if the substrate surface texture is rough (defined generally as having a variety of indentations and other features so that it is not topically uniplanar) the cells are not afforded a suitable base to promote desirable attachment to the surface. In particular, the texture with such features in the range of about 0.1 to 50  $\mu\text{m}$  is detrimental to endothelial cell attachment and growth. However and preferably if the substrate surface is smooth in texture, the various cells generally attach to the surface; further the cells are capable of growth on a smooth surface and are secured to the surface sufficiently to withstand certain

levels of flow rate and pressures of fluids that move relative to the cells in situ. These cells may function to prevent blood clotting.

Another parameter affecting cell attachment and  
5 growth is the porosity of the surface of the polymeric substrate. At one extreme, the surface may have no porosity; that is, the surface has no apertures of any type therein. A nonporous surface promotes adhesion, growth and attachment of the cells, and it is a  
10 requirement for shaped articles that must insulate the flow of fluids (i.e., no exchange of materials across the polymeric substrate). At the other extreme, a surface with very large pores is not a suitable substrate for the attachment and support of cells. However, there is  
15 a range of pore size of the surface that is suitable for cell attachment while simultaneously providing a means for the exchange of fluids through the substrate. Typically the useful range of porosity of this invention is from 0.01 to 10  $\mu\text{m}$ .

20 Of the great variety of cells useful with the present invention (classified as mammalian cells), most preferred are endothelial cells. Moreover, while a unique and distinguishable feature of the present invention is the lack of any requirement to pretreat the  
25 polymeric substrate in order to foster cellular attachment and growth thereon, such pretreatment is not detrimental to the substrate. Accordingly, the substrate may further comprise an adsorption promoting layer of chemical compound interposed between the  
30 substrate and the cells.

The variety of shaped articles contemplated according to the invention (several of which were mentioned earlier) may be formed from the copolymeric soft and hard segments reviewed previously. Thus, the  
35 shaped article may be formed with a soft segment of

poly(tetramethylene ether glycol). Further the crystallizable hard segment used to form the shaped article may be selected from either poly(butylene terephthalate) or alternatively the reaction product of ethylene diamine with bis(4,4'-diphenylisocyanate). These articles may further employ aliphatic diacids for the hard segment.

The polymeric substrates can be fabricated in a variety of shapes, including flat, tubular, fiber and bead. Hence, the variety of shapes herein is expressed in general terms as planar, cylindrical and spherical. Generally the surface diameter should be at least about twice the diameter of the spread cell being deposited.

A preferred shaped article is the aforementioned vascular graft. Particularly preferred in a vascular graft constructed of a soft segment of poly(tetramethylene ether glycol) and a crystallizable hard segment of poly(butylene terephthalate) or alternatively the reaction product of ethylene diamine with methylene bis(4,4'-diphenylisocyanate). The vascular graft of the present invention is particularly attractive when the inner surface of the graft is lined with endothelial cells. In tests, these cells remained secured to the graft as fluid passes through the graft, at flow rates of up to 200 ml/min and pulsatile pressures of up to 150 over 80 mm Hg.

Further contemplated as within the scope of the invention are methods for the preparation of shaped articles comprising the polymeric substrate, and one such method was reviewed previously. This method may be further enhanced by attaching the cells to the substrate by seeding techniques as is readily understood and appreciated by those skilled in the art. Alternatively, the cells may be grown in a culture medium or obtained from a tissue source prior to seeding to the polymeric

substrate, techniques also well developed in the relevant literature.

A method considered particularly useful in preparing vascular grafts according to the invention is disclosed and claimed herein. The method comprises shaping the polymeric substrate into a shaped article (preferably a fiber) having an interior surface and an exterior surface, with the interior surface defining an aperture therethrough. Cells are introduced into the interior surface of the fiber. Unattached cells are removed from the interior surface thereof, and the article is placed in a suitable growth medium under conditions sufficient to allow the cells to grow to a desired density along the interior surface thereof.

Central to the instantly claimed polymeric substrates is the ratio of carbon to oxygen in the copolymer soft segment. As revealed in Figure 1, the total cell response (considered as attachment and growth of the cells) increases as the ratio of carbon to oxygen is increased wherein the soft segment is polyester. Thus, for this system only approximately 10 percent of the endothelial cells brought into contact with the polymeric substrate containing a polyester soft segment attached to the substrate and exhibited growth thereon, where the carbon to oxygen ratio is about 2.4. There is compared to a similar substrate wherein the carbon to oxygen ratio is about 4.3, wherein approximately 70 percent of the endothelial cells exhibited attachment and growth.

The selection of poly(tetramethylene ether glycol) soft segment and poly(butylene terephthalate) hard segment for the polymeric substrate is one of a family of thermoplastic copolyester elastomers considered useful for the present invention.

According to this invention there is provided a thermoplastic copolyester elastomer consisting essentially of a multiplicity of recurring intralinear long chain and short chain ester units connected head-to-tail through ester linkages, said long chain ester units being represented by the following structure:



and said short chain ester units being represented by the following structure:



20 wherein:

G is a divalent radical remaining after removal of terminal hydroxyl groups from poly(alkylene oxide) glycols having a carbon to oxygen ratio of about 2.5-4.3, a molecular weight above about 400 and a melting point below about 60°C;

25 R and R<sup>1</sup> are divalent radicals remaining after removal of carboxyl groups from dicarboxylic acids having molecular weights less than about 300; and

30 D is a divalent radical remaining after removal of hydroxyl groups from a low molecular weight diol having a molecular weight less than about 250;

35

with the provisos that the short chain ester units constitute about 23-82% by weight of the copolyester, at least about 80% of the R groups must be 1,4-phenylene radicals, at least about 80% of the D groups must be  
5 1,4-butylene radicals, and the sum of the percentages of the R groups which are not 1,4-phenylene radicals and of the D groups which are not 1,4-butylene radicals cannot exceed about 20%.

The term "long chain ester units" as applied to  
10 units in a polymer chain refers to the reaction product of a long chain glycol with a dicarboxylic acid. Such "long chain ester units", which are a repeating unit in the copolyesters of this invention, correspond to the Formula (a) above. The long chain glycols are polymeric  
15 glycols having terminal (or as nearly terminal as possible) hydroxy groups and a molecular weight above about 400 and preferably from about 400-4000. The long chain glycols used to prepare the copolyesters of this invention are poly(alkylene oxide) glycols having a  
20 carbon to oxygen ratio of about 2.5-4.3. Representative long chain glycols are poly(1,2- and 1,3-propylene oxide) glycol, poly(tetramethylene oxide) glycol, random or block copolymers of ethylene oxide and 1,2-propylene oxide (used in proportions such that the carbon to  
25 oxygen mole ratio in the glycol exceeds 2.5) and random or block copolymers of tetrahydrofuran with minor amounts of a second monomer such as methyltetrahydrofuran (used in proportions such that the carbon to oxygen mole ratio on the glycol does not exceed about  
30 4.3).

The term "short chain ester units" as applied to units in a polymer chain refers to low molecular weight compounds of polymer chain units having molecular weights less than about 550. They are made by reacting  
35 a low molecular weight diol (below about 250) with a

dicarboxylic acid to form ester units represented by Formula (b) above.

Useful polymers having a poly(tetramethylene ether glycol) soft segment and a hard segment of poly(butylene terephthalate) are described in U.S. Patent 4,906,729 which is incorporated by reference herein. It is to be understood that in selecting a polymer according to the reference or otherwise according to the invention, the polymer must be substantially free of contaminants and impurities. For example, the polymers must be substantially free of silicon. This is not to say that additives cannot be incorporated into the polymer; depending on the desired properties certain additives may be appropriate for addition. Rather, and as is understood by those skilled in the art, these polymers must be biocompatible and accordingly types of additives and levels of impurities must be carefully controlled.

It is essential that at least about 80 mole percent of the dicarboxylic acid incorporated into the polymer be terephthalic acid and at least about 80 mole percent of the low molecular weight diol incorporated into the polymer be 1,4-butanediol. Thus, at least 80% of the R groups in Formulae a and b above are 1,4-phenylene radicals and at least about 80% and the D groups in Formula b above are 1,4-butylene radicals. A further requirement in making the polymers of this invention is that the sum of the percentages of the R groups which are not 1,4-phenylene radicals and the D groups which are not 1,4-butylene radicals cannot exceed about 20%. For example, if 20% of the low molecular weight diol molecules used are other than 1,4-butanediol, then all of the dicarboxylic acid used must be terephthalic acid, or if 10% of the low molecular weight diol molecules used are other than 1,4-butanediol, then at least about 90% of the dicarboxylic acid must be terephthalic acid.

Copolyesters having fewer 1,4-butylene terephthalate units than is assured by the foregoing proportions do not have sufficiently rapid hardening rates. The D and R units which are not 1,4-butylene and 1,4-phenylene, respectively, can be derived from any of the low molecular weight diols or dicarboxylic acids named above.

The copolyesters of this invention contain about 23-82% by weight of short chain ester units corresponding to Formula (b) above, the remainder being long chain ester units corresponding to Formula (a) above. When the copolyesters contain less than about 48% by weight short chain units, the tear strength and solvent resistance of the copolyesters fall to undesirably low levels and when the copolyesters contain more than about 65% short chain units, the low temperature properties worsen and the copolyesters become less elastomeric. The optimum balance of properties is obtained when the short chain ester content is about 23-35%.

The preferred copolyesters of this invention are those prepared from dimethylterephthalate, 1,4-butanediol and poly(tetramethylene oxide) glycol having a molecular weight from about 600-2000.

The polymers described herein can be made conveniently by a conventional ester interchange reaction.

The selection of poly(tetramethylene ether glycol) soft segment together with the reaction product of ethylene diamine with methylene bis(4,4'-diphenylisocyanate) as the hard segment is one of a family of polymers considered useful for the present invention.

There are long chain synthetic polymers that comprise at least 85% by weight segmented polyurethane. The terms "soft segment" and "hard segment" refer to



specific portions of the polymer chains. The soft segments are the polyester portions of the segmented polyurethane and polymer and the hard segments refer to the portions of the polymer chains that are derived from the reaction of an organic diisocyanate with a diamine chain extender. Glycol acidity, as used herein, refers to end groups, such as acid end groups, of the polyester glycol precursor which do not react with organic diisocyanates under conventional urethane-forming conditions, such as those illustrated in the examples below. The isocyanate end group content of a polymer may be referred to as the NCO content.

Useful polymers having a poly(tetramethylene ether glycol) soft segment and a hard segment of the reaction product of ethylene diamine with methylene bis(4-4'-diphenylisocyanate), are described in U.S. Patents 4,296,174 and 3,428,711 which are incorporated by reference herein. It is to be understood that in selecting a polymer according to these references or otherwise according to the invention, the polymer must be substantially free of contaminants and impurities. For example, the polymers must be substantially free of silicon. This is not to say that additives cannot be incorporated into the polymer; depending on the desired properties certain additives may be appropriate for addition. Rather, and as is understood by those skilled in the art, these polymers must be biocompatible and accordingly types of additives and levels of impurities must be carefully controlled.

The segmented polyurethanes contain the recurring linkage  $-O-CO-NH-$ . A substantial number of the urethane nitrogens may be joined to radicals, usually aromatic, which are further attached to a ureylene residue  $-NH-CO-NH-$ . Generally speaking, these segmented polyurethanes are prepared from hydroxyl-terminated

prepolymers such as hydroxyl-terminated polyethers of low molecular weight. Reaction of the prepolymer with a stoichiometric excess of organic diisocyanate, preferably an aromatic diisocyanate, produces an  
5 isocyanate-terminated polymeric intermediate, which may then be chain-extended with a difunctional, active hydrogen-containing compound, such as water, hydrazine, organic diamines, glycols, dihydrazides, amino-alcohols, etc.

10 From a standpoint of commercial availability, the preferred hydroxyl-terminated prepolymers are the polyether glycols, and random or blocked copolymers of tetrahydrofuran with minor amounts of a second monomer such as methyl tetrahydrofuran. For the purposes of  
15 this invention, the preferred polyether glycols include polytetramethylene ether glycol and glycols of polytetramethylene ether having urethane groups in the polymer chain.

The hydroxyl-terminated soft segment is generally  
20 reacted with an organic diisocyanate which is preferably an aromatic diisocyanate, as indicated hereinabove. Suitable aromatic diisocyanates include p-phenylene diisocyanate, 4,4'-biphenylene diisocyanate, p,p'-methylenediphenyl diisocyanate, and p,p'-isopropyl-  
25 idenediphenyl diisocyanate. Aliphatic and cycloaliphatic diisocyanates, for example, 4,4'-methylenedicyclohexyl diisocyanate, are also suitable. The diisocyanates may contain other substituents, although those which are free from reactive groups other  
30 than the two isocyanate groups, are ordinarily preferred. The organic diisocyanate is not critical for this invention.

The difunctional, active hydrogen-containing compounds suitable as chain-extenders include a wide  
35 variety of compounds, as indicated hereinabove. Organic

diamines are preferred. Suitable diamines include ethylenediamine, tetramethylenediamine, 1,2-propylenediamine, m-xylylenediamine, p-xylylenediamine, cyclohexylenediamine, piperazine, and many others.

- 5 Symmetrical aliphatic diamines are preferred, but aromatic diamines, e.g., p-phenylenediamine and p,p'-methylenedianiline, may be used.

It should be noted that it is not desirable to incorporate polyester soft segments into the  
10 polyurethane-based polymer. Additionally and as pertaining to copolymers wherein the soft segment is poly(tetramethylene ether glycol) and the hard segment is either poly(butylene terephthalate) or the reaction product of ethylene diamine with methylene bis(4,4'-  
15 diphenylisocyanate), it is notable that these copolymers may be used as elastomeric matrices.

The invention will be more readily understood and appreciated upon having reference to the examples herein.

20

#### EXAMPLES

##### Procedures

###### A. Collection and Maintenance of Cells

Pure cultures of endothelial cells are obtained from excized canine jugular veins by either  
25 gently scraping the lumen of the vein with a scalpel, or by everting the blood vessel onto a glass rod and enzymatically treating the lumen of the vessel to remove the cells as commonly described in the literature. Once removed from the lumen of the blood vessel, the cells  
30 are grown in culture media suitable for endothelial cells supplemented with 10% fetal calf serum and 2.5% endothelial cell growth supplement. Cells are maintained in culture for three to five passages before use.

Polymer membranes of the examples are cut into discs (13 mm in diameter), sterilized and placed into wells of a standard 24-well tissue culture dish. Samples are tightly secured to the bottom of the well by  
5 insertion of a thin, non-toxic gasket at the circumference of the well. All samples are run in triplicate and average attachment and growth results tabulated.

#### B. Attachment Assay

10 To determine the ability of various surfaces to support cell attachment, endothelial cells are labeled with the radioisotope  $^{51}\text{Chromium}$  ( $50 \mu\text{Ci/ml}$  of growth media). After 12 hours, unincorporated label is washed away and  $2.3 \times 10^3$  labeled cells are added to  
15 wells containing the polymer surfaces. Assay plates are placed into incubators for one hour to allow cells to attach to the surfaces. After one hour unattached cells are washed away and counts remaining attached to the polymer surfaces are determined using a Beckman gamma-  
20 well counter.

#### C. Growth Assay

To determine the ability of various surfaces to support cell growth, endothelial cells are allowed to attach to polymer surfaces as described above. After  
25 one hour unattached cells are removed, growth medium is replaced and the cells are returned to the incubator for 48 hours to allow time for cell growth and replication. After 36 hours, cell growth medium is replaced with fresh medium containing  $0.5 \mu\text{Ci/ml}$   $^3\text{H-Thymidine}$ . After  
30 12 hours of cell growth in labeling medium, the cells are washed of free label, DNA is purified from each sample and counts incorporated into DNA are determined.

#### D. Seeding and Growth of Cells on Polymers in Tubular Configuration

Polymers in tubular configuration are plugged on one end. Cells in growth medium are then added to the lumen of the tube at a final concentration of  $2 \times 10^5$  cells/cm<sup>2</sup>. The open end of the tubing is then plugged and the tubing is rotated at 1 rpm for two hours while cells are attaching. After two hours, tubing samples are unplugged, rinsed free of unattached cells and placed in growth medium for 48 hours. In order to visualize, cells are stained with Hematoxylin.

#### E. Preparation of Segmented Thermoplastic Copolyester Elastomer

A catalyst is prepared by dissolving 111.05 ml of tetrabutyl titanate in 900 ml of dry butanol-1 to form a solution. A second solution is prepared by dissolving 3 g of anhydrous magnesium acetate in 100 ml of dry methanol. Two parts by volume of the first solution is mixed with 1 part by volume of the second solution, resulting in catalyst.

The following materials are placed in a 500 ml flask fitted for distillation:

	g.
Polytetramethyleneether glycol;	
number average molecular weight	
about 975	385
1,4-butanediol	365
Dimethyl terephthalate	600
Sym-dibeta-naphthyl-p-phenylene-	
diamine	2.98

A stainless steel stirrer with a paddle cut to conform with the internal radius of the flask is positioned about 1/8" from the bottom of the flask and agitation is started. The flask is placed in an oil bath at 160°C, agitated for five minutes and then 7.1 ml

of the catalyst is added. Methanol distills from the reaction mixture as the temperature is slowly raised to 250°C over a period of one hour. When the temperature reaches 250°C, the pressure is gradually reduced to  
5 0.3 mm, Hg within 20 minutes. The polymerization mass is agitated at 250°C/0.3 mm, Hg for 90 minutes. The resulting viscous molten product is scraped from the flask in a nitrogen (water and oxygen free) atmosphere and allowed to cool. The inherent viscosity of the  
10 product at a concentration of 0.1 g/dl. in m-cresol at 30°C is 1.65. Samples for physical testing are prepared by melt pressing discs according to procedures well known to those skilled in the art, resulting in samples of polyester elastomer.

15 COMPARATIVE EXAMPLE 1

Samples of tissue culture grade polystyrene manufactured by Costar Corporation were obtained. These samples have been pretreated by the manufacturer to promote cell attachment and growth.

20 Canine endothelial cells at passage number four were used with the polystyrene surfaces in conjunction with the attachment and growth assays. Attachment results (cpm <sup>51</sup>chromium) were determined as 16,953 (± 44) and 91 percent of the total cells attached. Growth  
25 results (cpm <sup>3</sup>H-Thymidine) were determined as 54,132 (± 3,167) and 100 percent of the total cells exhibited growth.

COMPARATIVE EXAMPLE 2

30 Samples of polytetrafluoroethylene manufactured by the Du Pont Company were obtained. The samples were formed into disks according to the procedure recited previously. The disks were not pretreated.

Canine endothelial cells at passage number four were used with the polytetrafluoroethylene disks in  
35 conjunction with the attachment and growth assays..

Attachment results (cpm  $^{51}$ chromium) were determined as 4,550 ( $\pm$  726) and 39 percent of the total cells attached. Growth results (cpm  $^3$ H-Thymidine) were determined as 14,572 ( $\pm$  392) and 26 percent of the total cells exhibited growth.

#### EXAMPLE 1

Disks of polyester elastomer prepared under (E) of the procedures discussion were used with the canine endothelial cells at passage number four in conjunction with the attachment and growth assays. The disks were not pretreated. Attachment results (cpm  $^{51}$ chromium) were determined as 14,810 ( $\pm$  1,774) and 90 percent of the total cells attached. Growth results (cpm  $^3$ H-Thymidine) were determined as 41,125 ( $\pm$  1,578) and 75 percent of the total cells exhibited growth.

It is seen that polymeric substrates according to the invention compare favorably to pretreated polystyrene and further are superior to unpretreated polytetrafluoroethylene.

#### COMPARATIVE EXAMPLE 3

To assess the cell strength of attachment and function on untreated polymer surfaces, the apparatus according to Figure 2 was used in canine femoral ex vivo shunt. In the figure, the apparatus is shown generally at 10. Tubes of experimental material 12 (a polyester elastomer) are connected to catheters 14 and a silastic tubing 16 by polytetrafluoroethylene connectors 18 and silastic connectors 20 as shown. The canine subject is injected with 100 IU Heparin/kg, and the femoral artery and vein are catheterized and circulating blood is diverted from the artery into the shunt tubing and back into the femoral vein. Blood is shunted through the tubing for two hours at unrestricted flow rates and normal blood pressures.

The tubes 12 of polyester elastomer not containing cells were introduced into the above system under the specified conditions. When polyester elastomer tubing is run in the shunt without cells, the tubing surfaces  
5 12 pick up both red clot and white blood cells. In Figure 3C (cross section of tube viewed under low magnification (X 30.4)), large clots are easily observed. In Figure 3D (cross section of the tube  
10 entire surface has picked up elements from the blood and clot has begun to be deposited.

#### EXAMPLE 2

Tubes 12 of polyester elastomer including endothelial cells were used in the ex vivo shunt system  
15 described in the preceding Comparative Example. Autologous or allogeneic endothelial cells were seeded and grown on the luminal surface of the tubes 12 as described previously. The cells were grown on the  
20 polymer tubing surface for 48 hours and then exposed to blood flow in the ex vivo shunt. In Figure 3A (cross section of the tube viewed under low magnification (X 30.0)), it is seen that a smooth carpet of endothelial cells has remained attached to the polyester elastomer surface after two hours of flow. In Figure 3B (cross  
25 section of the tube viewed under high magnification (X 1000)), it is seen that the cells form a continuous monolayer with little or no obvious blood clot components visible on the surface.

Thus the polymeric substrate of this Example and  
30 including endothelial cells is superior to the substrate without cells of Comparative Example 3, in terms of the undesirable presence of blood clots and the cells remain attached under normal blood flow conditions.



EXAMPLE 4

A solution of segmented polyurethane in N,N-dimethylacetamide was prepared in accordance with the general procedure described in U.S. Patent 3,428,711 (e.g., first sentence of Example II and the description of Example I). An intimate mixture was prepared of p,p'-methylenediphenyl diisocyanate and polytetramethylene ether glycol (of about 1800 molecular weight) in a molar ratio of 1.70 and was held at 80° to 90°C for 90 to 100 minutes to yield an isocyanate-terminated polyether (i.e., a capped glycol), which was then cooled to 60°C and mixed with N,N-dimethylacetamide to provide a mixture containing about 45% solids. Then, while maintaining vigorous mixing, the capped glycol was reacted for 2 to 3 minutes at a temperature of about 75°C with diethylamine (a chain terminator) and an 80/20 molar ratio of ethylenediamine and 1,3-cyclohexylenediamine chain extenders. The molar ratio of diamine chain extender to diethylamine was 6.31 and the molar ratio of diamine chain extenders to unreacted isocyanate in the capped glycol was 0.948. The resultant solution of segmented polyurethane contained approximately 36% solids and had a viscosity of about 2100 poises at 40°C. This polymer had an intrinsic viscosity of 0.95, measured at 25°C in N,N-dimethylacetamide at a concentration of 0.5 gram per 100 ml of solution.

It is to be understood that a wide variety of modifications can be made to the present invention without departing from the spirit and the scope thereof.

30

35

CLAIMS

1. A polymeric substrate having cells attached thereto, said substrate comprising a copolymer of  
5 repeating units of a soft segment having carbon and oxygen in a ratio of from 2.6 to 4.5 and of repeating units of a crystallizable hard segment.
2. The substrate of Claim 1 wherein the soft  
10 segment is poly(tetramethylene ether glycol).
3. The substrate of Claim 2 wherein the crystallizable hard segment is poly(butylene terephthalate).  
15
4. The substrate of Claim 2 wherein the crystallizable hard segment is the reaction product of ethylene diamine with methylene bis(4,4'-diphenyl-isocyanate).  
20
5. The substrate of Claim 3 wherein the copolymer contains from about 18 to about 77 weight percent of repeating units of said soft segment and from about 23 to about 82 weight percent of repeating units of said  
25 crystallizable hard segment.
6. The substrate of Claim 3 wherein the copolymer contains from about 65 to about 77 weight percent of repeating units of said soft segment and from about 23  
30 to about 35 weight percent of repeating units of said crystallizable hard segment.
7. The substrate of Claim 4 wherein the copolymer contains from about 85 to about 95 weight percent of  
35 repeating units of said soft segment and from about 5 to

about 15 weight percent of repeating units of said crystallizable hard segment.

8. The substrate of Claim 4 wherein the copolymer  
5 contains from about 85 to about 90 weight percent of repeating units of said soft segment and from about 10 to about 15 weight percent of repeating units of said crystallizable hard segment.

10 9. The substrate of Claim 1 wherein the crystallizable hard segment is an aliphatic diacid.

10. The substrate of Claim 1 wherein the soft  
15 segment has a carbon to oxygen ratio of from 4.0 to 4.3.

11. The substrate of Claim 1 wherein the surface  
of said substrate adjacent to said cells is smooth.

12. The substrate of Claim 1 wherein the surface  
20 of said substrate adjacent to said cells is porous.

13. The substrate of Claim 1 wherein the cells are  
selected from the group consisting of fibroblasts,  
adipose cells, endothelial cells, epithelial cells,  
25 organ parenchymal cells, muscle cells, nerve cells,  
cartilage cells, bone cells and mixtures thereof.

14. The substrate of Claim 1 wherein the cells are  
endothelial cells.  
30

15. The substrate of Claim 1 further comprising an  
adsorption promoting layer of chemical compound  
interposed between said substrate and said cells.

16. A shaped article comprising a polymeric substrate having cells attached thereto, said substrate comprising a copolymer of repeating units of a soft segment having carbon and oxygen in a ratio of from 2.6  
5 to 4.5 and of repeating units of a crystallizable hard segment.

17. The shaped article of Claim 16 wherein the soft segment is poly(tetramethylene ether glycol).  
10

18. The shaped article of Claim 17 wherein the crystallizable hard segment is poly(butylene terephthalate).

19. The shaped article of Claim 17 wherein the crystallizable hard segment is the reaction product of ethylene diamine with methylene bis(4,4'-diphenyl-isocyanate).  
15

20. The substrate of Claim 18 wherein the copolymer contains from about 18 to about 77 weight percent of repeating units of said soft segment and from about 23 to about 82 weight percent of repeating units of said crystallizable hard segment.  
20

21. The substrate of Claim 18 wherein the copolymer contains from about 65 to about 77 weight percent of repeating units of said soft segment and from about 23 to about 35 weight percent of repeating units  
25 of said crystallizable hard segment.  
30

22. The substrate of Claim 19 wherein the copolymer contains from about 85 to about 95 weight percent of repeating units of said soft segment and from  
3

about 5 to about 15 weight percent of repeating units of said crystallizable hard segment.

23. The substrate of Claim 19 wherein the  
5 copolymer contains from about 85 to about 90 weight percent of repeating units of said soft segment and from about 10 to about 15 weight percent of repeating units of said crystallizable hard segment.

10 24. The shaped article of Claim 16 wherein the crystallizable hard segment is an aliphatic diacid.

25. The shaped article of Claim 16 which is planar, cylindrical, or spherical.

15

26. An article shaped as a vascular graft and connecting a vessel to another portion thereof or to another vessel, said article comprising a polymeric substrate having an interior surface and an exterior  
20 surface, the interior surface defining an aperture therethrough and having cells attached thereto, said substrate comprising a copolymer of repeating units of a soft segment having carbon and oxygen in a ratio of from .2.6 to 4.5 and of repeating units of a crystallizable  
25 hard segment.

27. The vascular graft of Claim 26 wherein the soft segment is poly(tetramethylene ether glycol) and the crystallizable hard segment is poly(butylene  
30 terephthalate).

28. The vascular graft of Claim 26 wherein the soft segment is poly(tetramethylene ether glycol) and the crystallizable hard segment is the reaction product

of ethylene diamine with methylene bis(4,4'-diphenyl-isocyanate).

29. The substrate of Claim 27 wherein the  
5 copolymer contains from about 18 to about 77 weight percent of repeating units of said soft segment and from about 23 to about 82 weight percent of repeating units of said crystallizable hard segment.

10 30. The substrate of Claim 27 wherein the copolymer contains from about 65 to about 77 weight percent of repeating units of said soft segment and from about 23 to about 35 weight percent of repeating units of said crystallizable hard segment.

15 31. The substrate of Claim 28 wherein the copolymer contains from about 85 to about 95 weight percent of repeating units of said soft segment and from about 5 to about 15 weight percent of repeating units of  
20 said crystallizable hard segment.

32. The substrate of Claim 28 wherein the copolymer contains from about 85 to about 90 weight percent of repeating units of said soft segment and from  
25 about 10 to about 15 weight percent of repeating units of said crystallizable hard segment.

33. The vascular graft of Claim 26 useful in blood vessel bypass procedures wherein said graft connects an  
30 artery to another portion thereof or to another artery.

34. The vascular graft of Claim 26 useful to enhance peripheral circulation and wherein said graft connects a blood vessel to another portion thereof or to  
35 another blood vessel.

35. The vascular graft of Claim 26 wherein the cells attached to the inner surface thereof are endothelial cells.

5

36. The vascular graft of Claim 26 wherein said endothelial cells remain secured thereto as fluid passes through said graft at flow rates of up to 200 ml/min. and pulsatile pressures of up to 150 over 80 mm Hg.

10

37. A method for the preparation of shaped articles comprising a polymeric substrate having cells attached thereto, said substrate comprising a copolymer of repeating units of a soft segment having carbon and oxygen in a ratio of from 2.6 to 4.5 and of repeating units of a crystallizable hard segment, said method comprising:

shaping said polymeric substrate into the desired shaped article; and  
attaching said cells to said polymeric substrate.

20

38. The method of Claim 37 wherein said cells are attached to said substrate by seeding the cells thereto.

25

39. The method of Claim 38 wherein said cells are grown in a culture medium prior to seeding to said substrate.

30

40. The method of Claim 38 wherein said cells are obtained from a tissue source prior to seeding to said substrate.

35

41. A method for the preparation of an article shaped as a vascular graft and connecting a vessel to

another portion thereof or to another vessel, said article comprising a polymeric substrate having an interior surface and an exterior surface, the interior surface defining an aperture therethrough and having  
5 cells attached to the inner surface thereof, said substrate comprising a copolymer of repeating units of a soft segment consisting of poly(tetramethylene ether glycol) and repeating units of a hard segment selected from the group consisting of poly(butylene  
10 terephthalate) and ethylene diamine with methylene bis(4,4'-diphenylisocyanate), said method comprising:

shaping said polymeric substrate into a shaped article having an interior surface and an exterior surface, said interior surface defining an aperture  
15 therethrough;

introducing cells into the interior surface of said fiber; and

subjecting the shaped article to conditions sufficient to allow the cells to grow to a desired  
20 density along the interior surface thereof.

42. The method of Claim 41 wherein the shaped article is a fiber.

25

30

35



1/4

FIG. 1

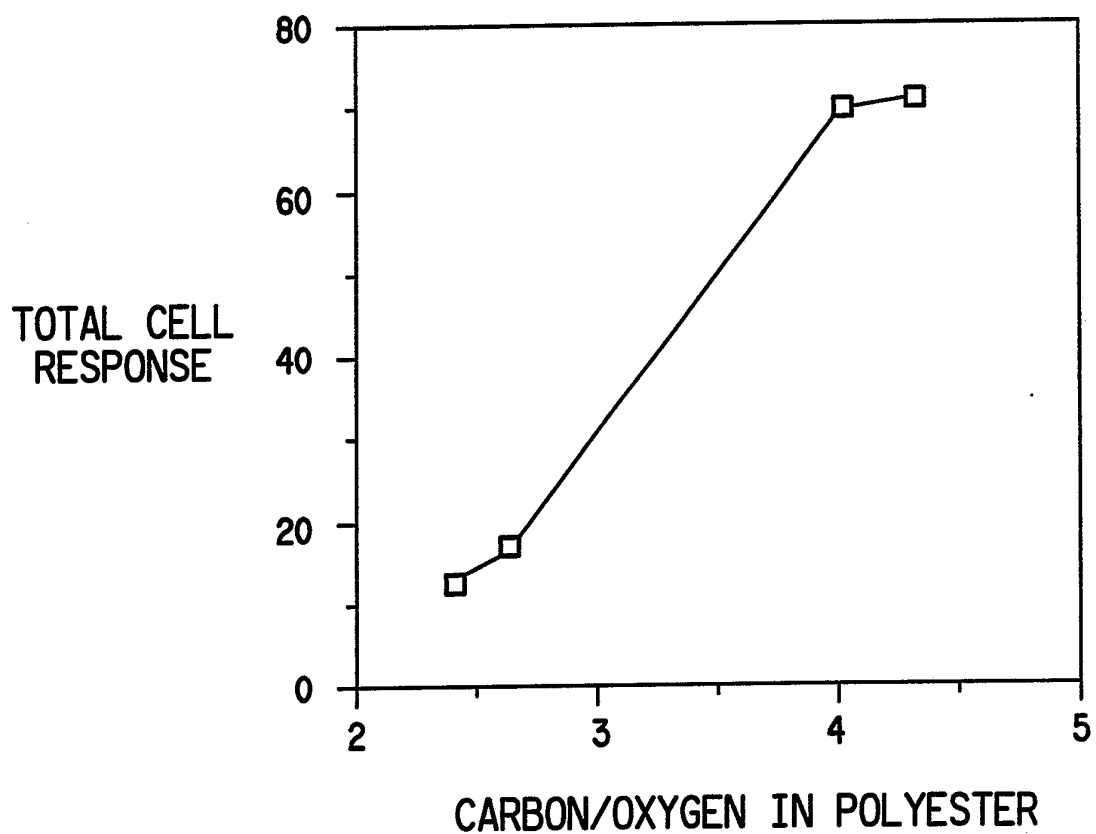
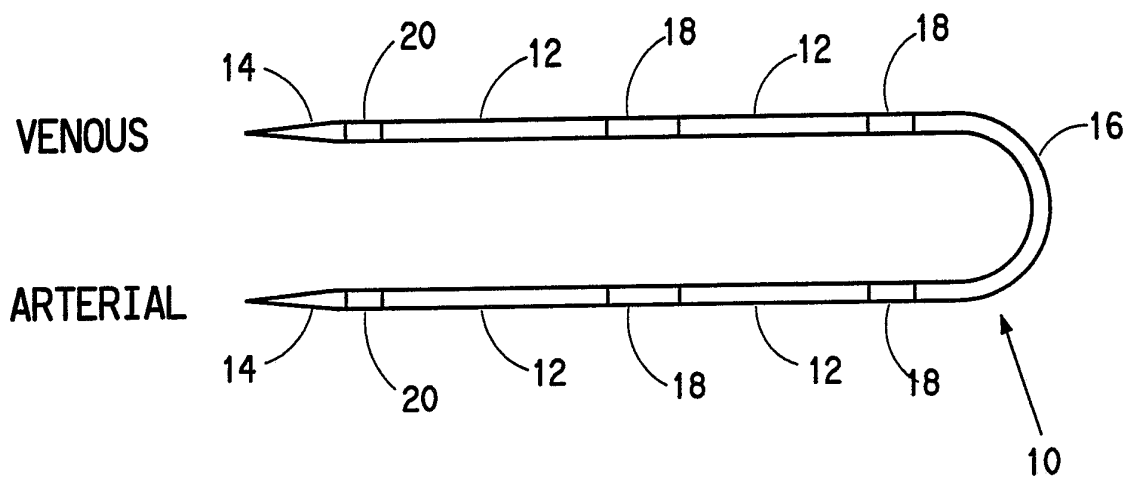

FIG. 2



3/4

FIG. 3A

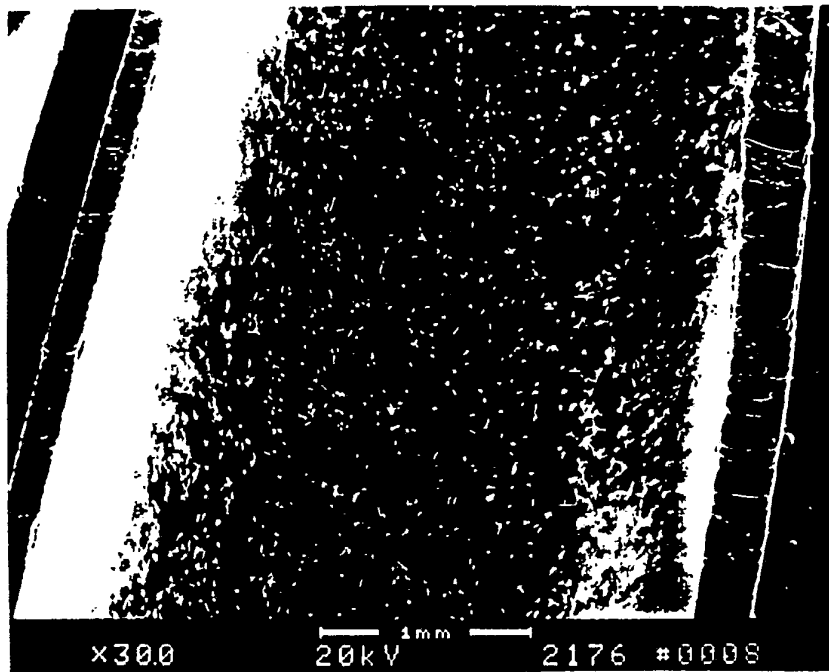

FIG. 3B



4/4

FIG. 3C

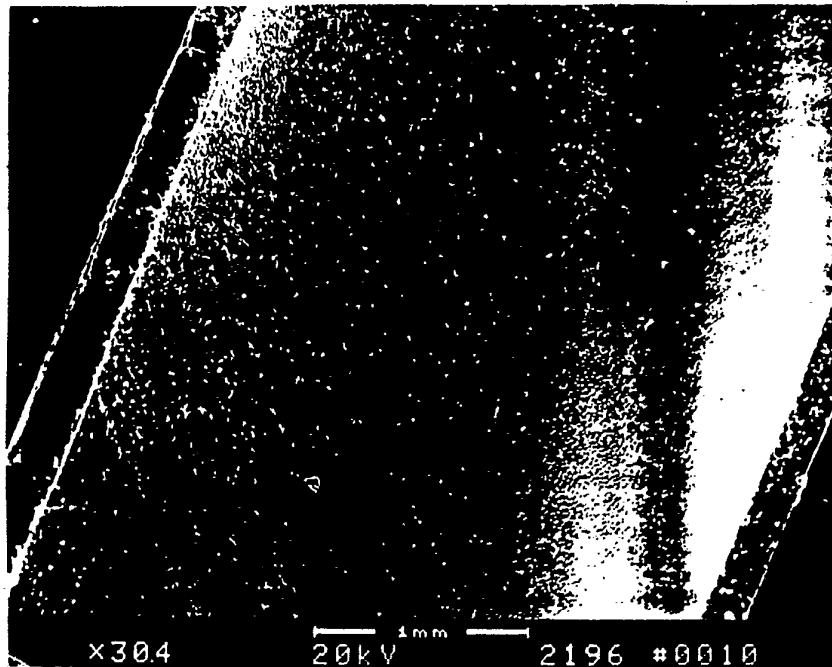
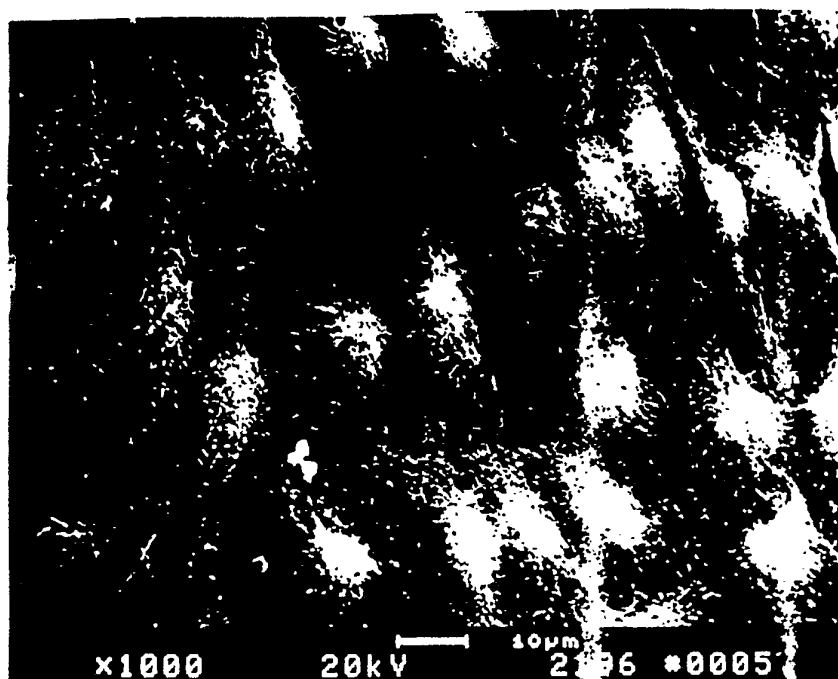

FIG. 3D



# INTERNATIONAL SEARCH REPORT

PCT/US 91/03905

International Application No

<b>I. CLASSIFICATION OF SUBJECT MATTER</b> (if several classification symbols apply, indicate all) <sup>6</sup>		
According to International Patent Classification (IPC) or to both National Classification and IPC Int.Cl. 5                    C12N5/00 ;    A61L27/00		
<b>II. FIELDS SEARCHED</b>		
Minimum Documentation Searched <sup>7</sup>		
Classification System	Classification Symbols	
Int.Cl. 5	C12N ;            A61L	
Documentation Searched other than Minimum Documentation to the Extent that such Documents are Included in the Fields Searched <sup>8</sup>		
<b>III. DOCUMENTS CONSIDERED TO BE RELEVANT<sup>9</sup></b>		
Category <sup>10</sup>	Citation of Document, <sup>11</sup> with indication, where appropriate, of the relevant passages <sup>12</sup>	Relevant to Claim No. <sup>13</sup>
X	M.D. LELAH ET AL. 'POLYURETHANES IN MEDICINE' 1986 , CRC PRESS, INC. , BOCA RATON, FLORIDA, US  see page 57 - page 59 see page 185 - page 199 see especially p.193, last line to p.194, l. 15 -----	1,2, 4-17, 19-26, 28-42
<p><sup>10</sup> Special categories of cited documents :</p> <p>"A" document defining the general state of the art which is not considered to be of particular relevance</p> <p>"E" earlier document but published on or after the international filing date</p> <p>"L" document which may throw doubts on priority claim(s) or which is cited to establish the publication date of another citation or other special reason (as specified)</p> <p>"O" document referring to an oral disclosure, use, exhibition or other means</p> <p>"P" document published prior to the international filing date but later than the priority date claimed</p> <p>"T" later document published after the international filing date or priority date and not in conflict with the application but cited to understand the principle or theory underlying the invention</p> <p>"X" document of particular relevance; the claimed invention cannot be considered novel or cannot be considered to involve an inventive step</p> <p>"Y" document of particular relevance; the claimed invention cannot be considered to involve an inventive step when the document is combined with one or more other such documents, such combination being obvious to a person skilled in the art.</p> <p>"&amp;" document member of the same patent family</p>		
<b>IV. CERTIFICATION</b>		
Date of the Actual Completion of the International Search	Date of Mailing of this International Search Report	
09 SEPTEMBER 1991	20. 09. 91	
International Searching Authority	Signature of Authorized Officer	
EUROPEAN PATENT OFFICE	RYCKEBOSCH A. <i>(Signature)</i>	