



US00D404210S

United States Patent [19]
Hutton

[11] **Patent Number: Des. 404,210**
[45] **Date of Patent: **Jan. 19, 1999**

- [54] **SEAT**
- [75] Inventor: **John Hutton**, New York, N.Y.
- [73] Assignee: **Donghia Furniture Co., Ltd.**, New York, N.Y.
- [**] Term: **14 Years**
- [21] Appl. No.: **81,772**
- [22] Filed: **Jan. 9, 1998**
- [51] **LOC (6) Cl.** **06-01**
- [52] **U.S. Cl.** **D6/361; D6/377**
- [58] **Field of Search** **D6/334, 335, 336, D6/360, 361, 377, 500, 501, 502; 5/12.1; 297/423.1**

- [56] **References Cited**
- U.S. PATENT DOCUMENTS**
- D. 366,571 1/1996 Hutton D6/361
- D. 376,921 12/1996 Chandler D6/334

OTHER PUBLICATIONS

Nic. Liesenbein's Sons, p. 93, Lounge #4025 at bottom right, ©1921.

St. James Club Chair 4001 and St. James Ottoman depicted in a Donghia Catalog page, 1989, Donghia Furniture Company, Ltd., New York, New.

St. James Sofa 4003 depicted in a Donghia Catalog page, 1990, Donghia Furniture Company, Ltd., New York, New York.

Madison Club Sofa depicted in a Donghia Catalog page, 1989, Donghia Furniture Company, Ltd., New York, New York.

Madison Club Chair 4101 and Madison Ottoman 4100 depicted in a Donghia Catalog page, 1980, Donghia Furniture Company, Ltd., New York, New York.

Primary Examiner—Gary D. Watson
Attorney, Agent, or Firm—Heslin & Rothenberg, P.C.

[57] **CLAIM**

The ornamental design for a seat, as shown and described.

DESCRIPTION

FIG. 1 is a top plan view of the seat comprising my new design;

FIG. 2 is a side elevational view thereof;

FIG. 3 is the opposite side elevational view thereof;

FIG. 4 is a front elevational view thereof; and,

FIG. 5 is a back elevational view thereof.

The broken line showing of leg members is for illustrative purposes only and forms no part of the claimed design.

1 Claim, 2 Drawing Sheets

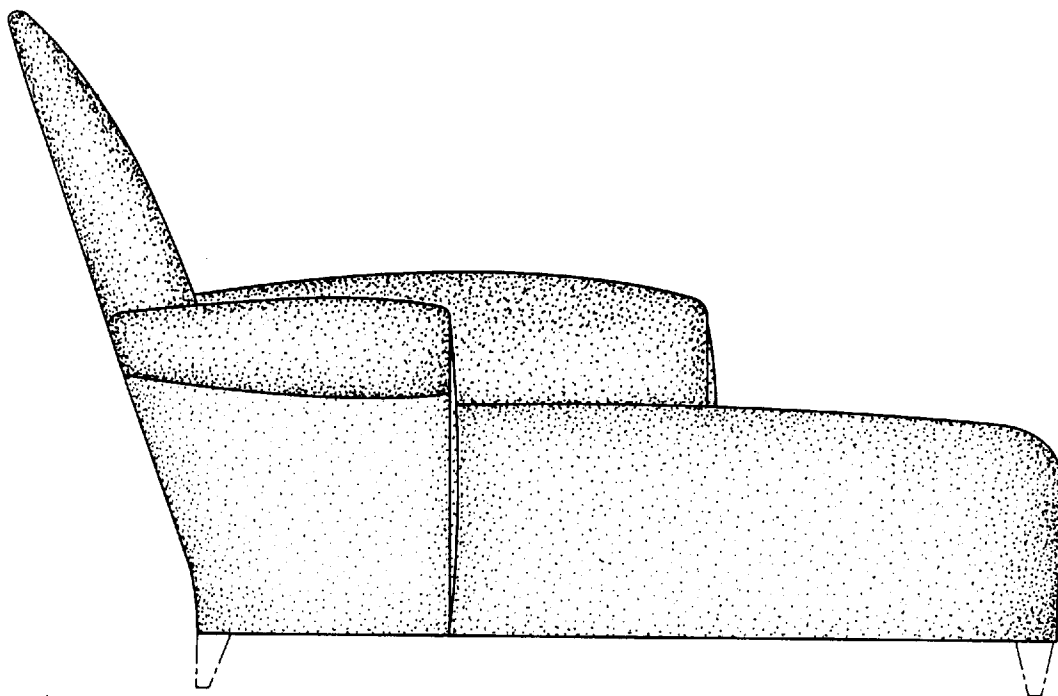

FIG. 1

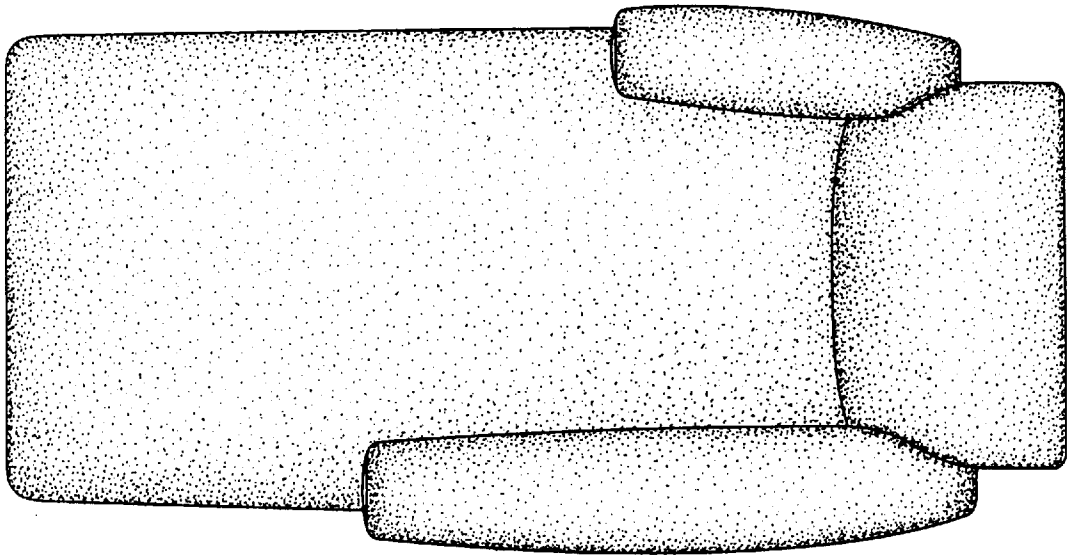

FIG. 2

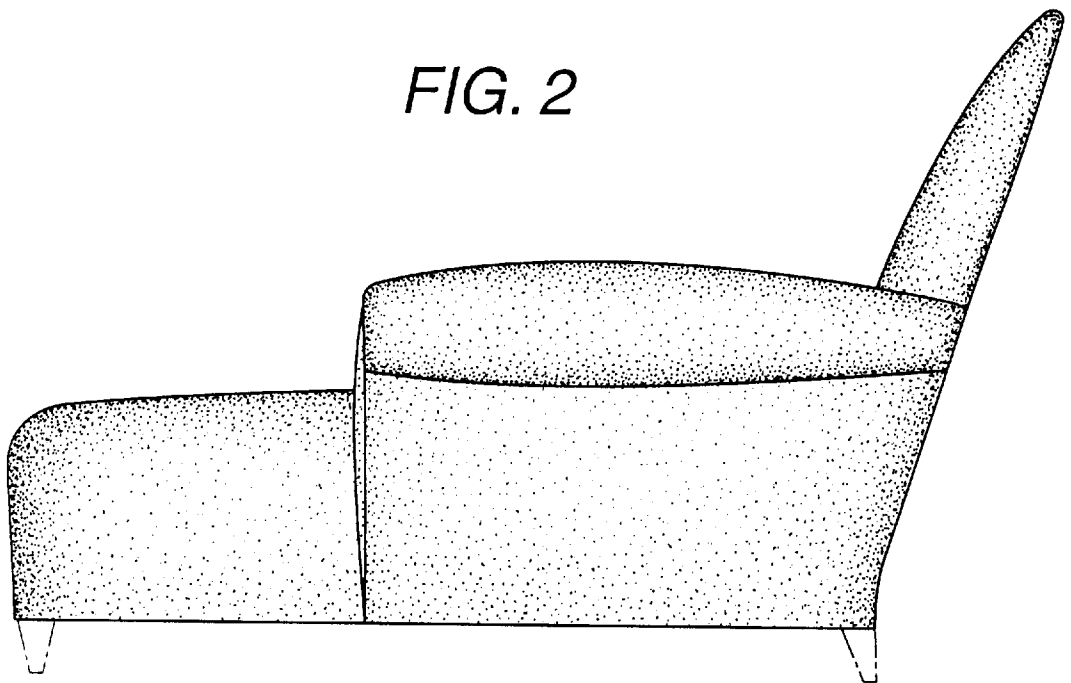

FIG. 3

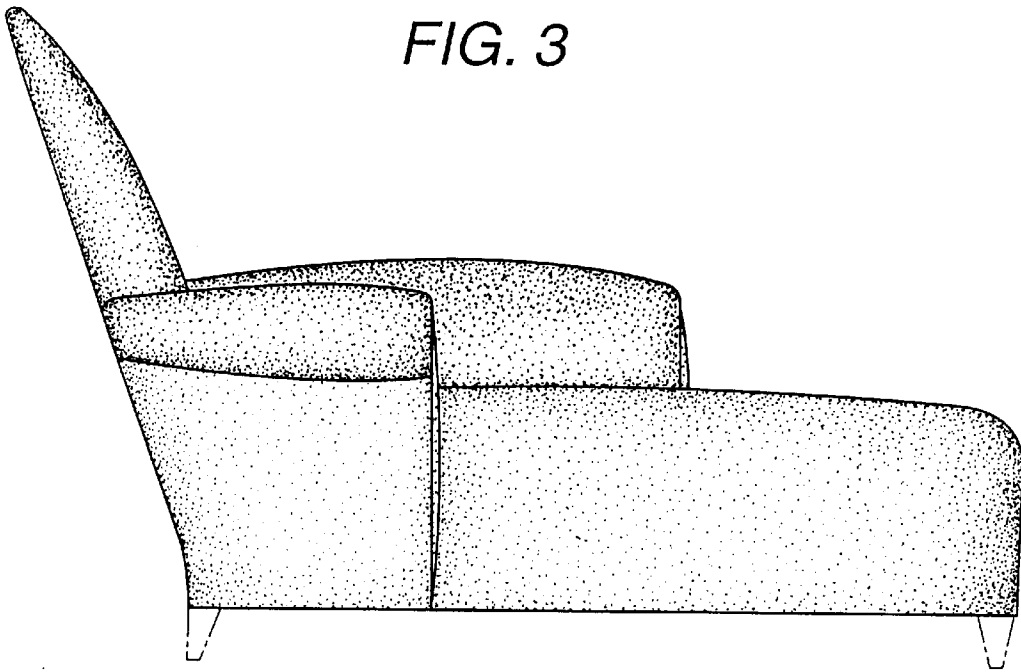

FIG. 4

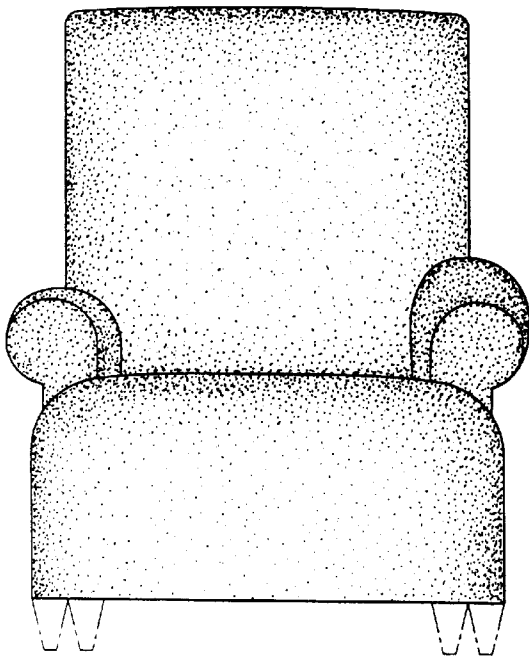

FIG. 5

