

(19)



(11)

EP 3 374 711 B1

(12)

EUROPEAN PATENT SPECIFICATION

(45) Date of publication and mention of the grant of the patent:
07.04.2021 Bulletin 2021/14

(51) Int Cl.:
F25D 29/00 (2006.01)

(21) Application number: **15793813.5**

(86) International application number:
PCT/EP2015/076313

(22) Date of filing: **11.11.2015**

(87) International publication number:
WO 2017/080595 (18.05.2017 Gazette 2017/20)

(54) **REFRIGERATED SALES FURNITURE**

GEKÜHLTES VERKAUFSMÖBELSTÜCK

MEUBLE POUR LA VENTE DE PRODUITS RÉFRIGÉRÉS

(84) Designated Contracting States:
AL AT BE BG CH CY CZ DE DK EE ES FI FR GB GR HR HU IE IS IT LI LT LU LV MC MK MT NL NO PL PT RO RS SE SI SK SM TR

(74) Representative: **Schmitt-Nilson Schraud Waibel Wohlfrom Patentanwälte Partnerschaft mbB Pelkovenstraße 143 80992 München (DE)**

(43) Date of publication of application:
19.09.2018 Bulletin 2018/38

(56) References cited:
**WO-A1-2014/168265 JP-A- H 109 753
JP-A- 2001 183 051 JP-A- 2012 112 646
JP-A- 2014 196 851 US-A1- 2014 165 614**

(73) Proprietor: **Carrier Corporation Farmington, CT 06034 (US)**

(72) Inventor: **COLDRE, Laurent 45504 Gien (FR)**

EP 3 374 711 B1

Note: Within nine months of the publication of the mention of the grant of the European patent in the European Patent Bulletin, any person may give notice to the European Patent Office of opposition to that patent, in accordance with the Implementing Regulations. Notice of opposition shall not be deemed to have been filed until the opposition fee has been paid. (Art. 99(1) European Patent Convention).

Description

[0001] The invention relates to a refrigerated sales furniture, in particular to a refrigerated sales furniture comprising at least one identification device, which is configured for identifying products while they are put into and/or taken out of the refrigerated sales furniture.

[0002] Refrigerated sales furnitures such as refrigerated sales cabinets and refrigerated sales islands provide the bridge between retailers and consumers.

[0003] It therefore is desirable to provide specific information about the products stored within those furnitures. Even scanning and registering the products, which are sold, at the cashier devices, cannot provide detailed and reliable information about the current stock, as scanning the products at the cashier devices does not provide specified real time information for each furniture.

[0004] It therefore would be beneficial to provide an improved refrigerated sales furniture, which allows to keep track of its contents, i.e. of products put into and taken out of the furniture, in real-time.

[0005] JP 2001 183 051 A discloses a store management system including a digital camera installed in the vicinity of a commodity-take-out opening of a showcase. A commodity to be placed in the showcase is marked with commodity tag in advance. When the commodity is taken out from the showcase, the tag is snapped by the camera, the commodity kind is identified by the taken digital picture, and information on the commodity taken out of the showcase is displayed on a home page.

[0006] According to an embodiment of the invention, a refrigerated sales furniture comprises the technical features as recited in claim 1.

[0007] According to an embodiment of the invention, a method of operating a refrigerated sales furniture is provided.

[0008] A refrigerated sales furniture and a method of operating a refrigerated sales furniture according to exemplary embodiments of the invention allow to reliably keep track of the contents of the refrigerated sales furniture by identifying all products, which are put into and taken out of the refrigerated sales furniture, in real-time.

[0009] As the products are identified based on respective optical properties of the products, in particular their size/volume, shape and/or color, there is no need to add additional markers such as barcodes, QR-codes etc. to the product. When using such optical properties for identifying the products passing through the at least one access area, appropriate image processing techniques and appropriate comparison techniques of such processed images with reference images stored for each product in one or more appropriate data bases may be used.

[0010] The information provided by a refrigerated sales furniture according to an exemplary embodiment of the invention may be used for generating statistics of movements and stocks of individual products for each furniture.

[0011] Exemplary embodiments will be described with

reference to the enclosed figures:

Figure 1 shows a schematic perspective view of a refrigerated sales furniture according to an exemplary embodiment of the invention.

Figure 2 shows a schematic perspective view of a compartment of a refrigerated sales furniture according to an exemplary embodiment of the invention.

Figure 3 shows an enlarged view of a product reader bar, as it is shown at the front edge of the upper shelf of Figure 2.

[0012] Figure 1 shows a schematic perspective view of a refrigerated sales furniture 2 according to an exemplary embodiment of the invention.

[0013] In Figures 1 to 3 a refrigerated sales cabinet is shown as an example of a refrigerated sales furniture 2. The refrigerated sales furniture 2 typically comprises a plurality of refrigerated sales spaces 5a-5e, which are configured for storing products 20 to be presented therein. An access area 3 providing access to the refrigerated sales spaces 5a-5e is formed by the upright front portion located in front of the refrigerated sales spaces 5a-5e of the refrigerated sales furniture 2. A plurality of shelves or racks, which are not shown in Figure 1, may be provided within the refrigerated sales spaces 5a-5e for accommodating and supporting the products 20 to be stored.

[0014] The skilled person, however, will easily understand that the invention may be applied to other types of refrigerated sales furnitures 2 as well, for example to refrigerated sales islands or refrigerated sales chests, in which the products 20 to be presented therein are stored on a bottom portion thereof and in which the access area providing access to the refrigerated sales space is formed by the upper horizontal portion of the refrigerated sales island or chest, which is located above the refrigerated sales space.

[0015] The refrigerated sales furniture 2 shown in Figure 1 has a furniture body and comprises a plurality of compartments 4a-4e positioned adjacent to each other. Each of the plurality of compartments 4a-4e defines at least one refrigerated sales space 5a-5e. The refrigerated sales spaces 5a-5e may be equipped with a plurality of shelves or racks 10a, 10b, which are not shown in Figure 1. The shelves 10a, 10b may be arranged on top of each other in the refrigerated sales space 5a-5e for receiving and supporting products 20, which are to be stored within the refrigerated sales furniture 2.

[0016] Each of the compartments 4a-4e may be provided with at least one door 15a-15e, 17a-17e at the access area 3. The at least one door 15a-15e, 17a-17e may be at least partially transparent. In an alternative embodiment, the open access area 3 may provide free access to the products 20 provided in the respective refrigerated sales space 5a-5e, without doors.

[0017] Figure 1 further depicts an embodiment of an identification device 13 which includes a plurality of cameras 6a, 6b, 6c directed onto the access areas 3 of the compartments 4a-4e for taking pictures of products 20 which are put into or taken out of the refrigerated sales spaces 5a-5e of the compartments 4a-4e. The cameras 6a, 6b, 6c of the identification device 13 may be mounted to the compartments 4a-4e, in particular to upper portions of the compartments 4a-4e. Alternatively, the cameras 6a, 6b, 6c may be mounted to the ceiling or to walls/pillars of a room housing the refrigerated sales furniture 2.

[0018] Each of the cameras 6a, 6b, 6c has a corresponding image capturing area 8a, 8b, 8c covering a part of the front portion of the refrigerated sales furniture 2. Each image capturing area 8a, 8b, 8c is associated with one of the compartments 4a-4e. An image capturing area 8a, 8b, 8c also may encompass a plurality of compartments 4a-4e. Adjacent image capturing areas 8a, 8b, 8c may overlap, as it is illustrated in Figure 1.

[0019] The identification device 13 further comprises an identification unit 9 connected with the cameras 6a, 6b, 6c. The identification unit 9 is configured for evaluating the pictures provided by the cameras 6a, 6b, 6c for identifying products 20 passing the access area 3 of the compartments 4a-4e and determining which products 20 are put into and/or taken out of the refrigerated sales furniture 2. The connection between the cameras 6a, 6b, 6c and the identification unit 9 may be provided by cables 25a, 25b, 25c or by wireless data connections.

[0020] The identification unit 9 is coupled with a tracking unit 21, which is configured for keeping track of the products 20 put into and/or taken out of the refrigerated sales furniture 2. This allows the tracking unit 21 to always provide up-to-date information about the products 20 being present within the the refrigerated sales spaces 5a-5e of the refrigerated sales furniture 2. The tracking unit 21 may be provided integrated with or separated from the identification unit 9.

[0021] The identification unit 9 and the tracking unit 21 may be located in at least one of the compartments 4a-4e. Alternatively, the identification unit 9 and the tracking unit 21 may be provided in some distance from the refrigerated sales furniture 2, e.g. in a separate room (not shown). In an embodiment, one central identification unit 9, which is connected to all cameras 6a, 6b, 6c within a store may be provided. Similarly, a central tracking unit 21, which is connected to a central identification unit 9 or to a plurality of distributed identification units 9, may be provided.

[0022] In a further embodiment, the cameras 6a, 6b, 6c may be connected to a remote identification unit 9, which is configured for evaluating the pictures provided from cameras 6a, 6b, 6c, which are located in a plurality of stores. The remote identification unit 9 may be integrated with or connected to a corresponding remote tracking unit 21. With such a configuration, the stock of a plurality of stores may be monitored employing only a single identification unit 9 and a single tracking unit 21.

[0023] The cameras 6a, 6b, 6c and the identification unit 9 further may be configured for detecting whether the doors 15a-15e, 17a-17e are completely closed. This allows the identification unit 9, the tracking unit 21 or an additional door monitoring unit 23, which is connected with the identification unit 9, to issue an alarm signal in case at least one of the doors 15a-15e, 17a-17e is not completely closed for more than a predetermined period of time.

[0024] The identification device 13 may further include at least one illumination device 7, which is configured for illuminating the access area 3 of the refrigerated sales furniture 2.

[0025] By illuminating the access area 3, the reliability of identifying products 20 passing through the access area 3 based on their optical properties may be improved. The at least one illumination device 7 in particular may provide white light comprising all colors of the spectrum in order to facilitate the identification of the products 20 based on their respective color(s). Optionally, the at least one illumination device 7 may provide IR-light or UV-light, which may be reflected by corresponding labels 24 attached to at least some of the products 20. The illumination device 7 also may comprise a laser light source, which might be beneficial for detecting optical codes such as bar codes.

[0026] The at least one illumination device 7 may be mounted to the compartments 4a-4e, in particular to a top portion of each of the compartments 4a-4e, or to the ceiling and/or to walls/pillars of the room housing the refrigerated sales furniture 2.

[0027] Figure 2 depicts a schematic perspective view of a compartment 4a of a refrigerated sales furniture 2 according to an exemplary embodiment of the invention. The compartment 4a may be one of a plurality of adjacent compartments 4a-4e, as illustrated in Figure 1, or it may be a single compartment 4a constituting a complete refrigerated sales furniture 2 on its own.

[0028] The compartment 4a may comprise components of a refrigeration circuit, i.e. an evaporator, a compressor, a condenser and an expansion device, which are not shown in Figure 2. The compressor and the condenser may also be located outside the compartment 4a, e.g. in a machine room or on the outside/on the roof of the building housing the refrigerated sales furniture 2, respectively.

[0029] The compartment 4a is provided with a plurality of horizontally extending shelves 10a, 10b, which are arranged on top of each other. Depending on the kind of products 20 to be stored within the refrigerated sales furniture 2, other types of storage means, e.g. inclined shelves, chests, trays etc. may be provided as well.

[0030] In the embodiment shown in Figure 2, cameras 6a, 6b, 6c and/or RFID readers 6d, 6e, 6f, which are not visible in Figure 2, are provided inside a product reader bar 12, which is provided at the front edge of an upper shelf 10a. In such a configuration, cameras 6a, 6b, 6c, which are provided inside the product reader bar 12, are

configured for taking pictures of products 20 passing an upright middle portion 3b of the access area 3 when being placed onto or taken from a lower shelf 10b, which is provided below the upper shelf 10a.

[0031] Alternatively or additionally, RFID readers 6d, 6e, 6f are provided inside the product reader bar 12, and they are configured for receiving signals from RFID tags comprised in labels 24 which are attached to products 20 passing an upright middle portion 3b of the access area 3 when being placed onto or taken from a lower shelf 10b. The RFID readers 6d, 6e, 6f associated with the middle portion 3b of the access area 3 in particular are configured not to receive signals from RFID tags attached to products 20 passing the upper or lower portions 3a, 3c of the access area 3.

[0032] An additional product reader bar 12 (not shown) comprising additional cameras 6a, 6b, 6c and/or RFID readers 6d, 6e, 6f may be provided at an upper ceiling 11 of the compartment 4a for detecting products 20 passing an upright upper portion 3a of the access area when being placed onto or taken from the upper shelf 10a.

[0033] Similarly, an additional reader bar 12 (not shown) comprising cameras 6a, 6b, 6c and/or RFID readers 6d, 6e, 6f may be provided at the front edge of the lower shelf 10b for detecting products 20 passing an upright lower portion 3c of the access area 3 when being put into or taken from a bottom refrigerated sales space 19, which is provided below the lower shelf 10b at the bottom of the compartment 4a.

[0034] By providing the product reader bar 12 at the front edge of the shelves 10a, 10b or at the front edge of the ceiling 11, respectively, it is accomplished that all products 20 passing the access area 3 are reliably detected by at least one of the cameras 6a, 6b, 6c and/or RFID readers 6d, 6e, 6f when being placed onto or taken out of one of the shelves 10a, 10b or the lower refrigerated sales space 19, respectively. In consequence, no products 20 can be taken from or put into the refrigerated sales space 5a, 19 of the compartment 14a without being detected by the identification device 13.

[0035] At least one illumination device 7, which is not visible in Figure 2, may be additionally provided within or next to the product reader bar 12 for illuminating the products 20 when passing the access area 3. The at least one illumination device 7 may be activated based on the intensity of ambient light within the access area 3 and/or only when at least one product 20 is detected within the access area 3.

[0036] Figure 3 shows an enlarged view of a product reader bar 12, as it is provided at the front edge of the upper shelf 10a shown in Figure 2.

[0037] The product reader bar 12 comprises a cap 14 formed by half of a tube which has been cut along its longitudinal direction. The cap 14 is attached to the lower side of the shelf 10a by means of an appropriate adhesive 18 providing a cavity extending along the front edge of the shelf 10a and being defined by the cap 14 and the shelf 10a. The lateral end sides of the cavity are closed

by means of end plates 16 provided at each lateral end of the product reader bar 12.

[0038] Alternatively or additionally to fixing the cap 14 by means of an adhesive 18, the cap 14 may be fixed to the shelf 10a by means of one or more mechanical fixtures 22, which are configured for fixing the cap 14 removably or permanently to the shelf 10a. The fixtures 22 in particular may include bolts, screws and clips.

[0039] Cameras 6a, 6b, 6c and/or RFID readers 6d, 6e, 6f are provided inside the cavity formed by the cap 14 and the shelf 10a. At least one illumination device 7 (not shown in Figure 3), may be provided within said cavity, as well.

[0040] At least in case cameras 6a, 6b, 6c are provided inside the cap 14, the cap 14 is at least partially formed from a transparent material, e.g. plexi-glass. The cap 14 protects the at least one camera 6a, 6b, 6c, RFID readers 6d, 6e, 6f and/or the at least one illumination device 7 from adverse effects, in particular from being hit and damaged by products 20 placed into or taken out of the refrigerated sales furniture 2.

[0041] A number of optional features are set out in the following. These features may be realized in particular embodiments, alone or in combination with any of the other features.

[0042] In an embodiment, the at least one identification device comprises at least one camera, which is configured for capturing pictures of products passing the at least one access area, and at least one identification unit, which is configured for identifying the products passing through the at least one access area from the pictures captured by the at least one camera, based on the optical properties of said products.

[0043] In an embodiment, the identification device is configured for identifying the products based on an optical code provided on the respective product. The code may be a usual barcode (e.g. one of the EAN, UPC, IAN and JAN codes), which already is provided on almost every product intended for sale. The code also may be an additional/new code, in particular a two-dimensional code, e.g. a QR-code, which is configured to be identified faster, more easily and/or more reliably than a barcode. An optical code allows a very reliable and unique identification of the products.

[0044] When using such optical code provided on the respective product for identifying the products passing through the at least one access area, the captured codes may be associated to reference codes stored for each product in one or more appropriate data bases.

[0045] The identification of an optical code attached to the product also may be used for confirming a previous identification, which has been made based on the size/volume, the shape and/or the color of the product or its packing. The optical code may be printed directly onto the product or its packing. Alternatively, the optical code may be printed on a label, which is attached to the product or its packing.

[0046] In an embodiment, the identification device is

configured as a barcode reader which is configured for identifying the products based on a barcode, which is attached to each of the products.

[0047] In an embodiment, the identification device is further configured for identifying additional information provided by the identified product or its packing. Said additional information in particular may include the production date and/or the best before date of the respective product. Identifying and keeping track of such information allows to optimize the stock-keeping even further. In particular, products may be taken out of the refrigerated sales furniture just before or at the best before date or after the best before date has passed and new products replacing said products may be ordered automatically or manually in due time.

[0048] In an embodiment, the cameras and the identification unit are configured for detecting whether the doors are completely closed. This allows the identification unit, the tracking unit or a special door monitoring unit to issue an alarm signal in case at least one of the doors is not completely closed for more than a predetermined period of time and helps to avoid that energy is wasted by operating the refrigerated sales furniture with the doors not being completely closed for a substantial period of time.

[0049] In an embodiment, the refrigerated sales furniture comprises at least one illumination device, which is configured for illuminating the products passing through the at least one access area. By illuminating the products passing through the at least one access area the reliability of identifying products passing through the at least one access area based on their optical properties may be considerably enhanced. The illumination device in particular may provide white light comprising all colors of the spectrum in order to facilitate the identification of the products based on their respective color(s). Optionally, the illumination device may provide IR-light and/or UV-light, which may be reflected by corresponding reflectors attached to at least some of the products.

[0050] In an embodiment, the at least one identification device comprises at least one RFID reader and at least one identification unit, which is connected with the at least one RFID reader. In such an embodiment the products may be uniquely identified by means of RFID tags which are attached to the respective product. RFID tags allow a reliable and unique identification of the products.

[0051] In an embodiment, the at least one access area is an open access area providing free access to the refrigerated sales space. An open access area is very convenient for the costumers, as it does not require the costumers to open doors or flaps for accessing the products stored within the refrigerated sales space of the furniture.

[0052] In an embodiment, the refrigerated sales furniture comprises at least one door or flap, which allows for closing the access area. Providing a door or flap closing the access area reduces the energy needed for operating the refrigerated sales furniture, i.e. for cooling the refrigerated sales space, as warm air is prevented from enter-

ing into the refrigerated sales space and refrigerated air is prevented from flowing out of the refrigerated sales space when the at least one door or flap is closed. The at least one door or flap may be at least partially transparent for allowing customers to look into the refrigerated sales space without opening the at least one door or flap.

[0053] In an embodiment, the at least one identification device is configured to be activated when the at least one flap or door is opened, and to be deactivated when the at least one flap or door is closed. In such an embodiment, the at least one identification device is active only when the at least one door or flap has been opened for allowing products to be put into or taken out of the refrigerated sales space. As the at least one identification device is deactivated, when the at least one door or flap is closed, the amount of energy consumed by the at least one identification device is reduced. Additionally, the risk of a false identification of products is minimized as well.

[0054] In an embodiment, the refrigerated sales space comprises at least one shelf or rack which is configured for receiving and supporting products to be stored. At least one camera and/or at least one RFID reader may be mounted to said at least one shelf. Installing at least one camera and/or at least one RFID reader at a shelf provided within the refrigerated sales space allows to identify the products put onto and taken from said shelf or an adjacent shelf, which is arranged above or below the shelf the camera and/or the RFID reader is attached to. Such a configuration in particular allows to identify products based on the shelf they are taken from. It further allows to provide more detailed product movement and product stock statistics, which in particular may include information related to the location of the products within the furniture.

[0055] In an embodiment, the refrigerated sales space is provided with a plurality of regions which are cooled to different temperatures, e.g. cooling temperatures above 0 °C and freezing temperatures below 0 °C, in particular below -10 °C. In this configuration, providing an identification device at every shelf allows to verify whether each product is placed on a shelf in the correct temperature region.

[0056] According to the present invention, the refrigerated sales furniture is configured for determining the region or the shelf in/on which the product is placed, e.g. by determining the portion of the access area through which the product is passed.

[0057] In an embodiment, the refrigerated sales furniture is configured for triggering an alarm when a product is placed into a wrong temperature region or onto a wrong shelf within the refrigerated sales space. This helps to avoid products from being spoiled or damaged by being placed into a wrong area of the refrigerated sales space, in particular into an area, in which the temperatures are too high or too low for the respective product.

[0058] In an embodiment, at least one camera and/or at least one RFID reader is installed above at least one shelf and/or at least one camera and/or at least one RFID

reader is installed at an edge of said shelf. Installing at least one camera and/or at least one RFID reader above and/or at the edge of the shelf allows the at least one identification device to reliably identify a product, which is put into and/or taken out of the refrigerated sales space.

[0059] In an embodiment, the at least one camera and/or at least one RFID reader is installed at a front portion of a shelf and being configured to identify products which are placed onto and/or are taken from said self. In such an embodiment the detection area of the at least one camera and/or at least one RFID reader is facing basically upwards. This provides a very compact configuration, which allows to reliably identify a product, which is put onto and/or taken from such a shelf.

[0060] In order to allow the identification device to identify each product based on its inherent properties, pictures of all products, which are intended to be placed into the refrigerated sales furniture, may be stored in a storage device of the identification device. The identification device then may be configured for comparing current pictures of a product, which are provided by at least one of the cameras, with the previously stored pictures. The identification device in particular may be provided with a self-learning functionality, which allows adding additional pictures of new and/or previously known products to the previously stored pictures.

[0061] In an embodiment, the refrigerated sales furniture is configured for controlling the refrigeration based on the identified products, which have been put into the refrigerated sales space. This allows to operate the refrigerated sales furniture with high efficiency, as the actual (refrigerated) temperature is adjusted to the actual needs of the products stored within the refrigerated sales space. This securely avoids the products from being spoiled as a result from being stored at wrong, in particular too high, temperatures. It further avoids the refrigerated sales furniture from consuming too much energy by providing lower temperatures than needed for storing the respective products.

[0062] In an embodiment, the refrigerated sales furniture is configured for generating an order for new products based on the products which have been identified as having been taken out of the refrigerated sales space. Thus, new products for refilling the refrigerated sales furniture may be ordered automatically before the refrigerated sales furniture is completely empty. As a result, stock-keeping is facilitated, as it is not necessary to manually check the amount or number of products, which are still present within the refrigerated sales furniture, and to order new products as soon as the number or amount of products, which are still present within the refrigerated sales furniture, has reached a certain lower limit.

[0063] In summary, the stock-keeping of refrigerated products may be considerably facilitated by employing a refrigerated sales furniture and/or a method of operating such a refrigerated sales furniture according to exemplary embodiments of the invention.

[0064] While the invention has been described with ref-

erence to exemplary embodiments, it will be understood by those skilled in the art that various changes may be made and equivalents may be substituted for elements thereof without departing from the scope of the invention.

In addition many modifications may be made to adopt a particular situation or material to the teachings of the invention without departing from the essential scope thereof. Therefore, it is intended that the invention not be limited to the particular embodiment disclosed, but that the invention include all embodiments falling within the scope of the claims.

Reference Numerals

[0065]

2	refrigerated sales furniture
3	access area
3a	upper portion of the access area
3b	middle portion of the access area
3c	lower portion of the access area
4a-4e	compartments
5a-5e	refrigerated sales spaces
6a, 6b, 6c	cameras
6d, 6e, 6f	RFID readers
7	illumination device
8a, 8b, 8c	capturing areas
9	identification unit
10a, 10b	shelves
11	ceiling of the refrigerated sales furniture
12	product reader bar
13	identification device
14	cap
15a-15e	doors
16	end plate
17a-17e	doors
18	adhesive
19	bottom refrigerated sales space
20	product
21	tracking unit
22	fixture
23	door monitoring unit
24	label
25a, 25b, 25c	cables

Claims

1. Refrigerated sales furniture (2) comprising:

a furniture body including a plurality of compartments (4a-4e), each of the compartments (4a-4e) providing at least one refrigerated sales space (5a-5e) for storing products to be presented therein;

at least one access area (3) providing access to the refrigerated sales space (5a-5e); and

at least one identification device (13), which is arranged and configured for identifying products (20) passing through said at least one access area (3);

characterized in that the identification device (13) is configured for identifying the products (20) based on their size/volume and/or shape and/or color, the identification device (13) comprises a plurality of cameras (6a, 6b, 6c), wherein each of the cameras (6a, 6b, 6c) has a corresponding image capturing area (8a, 8b, 8c) covering a part of the front portion of the refrigerated sale furniture (2) and each image capturing area (8a, 8b, 8c) is associated with at least one of the compartments (4a-4e), respectively, and the refrigerated sales furniture (2) is configured for determining the regions of the refrigerated sales space (5a-5e) in which the products (20) are placed by determining the portion of the access area (3) through which the respective product (20) is passed.

2. Refrigerated sales furniture (2) of claim 1 further comprising at least one illumination device (7), in particular an IR-illumination device (7), which is configured for illuminating the products (20) passing through the at least one access area (3).
3. Refrigerated sales furniture (2) of one of the preceding claims, wherein the at least one identification device (13) comprises at least one RFID reader (6d, 6e, 6f).
4. Refrigerated sales furniture (2) of one of the preceding claims, comprising at least one flap or door (15a-15e, 17a-17e), which allows to shut the access area (3), wherein the at least one identification device (13) in particular is configured to be activated only when the at least one flap or door (15a-15e, 17a-17e) is open.
5. Refrigerated sales furniture (2) of any of the preceding claims, wherein the at least one identification device (13) is further configured for identifying additional information about the products (20), in particular including the production date and/ or the best before date of the identified product (20).
6. Refrigerated sales furniture (2) of one of the preceding claims, wherein the refrigerated sales space (5a-5e) comprises at least one shelf (10a, 10b) for receiving and supporting the products (20) to be stored, and wherein at least one camera (6a, 6b, 6c) and or at least one RFID reader (6d, 6e, 6f) is installed at said at least one shelf (10a, 10b).
7. Refrigerated sales furniture (2) of claim 6, wherein at least one camera (6a, 6b, 6c) or at least one RFID

reader (6d, 6e, 6f) is installed above said at least one shelf (10a, 10b), or wherein the at least one camera (6a, 6b, 6c) or at least one RFID reader (6d, 6e, 6f) is installed at a front edge of said at least one shelf (10a, 10b).

8. Refrigerated sales furniture (2) of one of the preceding claims which is configured for controlling the refrigeration based on the identified products (20).
9. Refrigerated sales furniture (2) of one of the preceding claims which is configured for triggering an alarm when a product (20) is placed into a wrong area of the refrigerated sales space (5a-5e).
10. Refrigerated sales furniture (2) of one of the preceding claims which is configured for generating an order for new products (20) based on the identified products (20).
11. Method of operating a refrigerated sales furniture (2), the refrigerated sales furniture (2) comprising:

a furniture body including a plurality of compartments (4a-4e), each of the compartments (4a-4e) providing at least one refrigerated sales space (5a-5e) for storing products to be presented therein;

at least one access area (3) providing access to the refrigerated sales space (5a-5e); and
at least one identification device (13), which is arranged and configured for identifying products (20) passing through said at least one access area (3);

wherein

the identification device (13) comprises a plurality of cameras (6a, 6b, 6c), each of the cameras (6a, 6b, 6c) having a corresponding image capturing area (8a, 8b, 8c) covering a part of the front portion of the refrigerated sale furniture (2) and each image capturing area (8a, 8b, 8c) being associated with at least one of the compartments (4a-4e), respectively, the identification device (13) is configured for identifying the products (20) based on their size/volume, shape and/or color; and

wherein the method comprises the step of identifying products (20) passing through the at least one access area (3) and determining the regions of the refrigerated sales space (5a-5e) in which the products (20) are placed by determining the portion of the access area (3) through which the respective product (20) is passed.

12. Method of claim 11, further comprising the step of controlling the refrigeration of the refrigerated sales furniture (2) based on the products (20) identified by the at least one identification device (13).

13. Method of claim 11 or 12, further comprising the step of ordering new products (20) based on the products (20) which have been identified as having been taken out of the refrigerated sales space (5a-5e).

wobei die mindestens eine Identifizierungsvorrichtung (13) insbesondere dazu konfiguriert ist, nur aktiviert zu werden, wenn die mindestens eine Klappe oder Tür (15a-15e, 17a-17e) geöffnet wird.

5

Patentansprüche

1. Gekühltes Verkaufsmöbel (2), umfassend:

einen Möbelkorpus, der eine Vielzahl von Fächern (4a-4e) aufweist, wobei jedes der Fächer (4a-4e) mindestens einen gekühlten Verkaufsraum (5a-5e) zum Aufbewahren von Produkten, die darin präsentiert werden sollen, bereitstellt; mindestens einen Zugangsbereich (3), der Zugang zu dem gekühlten Verkaufsraum (5a-5e) bereitstellt; und

mindestens eine Identifizierungsvorrichtung (13), die zum Identifizieren von Produkten (20), die den mindestens einen Zugangsbereich (3) passieren, angeordnet und konfiguriert ist;

dadurch gekennzeichnet, dass die Identifizierungsvorrichtung (13) zum Identifizieren der Produkte (20) auf Grundlage ihrer Größe / ihres Volumens und/oder ihrer Form und/oder Farbe konfiguriert ist, wobei die Identifizierungsvorrichtung (13) eine Vielzahl von Kameras (6a, 6b, 6c) umfasst, wobei jede der Kameras (6a, 6b, 6c) einen entsprechenden Bildaufnahmebereich (8a, 8b, 8c) aufweist, der einen Teil des vorderen Abschnitts des gekühlten Verkaufsmöbels (2) abdeckt, und jeder Bildaufnahmebereich (8a, 8b, 8c) mit je mindestens einem der Fächer (4a-4e) assoziiert ist und das gekühlte Verkaufsmöbel (2) konfiguriert ist, die Zonen des gekühlten Verkaufsraums (5a-5e), in denen die Produkte (20) platziert werden, durch Bestimmen des Abschnitts des Zugangsbereichs (3), den das jeweilige Produkt (20) passiert, zu bestimmen.

2. Gekühltes Verkaufsmöbel (2) nach Anspruch 1, ferner umfassend mindestens eine Beleuchtungsvorrichtung (7), insbesondere eine IR-Beleuchtungsvorrichtung (7), die zum Beleuchten der Produkte (20), die den mindestens einen Zugangsbereich (3) passieren, konfiguriert ist.
3. Gekühltes Verkaufsmöbel (2) nach einem der vorhergehenden Ansprüche, wobei die mindestens eine Identifizierungsvorrichtung (13) mindestens einen RFID-Leser (6d, 6e, 6f) umfasst.
4. Gekühltes Verkaufsmöbel (2) nach einem der vorhergehenden Ansprüche, umfassend mindestens eine Klappe oder Tür (15a-15e, 17a-17e), die es ermöglicht, den Zugangsbereich (3) zu verschließen,

10

5. Gekühltes Verkaufsmöbel (2) nach einem der vorhergehenden Ansprüche, wobei die mindestens eine Identifizierungsvorrichtung (13) ferner zum Identifizieren zusätzlicher Informationen über die Produkte (20) konfiguriert ist, zu denen insbesondere das Herstellungsdatum und/oder das Mindesthaltbarkeitsdatum des identifizierten Produkts (20) gehört/gehören.

15

6. Gekühltes Verkaufsmöbel (2) nach einem der vorhergehenden Ansprüche, wobei der gekühlte Verkaufsraum (5a-5e) einen Regalboden (10a, 10b) zum Aufnehmen und Halten der aufzubewahrenden Produkte (20) umfasst und wobei mindestens eine Kamera (6a, 6b, 6c) und/oder mindestens ein RFID-Leser (6d, 6e, 6f) an dem mindestens einen Regalboden (10a, 10b) installiert ist.

20

25

7. Gekühltes Verkaufsmöbel (2) nach Anspruch 6, wobei mindestens eine Kamera (6a, 6b, 6c) oder mindestens ein RFID-Leser (6d, 6e, 6f) über dem mindestens einen Regalboden (10a, 10b) installiert ist oder wobei die mindestens eine Kamera (6a, 6b, 6c) oder der mindestens eine RFID-Leser (6d, 6e, 6f) an einer Vorderkante des mindestens einen Regalbodens (10a, 10b) installiert ist.

30

35

8. Gekühltes Verkaufsmöbel (2) nach einem der vorhergehenden Ansprüche, das konfiguriert ist, die Kühlung auf Grundlage der identifizierten Produkte (20) zu steuern.

40

9. Gekühltes Verkaufsmöbel (2) nach einem der vorhergehenden Ansprüche, das konfiguriert ist, einen Alarm auszulösen, wenn ein Produkt (20) in einem falschen Bereich des gekühlten Verkaufsraums (5a-5e) platziert wird.

45

10. Gekühltes Verkaufsmöbel (2) nach einem der vorhergehenden Ansprüche, das konfiguriert ist, auf Grundlage der identifizierten Produkte (20) eine Bestellung neuer Produkte (20) zu erzeugen.

50

11. Verfahren zum Betreiben eines gekühlten Verkaufsmöbels (2), wobei das gekühlte Verkaufsmöbel (2) umfasst:

einen Möbelkorpus, der eine Vielzahl von Fächern (4a-4e) aufweist, wobei jedes der Fächer (4a-4e) mindestens einen gekühlten Verkaufsraum (5a-5e) zum Aufbewahren von Produkten, die darin präsentiert werden sollen, bereitstellt; mindestens einen Zugangsbereich (3), der Zu-

55

gang zu dem gekühlten Verkaufsraum (5a-5e) bereitstellt; und
 mindestens eine Identifizierungsvorrichtung (13), die zum Identifizieren von Produkten (20), die den mindestens einen Zugangsbereich (3) passieren, angeordnet und konfiguriert ist; wobei die Identifizierungsvorrichtung (13) eine Vielzahl von Kameras (6a, 6b, 6c) umfasst, wobei jede der Kameras (6a, 6b, 6c) einen entsprechenden Bildaufnahmebereich (8a, 8b, 8c) aufweist, der einen Teil des vorderen Abschnitts des gekühlten Möbels (2) abdeckt, und wobei jeder Bildaufnahmebereich (8a, 8b, 8c) mit je mindestens einem der Fächer (4a-4e) assoziiert ist, wobei die Identifizierungsvorrichtung (13) zum Identifizieren der Produkte (20) auf Grundlage ihrer Größe / ihres Volumens, ihrer Form und/oder Farbe konfiguriert ist; und wobei das Verfahren den Schritt umfasst, Produkte (20) zu identifizieren, die den mindestens einen Zugangsbereich (3) passieren, und durch Bestimmen des Abschnitts des Zugangsbereichs (3), den das jeweilige Produkt (20) passiert, die Zonen des gekühlten Verkaufsraums (5a-5e) zu bestimmen, in denen die Produkte (20) platziert werden.

12. Verfahren nach Anspruch 11, ferner umfassend den Schritt des Steuerns der Kühlung des gekühlten Verkaufsmöbels (2) auf Grundlage der Produkte (20), die durch die mindestens eine Identifizierungsvorrichtung (13) identifiziert wurden.
13. Verfahren nach Anspruch 11 oder 12, ferner umfassend den Schritt des Bestellens neuer Produkte (20) auf Grundlage der Produkte (20), die als aus dem gekühlten Verkaufsraum (5a-5e) entnommen identifiziert worden sind.

Revendications

1. Meuble pour la vente de produits réfrigérés (2) comprenant :

un corps de meuble comportant une pluralité de compartiments (4a-4e), chacun des compartiments (4a-4e) fournissant au moins un espace de vente de produits réfrigérés (5a-5e) pour stocker des produits devant y être présentés ; au moins une zone d'accès (3) fournissant un accès à l'espace de vente de produits réfrigérés (5a-5e) ; et au moins un dispositif d'identification (13), qui est agencé et conçu pour identifier des produits (20) traversant ladite au moins une zone d'accès (3) ;
caractérisé en ce que le dispositif d'identifica-

tion (13) est conçu pour identifier les produits (20) en fonction de leur taille/volume et/ou de leur forme et/ou de leur couleur, le dispositif d'identification (13) comprend une pluralité de caméras (6a, 6b, 6c), dans lequel chacune des caméras (6a, 6b, 6c) présente une zone de capture d'image (8a, 8b, 8c) correspondante couvrant une partie de la partie avant du meuble pour la vente de produits réfrigérés (2), et chaque zone de capture d'image (8a, 8b, 8c) est associée à au moins l'un des compartiments (4a-4e), respectivement, et le meuble pour la vente de produits réfrigérés (2) est conçu pour déterminer les régions de l'espace de vente de produits réfrigérés (5a-5e) dans lesquelles les produits (20) sont placés en déterminant la partie de la zone d'accès (3) traversée par le produit (20) respectif.

2. Meuble pour la vente de produits réfrigérés (2) selon la revendication 1, comprenant en outre au moins un dispositif d'éclairage (7), en particulier un dispositif d'éclairage IR (7), qui est conçu pour éclairer les produits (20) traversant l'au moins une zone d'accès (3).
3. Meuble pour la vente de produits réfrigérés (2) selon l'une des revendications précédentes, dans lequel l'au moins un dispositif d'identification (13) comprend au moins un lecteur RFID (6d, 6e, 6f).
4. Meuble pour la vente de produits réfrigérés (2) selon l'une des revendications précédentes, comprenant au moins un volet ou porte (15a-15e, 17a-17e), qui permet de fermer la zone d'accès (3), dans lequel l'au moins un dispositif d'identification (13) en particulier est conçu pour être activé uniquement lorsque l'au moins un volet ou porte (15a-15e, 17a-17e) est ouvert.
5. Meuble pour la vente de produits réfrigérés (2) selon l'une quelconque des revendications précédentes, dans lequel l'au moins un dispositif d'identification (13) est en outre conçu pour identifier des informations supplémentaires concernant les produits (20), en particulier comportant la date de fabrication et/ou la date de péremption du produit (20) identifié.
6. Meuble pour la vente de produits réfrigérés (2) selon l'une des revendications précédentes, dans lequel l'espace de vente de produits réfrigérés (5a-5e) comprend au moins une étagère (10a, 10b) destinée à recevoir et à soutenir les produits (20) à stocker, et dans lequel au moins une caméra (6a, 6b, 6c) et/ou au moins un lecteur RFID (6d, 6e, 6f) est/sont installé(s) au niveau de ladite au moins une étagère (10a, 10b).

7. Meuble pour la vente de produits réfrigérés (2) selon la revendication 6, dans lequel au moins une caméra (6a, 6b, 6c) ou au moins un lecteur RFID (6d, 6e, 6f) est installé au-dessus de ladite au moins une étagère (10a, 10b), ou dans lequel l'au moins une caméra (6a, 6b, 6c) ou au moins un lecteur RFID (6d, 6e, 6f) est installé au niveau d'un bord avant de ladite au moins une étagère (10a, 10b). 5
8. Meuble pour la vente de produits réfrigérés (2) selon l'une des revendications précédentes qui est conçu pour commander la réfrigération en fonction des produits (20) identifiés. 10
9. Meuble pour la vente de produits réfrigérés (2) selon l'une des revendications précédentes qui est conçu pour déclencher une alarme lorsqu'un produit (20) est placé dans une mauvaise zone de l'espace de vente de produits réfrigérés (5a-5e). 15
10. Meuble pour la vente de produits réfrigérés (2) selon l'une des revendications précédentes qui est conçu pour générer une commande de nouveaux produits (20) en fonction des produits (20) identifiés. 20
11. Procédé de fonctionnement d'un meuble pour la vente de produits réfrigérés (2), le meuble pour la vente de produits réfrigérés (2) comprenant : 25
- un corps de meuble comportant une pluralité de compartiments (4a-4e), chacun des compartiments (4a-4e) fournissant au moins un espace de vente de produits réfrigérés (5a-5e) pour stocker des produits devant y être présentés ; au moins une zone d'accès (3) fournissant un accès à l'espace de vente de produits réfrigérés (5a-5e) ; et 30
- au moins un dispositif d'identification (13), qui est agencé et conçu pour identifier des produits (20) traversant ladite au moins une zone d'accès (3) ; 35
- dans lequel 40
- le dispositif d'identification (13) comprend une pluralité de caméras (6a, 6b, 6c), chacune des caméras (6a, 6b, 6c) présentant une zone de capture d'image (8a, 8b, 8c) correspondante couvrant une partie de la partie avant du meuble pour la vente de produits réfrigérés (2), et chaque zone de capture d'image (8a, 8b, 8c) étant associée à au moins l'un des compartiments (4a-4e), respectivement, le dispositif d'identification (13) est conçu pour identifier les produits (20) en fonction de leur taille/volume, de leur forme et/ou de leur couleur ; et 45
- dans lequel le procédé comprend l'étape d'identification de produits (20) traversant l'au moins une zone d'accès (3) et de détermination des régions de l'espace de vente de produits réfri- 50
- gérés (5a-5e) dans lesquelles les produits (20) sont placés en déterminant la partie de la zone d'accès (3) traversée par le produit (20) respectif. 55
12. Procédé selon la revendication 11, comprenant en outre l'étape de commande de la réfrigération du meuble pour la vente de produits réfrigérés (2) en fonction des produits (20) identifiés par l'au moins un dispositif d'identification (13).
13. Procédé selon la revendication 11 ou 12, comprenant en outre l'étape de commande de nouveaux produits (20) en fonction des produits (20) qui ont été identifiés comme ayant été sortis de l'espace de vente de produits réfrigérés (5a-5e).

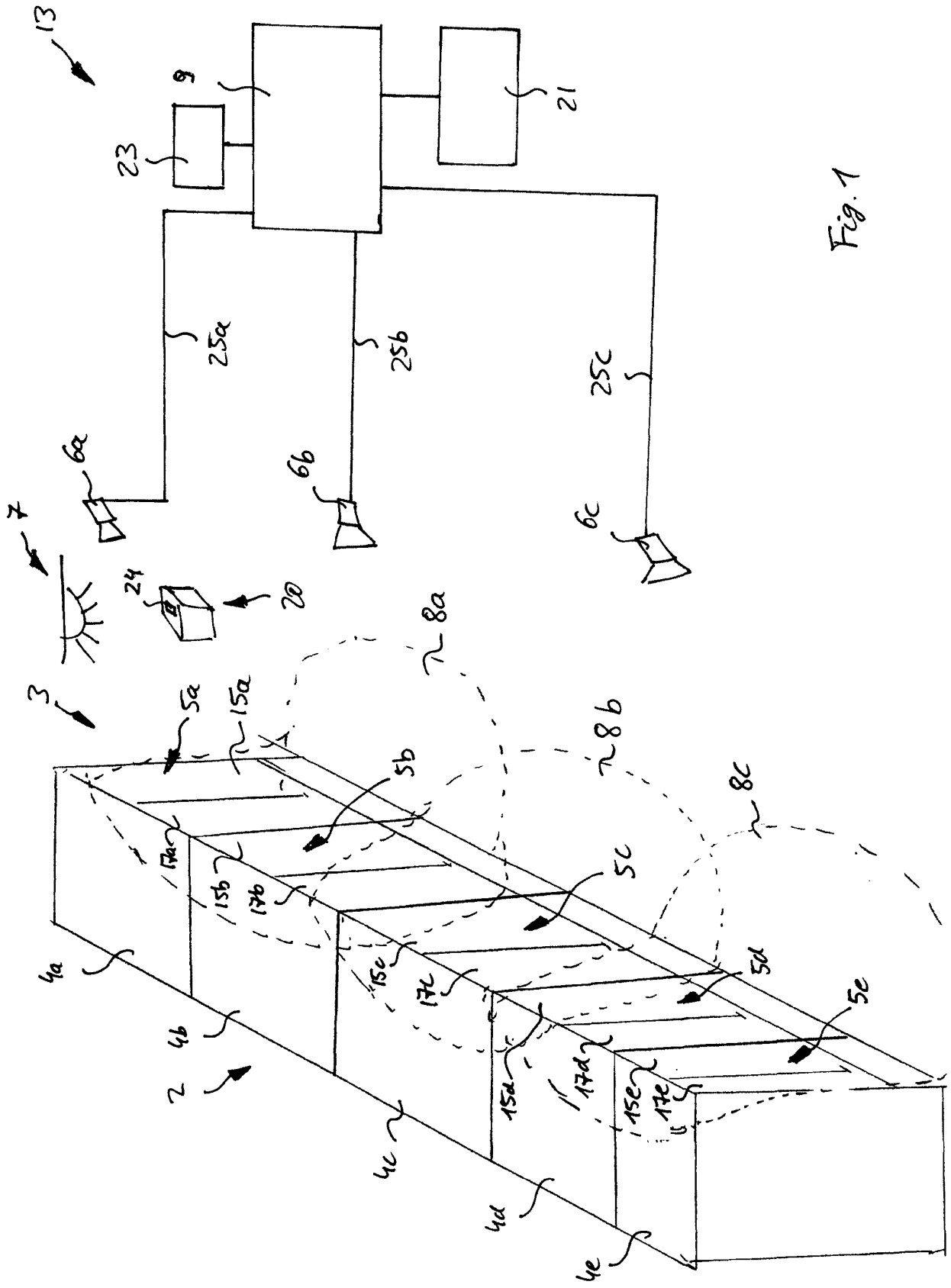

Fig. 1

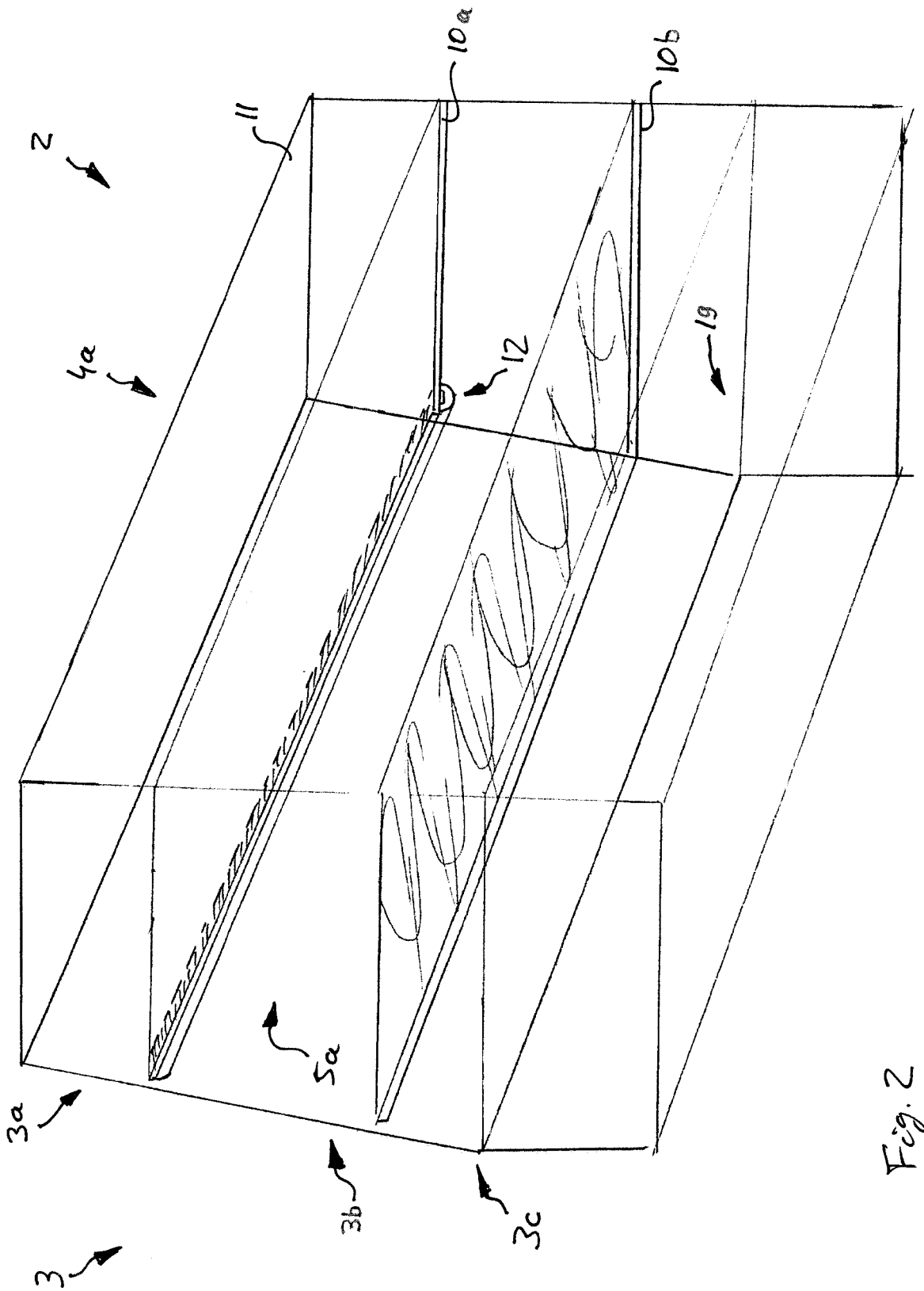

Fig. 2

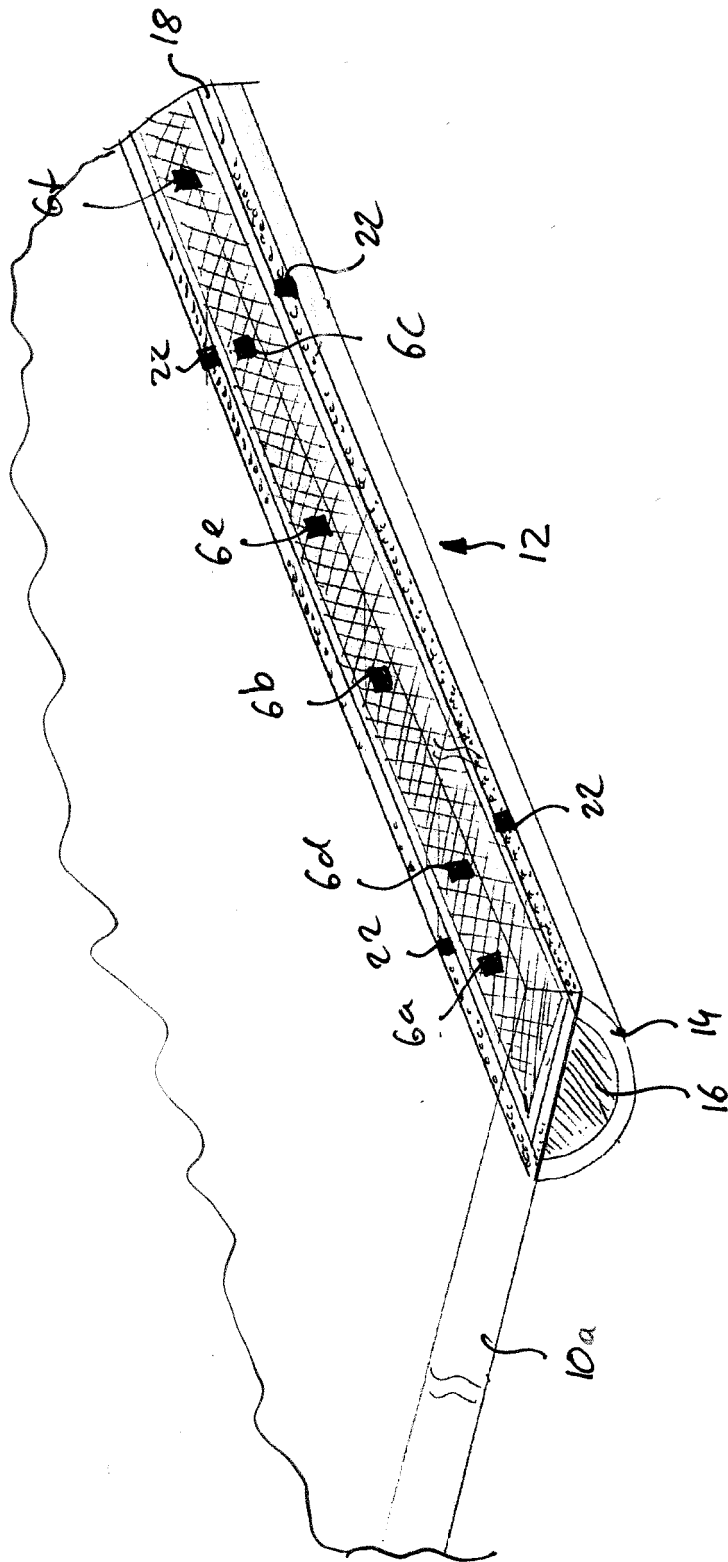

Fig. 3

REFERENCES CITED IN THE DESCRIPTION

This list of references cited by the applicant is for the reader's convenience only. It does not form part of the European patent document. Even though great care has been taken in compiling the references, errors or omissions cannot be excluded and the EPO disclaims all liability in this regard.

Patent documents cited in the description

- JP 2001183051 A [0005]