

(19) **DANMARK**

(10) **DK/EP 2909828 T3**



(12) **Oversættelse af
europæisk patentskrift**

Patent- og
Varemærkestyrelsen

-
- (51) Int.Cl.: **G 09 F 1/14 (2006.01)** **G 09 F 7/12 (2006.01)**
- (45) Oversættelsen bekendtgjort den: **2019-07-29**
- (80) Dato for Den Europæiske Patentmyndigheds bekendtgørelse om meddelelse af patentet: **2019-04-24**
- (86) Europæisk ansøgning nr.: **13779727.0**
- (86) Europæisk indleveringsdag: **2013-10-02**
- (87) Den europæiske ansøgnings publiceringsdag: **2015-08-26**
- (86) International ansøgning nr.: **EP2013002957**
- (87) Internationalt publikationsnr.: **WO2014060067**
- (30) Prioritet: **2012-10-18 BE 201200707** **2013-02-11 BE 201300095**
- (84) Designerede stater: **AL AT BE BG CH CY CZ DE DK EE ES FI FR GB GR HR HU IE IS IT LI LT LU LV MC MK MT NL NO PL PT RO RS SE SI SK SM TR**
- (73) Patenthaver: **CREA N.V., Grijspeerdstraat 71, 8830 Gits, Belgien**
- (72) Opfinder: **LASSEEL, Sammy, Kapellenhoek 21, B-9340 Smetlede, Belgien**
- (74) Fuldmægtig i Danmark: **Dennemeyer & Associates S.A, P.O. Box 700425, DE-81304 Munich, Tyskland**
- (54) Benævnelse: **FORSKYDELIGT INFORMATIONSSYSTEM OG FREMGANGSMÅDE TIL FREMSTILLING OG BRUG AF INFORMATIONSANORDNINGEN I SYSTEMET**
- (56) Fremdragne publikationer:
WO-A1-02/36360
CH-A5- 692 229
GB-A- 2 349 887
GB-A- 2 429 820
US-A- 3 422 556
US-A- 3 440 750
US-A- 4 917 342
US-A- 6 136 392

DESCRIPTION

[0001] The invention relates to a movable in particular a slideable information device with a ground support for placement on a supporting surface. The device also comprises an upright element that is connected to the ground support, which contains a baseplate, for example. This upright element then bears information, printed or otherwise, for example an advertisement, instructions or publicity message. The invention concerns also a very useful method for manufacturing such a device and assembling it from its elements, comprising ground support and upright element.

TECHNICAL FIELD, STATE OF THE ART

[0002] Such information devices are generally known. For the most part, the ground support is a movable stand of plastic, wood or metal, with an integrated upright holder in which or on which a medium, in plate or sheet form for example, for the intended informative message can be slid or stuck. This design makes the device considerably expensive. Sometimes the device can also be too easily knocked over such that the intended function as a medium for a message no longer attracts attention until the device is stood or put upright again.

[0003] It is known that a horizontal plate, for example a glass plate, with a flat, very even and smooth bottom surface can be slid over and adjustably attached by suction to a very even and flat top surface of a supporting horizontal (glass) plate. The perfect contact between the two plates prevents air being able to penetrate into the mutual contact zone close to the outside edge of this zone. A vacuum or sub-pressure is, as it were, created between the (glass) plates. The atmospheric pressure on the free outer surfaces of the two plates thus keeps them firmly pressed together. Due to their smooth contact surface, the plates can slide somewhat over one another without detaching from one another. In other words, the vacuum area slides with the contact surface.

[0004] US patent 3422556 relates to an information device with a magnetic base plate and an upright holder for carrying an information marker for use on automobiles or other magnetic objects.

[0005] On the other hand, a non-adjustable information medium in plate form according to an analogous vacuum adhesion principle is known from US 6136392. This information medium comprises a partially convex outer surface and a partially concave inner surface, and a cavity between this inner surface and the supporting surface on which the medium must be attached. By pressing the flexible convex part of the medium centrally onto the supporting surface, the air there is driven out of this cavity past the outside edges of the contact surface with the supporting surface. In this way, a vacuum area is created in this contact surface. This vacuum area ensures that the information medium is firmly, but not adjustably, affixed to the supporting surface analogous to a suction pad effect. For the rest, this information medium has no upright

element.

[0006] GB 2429820 discloses a suction cup mounted sign for a vehicle.

[0007] The purpose of the invention is to provide a movable information device with a ground support and with an upright element whereby the device does not fall over when the upright element is collided with transversely. In other words, the ground support must not detach from its supporting surface upon such a collision. The invention further aims at keeping the device readily able to slide over the supporting surface for the purpose of its versatile usability. Thus the device must for example not be attached immovably or rigidly to the supporting surface. Moreover, according to a further objective, the device preferably does not completely detach from the underlying supporting surface when it is gripped at the top of its upright element and then it is attempted to slide it over the supporting surface, or if a person wants to wrench it away in a direction almost perpendicular to the supporting surface.

[0008] Due to its typical spatial structure with a ground support and an upright element, it is difficult to package and transport the information device in an easy and compact manner. This is a great disadvantage because generally a large number of devices have to be packaged and shipped together to the user. It is thus in addition a purpose of the invention to provide a manufacturing method that enables an easy packaging and transportation of the movable information devices. It is at the same time a purpose of that method to allow an easy manual, semi-automatic or automatic assembly of the movable information device from its components. In particular it is a purpose to provide a manufacturing method that enables the ground support and the upright element components to be manufactured together at the same time so that they can be assembled in view of a compact packaging.

BRIEF DESCRIPTION OF THE INVENTION

[0009] According to the invention, these objectives are met in a surprising way by a movable, in particular sliding, information device for placement and sliding on (over, in contact with) an even and flat supporting surface. Embodiments of the present invention include a system for displaying information, the system comprising a sliding device and a supporting surface. As a ground support, the device consists of a baseplate with a flat and even surface on its underside. An upright element is fastened to the top surface of the baseplate via a base. According to the invention, it is important that the base allows elastic bending of the upright element back and forth from an unloaded rest position A to a transversely loaded oblique position B as explained hereinafter.

[0010] The use of an information device on a supporting surface is described according to an aspect of the present invention, for preventing detachment and providing sliding of the device on the supporting surface.

[0011] According to another important aspect of the invention, the base of this upright element

comprises a limited fastening zone with the baseplate as explained hereinafter. This fastening zone runs substantially parallel to the upper surface of the baseplate. The distance "b" between the edge of this fastening zone of the base and the outside edge or peripheral edge of the baseplate must not be less than 2.5 cm anywhere according to the invention.

[0012] According to a further aspect of the invention, the upright element is preferably fastened almost in, or facing the centre of the baseplate. The upright element will also often be fastened almost perpendicular to the said top surface.

[0013] For the rest, the invention provides a series of other important preferred characteristics of the device as contained in the added claims and further explained hereinafter.

[0014] With regard to the favourable method of manufacturing the movable information device the objectives of providing an easy assembly from its components, enabling a compact packaging and transportation, the method comprises the application of printing on an elastically bendable substrate in plate form, and the cutting or stamping (punching) out of a series of segments from that substrate. The outer periphery of these segments defines the components bordering each other for the device such as the upright element, base, an extension piece of that base and the baseplate as is explained hereinbefore and hereafter.

[0015] According to an important characteristic of the method, the dividing line between that extension piece and the baseplate is preferably not entirely cut through during this cutting operation. A suitable fixing means is also applied onto the said base. Then the baseplate is folded over from the segment by 180° along the said dividing line, preferably the incompletely cut dividing line. The baseplate is thereby pressed against the base onto the applied fixing means for a strong and durable attachment there.

[0016] The upright element is now folded back from this flat laminated structure by 90° (perpendicularly) along the folding line between the base and the upright element. In this way, the intended spatial structure for the information device is set up, with its baseplate and its upright element durably bonded to it.

[0017] In practice, the flat segments cut out in series will often be immediately stacked on one another to be able to compactly ship them to the user, for example after the baseplate has been folded over from the segment by 180° and strongly attached to the base by adhesive.

[0018] After unstacking these thus obtained, laminated, primarily flat structures, the user can perpendicularly fold out the upright element for each information device to be set up. After setting up, the perpendicular position of the upright element can, if desired, be additionally locked by folding out at least one suitable prop element that can be folded out from the upright plate.

BRIEF DESCRIPTION OF THE DRAWINGS

[0019] A number of embodiments of the movable information device and aspects of a favourable method to manufacture them according to the invention will now be described on the basis of accompanying drawings. It goes without saying that the protection is not limited to these embodiments. They are only to be taken as examples for clarification of the scope of protection claimed in the claims.

Figure 1 is a perspective sketch of a movable information device on an even supporting surface according to the invention.

Figure 2 schematically shows a cross-section of a detail of the fastening zone between the base and baseplate when the information device is in rest position A.

Figure 3a and 3b show a cross-section of a detail of the fastening zone between the base and the baseplate in the event of a transverse load on the upright element in an oblique position B.

Figure 4 sketches an embodiment with an extension piece that connects to the base.

Figure 5a shows a front view of a segment cut out from a substrate.

Figure 5b shows a cross-section, according to line II-II of figure 5a.

Figure 6 shows a cross-section, according to line II-II of figure 5a, of a segment in a folded state for packaging.

Figure 7 sketches a stack of the folded segments according to figure 6 in their packaging.

Figure 8 illustrates a cross-section according tot line II-II of figure 5a after folding out the upright element by 90°.

Figure 9 is a perspective view of an embodiment of a movable device during a folding step of its components.

DETAILED DESCRIPTION

[0020] In the arrangement according to figure 1, the information device 1 with its baseplate 3 is set down on the even and flat, possibly smooth, horizontal top surface as a supporting surface 2. This even supporting surface can be a table top, for example, if necessary with a ground or polished surface of wood or veneer, plastic, glass, natural stone, marble, concrete or metal. A substrate with an even and smooth topcoat, for example a coat of lacquer, can also be used as a supporting surface 2. The baseplate 3 also has a pronounced even and flat, possibly smooth, underside (bottom) surface 4 that rests on the table top and whereby the underside surface 4 makes perfect contact with the supporting surface 2 without enclosing an air film. The contact zone thus behaves as a sub-pressure or vacuum area while the top surface of the

baseplate 3 is exposed to atmospheric pressure. As a result, this baseplate with the device 1 can only slide over the supporting plate 2, and also without detaching from it.

[0021] The upright element 5 in figure 1 and figure 2 is fastened in its vertical rest position A on the baseplate 3 by means of a base 6, for example by inserting a fastening zone 7 in the form of a strong adhesive for example (Loctite or a double-sided adhesive tape). The baseplate lays thus completely flat on the supporting surface 2. An information message 14 (fig. 4) can be applied, for example printed, to one or both sides or walls of the upright element 5. The printing will then preferably be done before the baseplate and upright element are fastened together. Analogously information messages can be applied to the baseplate, at least on its topside. If desired, separate, possibly removable, extra information media 13 can be affixed on the baseplate 3 and/or on the upright element 5. These information media 13 may be three-dimensional objects. If desired, the upright element itself can have a three-dimensional form above its base.

[0022] The baseplate 3 is sufficiently rigid but can be somewhat flexible, for example a plastic. It will in general at least contain plastic in its even underside surface 4. A perfectly flat PVC sheet is preferable. Its thickness is between 0.2 mm and 0.8 mm, and preferably between 0.35 mm and 0.5 mm for the purpose of a suitable flexibility and pliability. The bottom surface 4 of the baseplate has a surface greater than 30 cm², and preferably greater than 40 cm², and can be up to 1 m² depending on the desired volume of the information device. The baseplate 3 can be square, circular, oval or polygonal. It can also have a more irregular periphery. The base 6 does not necessarily have to be fastened close to the centre of the baseplate 3; in particular this is not necessary for a baseplate with an irregular periphery. The baseplate 3 preferably has rounded corners 17.

[0023] The upright element 5 is preferably also a flexible, in particular elastically bendable, PVC plate with the same thickness as the baseplate 3. This simplifies the manufacture of the device 1, as the baseplate 3, base 6 and upright element 5, after applying the desired printing, can all be punched from the same PVC plate. The upright element 5 can also have a pronounced decorative form, as sketched in figure 1.

[0024] The base 6 can be rectangular, preferably also with rounded outside corners 17. It can also have the shape of a semicircle (half-moon), for example. A conventional, strip-shaped substrate covered with adhesive on either side can be used as a strong adhesive in the fastening zone 7.

[0025] Figure 2 also sketches in dotted lines a position in which the device 1 is gripped close to the top edge of its upright element 5 and is lifted upwards with a force according to arrow 16. As a result, the flexible baseplate can be lifted up somewhat just below the fastening zone 7 such that a (temporary) minimal, enclosed space 15 can occur above the supporting surface 2. This space 15 possibly causes a somewhat stronger sub-pressure there and thus even greater resistance to the detachment of the baseplate 3 from the supporting surface, for example while horizontally sliding the device 1 over the supporting surface. In order to finally remove the

information device 1 from its supporting surface 2, the device 1 can be slid across it by its baseplate until a part of its peripheral edge 19 is past a free edge of the supporting surface 2. In this way, the sub-pressure or vacuum is then neutralised or removed.

[0026] Figures 1 and 2 also illustrate the important characteristic of the invention regarding the distance "b" from the outside edge 19 of the baseplate 3 to the peripheral edge 18 of the fastening zone 7 with the base 6. According to the invention, this distance "b" must not be less than 2.5 cm anywhere, but preferably greater than 3 cm. The distance "b" can also be markedly larger than 3 cm so that the minimal space 15 can remain relatively small, even with devices 1 with a substantially large baseplate 3 (for example greater than 100 cm²). The fastening zone 7 will preferably have an area of at least 1 cm². In each case the space 15 must not extend beyond the supporting surface 2 to a boundary where an outside edge 19 of the baseplate 3 is lifted up from the supporting surface. This would mean a leak for the vacuum whereby air could flow in via this outside edge of the contact surface between the baseplate 3 and the supporting surface 2 into the space 15. The baseplate 3 would then immediately detach from the supporting surface.

[0027] Figure 3a, and figure 3b show two analogous positions in which the upright element 5 is pushed in an oblique position along a transverse direction B: once to the right and once to the left. The pressure in the direction B can be the result of a wind load on the device 1, for example. If the bending force B is now stopped in reaction, the flexible, elastically bendable upright element 5 will immediately elastically return to its rest position A, without the baseplate 3 having the opportunity to detach from the supporting surface 2.

[0028] A strong connecting zone 8, for example a substantially L-shaped profile, between the base 6 and upright element 5 supports and also fosters the realisation of the intended elastic bending for the element 5 when it is loaded in a transverse direction B and when this load is then removed. The strong connecting profile 8 can be realised, for example, with an upright element 5 of a thermoplastic by hot-folding its base 6 into a practically perpendicular plastic shape, for example via an intermediate zone 9 between the base 6 and upright element 5. This zone 9 can approximate the upright leg of an L profile, for example around its longitudinal axis 10 (as a folding line) in the intermediate (transitional) zone 9. This is also shown in figures 1. In figure 3a and in figure 4, the zone 9 comprises an advantageous division of the deformation over two parallel folding lines 10. This can foster a durable resistance of the intermediate zone to repeated bending loads. The folding lines 10 can be designed as a longitudinal groove or notch in the lower part of the upright element 5.

[0029] The design according to figure 4 concerns the possible addition of an extension piece 12 to the base 6 close to its outside edge 11, and which, if need be, runs almost parallel to the baseplate 3. The extension piece always covers the baseplate 3 at least in part. In this way a split-shaped storage space is created between the baseplate and extension piece 12 for the insertion of one document or another, such as a receipt. The extension piece 12 can, if desired, protrude past the outside edge 19 of the baseplate. This does not impede the

operation of the movable device 1.

[0030] As sketched in figure 5a, the starting product for the manufacture of the information device 1 according to the invention is preferably an elastically bendable substrate 20 in plate form with an even and flat underside (bottom) surface 4. It can be a PVC or a polyethylene plate, for example. This substrate 20 is first provided with the desired printing 14 (fig. 4) at the preselected places on one or both flat sides. Then the appropriate segments 21 are cut or punched out. The peripheral line 22 of these segments thereby defines the components of the device that border each other: the upright element 5, its base 6, an extension piece 12 against the base and finally the baseplate 3.

[0031] The dividing line 23 between the baseplate 3 and the extension piece 12 can thereby be almost completely cut through. The length of the uncut section 28 in the dividing line 23 is then preferably short because this facilitates the subsequent folding over of the baseplate 3 by 180° along this dividing line 23. This short length of the section 28 can even be limited to one point zone 29, but preferably to two such point zones. The baseplate 3 and the extension piece 12 are then thus only connected at least at one, or preferably at least two, point zones 29. As a result, the precise folding over of the baseplate 3 by 180° along the dividing line, and keeping it in its correct position, can be readily done. Only after the end of the folding operation by 180° - and preferably after the strong bonding onto the base 6 - will the point-shaped connecting zones 29 be readily broken up if desired. In this way, a laminated flat structure 25 is obtained, as shown in figure 6.

[0032] As a result, a very advantageous effect also occurs for the flat structure 25 and for the device 1 in its folded open position. Indeed, a flat split 30 occurs between the top side 31 of the folded baseplate 3 and the outside edges of the extension piece 12 extending across it, as shown in figure 7. Temporary papers, such as business cards, napkin edges, order forms or bills can be clamped in these splits, if desired.

[0033] In stead of a cut out dividing line 23, the embodiment of a segment 21 in figure 5b with a similar cross-section according to line II-II (in fig.5a) shows a groove or notch 36 at the place of that cut out dividing line 23. This groove will preferably extend along the dividing line 23 and along the entire width of the baseplate 3. Such groove 36 is to be considered according to the invention as a kind of a dividing line 23 that is not fully cut out. The presence of such groove 36 can foster an easy alternative bending and folding over of the baseplate 3 along the dividing line 23.

[0034] The cutting out of the series of segments 21 from the substrate 20, the successive application of the fixing means 24 to the bases 6, the folding over of the baseplate by 180° along the dividing line 23, and the strong bonding of the baseplate 3 to the bases 6 can be done by machine in a continuous operating line. Preferably a polyurethane or isocyanate glue is used as an adhesive part of the fixing means 24.

[0035] The strong and durable bond can be further assured by stacking a number of laminated

structures 25 on one another (figure 7) and, if desired, the stack, packaged or otherwise, can be kept under transverse pressure for a certain time.

[0036] The information device 1 in its folded open position according to figure 8 occurs by folding out the upright element 5, close to the folding line 10, by 90° from the laminated structure 25. In order to prevent this element 5 bending back from its straight upright position to a sloping position over time, a suitable prop element 27 can be folded out against the baseplate 3, for example along its folding line 33 in the upright element 5. Due to this measure, the upright position of the element 5 is locked. However, if the device is to be returned to its laminated flat structure 25 for more or less easy stacking, then the prop element 27 can be bent back along its folding line 33 in the plane of the element 5, and this element is then bent back against the baseplate 3. The prop element 27 shown in figures 5a and 8 thus approximates a right-angled triangle, for example, the sloping side 34 and bottom edge 35 of which are made when punching out the segments 21.

[0037] The automatic bonding (in a continuous line) or semi-automatic bonding of the baseplate 3 onto the base 6, for the realisation of the laminated flat structure 25, can proceed as follows. The successive segments 21 can be punched from the substrate 20 with the partially cut dividing line 23 between the baseplate 3 and the extension piece 12 in a first stage in a transport line, for example comprising a continuous conveyor belt. At the same time, the cutting of the sloping side 34 and bottom edge 35 of the prop element 27 is done. In the next stage, the appropriate adhesives 24 are applied in the successive bonding zones (against the bases 6) passing by. Further on in the transport line, the successive baseplates 3 are suitably gripped mechanically and/or pneumatically and folded over by 180° along the dividing line 23 on the extension piece 12 and onto the bonding zones with adhesive 24. They are sufficiently pressed on them for initial bonding. With this folding over of the baseplate 3 from the substrate 20, the surrounding substrate residue around the parts 12, 6 and 25 keeps these parts in the right position for further operations and transit through the transport line. Just before or during the removal and stacking of the already (somewhat) laminated structures 25, the surrounding edge residues of the substrate 20 are then removed for recycling, for example. If desired, the stack can be suitably compressed under pressure for further consolidation of the adhesives for a durable and accurately positioned attachment of each base 6 on its accompanying baseplate 3.

[0038] Finally, figure 9 illustrates an embodiment of the information device wherein the extension piece 12 is much larger than for example in figure 4 or figure 5a. Indeed the edges 37 can run parallel to the peripheral line 22 of the upright element 5 during punching out of the segments 21 from the substrate 20 (fig. 5a). In this manner the extension piece 12 can cover a much larger part of the baseplate 3 and so contribute to an extra protection of this baseplate, combined even with a more complete use of the available plastic present in the original substrate 20. At the same time, the flaps with edges 37 of the extension piece 12 offer extra space to insert in a removable way sheets, tags, cards in a larger split 30 than shown in fig. 5a.

[0039] The invention is of course not limited to the described embodiments of the claimed

information device and method. Many functional variants of the method stages and constructive variants of the information device, obvious to the person skilled in the art are conceivable.

REFERENCES CITED IN THE DESCRIPTION

This list of references cited by the applicant is for the reader's convenience only. It does not form part of the European patent document. Even though great care has been taken in compiling the references, errors or omissions cannot be excluded and the EPO disclaims all liability in this regard.

Patent documents cited in the description

- US3422556A [0004]
- US6136392A [0005]
- GB2429820A [0006]

FORSKYDELIGT INFORMATIONSSYSTEM OG FREMGANGSMÅDE TIL FREMSTILLING OG BRUG AF INFORMATIONSANORDNINGEN I SYSTEMET

Patentkrav

- 1.** Forskydeligt informationssystem, der omfatter en støtteoverflade (2) og en forskydelig informationsanordning (1) til placering og forskydelse på støtteoverfladen (2), hvor anordningen omfatter en bundplade (3) og et opretstående element (5), der er fastgjort til overfladen ved hjælp af en base (6), der muliggør elastisk bøjning af det opretstående element frem og tilbage fra en ubelastet hvileposition A til en tværgående, belastet skrå position B, og kendetegnet ved, at afstanden "b" mellem den periferiske kant (19) på bundpladen og den periferiske kant (18) på fastgørelseszonen eller -området (7) mellem basen (6) og bundpladen (3) ikke er mindre end 2,5 cm på noget sted, og at støtteoverfladen (2) omfatter en jævn og flad overflade, og at bundpladen omfatter en flad og jævn nederste overflade (4) på undersiden, således at den nederste overflade, når informationsanordningen placeres på støtteoverfladen, har perfekt kontakt med støtteoverfladen, uden at der indesluttet en lufthinde, til opnåelse af et område med undertryk, mens den øverste overflade udsættes for atmosfærisk tryk, når anordningen løftes opad fra støtteoverfladen (2).
- 2.** System ifølge krav 1, hvor det opretstående element (5) er fastgjort i det væsentlige vinkelret på den øverste overflade af bundpladen (3) og næsten på midten af overfladen på bundpladen (3).
- 3.** System ifølge krav 2, hvor bundpladen (3) er en PVC-plade, og dens tykkelse er mellem 0,20 mm og 0,80 mm.
- 4.** System ifølge krav 1, hvor arealet af den nederste overflade (4) af bundpladen (3) er større end 30 cm².
- 5.** System ifølge krav 1, hvor der er en indbyrdes forbindelseszone (8) mellem det opretstående element (5) og basen (6), der giver mulighed for den elastiske bøjning.
- 6.** System ifølge krav 1, hvor basen (6) på det opretstående element (5) og bundpladen (3) er føjet sammen i den indbyrdes forbindelseszone (7).
- 7.** System ifølge krav 1, hvor én eller flere separate ekstra informationsmedier (13) er tilføjet eller aftageligt tilføjet på bundpladen (3) og/eller det opretstående element (5).

8. System ifølge krav 3, hvor det opretstående element (5) er en PVC-plade med samme tykkelse som bundpladen (3).

9. System ifølge krav 1, hvor det opretstående element (5) omfatter et støtteelement (27), der kan foldes ud mod bundpladen (3).

10. System ifølge ethvert af de foregående krav, hvor den forskydelige informationsanordning (1) yderligere har et udvidelsesstykke (12) til basen (6), der er tæt på dens udvendige kant (11), og som dækker bundpladen (3) i det mindste delvist, hvor der er skåret helt igennem en skillelinje (23) mellem bundpladen (3) og udvidelsesstykket (12).

11. Fremgangsmåde til fremstilling af den forskydelige informationsanordning (1) i systemet ifølge krav 1, idet fremgangsmåden omfatter udskæring af en serie segmenter (21) fra et elastisk bøjeligt substrat (20) i pladeform, der er dækket af tryk (14), hvor den ydre omkreds (22) definerer komponenterne i anordningen (1), der grænser op til hinanden som f.eks. det opretstående element (5), basen (6), udvidelsesstykket (12) og bundpladen (3), samt

- hvor skillelinjen (23) mellem udvidelsesstykket (12) og bundpladen (3) ikke skæres ud i sin fulde længde

- hvor der anvendes midler til fastgøring (24) på basen (6), og

- hvor bundpladen (3) foldes over fra segmentet (21) med 180° langs skillelinjen (23) og sammenføjes mod basen (6) på midlerne til fastgøring (24), og

- hvor det opretstående element (5) foldes tilbage med 90° langs foldelinjen (10) mellem basen (6) og det opretstående element (5).

12. Fremgangsmåde ifølge krav 11, hvor segmenterne (21) efter udskæring stables fladt oven på hinanden og pakkes, hvor midlerne til fastgøring (24) anvendes efter afstabling.

13. Fremgangsmåde ifølge krav 11, hvor midlerne til fastgøring (24) efter udskæring anvendes på basen (6) på hver af segmenterne (21), og derefter foldes den ledsagende bundplade (3) over med 180° og føjes sammen med basen, hvorefter de derved opnåede, laminerede og primært flade strukturer (25) stables til bundtning i midler til emballering 26.

14. Fremgangsmåde ifølge et af kravene 11 til 13, hvor der efter tilbagefoldning af det opretstående element (5) med 90° langs foldelinjen (10) foldes et støtteelement, der kan foldes ud, (27) fra det opretstående element (5) for at låse dette opretstående element (5) i den opretstående stilling.

15. Brug af den forskydelige informationsanordning (1) i systemet ifølge krav 1 på en flad og jævn støtteoverflade (2), ved at komme i kontakt med den flade og jævne nederste overflade (4) på bundpladen (3) i anordningen med støtteoverfladen (2) uden at indeslutte en lufthinde,

hvorved der opnås et område med undertryk i kontaktzonen, når anordningen løftes opad fra støtteoverfladen (2), mens den øverste overflade på bundpladen (3) udsættes for atmosfærisk tryk, hvilket tillader den forskydelige informationsanordning (1) at glide på støtteoverfladen (2) og forhindre adskillelse fra den.

DRAWINGS

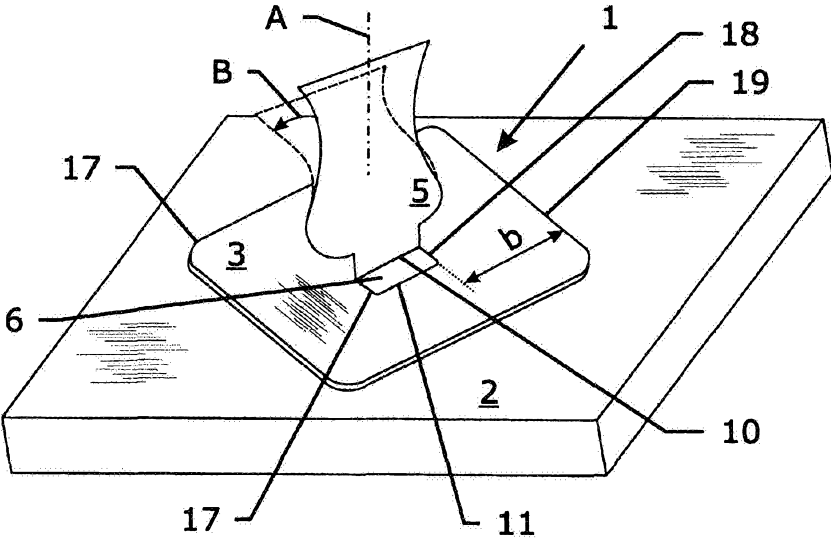

Fig. 1

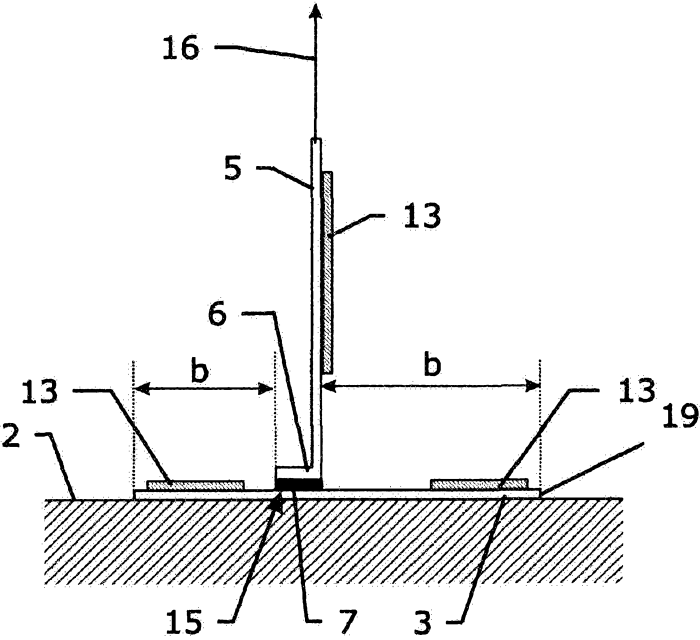

Fig. 2

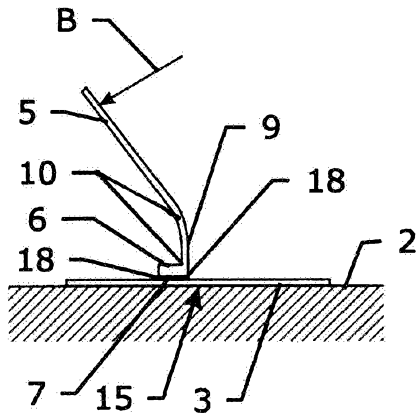

Fig. 3a

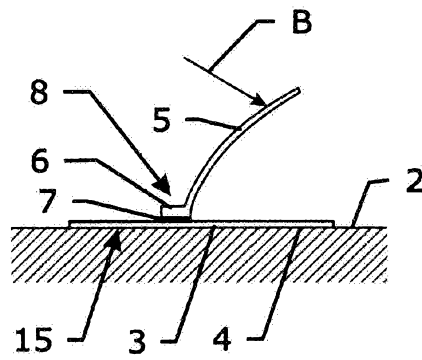

Fig. 3b

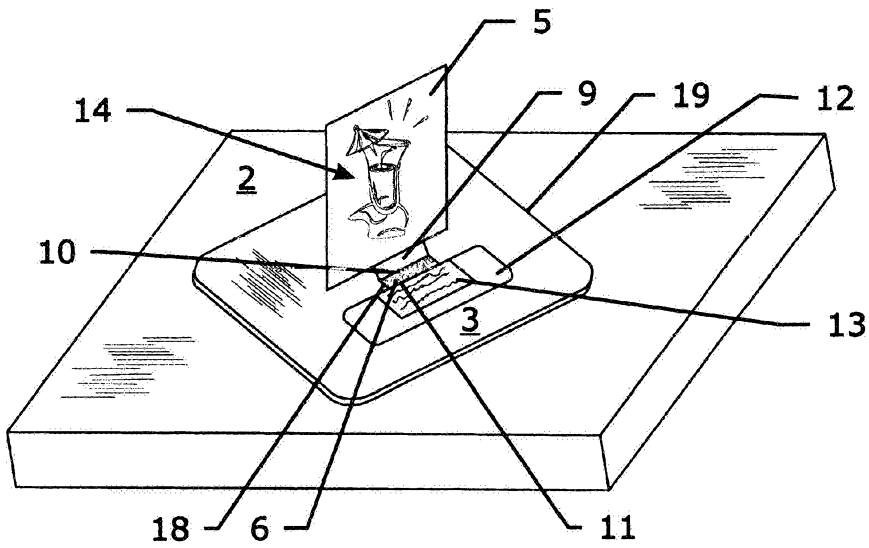

Fig. 4

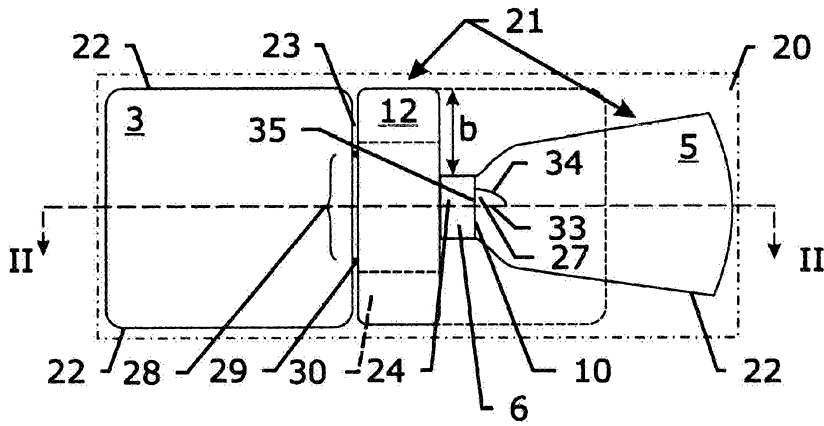

Fig. 5a

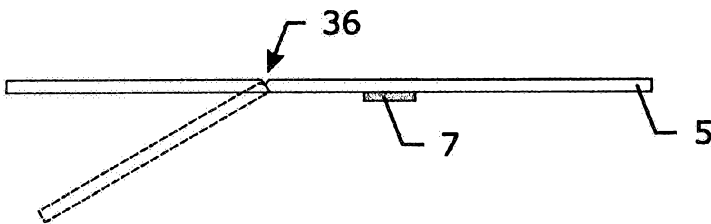

Fig. 5b

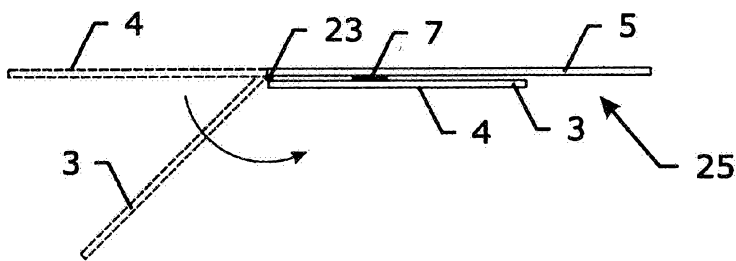

Fig. 6

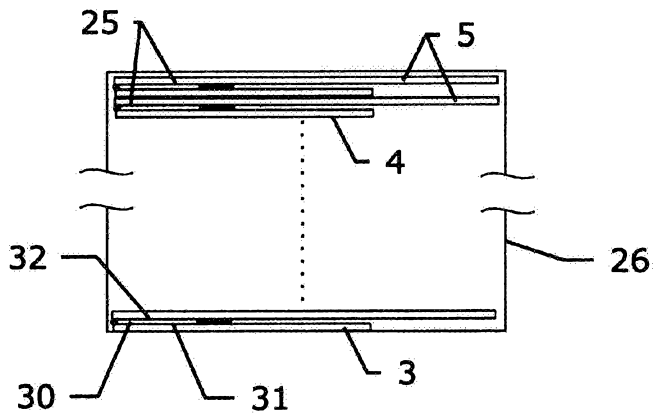

Fig. 7

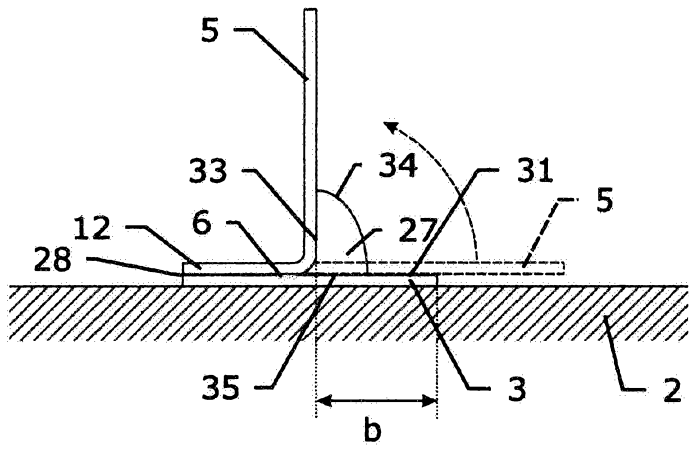

Fig. 8

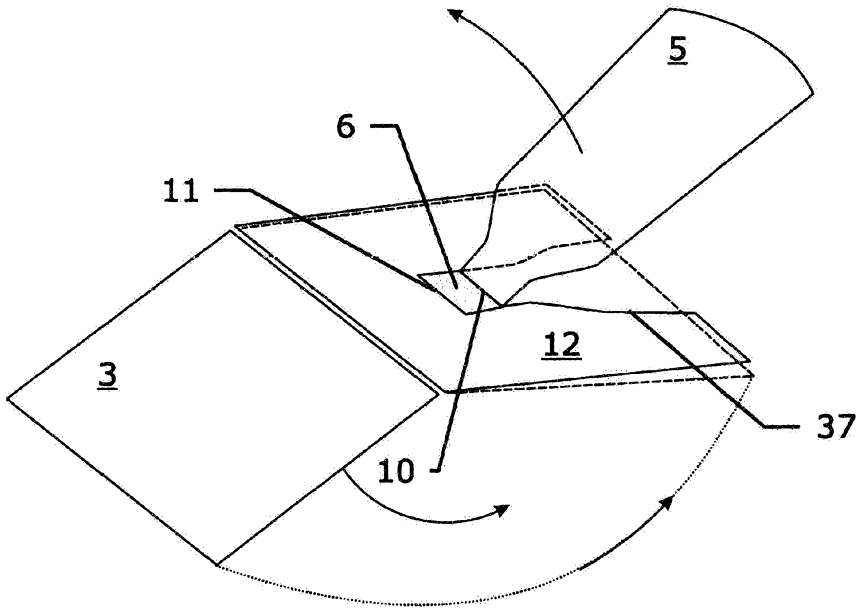

Fig. 9