

(No Model.)

2 Sheets—Sheet 1.

E. T. WRIGHT.  
STEAM ROAD ROLLER.

No. 524,628.

Patented Aug. 14, 1894.

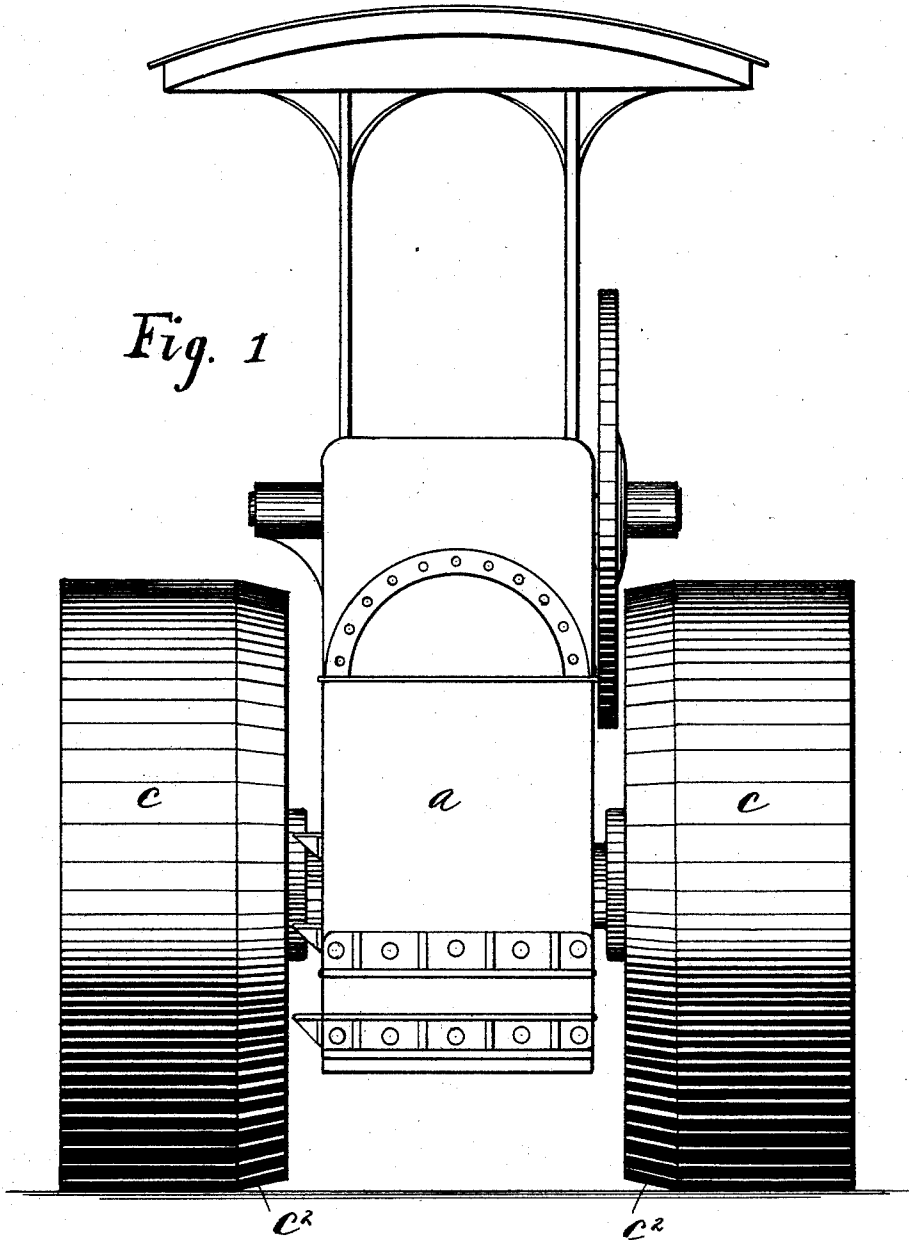

WITNESSES:

*Chas. J. Nichol*  
*Frank C. Barker*

INVENTOR

*Edward T. Wright*

BY

*Thos. J. Simpson*  
ATTORNEYS

(No Model.)

2 Sheets—Sheet 2.

E. T. WRIGHT.  
STEAM ROAD ROLLER.

No. 524,628.

Patented Aug. 14, 1894.

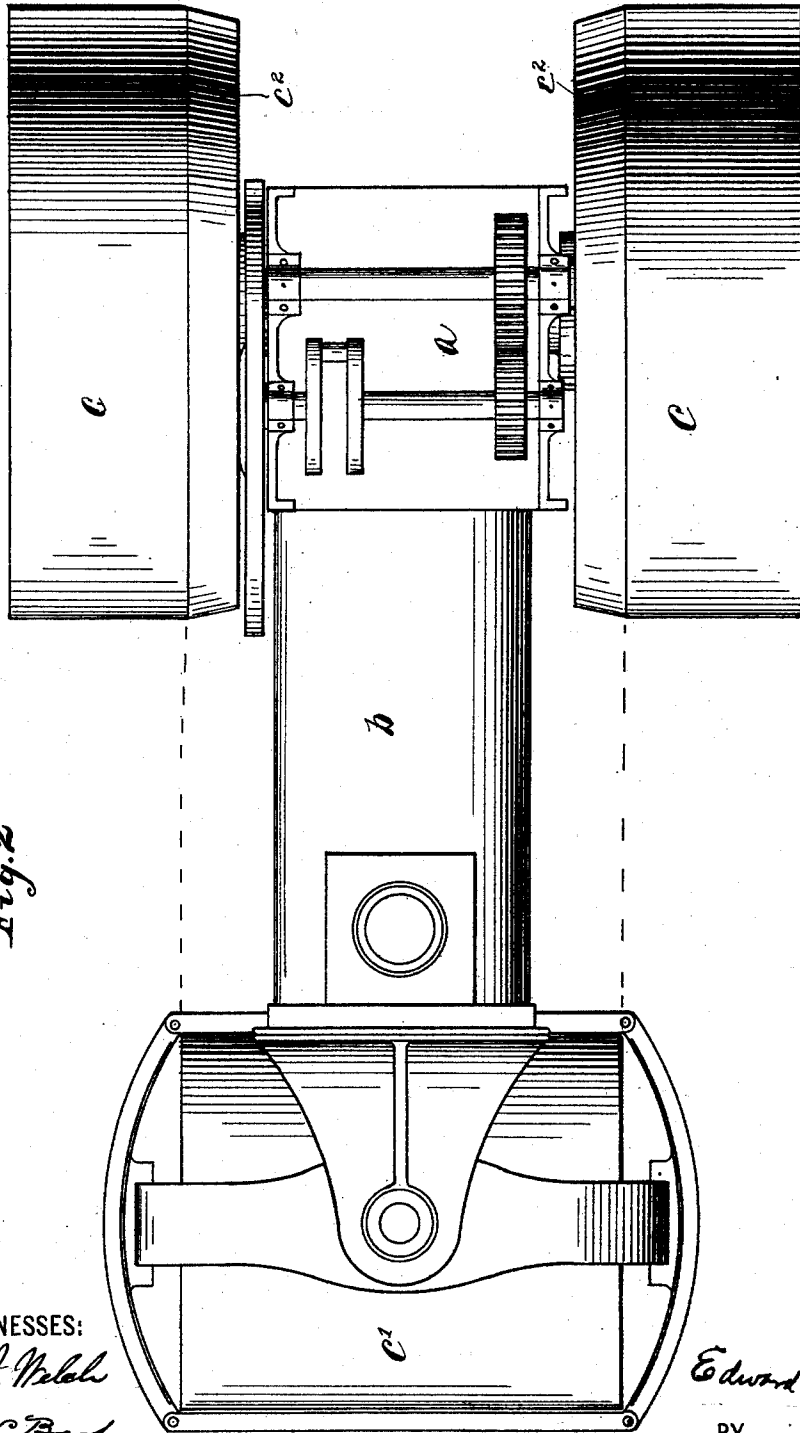

Fig. 2

WITNESSES:

*Chas. J. Nalah*  
*Frank C. Barker*

INVENTOR

*Edward T. Wright*

BY *Wm. H. Wood*  
ATTORNEYS

# UNITED STATES PATENT OFFICE.

EDWARD T. WRIGHT, OF SPRINGFIELD, OHIO, ASSIGNOR TO THE O. S. KELLY COMPANY, OF SAME PLACE.

## STEAM ROAD-ROLLER.

SPECIFICATION forming part of Letters Patent No. 524,628, dated August 14, 1894.

Application filed February 2, 1894. Serial No. 498,915. (No model.)

*To all whom it may concern:*

Be it known that I, EDWARD T. WRIGHT, a subject of the Queen of England, who have made oath of my intention to become a citizen of the United States, residing at Springfield, in the county of Clark and State of Ohio, have invented certain new and useful Improvements in Steam Road-Rollers, of which the following is a specification.

My invention relates to improvements in steam road rollers, and the object of my invention is to provide a novel construction of the driving and supporting wheels by which the operation of compressing the materials over which the roller passes is improved, and a greater degree of compactness secured under varying circumstances. I attain these objects by the constructions shown in the accompanying drawings, in which—

Figure 1 is a rear elevation of a machine embodying my invention, and Fig. 2 a plan view of the same.

Like parts are represented by similar letters of reference in the two views.

In the said drawings, *a* represents the main frame of a road roller; *b*, the boiler; *c*, the main driving wheels; and *c'*, the front or steering wheel or wheels. The driving wheels *c* are connected in any suitable manner to the motive power, which is preferably a steam engine supported on the boiler *b* in the usual manner, but not shown in the drawings. In all road rollers of this character the distribution of the weight of the machine is necessarily such that a larger proportion of the weight comes upon the driving wheels *c* than upon the steering wheel or wheels *c'*. In passing over loose materials, therefore, a greater compression is produced by the driving wheels than by the steering wheel or wheels. The result of this is, that, in the ordinary construction of the driving wheels, an elevation is left in the material over which the road roller has passed of a width corresponding to the width between the driving wheels, and, as the driving wheels are of a substantially uniform diameter throughout their width, the heavy compression at the inner edges of said driving wheels, not only produces a depression

of the material at this point, but also produces a slight elevation of the material adjacent to the inner edges of the wheel, which leaves an abrupt, elevated and ragged condition of the materials.

In my improved roller I provide the driving wheels with an extended portion *c<sup>2</sup>*, which is beveled inwardly, as shown, so that each of the wheels is of a smaller diameter at its inner periphery than at its outer, the main body of the driving wheel being of a substantially uniform diameter, as before. The width of the steering wheel or wheels is preferably such that their outer edges project beyond the extension *c<sup>2</sup>* so that the beveled portion *c<sup>2</sup>* of the driving wheels will, in the ordinary course of the roller, come within the tread of said steering wheel or wheels, as indicated by dotted lines in Fig. 2. The result of this construction is that in passing over loose materials, the elevation which occurs between the driving wheels, instead of being abrupt at each side, will be reduced by the beveled extended portions of the driving wheels on an incline, so that, instead of having the elevated and depressed portions adjoining each other by an abrupt and ragged line, these respective surfaces will be joined by an inclined surface, constituting a feathering edge. As the material is further reduced into a compact mass the compressing action of the driving wheels is increased insomuch as the surface over which the weight is distributed is decreased, since the straight portion only of the wheels will come in contact with the ground, the beveled portions being slightly elevated therefrom.

Having thus described my invention, I claim—

1. In a road roller, the combination with the main driving wheels, and a steering wheel or wheels, said driving wheels being provided with extended portions adapted to overlap the tread of said steering wheel or wheels, said extended portions being beveled, substantially as and for the purpose specified.

2. In a road roller, front and rear wheels, as described one set of said wheels being adapted to overlap the tread of the other set,

with the overlapping portions of one set beveled, substantially as and for the purpose specified.

3. In a road roller, main supporting and  
5 driving wheels, and a steering wheel or wheels, the tread of which occupies a space between said main wheels, said main wheels having a substantially uniform diameter as to those portions of which project beyond the tread of  
10 the steering wheel or wheels, and a reduced

and beveled portion for overlapping the tread of said steering wheel or wheels, substantially as and for the purpose specified.

In testimony whereof I have hereunto set my hand this 29th day of January, A. D. 1894. 15

EDWARD T. WRIGHT.

Witnesses:

OLIVER H. MILLER,  
CHAS. I. WELCH.