

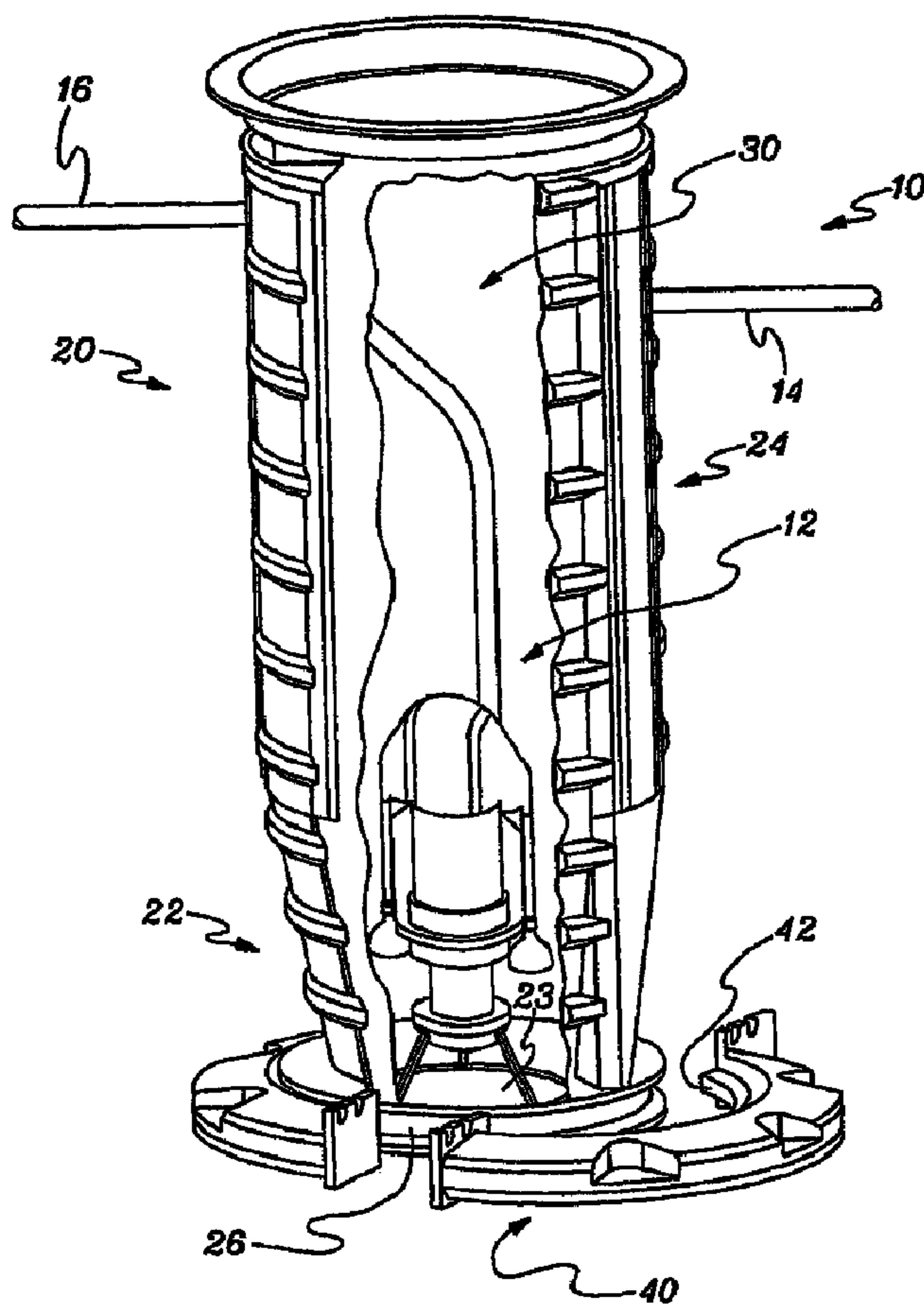

(86) Date de dépôt PCT/PCT Filing Date: 2005/08/01
 (87) Date publication PCT/PCT Publication Date: 2006/02/16
 (45) Date de délivrance/Issue Date: 2013/04/09
 (85) Entrée phase nationale/National Entry: 2007/02/01
 (86) N° demande PCT/PCT Application No.: US 2005/027280
 (87) N° publication PCT/PCT Publication No.: 2006/017448
 (30) Priorité/Priority: 2004/08/02 (US60/598,231)

(51) Cl.Int./Int.Cl. *E03F 5/02* (2006.01),
E02D 29/12 (2006.01), *E03F 11/00* (2006.01),
E03F 5/22 (2006.01)
 (72) Inventeurs/Inventors:
DALEY, PAUL J., US;
HENRY, CLARK, US;
HISGROVE, GRAEME, AU;
MASSEY, ADRIAN, AU
 (73) Propriétaire/Owner:
ENVIRONMENT ONE CORPORATION, US
 (74) Agent: CASSAN MACLEAN

(54) Titre : RESERVOIRS D'EAUX USEES ET SYSTEMES A POMPE BROYEUSE
 (54) Title: SEWAGE TANKS AND GRINDER PUMP SYSTEMS



(57) Abrégé/Abstract:

A sewage tank (20, 100, 200, 300) for use with a pump (12) such as a grinder pump to convey sewage. The sewage tank includes a container (21) having an upper portion (24) and a lower portion (22) defining a chamber (30) for containing the pump. The upper

(57) **Abrégé(suite)/Abstract(continued):**

portion has a generally constant cross-section and the lower portion has a tapered cross-section to reduce retained sewage. The upper portion and/or the lower portion includes a plurality of vertical ribs (25) and horizontal ribs (27) defining a plurality of recessed pockets (29). The lower portion of the sewage tank may also include an outwardly extending flange (40, 110) sufficiently sized so that soil may be backfilled around the bottom of the tank to prevent the tank from floating upward out of the ground due to its buoyancy under high ground water conditions. A sewage tank having a stepped flange (110) is also disclosed.

(12) INTERNATIONAL APPLICATION PUBLISHED UNDER THE PATENT COOPERATION TREATY (PCT)

(19) World Intellectual Property Organization
International Bureau(43) International Publication Date
16 February 2006 (16.02.2006)

PCT

(10) International Publication Number
WO 2006/017448 A1(51) International Patent Classification⁷: E03F 5/02, 5/22,
E02D 29/12, E03F 11/00Adrian [AU/AU]; 17 Palm Beach Crescent, Mount Wa-
verley, Victoria 3149 (AU).(21) International Application Number:
PCT/US2005/027280(74) Agent: PASCARELLA, David, A.; Heslin Rothenberg
Farley & Mesiti P.C., 5 Columbia Circle, Albany, NY
12203 (US).

(22) International Filing Date: 1 August 2005 (01.08.2005)

(25) Filing Language: English

(81) Designated States (unless otherwise indicated, for every
kind of national protection available): AE, AG, AL, AM,
AT, AU, AZ, BA, BB, BG, BR, BW, BY, BZ, CA, CH, CN,
CO, CR, CU, CZ, DE, DK, DM, DZ, EC, EE, EG, ES, FI,
GB, GD, GE, GH, GM, HR, HU, ID, IL, IN, IS, JP, KE,
KG, KM, KP, KR, KZ, LC, LK, LR, LS, LT, LU, LV, MA,
MD, MG, MK, MN, MW, MX, MZ, NA, NG, NI, NO, NZ,
OM, PG, PH, PL, PT, RO, RU, SC, SD, SE, SG, SK, SL,
SM, SY, TJ, TM, TN, TR, TT, TZ, UA, UG, US, UZ, VC,
VN, YU, ZA, ZM, ZW.

(26) Publication Language: English

(30) Priority Data:
60/598,231 2 August 2004 (02.08.2004) US(71) Applicant (for all designated States except US): ENVI-
RONMENT ONE CORPORATION [US/US]; 2773
Balltown Road, Niskayuna, NY 12309-1090 (US).

(72) Inventors; and

(75) Inventors/Applicants (for US only): DALEY, Paul,
J. [US/US]; 7 Linda Lane, Waterford, NY 12188 (US).
HENRY, Clark [US/US]; 305 Alexander Avenue, Scotia,
NY 12302 (US). HISGROVE, Graeme [AU/AU]; 400
Bay Street, Brighton, Victoria 3186 (AU). MASSEY,(84) Designated States (unless otherwise indicated, for every
kind of regional protection available): ARIPO (BW, GH,
GM, KE, LS, MW, MZ, NA, SD, SL, SZ, TZ, UG, ZM,
ZW), Eurasian (AM, AZ, BY, KG, KZ, MD, RU, TJ, TM),
European (AT, BE, BG, CH, CY, CZ, DE, DK, EE, ES, FI,

[Continued on next page]

(54) Title: SEWAGE TANKS AND GRINDER PUMP SYSTEMS

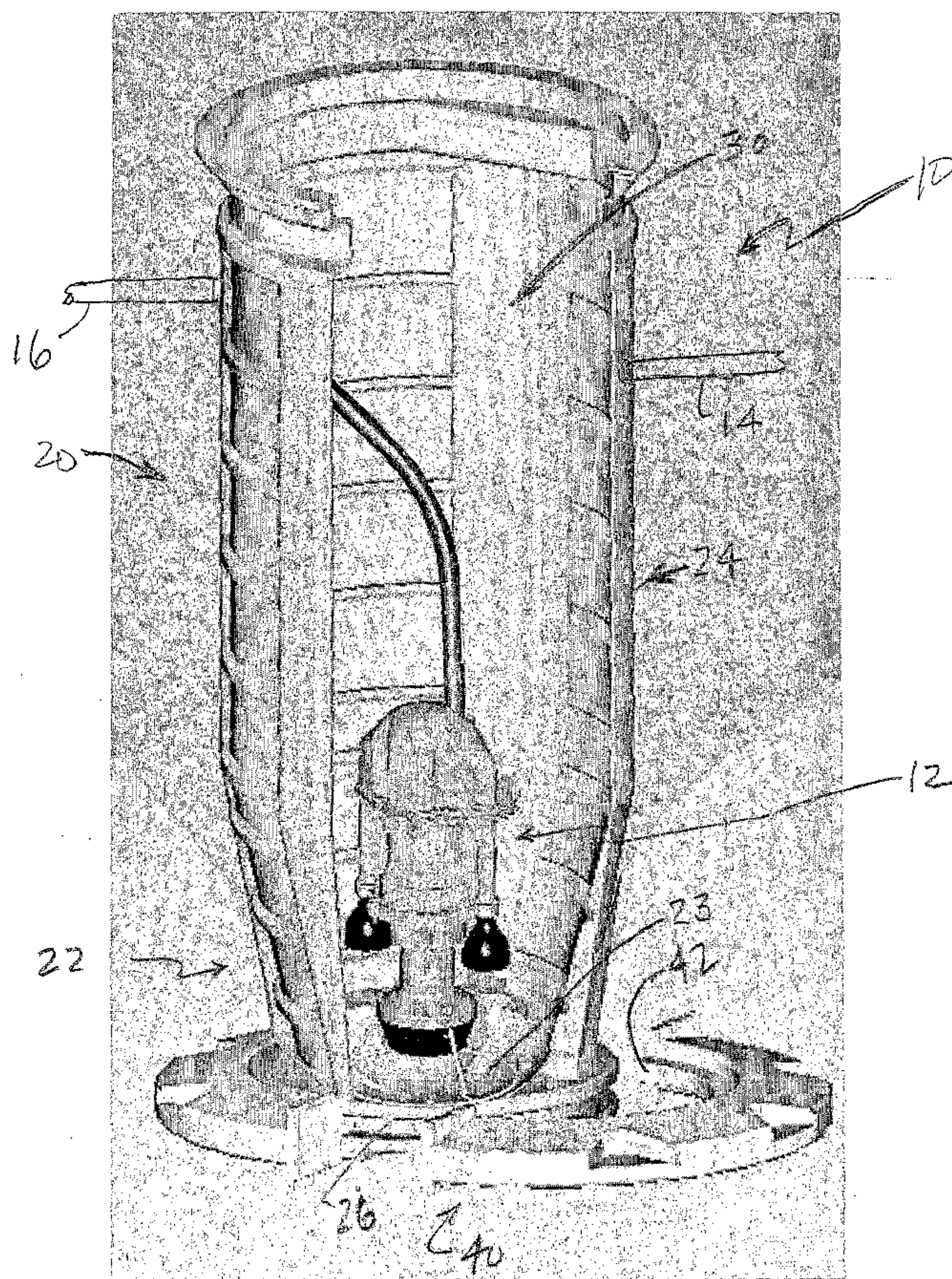
(57) Abstract: A sewage tank (20, 100, 200, 300)
for use with a pump (12) such as a grinder pump to
convey sewage. The sewage tank includes a container
(21) having an upper portion (24) and a lower portion
(22) defining a chamber (30) for containing the pump.
The upper portion has a generally constant cross-section
and the lower portion has a tapered cross-section to
reduce retained sewage. The upper portion and/or the
lower portion includes a plurality of vertical ribs (25)
and horizontal ribs (27) defining a plurality of recessed
pockets (29). The lower portion of the sewage tank may
also include an outwardly extending flange (40, 110)
sufficiently sized so that soil may be backfilled around
the bottom of the tank to prevent the tank from floating
upward out of the ground due to its buoyancy under
high ground water conditions. A sewage tank having a
stepped flange (110) is also disclosed.

WO 2006/017448 A1

WO 2006/017448 A1



FR, GB, GR, HU, IE, IS, IT, LT, LU, LV, MC, NL, PL, PT,
RO, SE, SI, SK, TR), OAPI (BF, BJ, CF, CG, CI, CM, GA,
GN, GQ, GW, ML, MR, NE, SN, TD, TG).

For two-letter codes and other abbreviations, refer to the "Guidance Notes on Codes and Abbreviations" appearing at the beginning of each regular issue of the PCT Gazette.

Published:

— *with international search report*

SEWAGE TANKS AND GRINDER PUMP SYSTEMS

[0001] (This paragraph intentionally left blank.)

FIELD OF THE INVENTION

[0002] This invention relates generally to sewage tanks, and more particularly, to sewage tanks for use with pumps such as grinder pumps.

BACKGROUND OF THE INVENTION

[0003] Grinder pumps are often used in low-pressure sewage systems for pumping sewage. A grinder pump includes a grinder mechanism for cutting or grinding solids or semisolid matter in the sewage being pumped. Grinding solids and/or semisolid matter in the sewage allows the resulting particulate effluent to be transferred using a pump through small diameter pipes without clogging.

[0004] Typically, conventional sewage tanks are installed by digging a hole, placing the tank in the ground, and then pouring concrete around the bottom of the tank. The concrete provides proper ballast to prevent the tank from floating upwardly and popping out of the ground due to its buoyancy under high ground water conditions.

[0005] There is a need for further sewage tanks and pump systems employing the same.

SUMMARY OF THE INVENTION

[0006] The present invention provides, in a first aspect, a sewage tank for use with a pump to convey sewage. The sewage tank includes a container having an upper portion and lower tapering portion defining a chamber for containing the pump. The lower tapering portion has a reduced size compared to the upper portion. The shape of the lowering tapering portion also provides for reduced sewage retention in the tank when emptied. The upper portion comprises a plurality of intersecting vertical ribs and horizontal ribs defining a plurality of recessed pockets, and the lower tapering portion comprising a plurality of intersecting vertical ribs and horizontal ribs defining a plurality of recessed pockets.

[0007] The present invention provides, in a second aspect, a sewage tank for use with a pump to convey sewage. The sewage tank includes a container having an upper portion and a lower tapering portion defining a chamber for containing the pump. The lower tapering portion has a reduced size compared to the upper portion. The lower tapering portion of the container comprises an integrally formed outwardly extending member. The lower tapering portion of the container and the outwardly extending member are configured to allow backfilling of the sewage tank so that the backfill provides sufficient ballast under high ground water conditions.

[0007a] The present invention provides, in another aspect, a sewage tank for use with a pump to convey sewage. The sewage tank includes a container having an upper portion and a lower tapering portion. The lower tapering portion of the container comprises an integrally formed outwardly extending member. The outwardly extending member is configured at two different heights to allow for multiple tanks to be nested together during shipping.

[0007b] The present invention provides, in another aspect, a sewage tank for use with a pump to convey sewage. The sewage tank includes a container, and a generally ring shaped member attachable around a portion of the container.

[0008] The present invention provides, in a third aspect, a sewage tank for use with a pump to convey sewage. The sewage tank includes a container for containing the pump, and the container comprises an upper portion having an inwardly extending portion for providing an opening for a vent.

[0009] The present invention provides, in a fourth aspect, a pump system which includes the above-described sewage tank and a pump such as a grinder pump disposable in the sewage tank.

[0009a] The present invention provides, in another aspect, a method of installing sewage tanks of the nature described previously.

BRIEF DESCRIPTION OF THE DRAWINGS

[0010] The subject matter which is regarded as the invention is particularly pointed out and distinctly claimed in the concluding portion of the specification. The invention, however, may best be understood by reference to the following detailed description of various embodiments and accompanying drawings in which:

[0011] FIG. 1 is a perspective view of one embodiment of a grinder pump system including a sewage tank in accordance with the present invention;

[0012] FIG. 2 is a perspective view, partially cutaway, of the grinder pump system of FIG. 1;

[0013] FIG. 3 is a perspective view, partially cutaway, of another embodiment of a grinder pump system including a sewage tank in accordance with the present invention;

[0014] FIG. 4 is a side elevational view of the grinder pump system of FIG. 3;

[0015] FIG. 5 is a side elevational view of a plurality of grinder pump systems of FIG. 3 nested together for shipping;

[0016] FIG.6 is a front elevational view of another embodiment of a grinder pump system including a sewage tank in accordance with the present invention;

[0017] FIG. 7 is a front elevational view, partially cutaway, of the grinder pump system of FIG. 6;

[0018] FIG. 8 is a front elevational view, partially cut away, of the grinder pump system of FIG. 7 along with a plurality of access ways;

[0019] FIG. 9 is a perspective view of one embodiment of a top of a sewage tank having an inwardly extending member for providing a vent in accordance with the present invention;

[0020] FIG. 10 is a front elevational view of another embodiment of a grinder pump system including a sewage tank in accordance with the present invention;

[0021] FIG. 11 is a left side elevational view of the grinder pump system of FIG. 10; and

[0022] FIG. 12 is a right side elevational view of the grinder pump system of FIG. 10.

DETAILED DESCRIPTION OF THE INVENTION

[0023] FIGS. 1 and 2 illustrate one embodiment of a low-pressure grinder pump wastewater disposal system 10 in accordance with the present invention for collecting, grinding, and pumping wastewater. System 10 generally includes a sewage tank 20 and a grinder pump 12 (FIG. 2).

[0024] System 10 is readily installable in the ground by connecting the system to a wastewater feed pipe 14 (FIG. 2), a wastewater discharge pipe 16 (FIG. 2), and an electrical power supply (not shown). The system may also be connected to or include a vent (not shown). The exemplary

wastewater disposal system provides a convenient, self-contained unit. In addition, the exemplary system is readily accessible and serviceable by a technician or a repair person.

[0025] Sewage tank 20 includes a container 21 having a lower portion 22 and an upper portion 24 which together define a sealable chamber 30 (FIG. 2) therein for receiving wastewater, for example, from a building. In one aspect, the upper portion has a generally constant cross-section and the lower portion has a tapered cross-section to reduce retained sewage. The upper portion and/or the lower portion may include a plurality of vertical ribs 25 and horizontal ribs 27 defining a plurality of recessed pockets 29. The plurality of vertical ribs, the plurality of horizontal ribs, and the plurality of recessed pockets are configured to provide an opening for installation of at least one of an inlet, an outlet, and a vent. The ribs and pockets may provide an inlet, an outlet, or a vent at continuous selectable vertical elevations along the upper portion of the container. As best shown in FIG. 2, the bottom of the sewage tank may include a concave bottom 23.

[0026] Another aspect of the present invention is the elimination of conventional concrete ballast thereby eliminating the need and labor associated with pouring concrete around the bottom of the sewage tank in the ground to prevent it from floating upward due to its buoyancy under high ground water conditions.

[0027] As shown in FIGS. 1 and 2, sewage tank 20 may include a two-piece ring or flange 40 that may be connectable to the bottom of the tank. Flange 40 increases the footprint of the sewage tank (e.g., extends laterally outward from the sidewall) so that the soil above the flange acts as a ballast preventing the sewage tank from floating upwardly and popping out of the ground during high ground water conditions. The flanges may include bolt-

CONFIRMATION COPY

on flanges, snap-on flanges, or other suitably connectable flanges. The flange may be provided with an inwardly-extending tongue 42 that is received in a groove 26 extending around the bottom of the sewage tank.

In addition, the sewage tank without the flange may allow conventional installation with concrete. For example, the concrete can grab on or secure to the groove on the bottom of the sewage tank.

[0028] The size of the flange may be determined based on the displaced volume of the soil and/or the volume of the sewage tank in order to provide suitable ballast under high ground water conditions. In one embodiment, a sewage tank about 95 inches (2.4 meters) high (with access way extension) and about 29 inches (0.7 meters) wide may include a flange having an outer circular edge with a diameter of about 40 inches (1.0 meters).

[0029] The bottom portion of the sewage tank may be tapered so that when the pump shuts off the sewage remaining in the bottom of the sewage tank is reduced compared to a tank having a constant cross-section from top to bottom. Desirably, the taper is not too great thereby making it difficult to backfill and compact the backfill during installation.

[0030] FIGS. 3 and 4 illustrate another embodiment of a sewage tank 100 in accordance with the present invention (generally similar to sewage tank 20) which includes an integrally formed stepped ballast ring 110 that extends around the bottom of the sewage tank and which is sized to eliminate the need for installing a concrete ballast. In addition, the stepped configuration allows a plurality of sewage tanks to be nested together for shipment as best shown in FIG. 5. For example, on one side of the sewage tank, a portion of the flange is disposed at a different vertical height than an opposite portion of the flange. The lower and higher portions of the flange allow a plurality of

sewage tanks to be compactly arranged as shown in FIG. 5 to optimize shipping.

[0031] Another feature is that the top may incorporate two flats 112 on the side of the tank so that a forklift truck can readily grab the tank and so that the need to bolt the tank to a traditional pallet is eliminated. The forklift truck may engage the top of the tank by either of two directions and reduce the effort required in loading and unloading the tank.

[0032] In addition, upwardly-extending protrusions or stops 120 (FIG. 3) may be molded into the inner bottom surface for receiving and retaining the stand for supporting the grinder pump in the center of the tank. For example, four protrusions may be provided.

[0033] FIGS. 6-8 illustrate another embodiment for a sewage tank 200 in accordance with the present invention (generally similar to sewage tank 20) that includes the sewage tank having a relatively large diameter flange formed integral with the tank. The flange is desirably sized large enough to provide suitable ballast to keep the sewage tank from floating without the need for concrete. It is also noted that concrete may be employed for increasing the retention of the sewage tank in the ground.

[0034] The various tanks may incorporate a series of four vertical ribs. The vertical areas are designed so that an opening may be cut along the vertical area for receiving a feed wastewater pipe. A grommet may be placed in the opening for receiving and sealing around the inlet pipe. Similarly, an opening may be cut along a vertical area through which a discharge pipe may pass. In addition, an opening may be cut along the vertical area through which a vent may pass. The feed wastewater pipe,

discharge pipe, and vent may also pass through the horizontal ribs or pockets between the ribs.

[0035] The top may also be set up to receive an access way extension (e.g., as shown in FIG. 8) so that the height of the sewage tank could be increased in various increments. In addition, the sewage tank may include a releasably sealable cap having a vent opening (e.g., FIG. 7).

[0036] During fabrication of the tank, a top may be integrally formed with the side wall and bottom. The top can then be cut out, e.g., trimmed to provide an opening to the tank, during installation. Desirably, the top or cover may be either isolated or contain a vent tab allowing either internally venting through a cover system or laterally through the sidewall. FIG. 9 illustrates a top having inwardly extending portion 50 forming a kidney-shaped cutout in the top. The inwardly extending portion may include a vent opening 52.

[0037] FIGS. 10-12 illustrate another embodiment for a sewage tank 300 in accordance with the present invention which is generally similar to sewage tank 20. A plurality of pads 310, 320, and 330 are provided for use in providing an opening for providing an inlet for a feed wastewater pipe or discharge pipe. The pads, ribs, and pockets allow providing an opening for installation of at least one of a feed wastewater pipe and a discharge pipe at continuous selectable elevations along the upper portion of the sewage tank.

[0038] The grinder pump for use in the various systems may include a grinder mechanism for pulverizing solids or semisolid matter in the wastewater, a pump assembly attached to the grinder mechanism for pumping ground wastewater through the grinder pump, and a motor. For example, a grinder mechanism may include a stationary outer ring and a

rotating cutting blade, and a pump assembly may include a progressing cavity pump having a pump housing, a pump stator, and a pump rotor. It will be appreciated by those skill in the art that other suitable grinder pumps, grinding mechanisms and pump assemblies may be employed.

[0039] A motor housing casting houses the electric motor for powering both the grinder mechanism and the pump assembly. As noted above, the housing is preferably attached to a support that sits on the bottom of the sewage tank.

[0040] As noted above, the grinder pump is connected to wastewater discharge pipe. In operation, wastewater is drawn into grinder mechanism for cutting or grinding of the solids or semisolid matter in the wastewater. The resulting processed particulate effluent passes through pump assembly and then through the wastewater discharge pipe. The processed wastewater may travel to a remote location, e.g., to a pressure sewage main and ultimately to a sewage treatment plant.

[0041] The grinder pump may include one or more sensing tubes to sense pressure variations for measuring the level of wastewater collected in tank. A processor and/or a mechanical-electrical relay are desirably operable, upon the wastewater reaching a predetermined wastewater level, to energize the motor within the motor housing casting.

[0042] The various sewage tanks may be rotational molded and formed from high density polyethylene. A mold may be set up so that a sewage tank may be formed for use with a detachable flange or with a relatively small integral flange for use with concrete or a relatively larger flange so that concrete is not required.

[0043] For the embodiments of the sewage tank where the flange is not needed or where concrete is required, installation may include digging a hole, placing the sewage tank in the ground, and then pouring concrete down in the bottom of the hole.

[0044] While various embodiments of the present invention have been illustrated and described, it will be appreciated by those skilled in the art that many further changes and modifications may be made thereunto without departing from the spirit and scope of the invention.

What is claimed is:

1. A sewage tank for use with a pump to convey sewage, said sewage tank comprising:
 - a container comprising a sidewall having an upper portion and a lower tapering portion defining a chamber, said lower tapering portion having a reduced size compared to said upper portion; and
 - said upper portion comprising a plurality of intersecting ribs defining a plurality of recessed pockets, and said lower tapering portion comprising a plurality of intersecting ribs defining a plurality of recessed pockets, some of said recessed pockets of said lower tapering portion defined by an outer surface of said sidewall of said lower tapering portion and being entirely surrounded by said intersecting ribs extending outwardly from said sidewall of said lower tapering portion so that said outer portions of said surrounding intersecting ribs define a plurality of openings to said recessed pockets which said plurality of openings is spaced from said outer surface of said sidewall of said lower tapering portion.
2. The sewage tank of claim 1 wherein at least some of said plurality of ribs, and said plurality of recessed pockets are configured to provide an opening for installation of at least one of an inlet, an outlet, and a vent.
3. The sewage tank of claim 2 wherein said opening for installation of said at least one of an inlet, an outlet, and a vent is positionable at a continuous selectable vertical elevation along said upper portion of said container.
4. The sewage tank of claim 1 wherein said lower portion of said container comprises a concave bottom.
5. The sewage tank of claim 1 wherein said lower portion of said container comprises an outwardly extending member spaced below the upper portion

and generally adjacent to a bottom of said lower tapering portion and wherein said taper of said lower portion and said outwardly extending member are configured to allow backfilling of said sewage tank so that the backfill provides sufficient ballast under high ground water conditions.

6. The sewage tank of claim 5 wherein said outwardly extending member comprises an outwardly extending flange.

7. The sewage tank of claim 6 wherein said flange is releasably attachable to said lower portion of said container.

8. The sewage tank of claim 6 wherein a first portion of said outwardly flange is disposed at a first vertical elevation, and a second portion of said flange is disposed at a second vertical elevation different from said first vertical elevation.

9. The sewage tank of claim 1 wherein said upper portion comprises a generally horizontal inwardly extending portion for providing an opening for a vent.

10. The sewage tank of claim 9 wherein said upper portion is integrally formed with said generally horizontal inwardly extending portion to provide said opening for the vent.

11. The sewage tank of claim 1 further comprising a pump disposable in said sewage tank.

12. The sewage tank of claim 11 wherein said pump comprises a grinder pump.

13. A sewage tank for use with a pump to convey sewage, said sewage tank comprising:

a container having an upper portion and a lower tapering portion defining a chamber, and having a longitudinal axis;

said lower tapering portion comprising a lowermost portion defining a bottom of said container, and lower tapering portion having a reduced size compared to said upper portion;

an outwardly extending member comprising a plurality of separate outwardly-extending member portions releasably attachable around said lower tapering portion of said container and disposable generally normal to said longitudinal axis, said plurality of separate outwardly-extending member portions being attachable below a bottom of the upper portion, spaced below a portion of the lower tapering portion, and being attachable generally adjacent said bottom of said container so that an elevational distance from said plurality of separate outwardly-extending member portions to said bottom of said upper portion is greater than an elevational distance from said plurality of separate outwardly-extending member portions to said bottom of said container.

14. The sewage tank of claim 13 wherein said outwardly extending member comprises an outwardly extending flange.

15. The sewage tank of claim 13 wherein said upper portion comprises a generally horizontal inwardly extending portion for providing an opening for a vent.

16. The sewage tank of claim 15 wherein said upper portion is integrally formed with said generally horizontal inwardly extending portion to provide said opening for the vent.

17. The sewage tank of claim 13 further comprising a pump disposable in said sewage tank.

18. The sewage tank of claim 17 wherein said pump comprises a grinder pump.

19. A sewage tank for use with a pump to convey sewage, said sewage tank comprising:

a container for containing the pump; and

said container comprising an upper portion defining a horizontally disposed access opening accessible therethrough by a workman to said container defining an integrally formed generally horizontal inwardly extending portion extending into said access opening adjacent to a side of said container so that said access opening comprises a kidney-shaped access opening, said horizontal inwardly-extending portion having a horizontally-extending opening disposed adjacent to said side of said container for a vent.

20. The sewage tank of claim 19 further comprising a pump disposable in said sewage tank.

21. The sewage tank of claim 20 wherein said pump comprises a grinder pump.

22. A sewage tank for use with a pump to convey sewage, said sewage tank comprising:

a container having an upper portion and a lower portion defining a chamber, said upper portion having a generally constant cross-section and said lower portion having a tapered cross section to reduce retained sewage;

at least one of said upper portion and said lower portion comprising a plurality of vertical ribs and horizontal ribs defining a plurality of recessed pockets; and

wherein said lower portion of said container comprises an outwardly extending member and wherein said taper of said lower portion and said outwardly extending member are configured to allow backfilling of said

sewage tank so that the backfill provides sufficient ballast under high ground water conditions, said outwardly extending member comprises an outwardly extending flange, and a first portion of said outwardly flange is disposed at a first vertical elevation, and a second portion of said flange is disposed at a second vertical elevation different from said first vertical elevation so that when upright first and second sewage tanks are nested together with upper and lower portions disposed side-by-side for shipment, said first portion of said outwardly-extending member of said first sewage tank is positionable over said second portion of said outwardly-extending member of said second sewage tank.

23. A sewage tank for use with a pump to convey sewage, said sewage tank comprising:

a container having an upper portion and a lower tapering portion defining a chamber;

said upper portion having a generally constant cross-section and said lower portion having a tapered cross-section to reduce retained sewage;

said lower portion of said container comprising an outwardly extending member;

said taper of said lower portion of said container and said outwardly extending member are configured to allow backfilling of said sewage tank so that the backfill provides sufficient ballast under high ground water conditions; and

wherein said outwardly extending member comprises an outwardly extending flange, and a first portion of said outwardly extending flange is disposed at a first vertical elevation, and a second portion of said flange is disposed at a second vertical elevation different from said first vertical elevation so that when upright first and second sewage tanks are nested together with upper and lower portions disposed side-by-side for shipment, said first portion of said outwardly-extending member of said first sewage tank

is positionable over said second portion of said outwardly-extending member of said second sewage tank.

24. A sewage tank for use with a pump to convey sewage, said sewage tank comprising:

a container for containing the pump;

a lower portion of said container comprises an outwardly-extending member configured to allow backfilling of said sewage tank so that the backfill provides sufficient ballast under high ground water conditions; and

wherein said outwardly-extending member comprises a first portion having a first upper surface disposed at a first vertical elevation, and a second portion having a second upper surface disposed at a second vertical elevation different from said first vertical elevation so that when upright first and second sewage tanks are nested together with upper and lower portions disposed side-by-side for shipment, said first portion of said outwardly-extending member of said first sewage tank is positionable over said second portion of said outwardly-extending member of said second sewage tank.

25. The sewage tank of claim 24 wherein said outwardly-extending member comprises a third portion and a fourth portion disposed on an angle and between said first portion and said second portion.

26. The sewage tank of claim 24 wherein said outwardly-extending member comprises an outwardly-extending flange.

27. The sewage tank of claim 24 wherein said outwardly-extending member and said lower portion of said container is monolithic.

28. The sewage tank of claim 24 wherein said lower portion comprises a lower tapering portion having a reduced size compared to an upper portion of said container.

29. The sewage tank of claim 5 wherein at least some of said plurality of ribs, and said plurality of recessed pockets are configured to provide an opening for installation of at least one of an inlet, an outlet, and a vent.

30. The sewage tank of claim 29 wherein said opening for installation of said at least one of an inlet, an outlet, and a vent is positionable at a continuous selectable vertical elevation along said upper portion of said container.

31. The sewage tank of claim 5 wherein said lower portion of said container comprises a concave bottom.

32. The sewage tank of claim 5 wherein said upper portion comprises a generally horizontal inwardly extending portion for providing an opening for a vent.

33. The sewage tank of claim 32 wherein said upper portion is integrally formed with said generally horizontal inwardly extending portion to provide said opening for the vent.

34. The sewage tank of claim 5 further comprising a pump disposable in said sewage tank.

35. The sewage tank of claim 34 wherein said pump comprises a grinder pump.

36. The sewage tank of claim 1 wherein said plurality of intersecting ribs of said upper portion comprises a plurality of intersecting vertical and horizontal ribs defining the plurality of recessed pockets, and said plurality of intersecting ribs of said lower tapering portion comprises a plurality of intersecting vertical and horizontal ribs defining the plurality of recessed pockets.

37. The sewage tank of claim 5 wherein said plurality of intersecting ribs of said upper portion comprises a plurality of intersecting vertical and horizontal ribs defining the plurality of recessed pockets, and said plurality of intersecting ribs of said lower tapering portion comprises a plurality of intersecting vertical and horizontal ribs defining the plurality of recessed pockets.
38. The sewage tank of claim 13 wherein said container comprises a plurality of intersecting ribs.
39. The sewage tank of claim 13 wherein said outwardly-extending member and said lower portion of said container is monolithic.
40. The sewage tank of claim 19 wherein said container comprises a plurality of intersecting ribs.
41. The sewage tank of claim 23 wherein said container comprises a plurality of intersecting ribs.
42. The sewage tank of claim 24 wherein said container comprises a plurality of intersecting ribs.
43. The sewage tank of claim 24 wherein said first upper surface of said outwardly-extending member is operably connected to said second upper surface of said outwardly-extending member.
44. A method of installing a sewage tank, the method comprising:
 - providing a sewage tank of claim 1; and
 - backfilling around the lower tapering portion of the sewage tank.

45. A method of installing a sewage tank, the method comprising:
 - providing a sewage tank of claim 5 having a lower tapering portion and an outwardly-extending member; and
 - backfilling around the lower tapering portion of the sewage tank.
46. A method of installing a sewage tank, the method comprising:
 - providing a sewage tank of claim 13 having a lower tapering portion and an outwardly-extending member; and
 - backfilling around the lower tapering portion of the sewage tank.
47. A method of installing a sewage tank, the method comprising:
 - providing a sewage tank of claim 22 having a lower tapering portion and an outwardly-extending member; and
 - backfilling around the lower tapering portion of the sewage tank.
48. A method of installing a sewage tank, the method comprising:
 - providing a sewage tank of claim 23 having a lower tapering portion and an outwardly-extending member; and
 - backfilling around the lower tapering portion of the sewage tank.
49. A method of installing a sewage tank, the method comprising:
 - providing a sewage tank of claim 24 having a lower tapering portion and an outwardly-extending member; and
 - backfilling around the lower tapering portion.
50. The sewage tank of claim 13 wherein said plurality of separate outwardly-extending member portions comprise a plurality of generally arcuate-shaped members.
51. The sewage tank of claim 50 wherein said plurality of generally arcuate-shaped members comprises a pair of generally arcuate-shaped members.

52. The sewage tank of claim 50 wherein said plurality of generally arcuate-shaped members and said outer surface of said container comprise interlocking portions.

53. The sewage tank of claim 50 wherein said plurality of generally arcuate-shaped members and said outer surface of said container comprise interlocking tongue and groove.

54. A sewage tank for use with a pump to convey sewage, said sewage tank comprising:

a container having an inner surface and an outer surface, said container defining a longitudinal axis; and

a generally ring-shaped member attachable around a generally surrounding portion of said outer surface of said container and disposed generally normal to said longitudinal axis.

55. The sewage tank of claim 54 wherein said generally ring-shaped member comprises a plurality of generally arcuate-shaped members attachable around a generally outer circumferential outer surface portion of said container.

56. The sewage tank of claim 54 wherein said generally ring-shaped member comprises a pair of generally arcuate-shaped members attachable around a generally outer circumferential outer surface portion of said container.

57. The sewage tank of claim 54 wherein said generally ring-shaped member and said outer surface of said container comprise interlocking portions.

58. The sewage tank of claim 57 wherein said generally ring-shaped member and said outer surface of said container comprise interlocking tongue and groove.

59. The sewage tank of claim 54 wherein said generally ring-shaped member is configured for backfilling of material on top of said ring-shaped member for providing additional ballast under high ground water conditions.

60. The sewage tank of claim 54 wherein said generally ring-shaped member comprises an outwardly extending flange.

61. The sewage tank of claim 54 wherein said generally ring-shaped member is releasably attachable to a generally outer lower circumferential outer surface portion of said container.

62. The sewage tank of claim 61 wherein said generally ring-shaped member comprises a plurality of generally arcuate-shaped members attachable around said generally outer lower circumferential outer surface portion of said container.

63. The sewage tank of claim 61 wherein said generally ring-shaped member comprises a pair of generally arcuate-shaped members attachable around said generally outer lower circumferential outer surface portion of said container.

64. The sewage tank of claim 62 wherein said generally ring-shaped member and said outer surface of said container comprise interlocking portions.

65. The sewage tank of claim 64 wherein said generally ring-shaped member and said outer surface of said container comprise interlocking tongue and groove.

66. The sewage tank of claim 64 wherein said generally ring-shaped member is configured for backfilling of material on top said ring-shaped member for providing additional ballast under high ground water conditions.

67. The sewage tank of claim 64 wherein said generally ring-shaped member comprises an outwardly extending flange.

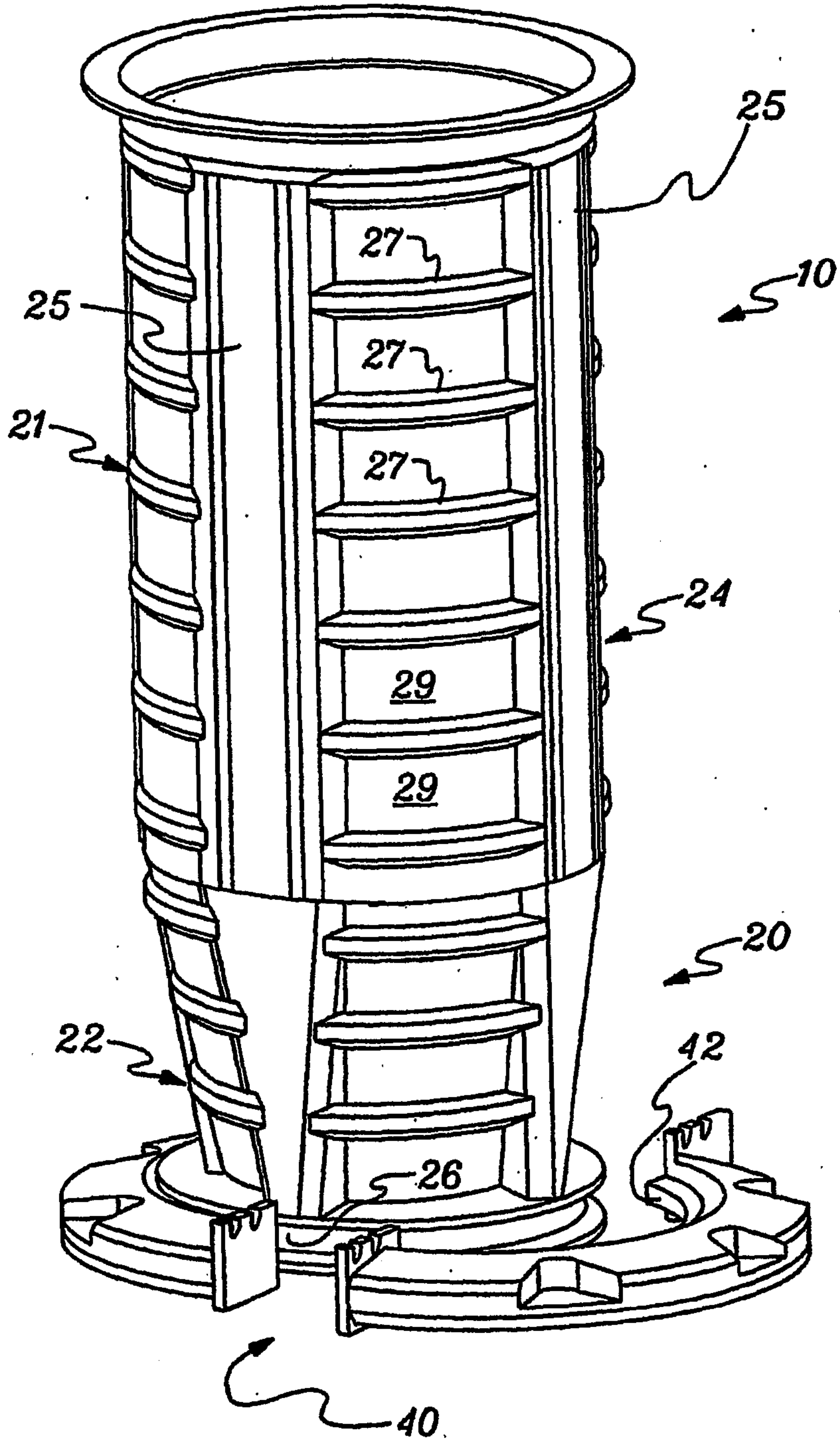

fig. 1

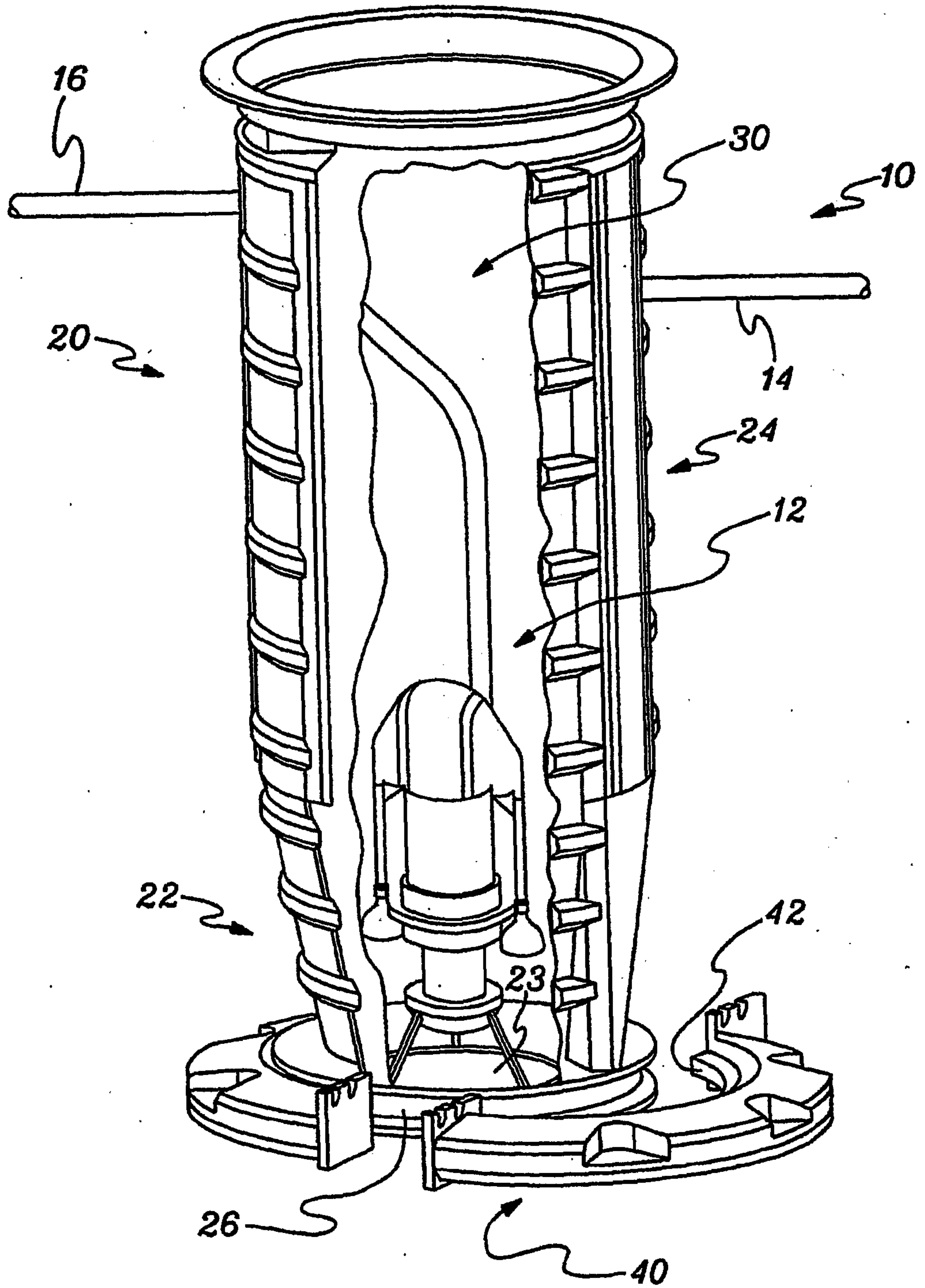

fig. 2

CONFIRMATION COPY

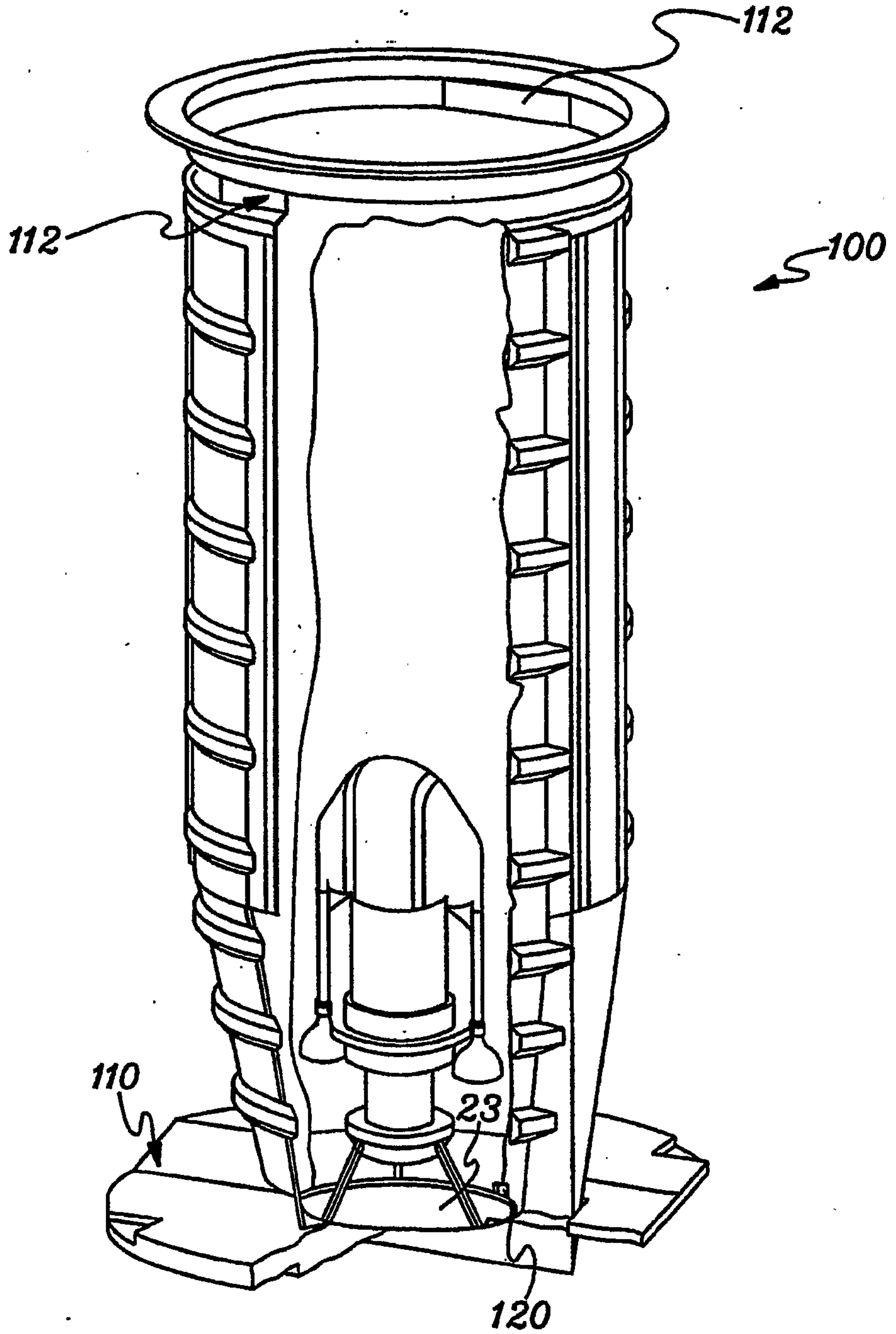

fig. 3

Printed: 16/06/2006

DRAWPAMD
0830.081W0

CONFIRMATION COPY

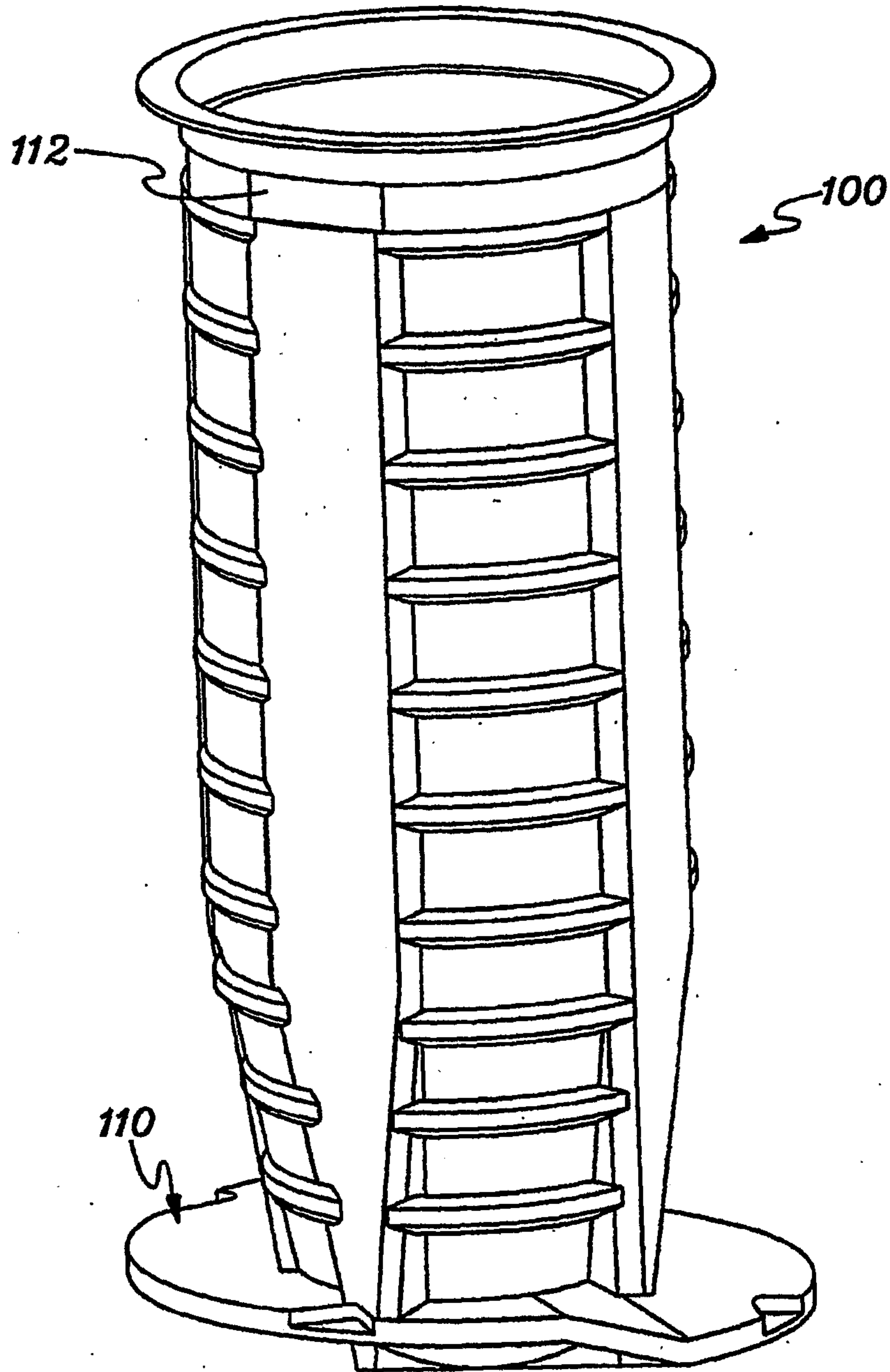

fig. 4

CONFIRMATION COPY

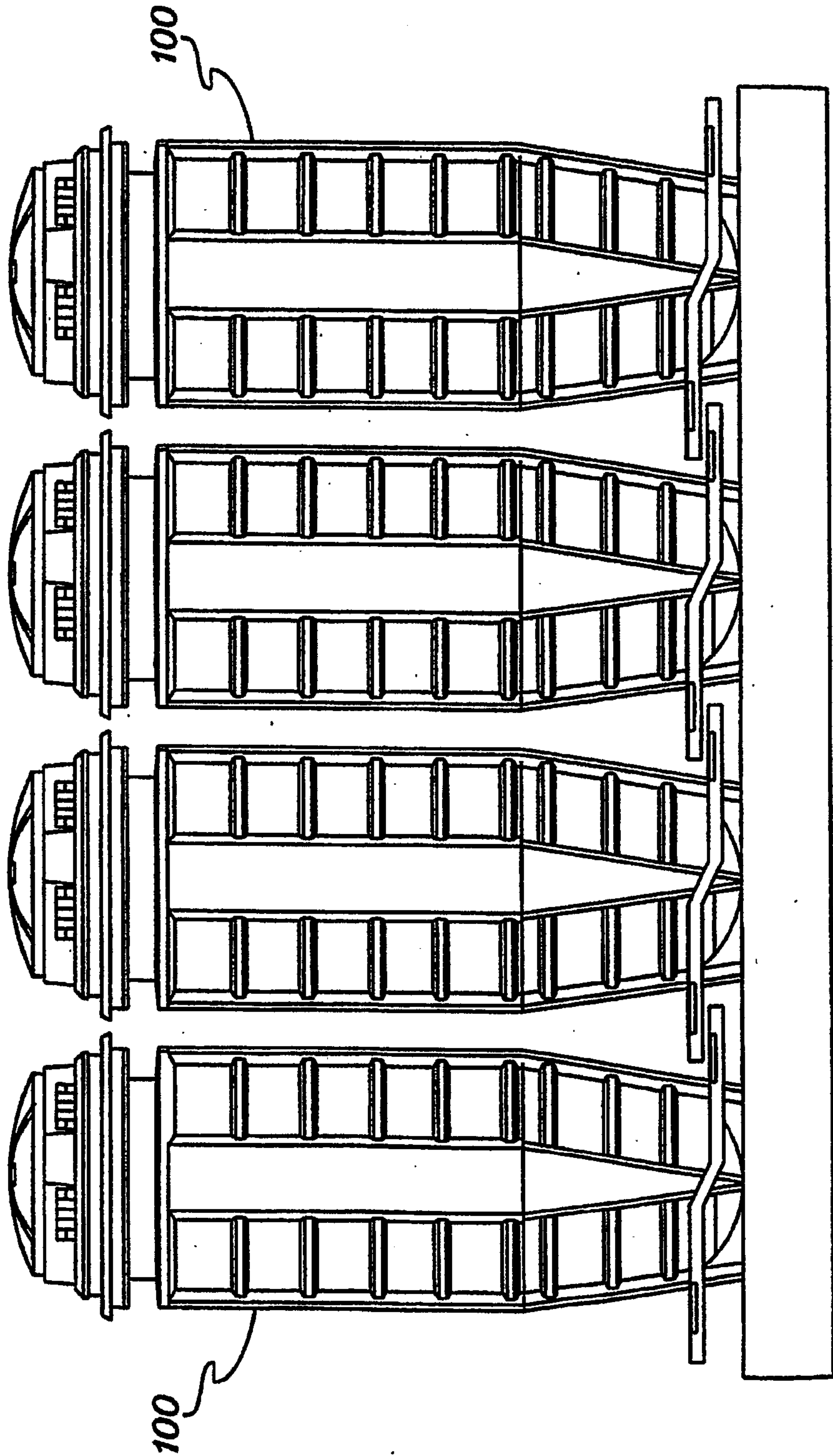

fig. 5

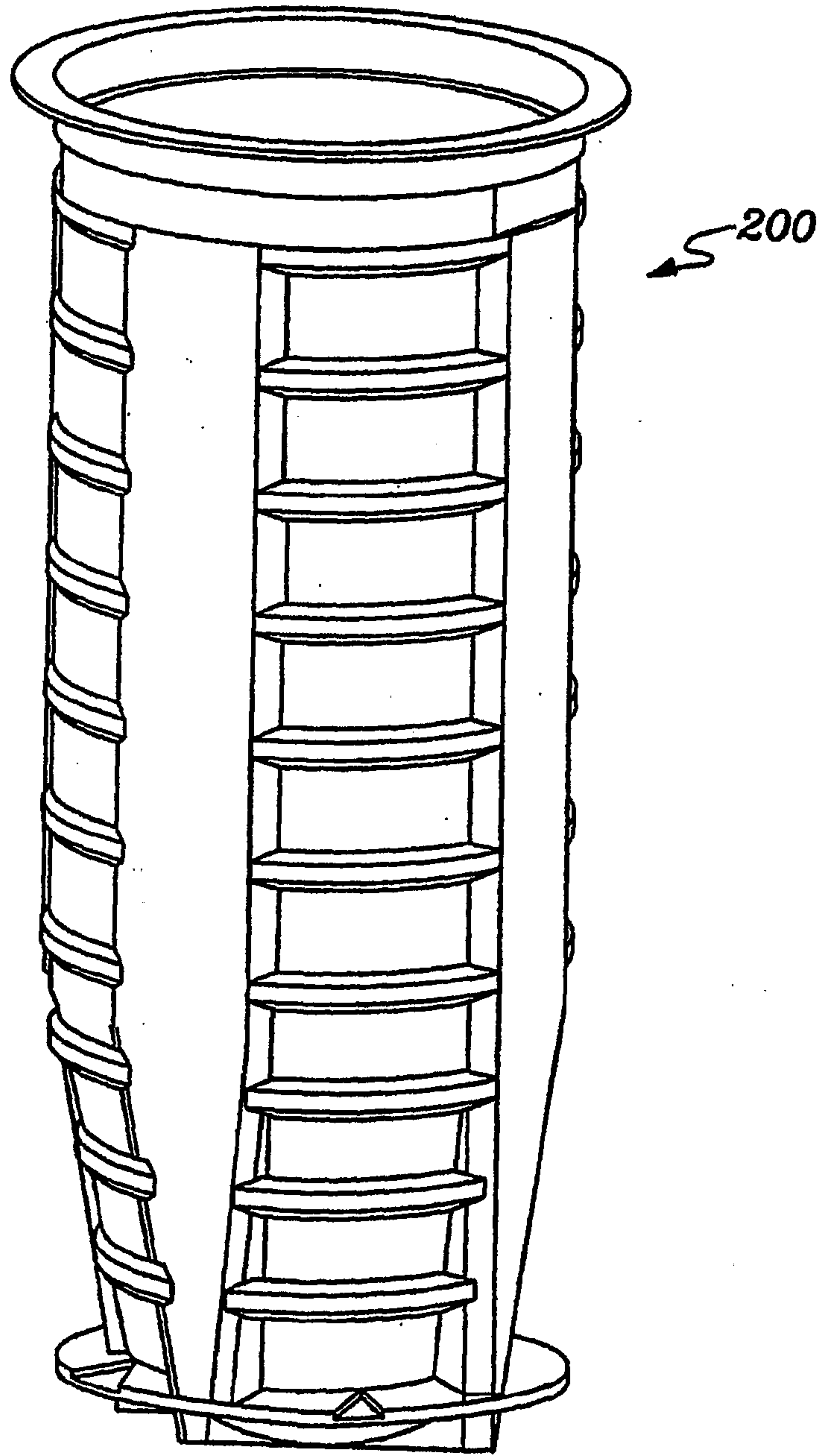

fig. 6

Printed: 16/06/2006

DRAWPAMD

0830.081W0

CONFIRMATION COPY

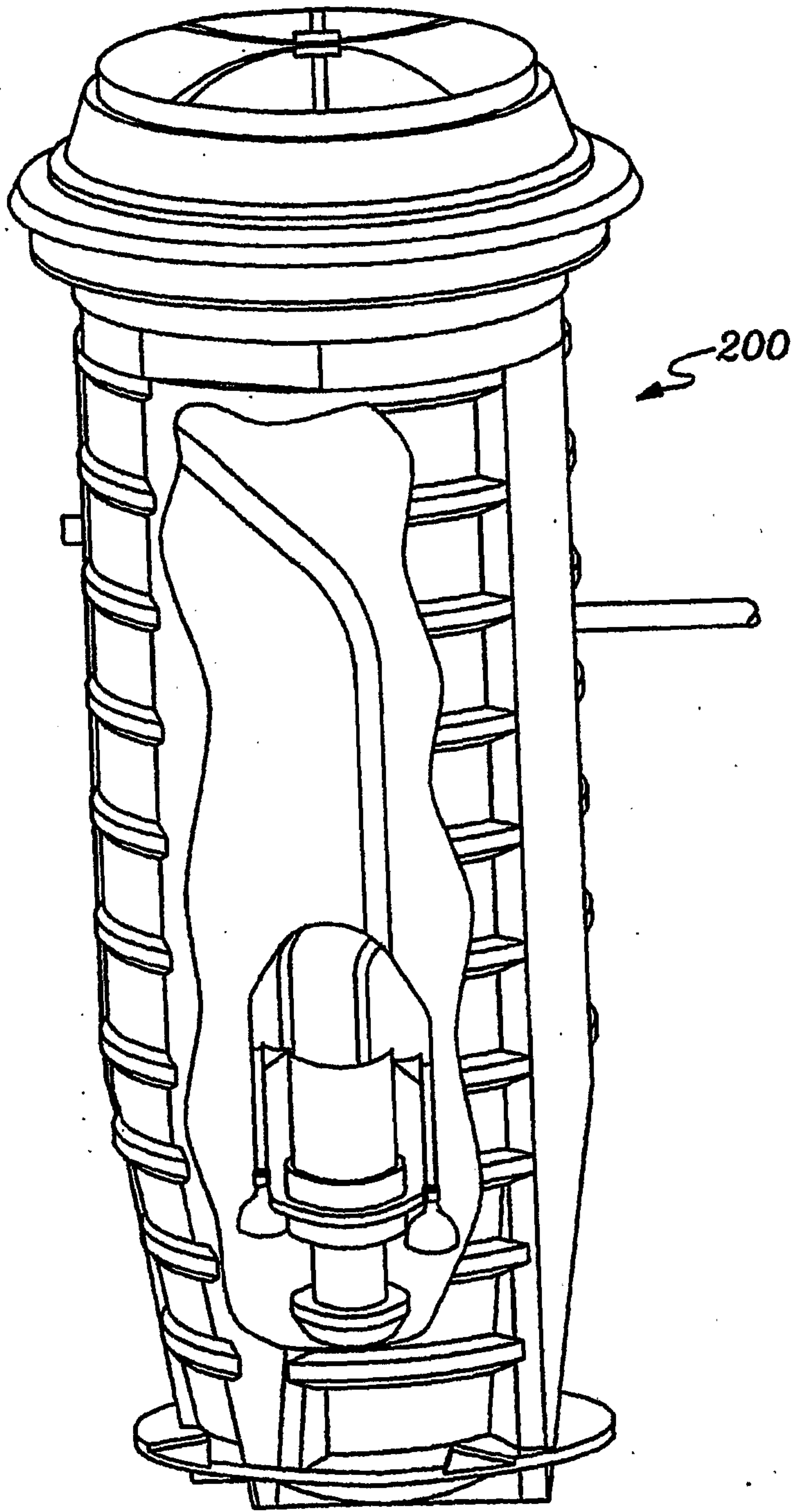

fig. 7

Printed: 16/06/2006

DRAWPAMD

0830.081W0

CONFIRMATION COPY

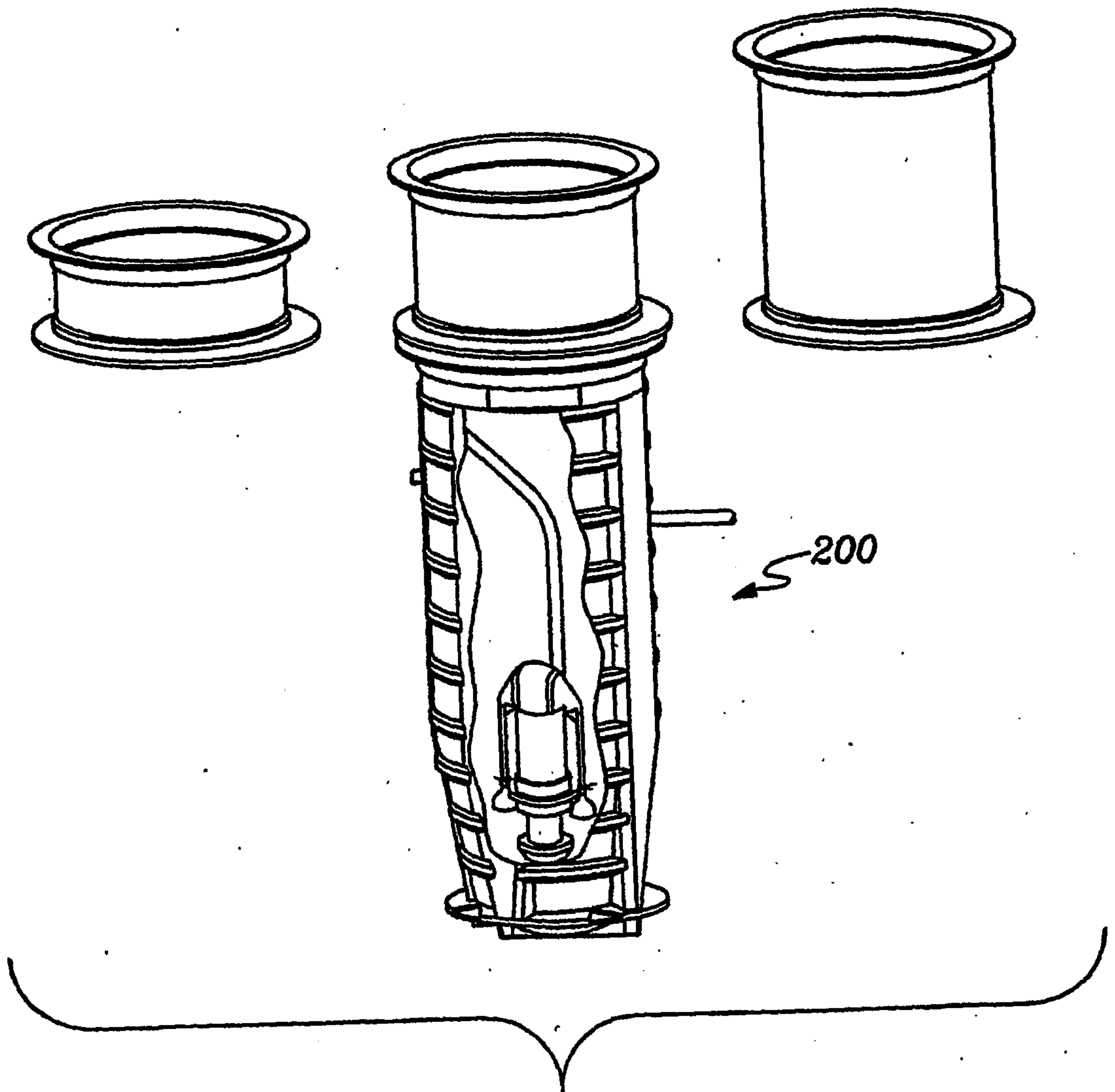

fig. 8

Printed: 16/06/2006

DRAWPAMD

US0527280

CONFIRMATION COPY

0830.081WO

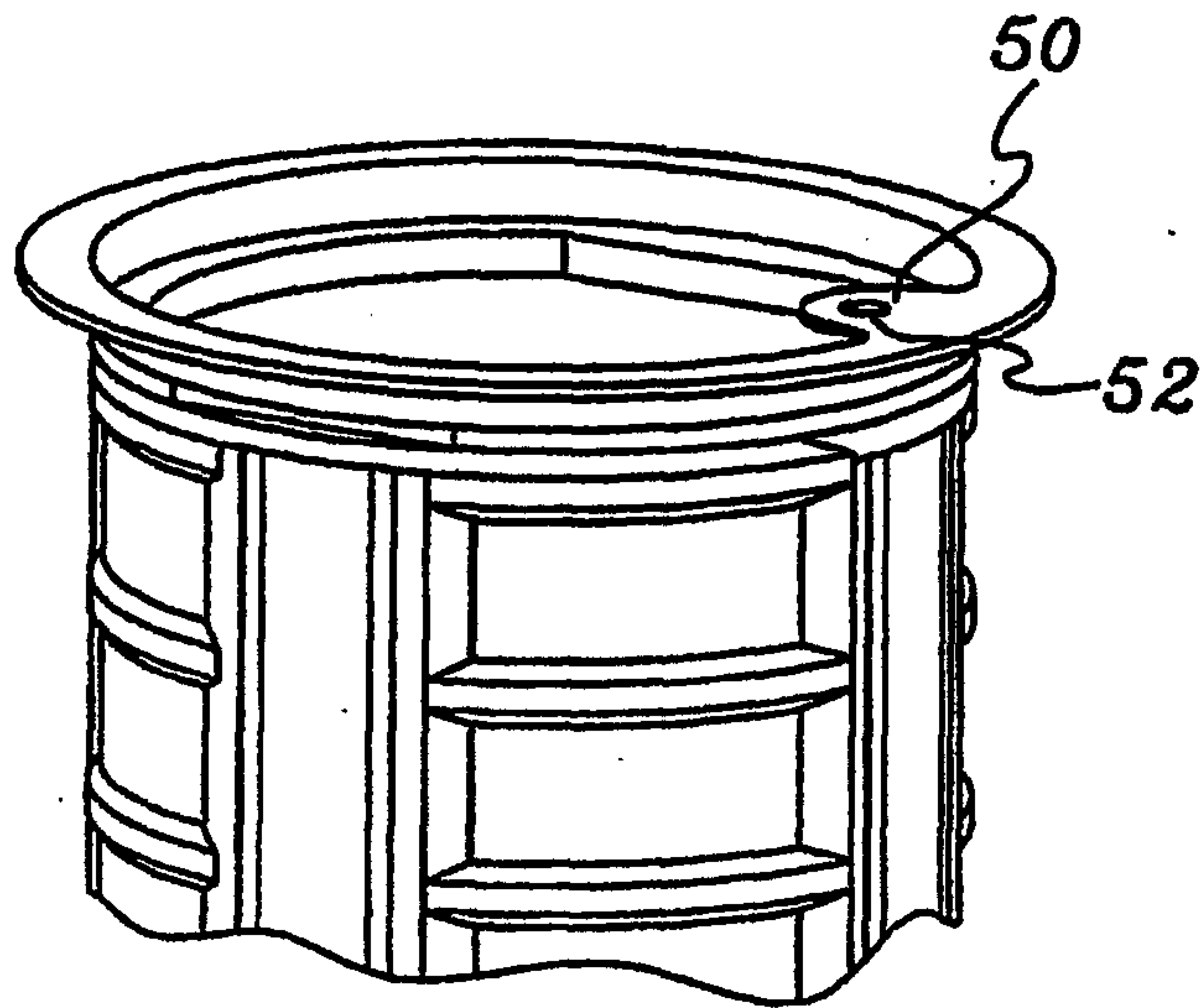

fig. 9

Printed: 16/06/2006

DRAWPAMD

10/12

0830.081W0

CONFIRMATION COPY

300

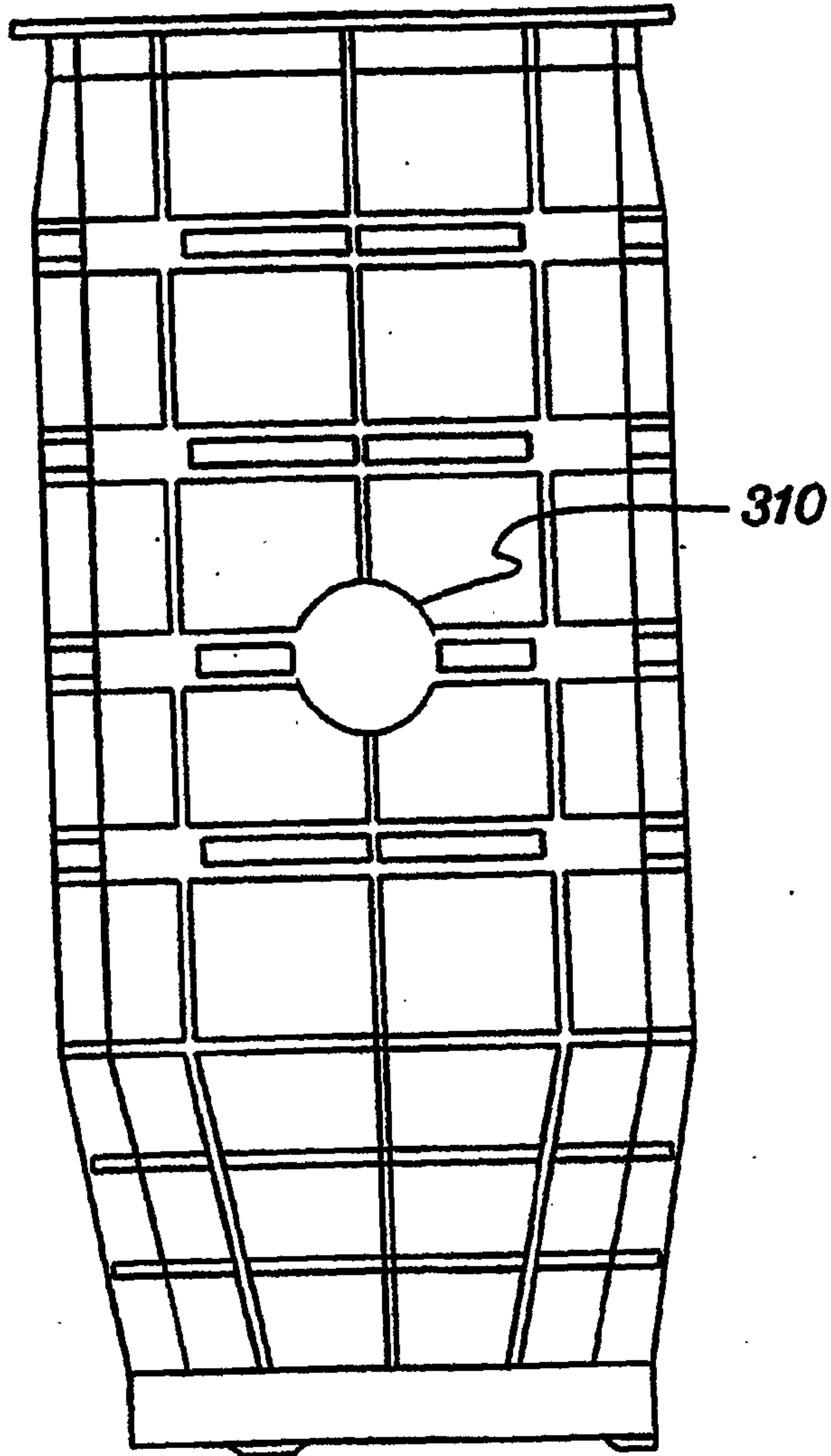

fig. 10

Printed: 16/06/2006

DRAWPAMD

11/12

0830.081WO

US0527280

CONFIRMATION COPY

300

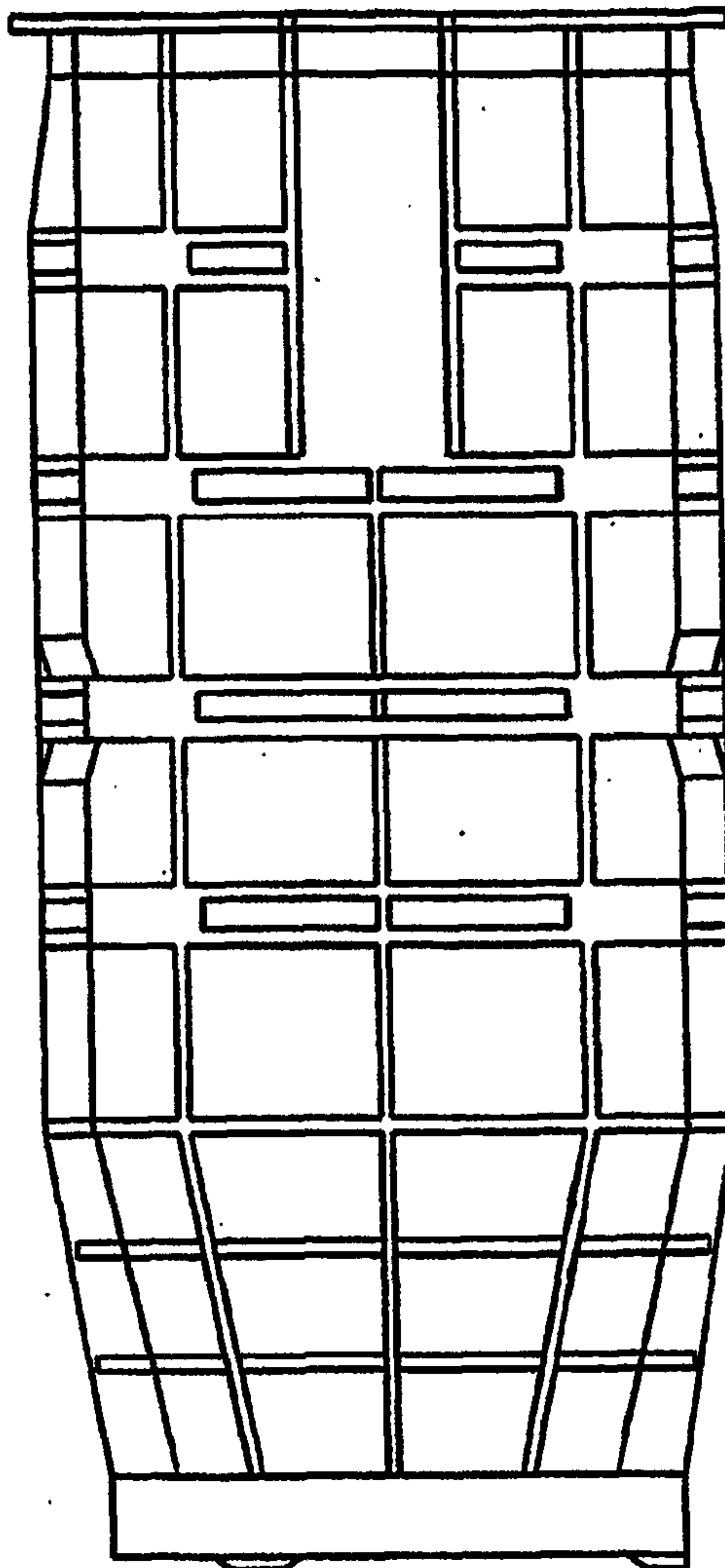

fig. 11

CONFIRMATION COPY

300

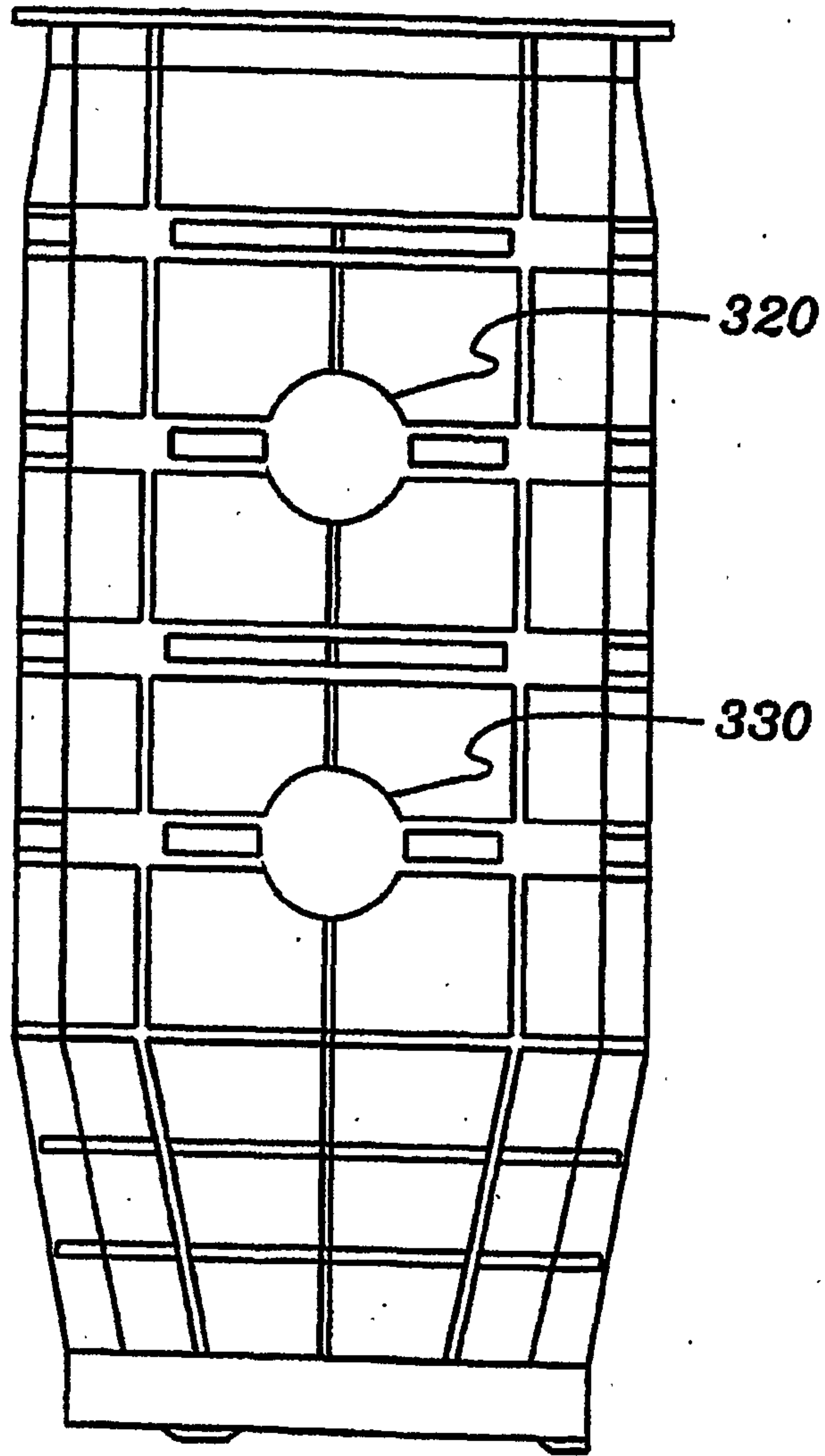

fig. 12

