

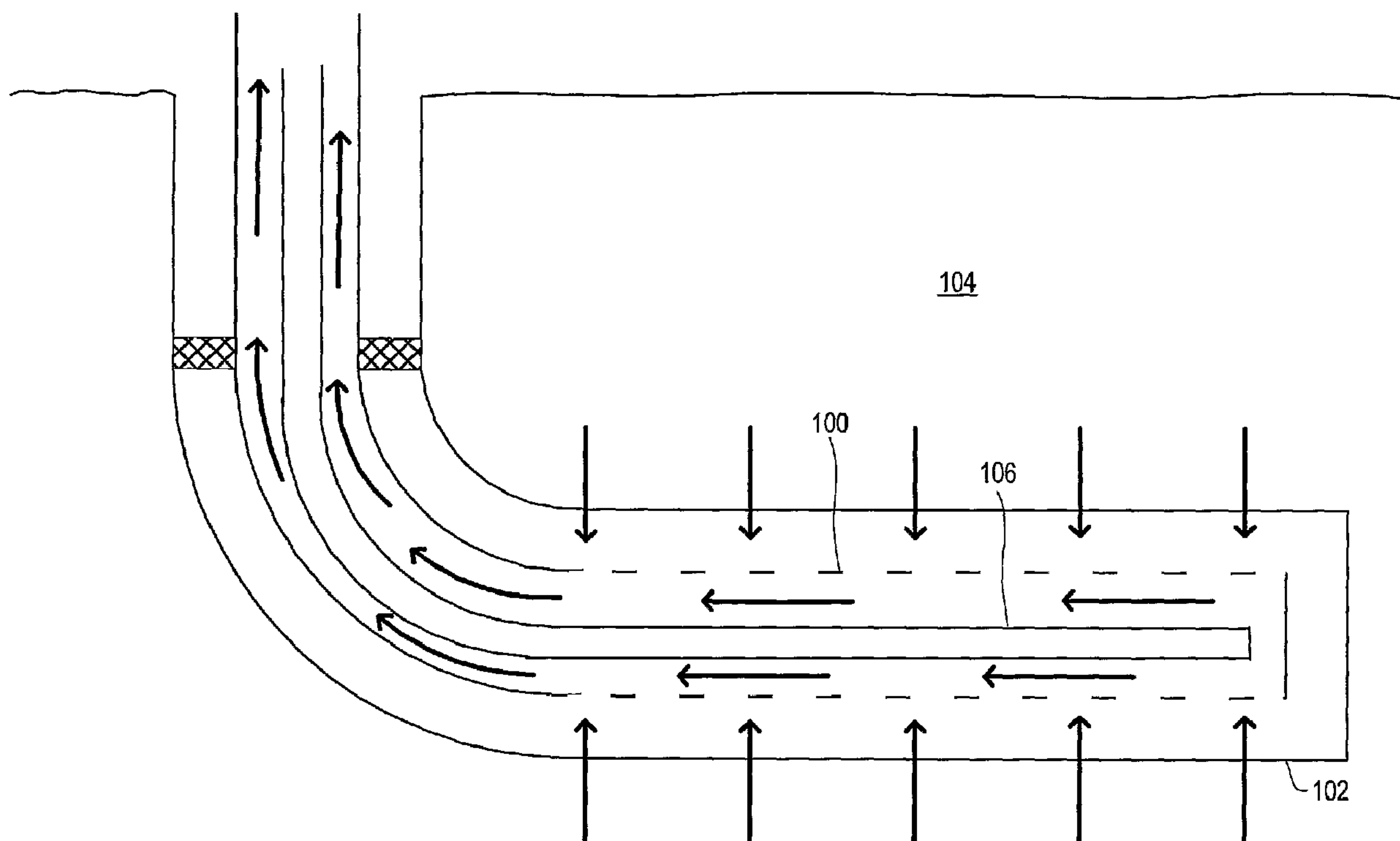

(86) Date de dépôt PCT/PCT Filing Date: 2005/04/22
 (87) Date publication PCT/PCT Publication Date: 2005/11/10
 (45) Date de délivrance/Issue Date: 2013/06/18
 (85) Entrée phase nationale/National Entry: 2006/10/18
 (86) N° demande PCT/PCT Application No.: US 2005/013891
 (87) N° publication PCT/PCT Publication No.: 2005/106194
 (30) Priorité/Priority: 2004/04/23 (US60/565,077)

(51) Cl.Int./Int.Cl. *E21B 43/24* (2006.01),
E21B 43/12 (2006.01)
 (72) Inventeurs/Inventors:
PASTOR-SANZ, GUILLERMO, US;
VINEGAR, HAROLD J., US
 (73) Propriétaire/Owner:
SHELL INTERNATIONALE RESEARCH
MAATSCHAPPIJ B.V., NL
 (74) Agent: NORTON ROSE FULLBRIGHT CANADA
S.E.N.C.R.L., S.R.L.

(54) Titre : REDUCTION DE LA VISCOSITE DE L'HUILE A PRODUIRE A PARTIR D'UNE FORMATION CONTENANT DES HYDROCARBURES
 (54) Title: REDUCING VISCOSITY OF OIL FOR PRODUCTION FROM A HYDROCARBON CONTAINING FORMATION



(57) **Abrégé/Abstract:**

The invention provides a method comprising: applying electrical current to one or more electrical conductors located in an opening in the formation to provide an electrically resistive heat output; allowing the heat to transfer from the electrical conductors to a part of the formation containing hydrocarbons so that a viscosity of fluids in the part at or near the opening in the formation is reduced; providing a gas at one or more locations in the opening to reduce the density of the fluids so that the fluids are lifted in the opening towards the surface of the formation by the formation pressure; and producing the fluids through the opening.



(12) INTERNATIONAL APPLICATION PUBLISHED UNDER THE PATENT COOPERATION TREATY (PCT)

(19) World Intellectual Property
Organization
International Bureau



(43) International Publication Date
10 November 2005 (10.11.2005)

PCT

(10) International Publication Number
WO 2005/106194 A1

- (51) International Patent Classification⁷: **E21B 43/24**, 43/12
- (74) Agents: **CHRISTENSEN, Del S.** et al.; SHELL OIL COMPANY, One Shell Plaza, P.O. Box 2463, Houston, Texas 77252-2463 (US).
- (21) International Application Number: PCT/US2005/013891
- (81) Designated States (unless otherwise indicated, for every kind of national protection available): AE, AG, AL, AM, AT, AU, AZ, BA, BB, BG, BR, BW, BY, BZ, CA, CH, CN, CO, CR, CU, CZ, DE, DK, DM, DZ, EC, EE, EG, ES, FI, GB, GD, GE, GH, GM, HR, HU, ID, IL, IN, IS, JP, KE, KG, KM, KP, KR, KZ, LC, LK, LR, LS, LT, LU, LV, MA, MD, MG, MK, MN, MW, MX, MZ, NA, NI, NO, NZ, OM, PG, PH, PL, PT, RO, RU, SC, SD, SE, SG, SK, SL, SM, SY, TJ, TM, TN, TR, TT, TZ, UA, UG, US, UZ, VC, VN, YU, ZA, ZM, ZW.
- (22) International Filing Date: 22 April 2005 (22.04.2005)
- (84) Designated States (unless otherwise indicated, for every kind of regional protection available): ARIPO (BW, GH, GM, KE, LS, MW, MZ, NA, SD, SL, SZ, TZ, UG, ZM, ZW), Eurasian (AM, AZ, BY, KG, KZ, MD, RU, TJ, TM), European (AT, BE, BG, CH, CY, CZ, DE, DK, EE, ES, FI, FR, GB, GR, HU, IE, IS, IT, LT, LU, MC, NL, PL, PT, RO, SE, SI, SK, TR), OAPI (BF, BJ, CF, CG, CI, CM, GA, GN, GQ, GW, ML, MR, NE, SN, TD, TG).
- (25) Filing Language: English
- (26) Publication Language: English
- (30) Priority Data: 60/565,077 23 April 2004 (23.04.2004) US
- (71) Applicant (for all designated States except US): **SHELL OIL COMPANY** [US/US]; Department of Intellectual Property, One Shell Plaza, P.O. Box 2463, Houston, Texas 77252-2463 (US).
- (72) Inventors; and
- (75) Inventors/Applicants (for US only): **PASTOR-SANZ, Guillermo** [ES/US]; 6118 Saratoga Springs Lane, Houston, Texas 77041 (US). **VINEGAR, Harold J.** [US/US]; 4613 Laurel, Bellaire, Texas 77401 (US).
- Published:
— with international search report

[Continued on next page]

(54) Title: REDUCING VISCOSITY OF OIL FOR PRODUCTION FROM A HYDROCARBON CONTAINING FORMATION

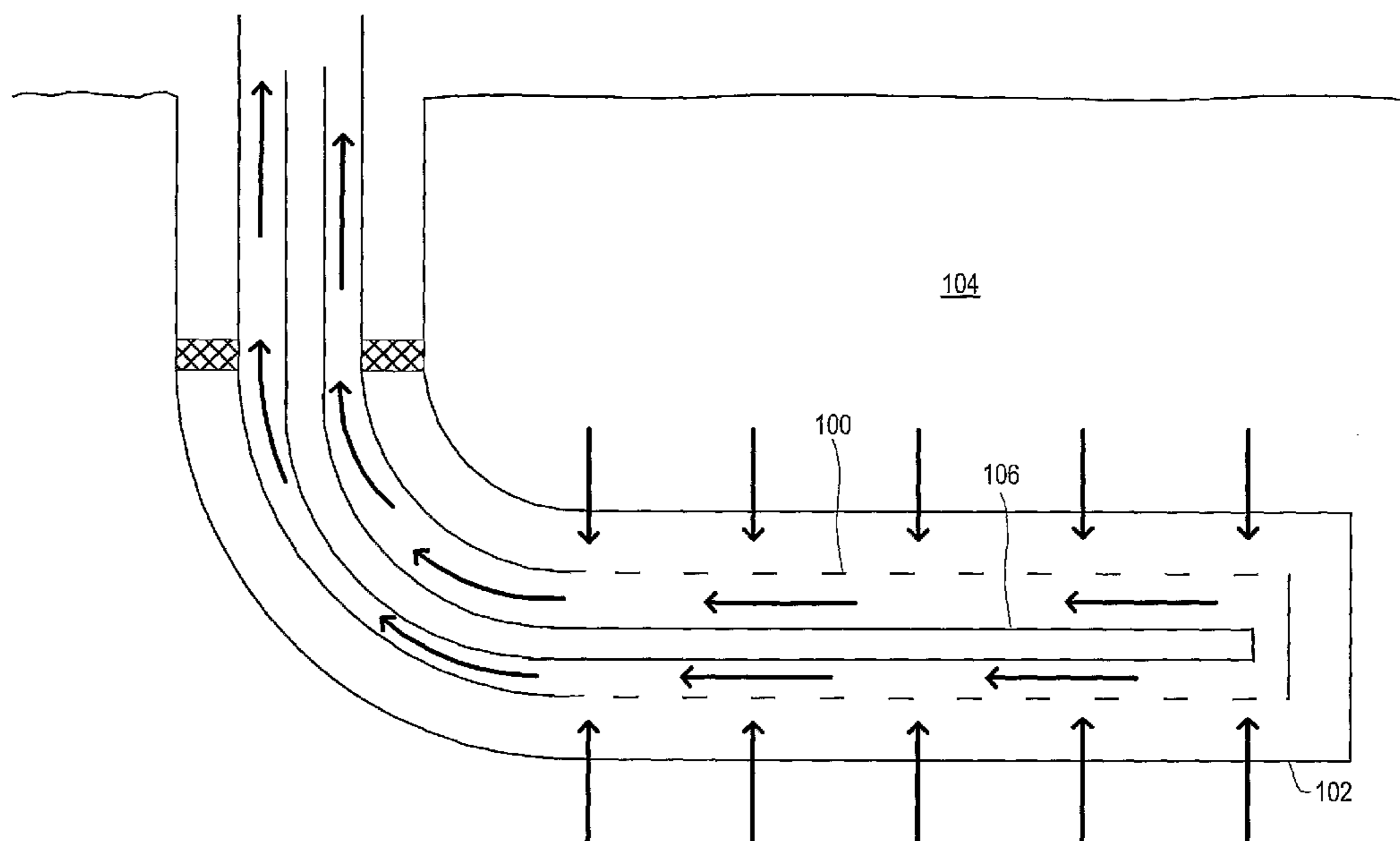

(57) Abstract: The invention provides a method comprising: applying electrical current to one or more electrical conductors located in an opening in the formation to provide an electrically resistive heat output; allowing the heat to transfer from the electrical conductors to a part of the formation containing hydrocarbons so that a viscosity of fluids in the part at or near the opening in the formation is reduced; providing a gas at one or more locations in the opening to reduce the density of the fluids so that the fluids are lifted in the opening towards the surface of the formation by the formation pressure; and producing the fluids through the opening.

WO 2005/106194 A1

WO 2005/106194 A1



For two-letter codes and other abbreviations, refer to the "Guidance Notes on Codes and Abbreviations" appearing at the beginning of each regular issue of the PCT Gazette.

REDUCING VISCOSITY OF OIL FOR PRODUCTION FROM A HYDROCARBON CONTAINING FORMATION

BACKGROUND

Field of the Invention

The present invention relates generally to methods and systems for production of hydrocarbons, hydrogen, and/or other products from various subsurface formations such as hydrocarbon containing formations. Certain embodiments relate to methods and systems for reducing the viscosity of heavy hydrocarbons in subsurface formations and producing the heavy hydrocarbons.

Description of Related Art

Hydrocarbons obtained from subterranean formations are often used as energy resources, as feedstocks, and as consumer products. Concerns over depletion of available hydrocarbon resources and concerns over declining overall quality of produced hydrocarbons have led to development of processes for more efficient recovery, processing, and/or use of available hydrocarbon resources. In situ processes may be used to remove hydrocarbon materials from subterranean formations. Chemical and/or physical properties of hydrocarbon material in a subterranean formation may need to be changed to allow hydrocarbon material to be more easily removed from the subterranean formation. The chemical and physical changes may include in situ reactions that produce removable fluids, composition changes, solubility changes, density changes, phase changes, and/or viscosity changes of the hydrocarbon material in the formation. A fluid may be, but is not limited to, a gas, a liquid, an emulsion, a slurry, and/or a stream of solid particles with flow characteristics similar to liquid flow.

Large deposits of heavy hydrocarbons (for example, heavy oil and/or tar) contained in relatively permeable formations are found in North America, South America, Africa, and Asia. Tar can be surface-mined and upgraded to lighter hydrocarbons such as crude oil, naphtha, kerosene, and/or gas oil. Surface milling processes may further separate bitumen from sand. The separated bitumen may be converted to light hydrocarbons using conventional refinery methods. Mining and upgrading tar sand is usually substantially more expensive than producing lighter hydrocarbons from conventional oil reservoirs.

In situ production of hydrocarbons from tar sands may be accomplished by heating and/or injecting a gas such as steam into the formation. U.S. Patent Nos. 5,211,230 to Ostapovich et al. and 5,339,897 to Leaute describe a horizontal production well located in an oil-bearing reservoir. A vertical injection well is used to inject an oxidant gas into the reservoir for in situ combustion.

U.S. Patent No. 2,780,450 to Ljungstrom describes heating "in situ" (i.e., with the oil layers undisturbed in the ground) to convert or crack the thickly tar-like substance into valuable oils and gases.

U.S. Patent No. 4,597,441 to Ware et al. describes contacting oil, heat, and hydrogen simultaneously in a reservoir formation to effectively carry out hydrogenation and/or hydrogenolysis to enhance recovery of the oil.

U.S. Patent No. 5,046,559 to Glandt describes electrically preheating a portion of a tar sand formation between an injector well and a producer well. Steam is injected into the formation to produce hydrocarbons.

U.S. Patent No. 5,060,726 to Glandt et al. describes an apparatus and method for producing thick tar sand deposits by preheating of thin, relatively highly conductive layers with horizontal electrodes and steam stimulation. The preheating is continued until the viscosity of the tar in a thin preheated zone adjacent to the

highly conductive layers is reduced sufficiently to allow steam injection into the tar sand deposit. The entire deposit is then produced by steam flooding.

Many subsurface formations with heavy hydrocarbons are currently unusable for production of heavy hydrocarbons. This may be because the heavy hydrocarbons have too high a viscosity for normal production methods such as gas lifting and/or because methods for heating the heavy hydrocarbons are unreliable and/or not economically feasible. Thus, there is a need for reliable and economically feasible systems and methods for reducing the viscosity of heavy hydrocarbons so that the heavy hydrocarbons can be produced from subsurface formations that would not otherwise be used for heavy hydrocarbon production.

SUMMARY

The invention provides a method for treating a hydrocarbon containing formation comprising: applying electrical current to one or more electrical conductors located in an opening in the hydrocarbon containing formation to provide an electrically resistive heat output; allowing the heat to transfer from the electrical conductors to a part of the formation that contains hydrocarbons so that a viscosity of fluids in the part at or near the opening in the formation is reduced; providing gas at one or more locations in the opening to reduce the density of the fluids so that the fluids are lifted in the opening towards the surface of the formation by the formation pressure; and producing the fluids through the opening of the formation.

The invention also provides in combination with the above invention: (a) placing the one or more electrical conductors in the opening; (b) producing at least some fluids from the opening by pumping the fluids from the opening; (c) producing the fluids from the opening through a conduit located in the opening and/or providing the gas through one or more valves located along the conduit; and (d) limiting a temperature in the formation at or near the opening to at most 250 °C.

The invention also provides in combination with one or more of the above inventions that: (a) the viscosity of fluids at or near the opening is reduced to at most 0.05 Pa·s; (b) the gas comprises methane; and (c) the hydrocarbon containing formation is a relatively permeable formation containing heavy hydrocarbons.

The invention also provides in combination with one or more of the above inventions that: (a) at least one of the electrical conductors comprises an electrically resistive ferromagnetic material, at least one of the electrical conductors provides heat when electrical current flows through the one or more electrical conductors, and the one or more electrical conductors provide a reduced amount of heat above or near a selected temperature; and (b) the selected temperature is approximately the Curie temperature of the ferromagnetic material.

The invention also provides in combination with one or more of the above inventions: (a) applying AC or modulated DC to the one or more electrical conductors; (b) automatically providing the reduced amount of heat above or near the selected temperature; (c) providing an initial electrically resistive heat output when the electrical conductor providing the heat output is at least 50 °C below the selected temperature, and automatically providing the reduced amount of heat above or near the selected temperature; (d) providing a reduced amount of heat above or near the selected temperature of at most 200 W/m of length of the electrical conductor and/or providing a heat output below the selected temperature of at least 300 W/m of length of the electrical conductor; and (e) providing a heat output from at least one of the electrical conductors, wherein an electrical resistance of such electrical conductors above or near the selected temperature is 80% or less of the electrical resistance of such electrical conductors at 50 °C below the selected temperature.

In accordance with one aspect of the present invention, there is provided a method for treating a hydrocarbon containing formation, comprising: applying electrical current to one or more electrical conductors located in an opening in the formation to provide an electrically resistive heat output; allowing the heat to transfer from the electrical conductors to a part of the formation containing hydrocarbons so that a viscosity of hydrocarbons in the part and at or near the opening in the formation is reduced; providing gas at one or more locations in the opening to reduce the density of the hydrocarbons so that the hydrocarbons are lifted in the opening towards the surface of the formation by the formation pressure; and producing the hydrocarbons through the opening, characterized in that at least one of the electrical conductors comprises an electrically resistive ferromagnetic material and provides a reduced amount of heat above or near a Curie temperature of the ferromagnetic material, and that the produced hydrocarbons have an API gravity of 20 degrees or less.

BRIEF DESCRIPTION OF THE DRAWINGS

Advantages of the present invention will become apparent to those skilled in the art with the benefit of the following detailed description and upon reference to the accompanying drawings in which:

5 FIGS. 1 and 2 depict embodiments for heating and producing from the formation with the temperature limited heater in the production wellbore.

FIGS. 3 and 4 depict embodiments of the heating/production assembly that may be located in the wellbore for gas lifting.

FIG. 5 depicts an embodiment of a production conduit and a heater.

10 FIG. 6 depicts an embodiment for treating a formation.

FIG. 7 depicts an embodiment of a heater well with selective heating.

FIGS. 8, 9, and 10 depict cross-sectional representations of an embodiment of a temperature limited heater with an outer conductor having a ferromagnetic section and a non-ferromagnetic section.

15 FIGS. 11, 12, 13, and 14 depict cross-sectional representations of an embodiment of a temperature limited heater with an outer conductor having a ferromagnetic section and a non-ferromagnetic section placed inside a sheath.

FIGS. 15, 16, and 17 depict cross-sectional representations of an embodiment of a temperature limited heater with a ferromagnetic outer conductor.

20 FIGS. 18, 19, and 20 depict cross-sectional representations of an embodiment of a temperature limited heater with an outer conductor.

FIGS. 21, 22, 23, and 24 depict cross-sectional representations of an embodiment of a temperature limited heater.

FIGS. 25, 26, and 27 depict cross-sectional representations of an embodiment of a temperature limited heater with an overburden section and a heating section.

25 FIGS. 28A and 28B depict cross-sectional representations of an embodiment of a temperature limited heater with a ferromagnetic inner conductor.

FIGS. 29A and 29B depict cross-sectional representations of an embodiment of a temperature limited heater with a ferromagnetic inner conductor and a non-ferromagnetic core.

30 FIGS. 30A and 30B depict cross-sectional representations of an embodiment of a temperature limited heater with a ferromagnetic outer conductor.

FIGS. 31A and 31B depict cross-sectional representations of an embodiment of a temperature limited heater with a ferromagnetic outer conductor that is clad with a corrosion resistant alloy.

FIGS. 32A and 32B depict cross-sectional representations of an embodiment of a temperature limited heater with a ferromagnetic outer conductor.

35 FIG. 33 depicts a cross-sectional representation of an embodiment of a composite conductor with a support member.

FIG. 34 depicts an embodiment of a conductor-in-conduit temperature limited heater.

FIG. 35 depicts an embodiment of a temperature limited heater with a low temperature ferromagnetic outer conductor.

40 FIG. 36 depicts an embodiment of a temperature limited conductor-in-conduit heater.

FIGS. 37 and 38 depict cross-sectional representations of embodiments of conductor-in-conduit temperature limited heaters.

FIG. 39 depicts a cross-sectional representation of an embodiment of a conductor-in-conduit temperature limited heater with an insulated conductor.

5 While the invention is susceptible to various modifications and alternative forms, specific embodiments thereof are shown by way of example in the drawings and may herein be described in detail. The drawings may not be to scale. It should be understood, however, that the drawings and detailed description thereto are not intended to limit the invention to the particular form disclosed, but on the contrary, the intention is to cover all modifications, equivalents and alternatives falling within the spirit and scope of the present invention as defined
10 by the appended claims.

DETAILED DESCRIPTION

The above problems may be addressed using systems, methods, and heaters described herein. For example, a method for treating a hydrocarbon containing formation includes applying electrical current to one or more electrical conductors located in an opening in the formation to provide an electrically resistive heat output.
15 The method further includes allowing the heat to transfer from the electrical conductors to a part of the formation containing hydrocarbons so that a viscosity of fluids in the part and at or near the opening in the formation is reduced. The method further includes providing a gas at one or more locations in the opening to reduce the density of the fluids so that the fluids are lifted in the opening towards the surface of the formation by the formation pressure. The fluids are produced through the opening.

20 The following description generally relates to systems and methods for treating hydrocarbons in the formations. Such formations may be treated to yield hydrocarbon products, hydrogen, and other products.

“Hydrocarbons” are generally defined as molecules formed primarily by carbon and hydrogen atoms. Hydrocarbons may also include other elements such as, but not limited to, halogens, metallic elements, nitrogen, oxygen, and/or sulfur. Hydrocarbons may be, but are not limited to, kerogen, bitumen, pyrobitumen, oils,
25 natural mineral waxes, and asphaltites. Hydrocarbons may be located in or adjacent to mineral matrices in the earth. Matrices may include, but are not limited to, sedimentary rock, sands, silicilytes, carbonates, diatomites, and other porous media. “Hydrocarbon fluids” are fluids that include hydrocarbons. Hydrocarbon fluids may include, entrain, or be entrained in non-hydrocarbon fluids (for example, hydrogen, nitrogen, carbon monoxide, carbon dioxide, hydrogen sulfide, water, and ammonia).

30 A “formation” includes one or more hydrocarbon containing layers, one or more non-hydrocarbon layers, an overburden, and/or an underburden. The overburden and/or the underburden may include rock, shale, mudstone, or wet/tight carbonate. In some embodiments of in situ conversion processes, the overburden and/or the underburden may include a hydrocarbon containing layer or hydrocarbon containing layers that are relatively impermeable and are not subjected to temperatures during in situ conversion processing that results in
35 significant characteristic changes of the hydrocarbon containing layers of the overburden and/or the underburden. For example, the underburden may contain shale or mudstone, but the underburden is not allowed to heat to pyrolysis temperatures during the in situ conversion process. In some cases, the overburden and/or the underburden may be somewhat permeable.

“Formation fluids” and “produced fluids” refer to fluids removed from the formation and may include pyrolyzation fluid, synthesis gas, mobilized hydrocarbon, and water (steam). Formation fluids may include hydrocarbon fluids as well as non-hydrocarbon fluids.

5 A “heat source” is any system for providing heat to at least a portion of the formation substantially by conductive and/or radiative heat transfer.

A “heater” is any system for generating heat in a well or a near wellbore region. Heaters may be, but are not limited to, electric heaters, circulated heat transfer fluid or steam, burners, combustors that react with material in or produced from the formation, and/or combinations thereof. The term “wellbore” refers to a hole in the formation made by drilling or insertion of a conduit into the formation. As used herein, the terms “well” and “opening”, when referring to an opening in the formation, may be used interchangeably with the term “wellbore”.

“Insulated conductor” refers to any elongated material that is able to conduct electricity and that is covered, in whole or in part, by an electrically insulating material. The term “self-controls” refers to controlling an output of a heater without external control of any type.

15 “Pyrolysis” is the breaking of chemical bonds due to the application of heat. Pyrolysis includes transforming a compound into one or more other substances by heat alone. Heat may be transferred to a section of the formation to cause pyrolysis. “Pyrolyzation fluids” or “pyrolysis products” refers to fluid produced during pyrolysis of hydrocarbons. Fluid produced by pyrolysis reactions may mix with other fluids in the formation. The mixture would be considered pyrolyzation fluid or pyrolyzation product. Pyrolyzation fluids include, but are not limited to, hydrocarbons, hydrogen, carbon dioxide, carbon monoxide, hydrogen sulfide, ammonia, nitrogen, water, and mixtures thereof.

20 “Condensable hydrocarbons” are hydrocarbons that condense at 25 °C and 101 kPa absolute pressure. Condensable hydrocarbons may include a mixture of hydrocarbons having carbon numbers greater than 4. “Non-condensable hydrocarbons” are hydrocarbons that do not condense at 25 °C and 101 kPa absolute pressure. Non-condensable hydrocarbons may include hydrocarbons having carbon numbers less than 5.

“Heavy hydrocarbons” are viscous hydrocarbon fluids. Heavy hydrocarbons may include highly viscous hydrocarbon fluids such as heavy oil, tar, and/or asphalt. Heavy hydrocarbons may include carbon and hydrogen, as well as smaller concentrations of sulfur, oxygen, and nitrogen. Additional elements may also be present in heavy hydrocarbons in trace amounts. Heavy hydrocarbons may be classified by API gravity. Heavy hydrocarbons generally have an API gravity below 20°. Heavy oil, for example, generally has an API gravity of 10-20°, whereas tar generally has an API gravity below 10°. The viscosity of heavy hydrocarbons is generally at least 0.1 Pa·s (Pascal-second) at 15 °C. Heavy hydrocarbons may also include aromatics or other complex ring hydrocarbons.

35 Heavy hydrocarbons may be found in a relatively permeable formation. The relatively permeable formation may include heavy hydrocarbons entrained in, for example, sand or carbonate. “Relatively permeable” is defined, with respect to formations or portions thereof, as an average permeability of 10 millidarcy or more (for example, 10 millidarcy, 100 millidarcy, or 1000 millidarcy). “Relatively low permeability” is defined, with respect to formations or portions thereof, as an average permeability of at most 10 millidarcy. One darcy is equal to 0.99 square micrometers. An impermeable layer generally has a permeability of at most 0.1 millidarcy.

“Tar” is a viscous hydrocarbon that generally has a viscosity at least 10 Pa·s at 15 °C. The specific gravity of tar generally is at least 1.000. Tar may have an API gravity of at most 10°.

A “tar sands formation” is a formation in which hydrocarbons are predominantly present in the form of heavy hydrocarbons and/or tar entrained in a mineral grain framework or other host lithology (for example, sand or carbonate).

In some cases, some or all of a hydrocarbon portion of the relatively permeable formation may be predominantly heavy hydrocarbons and/or tar with no supporting mineral grain framework and only floating (or no) mineral matter (for example, asphalt lakes).

“Superposition of heat” refers to providing heat from two or more heat sources to a selected section of a formation such that the temperature of the formation at least at one location between the heat sources is influenced by the heat sources.

“Curie temperature” is the temperature above which a ferromagnetic material loses all of its ferromagnetic properties.

“Modulated direct current (DC)” refers to any time-varying current that allows for skin effect electricity flow in a ferromagnetic conductor.

“Turndown ratio” for the temperature limited heater is the ratio of the highest AC or modulated DC resistance below the Curie temperature to the lowest resistance for a given current above the Curie temperature.

In the context of reduced heat output heating systems, apparatus, and methods, the term “automatically” means such systems and apparatus function in a certain way without the use of external control (for example, external controllers such as a controller with a temperature sensor and a feedback loop, PID controller, or predictive controller).

“Temperature limited heater” generally refers to a heater that regulates heat output (for example, reduces heat output) above a specified temperature without the use of external controls such as temperature controllers, power regulators, rectifiers, or other devices. Temperature limited heaters may be AC (alternating current) or modulated (for example, “chopped”) DC (direct current) powered electrical resistance heaters.

A heat source may heat a volume of formation adjacent to a production wellbore (a near production wellbore region) so that the temperature of fluid in the production wellbore and in the volume adjacent to the production wellbore is less than the temperature that causes degradation of the fluid. The heat source may be located in the production wellbore or near the production wellbore. In some embodiments, the heat source is a temperature limited heater. In some embodiments, two or more heat sources may supply heat to the volume. Heat from the heat source may reduce the viscosity of crude oil in or near the production wellbore. In some embodiments, heat from the heat source mobilizes fluids in or near the production wellbore and/or enhances the radial flow of fluids to the production wellbore. In some embodiments, reducing the viscosity of crude oil allows or enhances gas lifting of heavy oil or intermediate gravity oil (approximately 12° to 20° API gravity oil) from the production wellbore. In certain embodiments, the viscosity of oil in the formation is at least 0.05 Pa·s. Large amounts of natural gas may have to be utilized to provide gas lift of oil with viscosities above 0.05 Pa·s. Reducing the viscosity of oil at or near the production wellbore in the formation to a viscosity of 0.03 Pa·s or less (down to 0.001 Pa·s or lower) lowers the amount of natural gas needed to lift oil from the formation. In some embodiments, reduced viscosity oil is produced by other methods such as pumping.

The rate of production of oil from the formation may be increased by raising the temperature at or near a production wellbore to reduce the viscosity of the oil in the formation in and adjacent to the production wellbore. In certain embodiments, the rate of production of oil from the formation is increased by 2 times, 3 times, 4 times, or greater up to 20 times over standard cold production, which has no external heating of formation during production. Certain formations may be more economically viable for enhanced oil production using the heating of the near production wellbore region. Formations that have a cold production rate approximately between $0.05 \text{ m}^3/(\text{day per meter of wellbore length})$ and $0.20 \text{ m}^3/(\text{day per meter of wellbore length})$ may have significant improvements in production rate using heating to reduce the viscosity in the near production wellbore region. In some formations, production wells up to 775 m, up to 1000 m, or up to 1500 m in length are used. For example, production wells between 450 m and 775 m in length are used, between 550 m and 800 m are used, or between 650 m and 900 m are used. Thus, a significant increase in production is achievable in some formations. Heating the near production wellbore region may be used in formations where the cold production rate is not between $0.05 \text{ m}^3/(\text{day per meter of wellbore length})$ and $0.20 \text{ m}^3/(\text{day per meter of wellbore length})$, but heating such formations may not be as economically favorable. Higher cold production rates may not be significantly increased by heating the near wellbore region, while lower production rates may not be increased to an economically useful value.

Using the temperature limited heater to reduce the viscosity of oil at or near the production well inhibits problems associated with non-temperature limited heaters and heating the oil in the formation due to hot spots. One possible problem is that non-temperature limited heaters can causing coking of oil at or near the production well if the heater overheats the oil because the heaters are at too high a temperature. Higher temperatures in the production well may also cause brine to boil in the well, which may lead to scale formation in the well. Non-temperature limited heaters that reach higher temperatures may also cause damage to other wellbore components (for example, screens used for sand control, pumps, or valves). Hot spots may be caused by portions of the formation expanding against or collapsing on the heater. In some embodiments, the heater (either the temperature limited heater or another type of non-temperature limited heater) has sections that are lower because of sagging over long heater distances. These lower sections may sit in heavy oil or bitumen that collects in lower portions of the wellbore. At these lower sections, the heater may develop hot spots due to coking of the heavy oil or bitumen. A standard non-temperature limited heater may overheat at these hot spots, thus producing a non-uniform amount of heat along the length of the heater. Using the temperature limited heater may inhibit overheating of the heater at hot spots or lower sections and provide more uniform heating along the length of the wellbore.

In some embodiments, oil or bitumen cokes in a perforated liner or screen in a heater/production wellbore (for example, coke may form between the heater and the liner or between the liner and the formation). Oil or bitumen may also coke in a toe section of a heel and toe heater/production wellbore, as shown in and described below for FIG. 7. A temperature limited heater may limit a temperature of a heater/production wellbore below a coking temperature to inhibit coking in the well so that production in the wellbore does not plug up.

FIG. 1 depicts an embodiment for heating and producing from the formation with the temperature limited heater in a production wellbore. Production conduit 100 is located in wellbore 102. In certain embodiments, a portion of wellbore 102 is located substantially horizontally in formation 104. In some

embodiments, the wellbore is located substantially vertically in the formation. In an embodiment, wellbore 102 is an open wellbore (an uncased wellbore). In some embodiments, the wellbore has a casing or walls that have perforations or openings to allow fluid to flow into the wellbore.

Conduit 100 may be made from carbon steel or more corrosion resistant materials such as stainless steel. Conduit 100 may include apparatus and mechanisms for gas lifting or pumping produced oil to the surface. For example, conduit 100 includes gas lift valves used in a gas lift process. Examples of gas lift control systems and valves are disclosed in U.S. Patent No. 6,715,550 to Vinegar et al. and U.S. Patent Application Publication Nos. 2002-0036085 to Bass et al. and 2003-0038734 to Hirsch et al. Conduit 100 may include one or more openings (perforations) to allow fluid to flow into the production conduit. In certain embodiments, the openings in conduit 100 are in a portion of the conduit that remains below the liquid level in wellbore 102. For example, the openings are in a horizontal portion of conduit 100.

Heater 106 is located in conduit 100, as shown in FIG. 1. In some embodiments, heater 106 is located outside conduit 100, as shown in FIG. 2. The heater located outside the production conduit may be coupled (strapped) to the production conduit. In some embodiments, more than one heater (for example, two, three, or four heaters) are placed about conduit 100. The use of more than one heater may reduce bowing or flexing of the production conduit caused by heating on only one side of the production conduit. In an embodiment, heater 106 is a temperature limited heater. Heater 106 provides heat to reduce the viscosity of fluid (such as oil or hydrocarbons) in and near wellbore 102. In certain embodiments, heater 106 raises the temperature of the fluid in wellbore 102 up to a temperature of 250 °C or less (for example, 225 °C, 200 °C, or 150 °C). Heater 106 may be at higher temperatures (for example, 275 °C, 300 °C, or 325 °C) because the heater radiates heat to conduit 100 and there is some temperature loss between the heater and the conduit. Thus, heat produced from the heater does not raise the temperature of fluids in the wellbore above 250 °C.

In certain embodiments, heater 106 includes ferromagnetic materials such as Carpenter Temperature Compensator "32", Alloy 42-6, Alloy 52, Invar 36, or other iron-nickel or iron-nickel-chromium alloys. In certain embodiments, nickel or nickel-chromium alloys are used in heater 106. In some embodiments, heater 106 includes a composite conductor with a more highly conductive material such as copper on the inside of the heater to improve the turndown ratio of the heater. Heat from heater 106 heats fluids in or near wellbore 102 to reduce the viscosity of the fluids and increase a production rate through conduit 100.

In certain embodiments, portions of heater 106 above the liquid level in wellbore 102 (such as the vertical portion of the wellbore depicted in FIGS. 1 and 2) have a lower maximum temperature than portions of the heater located below the liquid level. For example, portions of heater 106 above the liquid level in wellbore 102 may have a maximum temperature of 100 °C while portions of the heater located below the liquid level have a maximum temperature of 250 °C. In certain embodiments, such a heater includes two or more ferromagnetic sections with different Curie temperatures to achieve the desired heating pattern. Providing less heat to portions of wellbore 102 above the liquid level and closer to the surface may save energy.

In certain embodiments, heater 106 is electrically isolated on the heater's outside surface and allowed to move freely in conduit 100. For example, heater 106 may include a furnace cable inner conductor. In some embodiments, electrically insulating centralizers are placed on the outside of heater 106 to maintain a gap between conduit 100 and the heater. Centralizers are made of alumina, gas pressure sintered reaction bonded silicon nitride, or boron nitride, other electrically insulating and thermally resistant material, and/or

combinations thereof. In some embodiments, heater 106 is electrically coupled to conduit 100 so that an electrical circuit is completed with the conduit. For example, an alternating current voltage may be applied to heater 106 and conduit 100 so that alternating current flows down the outer surface of the heater and returns to a wellhead on the inside surface of the production conduit. Heater 106 and conduit 100 may include
5 ferromagnetic materials so that the alternating current is confined substantially to a skin depth on the outside of the heater and/or a skin depth on the inside of the production conduit. A sliding connector may be located at or near the bottom of conduit 100 to electrically couple the production conduit and heater 106.

In some embodiments, heater 106 is cycled (turned on and off) so that fluids produced through conduit 100 are not overheated. In an embodiment, heater 106 is turned on for a specified amount of time until a
10 temperature of fluids in or near wellbore 102 reaches a desired temperature (for example, the maximum temperature of the heater). During the heating time (for example, 10 days, 20 days, or 30 days), production through conduit 100 may be stopped to allow fluids in the formation to "soak" and obtain a reduced viscosity. After heating is turned off or reduced, production through conduit 100 is started and fluids from the formation are produced without excess heat being provided to the fluids. During production, fluids in or near wellbore 102
15 will cool down without heat from heater 106 being provided. When the fluids reach a temperature at which production significantly slows down, production is stopped and heater 106 is turned back on to reheat the fluids. This process may be repeated until a desired amount of production is reached. In some embodiments, some heat at a lower temperature is provided to maintain a flow of the produced fluids. For example, low temperature heat (for example, 100 °C, 125 °C, or 150 °C) may be provided in the upper portions of wellbore 102 to keep fluids
20 from cooling to a lower temperature.

FIG. 3 depicts an embodiment of a heating/production assembly that may be located in a wellbore for gas lifting. Heating/production assembly 108 may be located in a wellbore in the formation (for example, wellbore 102 depicted in FIGS. 1 or 2). Conduit 100 is located inside casing 110. In an embodiment, conduit 100 is coiled tubing such as 6 cm diameter coiled tubing. Casing 110 has a diameter between 10 cm and 25 cm
25 (for example, a diameter of 14 cm, 16 cm, or 18 cm). Heater 106 is coupled to an end of conduit 100. In some embodiments, heater 106 is located inside conduit 100. In some embodiments, heater 106 is a resistive portion of conduit 100. In some embodiments, heater 106 is coupled to a length of conduit 100.

Opening 112 is located at or near a junction of heater 106 and conduit 100. In some embodiments, opening 112 is a slot or a slit in conduit 100. In some embodiments, opening 112 includes more than one
30 opening in conduit 100. Opening 112 allows production fluids to flow into conduit 100 from a wellbore. Perforated casing 114 allows fluids to flow into the heating/production assembly 108. In certain embodiments, perforated casing 114 is a wire wrapped screen. In one embodiment, perforated casing 114 is a 9 cm diameter wire wrapped screen.

Perforated casing 114 may be coupled to casing 110 with packing material 116. Packing material 116
35 inhibits fluids from flowing into casing 110 from outside perforated casing 114. Packing material 116 may also be placed inside casing 110 to inhibit fluids from flowing up the annulus between the casing and conduit 100. Seal assembly 118 is used to seal conduit 100 to packing material 116. Seal assembly 118 may fix a position of conduit 100 along a length of a wellbore. In some embodiments, seal assembly 118 allows for unsealing of conduit 100 so that the production conduit and heater 106 may be removed from the wellbore.

Feedthrough 120 is used to pass lead-in cable 122 to supply power to heater 106. Lead-in cable 122 may be secured to conduit 100 with clamp 124. In some embodiments, lead-in cable 122 passes through packing material 116 using a separate feedthrough.

5 A lifting gas (for example, natural gas, methane, carbon dioxide, propane, and/or nitrogen) may be provided to the annulus between conduit 100 and casing 110. Valves 126 are located along a length of conduit 100 to allow gas to enter the production conduit and provide for gas lifting of fluids in the production conduit. The lifting gas may mix with fluids in conduit 100 to lower the density of the fluids and allow for gas lifting of the fluids out of the formation. In certain embodiments, valves 126 are located in an overburden section of a formation so that gas lifting is provided in the overburden section. In some embodiments, fluids are produced
10 through the annulus between conduit 100 and casing 110 and a lifting gas may be supplied through valves 126.

In an embodiment, fluids are produced using a pump coupled to conduit 100. The pump may be a submersible pump (for example, an electric or gas powered submersible pump). In some embodiments, a heater is coupled to conduit 100 to maintain the reduced viscosity of fluids in the conduit and/or the pump.

15 In certain embodiments, an additional conduit such as an additional coiled tubing conduit is placed in the formation. Sensors may be placed in the additional conduit. For example, a production logging tool may be placed in the additional conduit to identify locations of producing zones and/or to assess flow rates. In some embodiments, a temperature sensor (for example, a distributed temperature sensor, a fiber optic sensor, and/or an array of thermocouples) is placed in the additional conduit to determine a subsurface temperature profile.

20 Some embodiments of the heating/production assembly are used in a well that preexists (for example, the heating/production assembly is retrofitted for a preexisting production well, heater well, or monitoring well). An example of the heating/production assembly that may be used in the preexisting well is depicted in FIG. 4. Some preexisting wells include a pump. The pump in the preexisting well may be left in the heating/production well retrofitted with the heating/production assembly.

25 FIG. 4 depicts an embodiment of the heating/production assembly that may be located in the wellbore for gas lifting. In FIG. 4, conduit 100 is located in outside production conduit 128. In an embodiment, outside production conduit 128 is 11.4 cm diameter production tubing. Casing 110 has a diameter of 24.4 cm. Perforated casing 114 has a diameter of 11.4 cm. Seal assembly 118 seals conduit 100 inside outside production conduit 128. In an embodiment, pump 130 is a jet pump such as a bottomhole assembly jet pump.

30 In some embodiments, heat is inhibited from transferring into conduit 100. FIG. 5 depicts an embodiment of conduit 100 and heaters 106 that inhibit heat transfer into the conduit. Heaters 106 are coupled to conduit 100. Heaters 106 include ferromagnetic sections 132 and non-ferromagnetic sections 134. Ferromagnetic sections 132 provide heat at a temperature that reduces the viscosity of fluids in or near a wellbore. Non-ferromagnetic sections 134 provide little or no heat. In certain embodiments, ferromagnetic sections 132 and non-ferromagnetic sections 134 are 6 m in length. In some embodiments, ferromagnetic
35 sections 132 and non-ferromagnetic sections 134 are between 3 m and 12 m in length, between 4 m and 11 m in length, or between 5 m and 10 m in length. In certain embodiments, non-ferromagnetic sections 134 include perforations 136 to allow fluids to flow to conduit 100. In some embodiments, heater 106 is positioned so that perforations are not needed to allow fluids to flow to conduit 100.

40 Conduit 100 may have perforations 136 to allow fluid to enter the conduit. Perforations 136 coincide with non-ferromagnetic sections 134 of heater 106. Sections of conduit 100 that coincide with ferromagnetic

sections 132 include insulation conduit 138. Conduit 138 may be a vacuum insulated tubular. For example, conduit 138 may be a vacuum insulated production tubular available from Oil Tech Services, Inc. (Houston, TX). Conduit 138 inhibits heat transfer into conduit 100 from ferromagnetic sections 132. Limiting the heat transfer into conduit 100 reduces heat loss and/or inhibits overheating of fluids in the conduit. In an
5 embodiment, heater 106 provides heat along an entire length of the heater and conduit 100 includes conduit 138 along an entire length of the production conduit.

In certain embodiments, more than one wellbore 102 is used to produce heavy oils from a formation using the temperature limited heater. FIG. 6 depicts an end view of an embodiment with wellbores 102 located in hydrocarbon layer 140. A portion of wellbores 102 are placed substantially horizontally in a triangular
10 pattern in hydrocarbon layer 140. In certain embodiments, wellbores 102 have a spacing of 30 m to 60 m, 35 m to 55 m, or 40 m to 50 m. Wellbores 102 may include production conduits and heaters previously described. Fluids may be heated and produced through wellbores 102 at an increased production rate above a cold production rate for the formation. Production may continue for a selected time (for example, 5 years to 10 years, 6 years to 9 years, or 7 years to 8 years) until heat produced from each of wellbores 102 begins to overlap
15 (i.e., superposition of heat begins). At such a time, heat from lower wellbores (such as wellbores 102 near the bottom of hydrocarbon layer 140) is continued, reduced, or turned off while production is continued. Production in upper wellbores (such as wellbores 102 near the top of hydrocarbon layer 140) may be stopped so that fluids in the hydrocarbon layer drain towards the lower wellbores. In some embodiments, power is increased to the upper wellbores and the temperature raised above the Curie temperature to increase the heat
20 injection rate. Draining fluids in the formation in such a process increases total hydrocarbon recovery from the formation.

In an embodiment, a temperature limited heater is used in a horizontal heater/production well. The temperature limited heater may provide selected amounts of heat to the "toe" and the "heel" of the horizontal portion of the well. More heat may be provided to the formation through the toe than through the heel, creating
25 a "hot portion" at the toe and a "warm portion" at the heel. Formation fluids may be formed in the hot portion and produced through the warm portion, as shown in FIG. 7.

FIG. 7 depicts an embodiment of a heater well for selectively heating a formation. Heat source 142 is placed in opening 144 in hydrocarbon layer 140. In certain embodiments, opening 144 is a substantially horizontal opening in hydrocarbon layer 140. Perforated casing 114 is placed in opening 144. Perforated casing
30 114 provides support that inhibits hydrocarbon and/or other material in hydrocarbon layer 140 from collapsing into opening 144. Perforations in perforated casing 114 allow for fluid flow from hydrocarbon layer 140 into opening 144. Heat source 142 may include hot portion 146. Hot portion 146 is a portion of heat source 142 that operates at higher heat output than adjacent portions of the heat source. For example, hot portion 146 may output between 650 W/m and 1650 W/m, 650 W/m and 1500 W/m, or 800 W/m and 1500 W/m. Hot portion
35 146 may extend from a "heel" of the heat source to the "toe" of the heat source. The heel of the heat source is the portion of the heat source closest to the point at which the heat source enters a hydrocarbon layer. The toe of the heat source is the end of the heat source furthest from the entry of the heat source into a hydrocarbon layer.

In an embodiment, heat source 142 includes warm portion 148. Warm portion 148 is a portion of heat source 142 that operates at lower heat outputs than hot portion 146. For example, warm portion 148 may output
40 between 30 W/m and 1000 W/m, 30 W/m and 750 W/m, or 100 W/m and 750 W/m. Warm portion 148 may be

located closer to the heel of heat source 142. In certain embodiments, warm portion 148 is a transition portion (for example, a transition conductor) between hot portion 146 and overburden portion 150. Overburden portion 150 is located in overburden 152. Overburden portion 150 provides a lower heat output than warm portion 148. For example, overburden portion 150 may output between 10 W/m and 90 W/m, 15 W/m and 80 W/m, or 25
5 W/m and 75 W/m. In some embodiments, overburden portion 150 provides as close to no heat (0 W/m) as possible to overburden 152. Some heat, however, may be used to maintain fluids produced through opening 144 in a vapor phase in overburden 152.

In certain embodiments, hot portion 146 of heat source 142 heats hydrocarbons to high enough temperatures to result in coke 154 forming in hydrocarbon layer 140. Coke 154 may occur in an area
10 surrounding opening 144. Warm portion 148 may be operated at lower heat outputs so that coke does not form at or near the warm portion of heat source 142. Coke 154 may extend radially from opening 144 as heat from heat source 142 transfers outward from the opening. At a certain distance, however, coke 154 no longer forms because temperatures in hydrocarbon layer 140 at the certain distance will not reach coking temperatures. The distance at which no coke forms is a function of heat output (W/m from heat source 142), type of formation,
15 hydrocarbon content in the formation, and/or other conditions in the formation.

The formation of coke 154 inhibits fluid flow into opening 144 through the coking. Fluids in the formation may, however, be produced through opening 144 at the heel of heat source 142 (for example, at warm portion 148 of the heat source) where there is little or no coke formation. The lower temperatures at the heel of heat source 142 reduce the possibility of increased cracking of formation fluids produced through the heel.

20 Fluids may flow in a horizontal direction through the formation more easily than in a vertical direction.

Typically, horizontal permeability in a relatively permeable formation is approximately 5 to 10 times greater than vertical permeability. Thus, fluids flow along the length of heat source 142 in a substantially horizontal direction. Producing formation fluids through opening 144 is possible at earlier times than producing fluids through production wells in hydrocarbon layer 140. The earlier production times through opening 144 is
25 possible because temperatures near the opening increase faster than temperatures further away due to conduction of heat from heat source 142 through hydrocarbon layer 140. Early production of formation fluids may be used to maintain lower pressures in hydrocarbon layer 140 during start-up heating of the formation. Start-up heating of the formation is the time of heating before production begins at production wells in the formation. Lower pressures in the formation may increase liquid production from the formation. In addition,
30 producing formation fluids through opening 144 may reduce the number of production wells needed in the formation.

Some embodiments of heaters include switches (for example, fuses and/or thermostats) that turn off power to the heater or portions of the heater when a certain condition is reached in the heater. In certain
35 embodiments, a "temperature limited heater" is used to provide heat to the formation. The temperature limited heater is a heater that regulates heat output (for example, reduces heat output) above a specified temperature without the use of external controls such as temperature controllers, power regulators, rectifiers or other devices. Temperature limited heaters may be AC (alternating current) or modulated (for example, "chopped") DC (direct current) powered electrical resistance heaters.

40 Temperature limited heaters may be in configurations and/or may include materials that provide automatic temperature limiting properties for the heater at certain temperatures. In certain embodiments,

ferromagnetic materials are used in temperature limited heaters. Ferromagnetic material may self-limit temperature at or near the Curie temperature of the material to provide a reduced amount of heat at or near the Curie temperature when an alternating current is applied to the material. In certain embodiments, ferromagnetic materials are coupled with other materials (for example, highly conductive materials, high strength materials, corrosion resistant materials, or combinations thereof) to provide various electrical and/or mechanical properties. Some parts of the temperature limited heater may have a lower resistance (caused by different geometries and/or by using different ferromagnetic and/or non-ferromagnetic materials) than other parts of the temperature limited heater. Having parts of the temperature limited heater with various materials and/or dimensions allows for tailoring the desired heat output from each part of the heater. Using ferromagnetic materials in temperature limited heaters is typically less expensive and more reliable than using switches or other control devices in temperature limited heaters.

Temperature limited heaters may be more reliable than other heaters. Temperature limited heaters may be less apt to break down or fail due to hot spots in the formation. In some embodiments, temperature limited heaters allow for substantially uniform heating of the formation. In some embodiments, temperature limited heaters are able to heat the formation more efficiently by operating at a higher average heat output along the entire length of the heater. The temperature limited heater operates at the higher average heat output along the entire length of the heater because power to the heater does not have to be reduced to the entire heater, as is the case with typical constant wattage heaters, if a temperature along any point of the heater exceeds, or is about to exceed, a maximum operating temperature of the heater. Heat output from portions of a temperature limited heater approaching a Curie temperature of the heater is automatically reduced without controlled adjustment of alternating current applied to the heater. The heat output is automatically reduced due to changes in electrical properties (for example, electrical resistance) of portions of the temperature limited heater. Thus, more heat is supplied by the temperature limited heater during a greater portion of a heating process.

In an embodiment, the system including temperature limited heaters initially provides a first heat output and then provides a reduced amount of heat, near, at, or above the Curie temperature of an electrically resistive portion of the heater when the temperature limited heater is energized by an alternating current or a modulated direct current. The temperature limited heater may be energized by alternating current or modulated direct current supplied at the wellhead. The wellhead may include a power source and other components (for example, modulation components, transformers, and/or capacitors) used in supplying power to the temperature limited heater. The temperature limited heater may be one of many heaters used to heat a portion of the formation.

In certain embodiments, the temperature limited heater includes a conductor that operates as a skin effect or proximity effect heater when alternating current or modulated direct current is applied to the conductor. The skin effect limits the depth of current penetration into the interior of the conductor. For ferromagnetic materials, the skin effect is dominated by the magnetic permeability of the conductor. The relative magnetic permeability of ferromagnetic materials is typically between 10 and 1000 (for example, the relative magnetic permeability of ferromagnetic materials is typically at least 10 and may be at least 50, 100, 500, 1000 or greater). As the temperature of the ferromagnetic material is raised above the Curie temperature and/or as the applied electrical current is increased, the magnetic permeability of the ferromagnetic material decreases substantially and the skin depth expands rapidly (for example, the skin depth expands as the inverse square root

of the magnetic permeability). The reduction in magnetic permeability results in a decrease in the AC or modulated DC resistance of the conductor near, at, or above the Curie temperature and/or as the applied electrical current is increased. When the temperature limited heater is powered by a substantially constant current source, portions of the heater that approach, reach, or are above the Curie temperature may have reduced heat dissipation. Sections of the temperature limited heater that are not at or near the Curie temperature may be dominated by skin effect heating that allows the heater to have high heat dissipation due to a higher resistive load.

An advantage of using the temperature limited heater to heat hydrocarbons in the formation is that the conductor is chosen to have a Curie temperature in a desired range of temperature operation. Operation within the desired operating temperature range allows substantial heat injection into the formation while maintaining the temperature of the temperature limited heater, and other equipment, below design limit temperatures. Design limit temperatures are temperatures at which properties such as corrosion, creep, and/or deformation are adversely affected. The temperature limiting properties of the temperature limited heater inhibit overheating or burnout of the heater adjacent to low thermal conductivity "hot spots" in the formation. In some embodiments, the temperature limited heater is able to lower or control heat output and/or withstand heat at temperatures above 25 °C, 37 °C, 100 °C, 250 °C, 500 °C, 700 °C, 800 °C, 900 °C, or higher, up to 1131 °C, depending on the materials used in the heater.

The use of temperature limited heaters allows for efficient transfer of heat to the formation. Efficient transfer of heat allows for reduction in time needed to heat the formation to a desired temperature. For example, in Green River oil shale, pyrolysis typically requires 9.5 years to 10 years of heating when using a 12 m heater well spacing with conventional constant wattage heaters. For the same heater spacing, temperature limited heaters may allow a larger average heat output while maintaining heater equipment temperatures below equipment design limit temperatures. Pyrolysis in the formation may occur at an earlier time with the larger average heat output provided by temperature limited heaters than the lower average heat output provided by constant wattage heaters. For example, in Green River oil shale, pyrolysis may occur in 5 years using temperature limited heaters with a 12 m heater well spacing. Temperature limited heaters counteract hot spots due to inaccurate well spacing or drilling where heater wells come too close together. In certain embodiments, temperature limited heaters allow for increased power output over time for heater wells that have been spaced too far apart, or limit power output for heater wells that are spaced too close together. Temperature limited heaters also supply more power in regions adjacent the overburden and underburden to compensate for temperature losses in the regions.

The ferromagnetic alloy or ferromagnetic alloys used in the temperature limited heater determine the Curie temperature of the heater. Curie temperature data for various metals is listed in "American Institute of Physics Handbook," Second Edition, McGraw-Hill, pages 5-170 through 5-176. Ferromagnetic conductors may include one or more of the ferromagnetic elements (iron, cobalt, and nickel) and/or alloys of these elements. In some embodiments, ferromagnetic conductors include iron-chromium (Fe-Cr) alloys that contain tungsten (W) (for example, HCM12A and SAVE12 (Sumitomo Metals Co., Japan) and/or iron alloys that contain chromium (for example, Fe-Cr alloys, Fe-Cr-W alloys, Fe-Cr-V (vanadium) alloys, Fe-Cr-Nb (Niobium) alloys). Of the three main ferromagnetic elements, iron has a Curie temperature of approximately 770 °C; cobalt (Co) has a Curie temperature of approximately 1131 °C; and nickel has a Curie temperature of approximately 358 °C. An

iron-cobalt alloy has a Curie temperature higher than the Curie temperature of iron. For example, iron-cobalt alloy with 2% by weight cobalt has a Curie temperature of approximately 800 °C; iron-cobalt alloy with 12% by weight cobalt has a Curie temperature of approximately 900 °C; and iron-cobalt alloy with 20% by weight cobalt has a Curie temperature of approximately 950 °C. Iron-nickel alloy has a Curie temperature lower than the Curie temperature of iron. For example, iron-nickel alloy with 20% by weight nickel has a Curie temperature of approximately 720 °C, and iron-nickel alloy with 60% by weight nickel has a Curie temperature of approximately 560 °C.

Some non-ferromagnetic elements used as alloys raise the Curie temperature of iron. For example, an iron-vanadium alloy with 5.9% by weight vanadium has a Curie temperature of approximately 815 °C. Other non-ferromagnetic elements (for example, carbon, aluminum, copper, silicon, and/or chromium) may be alloyed with iron or other ferromagnetic materials to lower the Curie temperature. Non-ferromagnetic materials that raise the Curie temperature may be combined with non-ferromagnetic materials that lower the Curie temperature and alloyed with iron or other ferromagnetic materials to produce a material with a desired Curie temperature and other desired physical and/or chemical properties. In some embodiments, the Curie temperature material is a ferrite such as NiFe_2O_4 . In other embodiments, the Curie temperature material is a binary compound such as FeNi_3 or Fe_3Al .

Magnetic properties generally decay as the Curie temperature is approached. The "Handbook of Electrical Heating for Industry" by C. James Erickson (IEEE Press, 1995) shows a typical curve for 1% carbon steel (steel with 1% carbon by weight). The loss of magnetic permeability starts at temperatures above 650 °C and tends to be complete when temperatures exceed 730 °C. Thus, the self-limiting temperature may be somewhat below the actual Curie temperature of the ferromagnetic conductor. The skin depth for current flow in 1% carbon steel is 0.132 cm (centimeters) at room temperature and increases to 0.445 cm at 720 °C. From 720 °C to 730 °C, the skin depth sharply increases to over 2.5 cm. Thus, a temperature limited heater embodiment using 1% carbon steel self-limits between 650 °C and 730 °C.

Skin depth generally defines an effective penetration depth of alternating current or modulated direct current into the conductive material. In general, current density decreases exponentially with distance from an outer surface to the center along the radius of the conductor. The depth at which the current density is approximately 1/e of the surface current density is called the skin depth. For a solid cylindrical rod with a diameter much greater than the penetration depth, or for hollow cylinders with a wall thickness exceeding the penetration depth, the skin depth, δ , is:

$$(1) \delta = 1981.5 * (\rho / (\mu * f))^{1/2};$$

in which: δ = skin depth in inches;
 ρ = resistivity at operating temperature (ohm-cm);
 μ = relative magnetic permeability; and
 f = frequency (Hz).

EQN. 1 is obtained from "Handbook of Electrical Heating for Industry" by C. James Erickson (IEEE Press, 1995). For most metals, resistivity (ρ) increases with temperature. The relative magnetic permeability generally varies with temperature and with current. Additional equations may be used to assess the variance of magnetic permeability and/or skin depth on both temperature and/or current. The dependence of μ on current arises from the dependence of μ on the magnetic field.

Materials used in the temperature limited heater may be selected to provide a desired turndown ratio. Turndown ratios of at least 1.1:1, 2:1, 3:1, 4:1, 5:1, 10:1, 30:1, or 50:1 may be selected for temperature limited heaters. Larger turndown ratios may also be used. The selected turndown ratio depends on a number of factors including, but not limited to, the type of formation in which the temperature limited heater is located and/or a temperature limit of materials used in the wellbore. In some embodiments, the turndown ratio is increased by coupling additional copper or another good electrical conductor to the ferromagnetic material (for example, adding copper to lower the resistance above the Curie temperature).

The temperature limited heater may provide a minimum heat output (power output) below the Curie temperature of the heater. In certain embodiments, the minimum heat output is at least 400 W/m (Watts per meter), 600 W/m, 700 W/m, 800 W/m, or higher, up to 2000 W/m. The temperature limited heater reduces the amount of heat output by a section of the heater when the temperature of the section of the heater approaches or is above the Curie temperature. The reduced amount of heat may be substantially less than the heat output below the Curie temperature. In some embodiments, the reduced amount of heat is at most 400 W/m, 200 W/m, or 100 W/m, or may approach 0 W/m.

In some embodiments, the temperature limited heater may operate substantially independently of the thermal load on the heater in a certain operating temperature range. "Thermal load" is the rate that heat is transferred from a heating system to its surroundings. It is to be understood that the thermal load may vary with temperature of the surroundings and/or the thermal conductivity of the surroundings. In an embodiment, the temperature limited heater operates at or above the Curie temperature of the temperature limited heater such that the operating temperature of the heater increases at most by 1.5 °C, 1 °C, or 0.5 °C for a decrease in thermal load of 1 W/m proximate to a portion of the heater.

The AC or modulated DC resistance and/or the heat output of the temperature limited heater may decrease sharply above the Curie temperature due to the Curie effect. In certain embodiments, the value of the electrical resistance or heat output above or near the Curie temperature is at most one-half of the value of electrical resistance or heat output at a certain point below the Curie temperature. In some embodiments, the heat output above or near the Curie temperature is at most 40%, 30%, 20% or less, down to 0% of the heat output at a certain point below the Curie temperature (for example, 30 °C below the Curie temperature, 40 °C below the Curie temperature, 50 °C below the Curie temperature, or 100 °C below the Curie temperature). In certain embodiments, the electrical resistance above or near the Curie temperature decreases to 80%, 70%, 60%, 50%, or less to 0% of the electrical resistance at a certain point below the Curie temperature (for example, 30 °C below the Curie temperature, 40 °C below the Curie temperature, 50 °C below the Curie temperature, or 100 °C below the Curie temperature).

In some embodiments, AC frequency is adjusted to change the skin depth of the ferromagnetic material. For example, the skin depth of 1% carbon steel at room temperature is 0.132 cm at 60 Hz, 0.0762 cm at 180 Hz, and 0.046 cm at 440 Hz. Since heater diameter is typically larger than twice the skin depth, using a higher frequency (and thus a heater with a smaller diameter) reduces heater costs. For a fixed geometry, the higher frequency results in a higher turndown ratio. The turndown ratio at a higher frequency is calculated by multiplying the turndown ratio at a lower frequency by the square root of the higher frequency divided by the square root of the lower frequency. In some embodiments, a frequency between 100 Hz and 1000 Hz, between

140 Hz and 200 Hz, or between 400 Hz and 600 Hz is used (for example, 180 Hz, 540 Hz, or 720 Hz). In some embodiments, high frequencies may be used. High frequencies may be, for example, at least 1000 Hz.

To maintain a substantially constant skin depth until the Curie temperature of the temperature limited heater is reached, the heater may be operated at a lower frequency when the heater is cold and operated at a higher frequency when the heater is hot. Line frequency heating is generally favorable, however, because there is less need for expensive components such as power supplies, transformers, or current modulators that alter frequency. Line frequency is the frequency of a general supply of current. Line frequency is typically 60 Hz, but may be 50 Hz or another frequency depending on the source for the supply of the current. Higher frequencies may be produced using commercially available equipment such as solid state variable frequency power supplies. Transformers that convert three-phase power to single-phase power with three times the frequency are commercially available. For example, high voltage three-phase power at 60 Hz may be transformed to single-phase power at 180 Hz and at a lower voltage. Such transformers are less expensive and more energy efficient than solid state variable frequency power supplies. In certain embodiments, transformers that convert three-phase power to single-phase power are used to increase the frequency of power supplied to the temperature limited heater.

In certain embodiments, modulated DC (for example, chopped DC, waveform modulated DC, or cycled DC) may be used to provide electrical power to the temperature limited heater. A DC modulator or DC chopper may be coupled to a DC power supply to provide an output of modulated direct current. In some embodiments, the DC power supply may include means for modulating DC. One example of a DC modulator is a DC-to-DC converter system. DC-to-DC converter systems are generally known in the art. DC is typically modulated or chopped into a desired waveform. Waveforms for DC modulation include, but are not limited to, square-wave, sinusoidal, deformed sinusoidal, deformed square-wave, triangular, and other regular or irregular waveforms.

The modulated DC waveform generally defines the frequency of the modulated DC. Thus, the modulated DC waveform may be selected to provide a desired modulated DC frequency. The shape and/or the rate of modulation (such as the rate of chopping) of the modulated DC waveform may be varied to vary the modulated DC frequency. DC may be modulated at frequencies that are higher than generally available AC frequencies. For example, modulated DC may be provided at frequencies of at least 1000 Hz. Increasing the frequency of supplied current to higher values advantageously increases the turndown ratio of the temperature limited heater.

In certain embodiments, the modulated DC waveform is adjusted or altered to vary the modulated DC frequency. The DC modulator may be able to adjust or alter the modulated DC waveform at any time during use of the temperature limited heater and at high currents or voltages. Thus, modulated DC provided to the temperature limited heater is not limited to a single frequency or even a small set of frequency values. Waveform selection using the DC modulator typically allows for a wide range of modulated DC frequencies and for discrete control of the modulated DC frequency. Thus, the modulated DC frequency is more easily set at a distinct value whereas AC frequency is generally limited to incremental values of the line frequency. Discrete control of the modulated DC frequency allows for more selective control over the turndown ratio of the temperature limited heater. Being able to selectively control the turndown ratio of the temperature limited

heater allows for a broader range of materials to be used in designing and constructing the temperature limited heater.

In certain embodiments, electrical power for the temperature limited heater is initially supplied using non-modulated DC or very low frequency modulated DC. Using non-modulated DC or very low frequency DC at earlier times of heating reduces losses associated with higher frequencies. Non-modulated DC and/or very low frequency modulated DC is also cheaper to use during initial heating times. After a selected temperature is reached in a temperature limited heater; modulated DC, higher frequency modulated DC, or AC is used to provide electrical power to the temperature limited heater so that the heat output will decrease near, at, or above the Curie temperature.

In some embodiments, the modulated DC frequency or the AC frequency is adjusted to compensate for changes in properties (for example, subsurface conditions such as temperature or pressure) of the temperature limited heater during use. The modulated DC frequency or the AC frequency provided to the temperature limited heater is varied based on assessed downhole conditions. For example, as the temperature of the temperature limited heater in the wellbore increases, it may be advantageous to increase the frequency of the current provided to the heater, thus increasing the turndown ratio of the heater. In an embodiment, the downhole temperature of the temperature limited heater in the wellbore is assessed.

In certain embodiments, the modulated DC frequency, or the AC frequency, is varied to adjust the turndown ratio of the temperature limited heater. The turndown ratio may be adjusted to compensate for hot spots occurring along a length of the temperature limited heater. For example, the turndown ratio is increased because the temperature limited heater is getting too hot in certain locations. In some embodiments, the modulated DC frequency, or the AC frequency, are varied to adjust a turndown ratio without assessing a subsurface condition.

At or near the Curie temperature of the ferromagnetic material, a relatively small change in voltage may cause a relatively large change in current load. The relatively small change in voltage may produce problems in the power supplied to the temperature limited heater, especially at or near the Curie temperature. The problems include, but are not limited to, tripping a circuit breaker and/or blowing a fuse. In certain embodiments, an electrical current supply (for example, a supply of modulated DC or AC) provides a relatively constant amount of current that does not substantially vary with changes in load of the temperature limited heater. In an embodiment, the electrical current supply provides an amount of electrical current that remains within 15%, within 10%, within 5%, or within 2% of a selected constant current value when a load of the temperature limited heater changes.

Temperature limited heaters may generate an inductive load. The inductive load is due to some applied electrical current being used by the ferromagnetic material to generate a magnetic field in addition to generating a resistive heat output. As downhole temperature changes in the temperature limited heater, the inductive load of the heater changes due to changes in the magnetic properties of ferromagnetic materials in the heater with temperature. The inductive load of the temperature limited heater may cause a phase shift between the current and the voltage applied to the heater.

A reduction in actual power applied to the temperature limited heater may be caused by a time lag in the current waveform (for example, the current has a phase shift relative to the voltage due to an inductive load) and/or by distortions in the current waveform (for example, distortions in the current waveform caused by

introduced harmonics due to a non-linear load). Thus, it may take more current to apply a selected amount of power due to phase shifting or waveform distortion. The ratio of actual power applied and the apparent power that would have been transmitted if the same current were in phase and undistorted is the power factor. The power factor is always less than or equal to 1. The power factor is equal to 1 when there is no phase shift or distortion in the waveform.

Actual power applied to the temperature limited heater due to phase shift is described by EQN. 2:

$$(2) \quad P = I \times V \times \cos(\theta);$$

in which P is the actual power applied to the heater; I is the applied current; V is the applied voltage; and θ is the phase angle difference between voltage and current. If there is no distortion in the waveform, then $\cos(\theta)$ is equal to the power factor.

At higher frequencies (for example, modulated DC frequencies of at least 1000 Hz, 1500 Hz, or 2000 Hz), the problem with phase shifting and/or distortion is more pronounced. In certain embodiments, a capacitor is used to compensate for phase shifting caused by the inductive load. Capacitive load may be used to balance the inductive load because current for capacitance is 180 degrees out of phase from current for inductance. In some embodiments, a variable capacitor (for example, a solid state switching capacitor) is used to compensate for phase shifting caused by a varying inductive load. In an embodiment, the variable capacitor is placed at the wellhead for the temperature limited heater. Placing the variable capacitor at the wellhead allows the capacitance to be varied more easily in response to changes in the inductive load of the temperature limited heater. In certain embodiments, the variable capacitor is placed subsurface with the temperature limited heater, subsurface within the heater, or as close to the heating conductor as possible to minimize line losses due to the capacitor. In some embodiments, the variable capacitor is placed at a central location for a field of heater wells (in some embodiments, one variable capacitor may be used for several temperature limited heaters). In one embodiment, the variable capacitor is placed at the electrical junction between the field of heaters and the utility supply of electricity.

In certain embodiments, the variable capacitor is used to maintain the power factor of the temperature limited heater or the power factor of the electrical conductors in the temperature limited heater above a selected value. In some embodiments, the variable capacitor is used to maintain the power factor of the temperature limited heater above the selected value of 0.85, 0.9, or 0.95. In certain embodiments, the capacitance in the variable capacitor is varied to maintain the power factor of the temperature limited heater above the selected value.

In some embodiments, the modulated DC waveform is pre-shaped to compensate for phase shifting and/or harmonic distortion. The waveform may be pre-shaped by modulating the waveform into a specific shape. For example, the DC modulator is programmed or designed to output a waveform of a particular shape. In certain embodiments, the pre-shaped waveform is varied to compensate for changes in the inductive load of the temperature limited heater caused by changes in the phase shift and/or the harmonic distortion. In certain embodiments, heater conditions (for example, downhole temperature or pressure) are assessed and used to determine the pre-shaped waveform. In some embodiments, the pre-shaped waveform is determined through the use of a simulation or calculations based on the heater design. Simulations and/or heater conditions may also be used to determine the capacitance needed for the variable capacitor.

In some embodiments, the modulated DC waveform modulates DC between 100% (full current load) and 0% (no current load). For example, a square-wave may modulate 100 A DC between 100% (100 A) and 0% (0 A) (full wave modulation), between 100% (100 A) and 50% (50 A), or between 75% (75 A) and 25% (25 A). The lower current load (for example, the 0%, 25%, or 50% current load) may be defined as the base
5 current load.

In some embodiments, electrical voltage and/or electrical current is adjusted to change the skin depth of the ferromagnetic material. Increasing the voltage and/or decreasing the current may decrease the skin depth of the ferromagnetic material. A smaller skin depth allows a temperature limited heater with a smaller diameter to be used, thereby reducing equipment costs. In certain embodiments, the applied current is at least 1 amp (A), 10
10 A, 70 A, 100 A, 200 A, 500 A, or greater, up to 2000 A. In some embodiments, alternating current is supplied at voltages above 200 volts, above 480 volts, above 650 volts, above 1000 volts, above 1500 volts, or higher, up to 10000 volts.

In an embodiment, the temperature limited heater includes an inner conductor inside an outer conductor. The inner conductor and the outer conductor are radially disposed about a central axis. The inner
15 and outer conductors may be separated by an insulation layer. In certain embodiments, the inner and outer conductors are coupled at the bottom of the temperature limited heater. Electrical current may flow into the temperature limited heater through the inner conductor and return through the outer conductor. One or both conductors may include ferromagnetic material.

The insulation layer may comprise an electrically insulating ceramic with high thermal conductivity,
20 such as magnesium oxide, aluminum oxide, silicon dioxide, beryllium oxide, boron nitride, silicon nitride, or combinations thereof. The insulating layer may be a compacted powder (for example, compacted ceramic powder). Compaction may improve thermal conductivity and provide better insulation resistance. For lower temperature applications, polymer insulation made from, for example, fluoropolymers, polyimides, polyamides, and/or polyethylenes, may be used. In some embodiments, the polymer insulation is made of perfluoroalkoxy
25 (PFA) or polyetheretherketone (PEEK™ (Victrex Ltd, England)). The insulating layer may be chosen to be substantially infrared transparent to aid heat transfer from the inner conductor to the outer conductor. In an embodiment, the insulating layer is transparent quartz sand. The insulation layer may be air or a non-reactive gas such as helium, nitrogen, or sulfur hexafluoride. If the insulation layer is air or a non-reactive gas, there may be insulating spacers designed to inhibit electrical contact between the inner conductor and the outer
30 conductor. The insulating spacers may be made of, for example, high purity aluminum oxide or another thermally conducting, electrically insulating material such as silicon nitride. The insulating spacers may be a fibrous ceramic material such as Nextel™ 312 (3M Corporation, St. Paul, Minnesota), mica tape, or glass fiber. Ceramic material may be made of alumina, alumina-silicate, alumina-borosilicate, silicon nitride, boron nitride, or other materials.

The insulation layer may be flexible and/or substantially deformation tolerant. For example, if the
35 insulation layer is a solid or compacted material that substantially fills the space between the inner and outer conductors, the temperature limited heater may be flexible and/or substantially deformation tolerant. Forces on the outer conductor can be transmitted through the insulation layer to the solid inner conductor, which may resist crushing. Such a temperature limited heater may be bent, dog-legged, and spiraled without causing the

outer conductor and the inner conductor to electrically short to each other. Deformation tolerance may be important if the wellbore is likely to undergo substantial deformation during heating of the formation.

In certain embodiments, the outer conductor is chosen for corrosion and/or creep resistance. In one embodiment, austenitic (non-ferromagnetic) stainless steels such as 304H, 347H, 347HH, 316H, 310H, 347HP, 5 NF709 (Nippon Steel Corp., Japan) stainless steels, or combinations thereof may be used in the outer conductor. The outer conductor may also include a clad conductor. For example, a corrosion resistant alloy such as 800H or 347H stainless steel may be clad for corrosion protection over a ferromagnetic carbon steel tubular. If high temperature strength is not required, the outer conductor may be constructed from the ferromagnetic metal with good corrosion resistance such as one of the ferritic stainless steels. In one embodiment, a ferritic alloy of 10 82.3% by weight iron with 17.7% by weight chromium (Curie temperature of 678 °C) provides desired corrosion resistance.

The Metals Handbook, vol. 8, page 291 (American Society of Materials (ASM)) includes a graph of Curie temperature of iron-chromium alloys versus the amount of chromium in the alloys. In some temperature limited heater embodiments, a separate support rod or tubular (made from 347H stainless steel) is coupled to the 15 temperature limited heater made from an iron-chromium alloy to provide strength and/or creep resistance. The support material and/or the ferromagnetic material may be selected to provide a 100,000 hour creep-rupture strength of at least 20.7 MPa at 650 °C. In some embodiments, the 100,000 hour creep-rupture strength is at least 13.8 MPa at 650 °C or at least 6.9 MPa at 650 °C. For example, 347H steel has a favorable creep-rupture strength at or above 650°C. In some embodiments, the 100,000 hour creep-rupture strength ranges from 6.9 20 MPa to 41.3 MPa or more for longer heaters and/or higher earth or fluid stresses. In embodiments with the inner ferromagnetic conductor and the outer ferromagnetic conductor, the skin effect current path occurs on the outside of the inner conductor and on the inside of the outer conductor. Thus, the outside of the outer conductor may be clad with the corrosion resistant alloy, such as stainless steel, without affecting the skin effect current path on the inside of the outer conductor.

25 In embodiments with the inner ferromagnetic conductor and the outer ferromagnetic conductor, the skin effect current path occurs on the outside of the inner conductor and on the inside of the outer conductor. Thus, the outside of the outer conductor may be clad with the corrosion resistant alloy, such as stainless steel, without affecting the skin effect current path on the inside of the outer conductor.

A ferromagnetic conductor with a thickness of at least the skin depth at the Curie temperature allows a 30 substantial decrease in AC resistance of the ferromagnetic material as the skin depth increases sharply near the Curie temperature. In certain embodiments when the ferromagnetic conductor is not clad with a highly conducting material such as copper, the thickness of the conductor may be 1.5 times the skin depth near the Curie temperature, 3 times the skin depth near the Curie temperature, or even 10 or more times the skin depth near the Curie temperature. If the ferromagnetic conductor is clad with copper, thickness of the ferromagnetic 35 conductor may be substantially the same as the skin depth near the Curie temperature. In some embodiments, the ferromagnetic conductor clad with copper has a thickness of at least three-fourths of the skin depth near the Curie temperature.

In certain embodiments, the temperature limited heater includes a composite conductor with a ferromagnetic tubular and a non-ferromagnetic, high electrical conductivity core. The non-ferromagnetic, high 40 electrical conductivity core reduces a required diameter of the conductor. For example, the conductor may be a

composite 1.19 cm diameter conductor with a core of 0.575 cm diameter copper clad with a 0.298 cm thickness of ferritic stainless steel or carbon steel surrounding the core. A composite conductor allows the electrical resistance of the temperature limited heater to decrease more steeply near the Curie temperature. As the skin depth increases near the Curie temperature to include the copper core, the electrical resistance decreases very sharply.

The composite conductor may increase the conductivity of the temperature limited heater and/or allow the heater to operate at lower voltages. In an embodiment, the composite conductor exhibits a relatively flat resistance versus temperature profile. In some embodiments, the temperature limited heater exhibits a relatively flat resistance versus temperature profile between 100 °C and 750 °C or between 300 °C and 600 °C. The relatively flat resistance versus temperature profile may also be exhibited in other temperature ranges by adjusting, for example, materials and/or the configuration of materials in the temperature limited heater. In certain embodiments, the relative thickness of each material in the composite conductor is selected to produce a desired resistivity versus temperature profile for the temperature limited heater.

FIGS. 8-32 depict various embodiments of temperature limited heaters. One or more features of an embodiment of the temperature limited heater depicted in any of these figures may be combined with one or more features of other embodiments of temperature limited heaters depicted in these figures. In certain embodiments described herein, temperature limited heaters are dimensioned to operate at a frequency of 60 Hz AC. It is to be understood that dimensions of the temperature limited heater may be adjusted from those described herein in order for the temperature limited heater to operate in a similar manner at other AC frequencies or with modulated DC.

FIG. 8 depicts a cross-sectional representation of an embodiment of the temperature limited heater with an outer conductor having a ferromagnetic section and a non-ferromagnetic section. FIGS. 9 and 10 depict transverse cross-sectional views of the embodiment shown in FIG. 8. In one embodiment, ferromagnetic section 132 is used to provide heat to hydrocarbon layers in the formation. Non-ferromagnetic section 134 is used in the overburden of the formation. Non-ferromagnetic section 134 provides little or no heat to the overburden, thus inhibiting heat losses in the overburden and improving heater efficiency. Ferromagnetic section 132 includes a ferromagnetic material such as 409 stainless steel or 410 stainless steel. 409 stainless steel is readily available as strip material. Ferromagnetic section 132 has a thickness of 0.3 cm. Non-ferromagnetic section 134 is copper with a thickness of 0.3 cm. Inner conductor 156 is copper. Inner conductor 156 has a diameter of 0.9 cm. Electrical insulator 158 is silicon nitride, boron nitride, magnesium oxide powder, or another suitable insulator material. Electrical insulator 158 has a thickness of 0.1 cm to 0.3 cm.

FIG. 11 depicts a cross-sectional representation of an embodiment of a temperature limited heater with an outer conductor having a ferromagnetic section and a non-ferromagnetic section placed inside a sheath.

FIGS. 12, 13, and 14 depict transverse cross-sectional views of the embodiment shown in FIG. 11.

Ferromagnetic section 132 is 410 stainless steel with a thickness of 0.6 cm. Non-ferromagnetic section 134 is copper with a thickness of 0.6 cm. Inner conductor 156 is copper with a diameter of 0.9 cm. Outer conductor 160 includes ferromagnetic material. Outer conductor 160 provides some heat in the overburden section of the heater. Providing some heat in the overburden inhibits condensation or refluxing of fluids in the overburden. Outer conductor 160 is 409, 410, or 446 stainless steel with an outer diameter of 3.0 cm and a thickness of 0.6 cm. Electrical insulator 158 is magnesium oxide powder with a thickness of 0.3 cm. In some embodiments,

electrical insulator 158 is silicon nitride, boron nitride, or hexagonal type boron nitride. Conductive section 162 may couple inner conductor 156 with ferromagnetic section 132 and/or outer conductor 160.

FIG. 15 depicts a cross-sectional representation of an embodiment of a temperature limited heater with a ferromagnetic outer conductor. The heater is placed in a corrosion resistant jacket. A conductive layer is placed between the outer conductor and the jacket. FIGS. 16 and 17 depict transverse cross-sectional views of the embodiment shown in FIG. 15. Outer conductor 160 is a ¾" Schedule 80 446 stainless steel pipe. In an embodiment, conductive layer 164 is placed between outer conductor 160 and jacket 166. Conductive layer 164 is a copper layer. Outer conductor 160 is clad with conductive layer 164. In certain embodiments, conductive layer 164 includes one or more segments (for example, conductive layer 164 includes one or more copper tube segments). Jacket 166 is a 1-¼" Schedule 80 347H stainless steel pipe or a 1-½" Schedule 160 347H stainless steel pipe. In an embodiment, inner conductor 156 is 4/0 MGT-1000 furnace cable with stranded nickel-coated copper wire with layers of mica tape and glass fiber insulation. 4/0 MGT-1000 furnace cable is UL type 5107 (available from Allied Wire and Cable (Phoenixville, Pennsylvania)). Conductive section 162 couples inner conductor 156 and jacket 166. In an embodiment, conductive section 162 is copper.

FIG. 18 depicts a cross-sectional representation of an embodiment of a temperature limited heater with an outer conductor. The outer conductor includes a ferromagnetic section and a non-ferromagnetic section. The heater is placed in a corrosion resistant jacket. A conductive layer is placed between the outer conductor and the jacket. FIGS. 19 and 20 depict transverse cross-sectional views of the embodiment shown in FIG. 18. Ferromagnetic section 132 is 409, 410, or 446 stainless steel with a thickness of 0.9 cm. Non-ferromagnetic section 134 is copper with a thickness of 0.9 cm. Ferromagnetic section 132 and non-ferromagnetic section 134 are placed in jacket 166. Jacket 166 is 304 stainless steel with a thickness of 0.1 cm. Conductive layer 164 is a copper layer. Electrical insulator 158 is silicon nitride, boron nitride, or magnesium oxide with a thickness of 0.1 to 0.3 cm. Inner conductor 156 is copper with a diameter of 1.0 cm.

In an embodiment, ferromagnetic section 132 is 446 stainless steel with a thickness of 0.9 cm. Jacket 166 is 410 stainless steel with a thickness of 0.6 cm. 410 stainless steel has a higher Curie temperature than 446 stainless steel. Such a temperature limited heater may "contain" current such that the current does not easily flow from the heater to the surrounding formation and/or to any surrounding water (for example, brine, groundwater, or formation water). In this embodiment, current flows through ferromagnetic section 132 until the Curie temperature of the ferromagnetic section is reached. After the Curie temperature of ferromagnetic section 132 is reached, current flows through conductive layer 164. The ferromagnetic properties of jacket 166 (410 stainless steel) inhibit the current from flowing outside the jacket and "contain" the current. Jacket 166 may also have a thickness that provides strength to the temperature limited heater.

FIG. 21 depicts a cross-sectional representation of an embodiment of a temperature limited heater. The heating section of the temperature limited heater includes non-ferromagnetic inner conductors and a ferromagnetic outer conductor. The overburden section of the temperature limited heater includes a non-ferromagnetic outer conductor. FIGS. 22, 23, and 24 depict transverse cross-sectional views of the embodiment shown in FIG. 21. Inner conductor 156 is copper with a diameter of 1.0 cm. Electrical insulator 158 is placed between inner conductor 156 and conductive layer 164. Electrical insulator 158 is silicon nitride, boron nitride, or magnesium oxide with a thickness of 0.1 cm to 0.3 cm. Conductive layer 164 is copper with a thickness of

0.1 cm. Insulation layer 168 is in the annulus outside of conductive layer 164. The thickness of the annulus may be 0.3 cm. Insulation layer 168 is quartz sand.

Heating section 170 may provide heat to one or more hydrocarbon layers in the formation. Heating section 170 includes ferromagnetic material such as 409 stainless steel or 410 stainless steel. Heating section 170 has a thickness of 0.9 cm. Endcap 172 is coupled to an end of heating section 170. Endcap 172 electrically couples heating section 170 to inner conductor 156 and/or conductive layer 164. Endcap 172 is 304 stainless steel. Heating section 170 is coupled to overburden section 174. Overburden section 174 includes carbon steel and/or other suitable support materials. Overburden section 174 has a thickness of 0.6 cm. Overburden section 174 is lined with conductive layer 176. Conductive layer 176 is copper with a thickness of 0.3 cm.

FIG. 25 depicts a cross-sectional representation of an embodiment of a temperature limited heater with an overburden section and a heating section. FIGS. 26 and 27 depict transverse cross-sectional views of the embodiment shown in FIG. 25. The overburden section includes portion 156A of inner conductor 156. Portion 156A is copper with a diameter of 1.3 cm. The heating section includes portion 156B of inner conductor 156. Portion 156B is copper with a diameter of 0.5 cm. Portion 156B is placed in ferromagnetic conductor 178. Ferromagnetic conductor 178 is 446 stainless steel with a thickness of 0.4 cm. Electrical insulator 158 is silicon nitride, boron nitride, or magnesium oxide with a thickness of 0.2 cm. Outer conductor 160 is copper with a thickness of 0.1 cm. Outer conductor 160 is placed in jacket 166. Jacket 166 is 316H or 347H stainless steel with a thickness of 0.2 cm.

FIG. 28A and FIG. 28B depict cross-sectional representations of an embodiment of a temperature limited heater with a ferromagnetic inner conductor. Inner conductor 156 is a 1" Schedule XXS 446 stainless steel pipe. In some embodiments, inner conductor 156 includes 409 stainless steel, 410 stainless steel, Invar 36, Alloy 42-6, Alloy 52, or other ferromagnetic materials. Alloy 42-6 is 42.5% by weight nickel, 5.75% by weight chromium, and the remainder iron. Alloy 42-6 has a Curie temperature of 295 °C. Alloy 52 is 50.5% by weight nickel, 0.10% by weight silicon, 0.30% by weight manganese, and the remainder iron. Alloy 52 has a Curie temperature of 482 °C. Inner conductor 156 has a diameter of 2.5 cm. Electrical insulator 158 is silicon nitride, boron nitride, magnesium oxide, polymers, Nextel ceramic fiber, mica, or glass fibers. Outer conductor 160 is copper or any other non-ferromagnetic material such as aluminum. Outer conductor 160 is coupled to jacket 166. Jacket 166 is 304H, 316H, or 347H stainless steel. In this embodiment, a majority of the heat is produced in inner conductor 156.

FIG. 29A and FIG. 29B depict cross-sectional representations of an embodiment of a temperature limited heater with a ferromagnetic inner conductor and a non-ferromagnetic core. Inner conductor 156 includes 446 stainless steel, 409 stainless steel, 410 stainless steel, Invar 36, Alloy 42-6, Alloy 52, or other ferromagnetic materials. Core 180 is tightly bonded inside inner conductor 156. Core 180 is a rod of copper or other non-ferromagnetic material. Core 180 is inserted as a tight fit inside inner conductor 156 before a drawing operation. In some embodiments, core 180 and inner conductor 156 are coextrusion bonded. Outer conductor 160 is 347H stainless steel. A drawing or rolling operation to compact electrical insulator 158 may ensure good electrical contact between inner conductor 156 and core 180. In this embodiment, heat is produced primarily in inner conductor 156 until the Curie temperature is approached. Resistance then decreases sharply as alternating current penetrates core 180.

FIG. 30A and FIG. 30B depict cross-sectional representations of an embodiment of a temperature limited heater with a ferromagnetic outer conductor. Inner conductor 156 is nickel-clad copper. Electrical insulator 158 is silicon nitride, boron nitride, or magnesium oxide. Outer conductor 160 is a 1" Schedule XXS carbon steel pipe. In this embodiment, heat is produced primarily in outer conductor 160, resulting in a small temperature differential across electrical insulator 158.

FIG. 31A and FIG. 31B depict cross-sectional representations of an embodiment of a temperature limited heater with a ferromagnetic outer conductor that is clad with a corrosion resistant alloy. Inner conductor 156 is copper. Outer conductor 160 is a 1" Schedule XXS 446 stainless steel pipe. Outer conductor 160 is coupled to jacket 166. Jacket 166 is made of corrosion resistant material (for example, 347H stainless steel). Jacket 166 provides protection from corrosive fluids in the borehole (for example, sulfidizing and carburizing gases). Heat is produced primarily in outer conductor 160, resulting in a small temperature differential across electrical insulator 158.

FIG. 32A and FIG. 32B depict cross-sectional representations of an embodiment of a temperature limited heater with a ferromagnetic outer conductor. The outer conductor is clad with a conductive layer and a corrosion resistant alloy. Inner conductor 156 is copper. Electrical insulator 158 is silicon nitride, boron nitride, or magnesium oxide. Outer conductor 160 is a 1" Schedule 80 446 stainless steel pipe. Outer conductor 160 is coupled to jacket 166. Jacket 166 is made from corrosion resistant material. In an embodiment, conductive layer 164 is placed between outer conductor 160 and jacket 166. Conductive layer 164 is a copper layer. Heat is produced primarily in outer conductor 160, resulting in a small temperature differential across electrical insulator 158. Conductive layer 164 allows a sharp decrease in the resistance of outer conductor 160 as the outer conductor approaches the Curie temperature. Jacket 166 provides protection from corrosive fluids in the borehole.

In some embodiments, the conductor (for example, an inner conductor, an outer conductor, or a ferromagnetic conductor) is the composite conductor that includes two or more different materials. In certain embodiments, the composite conductor includes two or more ferromagnetic materials. In some embodiments, the composite ferromagnetic conductor includes two or more radially disposed materials. In certain embodiments, the composite conductor includes a ferromagnetic conductor and a non-ferromagnetic conductor. In some embodiments, the composite conductor includes the ferromagnetic conductor placed over a non-ferromagnetic core. Two or more materials may be used to obtain a relatively flat electrical resistivity versus temperature profile in a temperature region below the Curie temperature and/or a sharp decrease (a high turndown ratio) in the electrical resistivity at or near the Curie temperature. In some cases, two or more materials are used to provide more than one Curie temperature for the temperature limited heater.

The composite electrical conductor may be used as the conductor in any electrical heater embodiment described herein. For example, the composite conductor may be used as the conductor in a conductor-in-conduit heater or an insulated conductor heater. In certain embodiments, the composite conductor may be coupled to a support member such as a support conductor. The support member may be used to provide support to the composite conductor so that the composite conductor is not relied upon for strength at or near the Curie temperature. The support member may be useful for heaters of lengths of at least 100 m. The support member may be a non-ferromagnetic member that has good high temperature creep strength and good corrosion resistance. Examples of materials that are used for a support member include, but are not limited to, Haynes[®]

625 alloy and Haynes[®] HR120[®] alloy (Haynes International, Kokomo, IN), NF709, Incoloy[®] 800H alloy and 347HP alloy (Allegheny Ludlum Corp., Pittsburgh, PA). In some embodiments, materials in a composite conductor are directly coupled (for example, brazed, metallurgically bonded, or swaged) to each other and/or the support member. Using a support member may decouple the ferromagnetic member from having to provide support for the temperature limited heater, especially at or near the Curie temperature. Thus, the temperature limited heater may be designed with more flexibility in the selection of ferromagnetic materials.

FIG. 33 depicts a cross-sectional representation of an embodiment of the composite conductor with the support member. Core 180 is surrounded by ferromagnetic conductor 178 and support member 182. In some embodiments, core 180, ferromagnetic conductor 178, and support member 182 are directly coupled (for example, brazed together, metallurgically bonded together, or swaged together). In one embodiment, core 180 is copper, ferromagnetic conductor 178 is 446 stainless steel, and support member 182 is 347H alloy. In certain embodiments, support member 182 is a Schedule 80 pipe. Support member 182 surrounds the composite conductor having ferromagnetic conductor 178 and core 180. Ferromagnetic conductor 178 and core 180 are joined to form the composite conductor by, for example, a coextrusion process. For example, the composite conductor is a 1.9 cm outside diameter 446 stainless steel ferromagnetic conductor surrounding a 0.95 cm diameter copper core. This composite conductor inside a 1.9 cm Schedule 80 support member produces a turndown ratio of 1.7.

In certain embodiments, the diameter of core 180 is adjusted relative to a constant outside diameter of ferromagnetic conductor 178 to adjust the turndown ratio of the temperature limited heater. For example, the diameter of core 180 may be increased to 1.14 cm while maintaining the outside diameter of ferromagnetic conductor 178 at 1.9 cm to increase the turndown ratio of the heater to 2.2. In some embodiments, conductors (for example, core 180 and ferromagnetic conductor 178) in the composite conductor are separated by support member 182.

In some embodiments, the temperature limited heater is used to achieve lower temperature heating (for example, for heating fluids in a production well, heating a surface pipeline, or reducing the viscosity of fluids in a wellbore or near wellbore region). Varying the ferromagnetic materials of the temperature limited heater allows for lower temperature heating. In some embodiments, the ferromagnetic conductor is made of material with a lower Curie temperature than that of 446 stainless steel. For example, the ferromagnetic conductor may be an alloy of iron and nickel. The alloy may have between 30% by weight and 42% by weight nickel with the rest being iron. In one embodiment, the alloy is Invar 36. Invar 36 is 36% by weight nickel in iron and has a Curie temperature of 277 °C. In some embodiments, an alloy is a three component alloy with, for example, iron, chromium, and nickel. For example, an alloy may have 6% by weight chromium, 42% by weight nickel, and 52% by weight iron. A 2.5 cm diameter rod of Invar 36 has a turndown ratio of approximately 2 to 1 at the Curie temperature. Placing the Invar 36 alloy over a copper core may allow for a smaller rod diameter. A copper core may result in a high turndown ratio.

For temperature limited heaters that include a copper core or copper cladding, the copper may be protected with a relatively diffusion-resistant layer such as nickel. In some embodiments, the composite inner conductor includes iron clad over nickel clad over a copper core. The relatively diffusion-resistant layer inhibits migration of copper into other layers of the heater including, for example, an insulation layer. In some

embodiments, the relatively impermeable layer inhibits deposition of copper in a wellbore during installation of the heater into the wellbore.

For lower temperature applications, ferromagnetic conductor 178 in FIG. 34 is Alloy 42-6 coupled to conductor 184. Conductor 184 may be copper. In one embodiment, ferromagnetic conductor 178 is 1.9 cm
5 outside diameter Alloy 42-6 over copper conductor 184 with a 2:1 outside diameter to copper diameter ratio. In some embodiments, ferromagnetic conductor 178 includes other lower temperature ferromagnetic materials such as Alloy 32, Alloy 52, Invar 36, iron-nickel-chromium alloys, iron-nickel alloys, nickel-chromium alloys, or other nickel alloys. Conduit 186 may be a hollow sucker rod made from carbon steel. The carbon steel or other material used in conduit 186 confines alternating current or modulated direct current to the inside of the
10 conduit to inhibit stray voltages at the surface of the formation. Centralizer 188 may be made from gas pressure sintered reaction bonded silicon nitride. In some embodiments, centralizer 188 is made from polymers such as PFA or PEEKTM. In certain embodiments, polymer insulation is clad along an entire length of the heater. Conductor 184 and ferromagnetic conductor 178 are electrically coupled to conduit 186 with sliding connector 190.

FIG. 35 depicts an embodiment of a temperature limited heater with a low temperature ferromagnetic
15 outer conductor. Outer conductor 160 is glass sealing Alloy 42-6. Alloy 42-6 may be obtained from Carpenter Metals (Reading, Pennsylvania) or Anomet Products, Inc (Shrewsbury, Massachusetts). In some embodiments, outer conductor 160 includes other compositions and/or materials to get various Curie temperatures (for example, Carpenter Temperature Compensator "32" (Curie temperature of 199 °C; available from Carpenter
20 Metals) or Invar 36). In an embodiment, conductive layer 164 is coupled (for example, clad, welded, or brazed) to outer conductor 160. Conductive layer 164 is a copper layer. Conductive layer 164 improves a turndown ratio of outer conductor 160. Jacket 166 is a ferromagnetic metal such as carbon steel. Jacket 166 protects outer conductor 160 from a corrosive environment. Inner conductor 156 may have electrical insulator 158. Electrical insulator 158 may be a mica tape winding with overlaid fiberglass braid. In an embodiment, inner conductor
25 156 and electrical insulator 158 are a 4/0 MGT-1000 furnace cable or 3/0 MGT-1000 furnace cable. 4/0 MGT-1000 furnace cable or 3/0 MGT-1000 furnace cable is available from Allied Wire and Cable (Phoenixville, Pennsylvania). In some embodiments, a protective braid such as a stainless steel braid may be placed over electrical insulator 158.

Conductive section 162 electrically couples inner conductor 156 to outer conductor 160 and/or jacket
30 166. In some embodiments, jacket 166 touches or electrically contacts conductive layer 164 (for example, if the heater is placed in a horizontal configuration). If jacket 166 is a ferromagnetic metal such as carbon steel (with a Curie temperature above the Curie temperature of outer conductor 160), current will propagate only on the inside of the jacket. Thus, the outside of the jacket remains electrically safe during operation. In some embodiments, jacket 166 is drawn down (for example, swaged down in a die) onto conductive layer 164 so that
35 a tight fit is made between the jacket and the conductive layer. The heater may be spooled as coiled tubing for insertion into a wellbore. In other embodiments, an annular space is present between conductive layer 164 and jacket 166, as depicted in FIG. 35.

FIG. 36 depicts an embodiment of a temperature limited conductor-in-conduit heater. Conduit 186 is a
40 hollow sucker rod made of a ferromagnetic metal such as Alloy 42-6, Alloy 32, Alloy 52, Invar 36, iron-nickel-chromium alloys, iron-nickel alloys, nickel alloys, or nickel-chromium alloys. Inner conductor 156 has

electrical insulator 158. Electrical insulator 158 is a mica tape winding with overlaid fiberglass braid. In an embodiment, inner conductor 156 and electrical insulator 158 are a 4/0 MGT-1000 furnace cable or 3/0 MGT-1000 furnace cable. In some embodiments, polymer insulations are used for lower temperature Curie heaters. In certain embodiments, a protective braid is placed over electrical insulator 158. Conduit 186 has a wall
5 thickness that is greater than the skin depth at the Curie temperature (for example, 2 to 3 times the skin depth at the Curie temperature). In some embodiments, a more conductive conductor is coupled to conduit 186 to increase the turndown ratio of the heater.

FIG. 37 depicts a cross-sectional representation of an embodiment of a conductor-in-conduit temperature limited heater. Conductor 184 is coupled (for example, clad, coextruded, press fit, drawn inside) to
10 ferromagnetic conductor 178. A metallurgical bond between conductor 184 and ferromagnetic conductor 178 is favorable. Ferromagnetic conductor 178 is coupled to the outside of conductor 184 so that alternating current propagates through the skin depth of the ferromagnetic conductor at room temperature. Conductor 184 provides mechanical support for ferromagnetic conductor 178 at elevated temperatures. Ferromagnetic conductor 178 is
15 iron, an iron alloy (for example, iron with 10% to 27% by weight chromium for corrosion resistance), or any other ferromagnetic material. In one embodiment, conductor 184 is 304 stainless steel and ferromagnetic conductor 178 is 446 stainless steel. Conductor 184 and ferromagnetic conductor 178 are electrically coupled to conduit 186 with sliding connector 190. Conduit 186 may be a non-ferromagnetic material such as austenitic stainless steel.

FIG. 38 depicts a cross-sectional representation of an embodiment of a conductor-in-conduit temperature limited heater. Conduit 186 is coupled to ferromagnetic conductor 178 (for example, clad, press fit,
20 or drawn inside of the ferromagnetic conductor). Ferromagnetic conductor 178 is coupled to the inside of conduit 186 to allow alternating current to propagate through the skin depth of the ferromagnetic conductor at room temperature. Conduit 186 provides mechanical support for ferromagnetic conductor 178 at elevated temperatures. Conduit 186 and ferromagnetic conductor 178 are electrically coupled to conductor 184 with
25 sliding connector 190.

FIG. 39 depicts a cross-sectional representation of an embodiment of a conductor-in-conduit temperature limited heater with an insulated conductor. Insulated conductor 192 includes core 180, electrical
insulator 158, and jacket 166. Jacket 166 is made of a highly electrically conductive material such as copper. Core 180 is made of a lower temperature ferromagnetic material such as Alloy 42-6, Alloy 32, Invar 36,
30 iron-nickel-chromium alloys, iron-nickel alloys, nickel alloys, or nickel-chromium alloys. In certain embodiments, the materials of jacket 166 and core 180 are reversed so that the jacket is the ferromagnetic conductor and the core is the highly conductive portion of the heater. Ferromagnetic material used in jacket 166 or core 180 may have a thickness greater than the skin depth at the Curie temperature (for example, 2 to 3 times the skin depth at the Curie temperature). Endcap 172 is placed at an end of insulated conductor 192 to couple
35 core 180 to sliding connector 190. Endcap 172 is made of non-corrosive, electrically conducting materials such as nickel or stainless steel. In certain embodiments, conduit 186 is a hollow sucker rod made from, for example, carbon steel.

The temperature limited heater may be a single-phase heater or a three-phase heater. In a three-phase heater embodiment, the temperature limited heater has a delta or a wye configuration. Each of the three
40 ferromagnetic conductors in the three-phase heater may be inside a separate sheath. A connection between

conductors may be made at the bottom of the heater inside a splice section. The three conductors may remain insulated from the sheath inside the splice section.

In some three-phase heater embodiments, three ferromagnetic conductors are separated by insulation inside a common outer metal sheath. The three conductors may be insulated from the sheath or the three
5 conductors may be connected to the sheath at the bottom of the heater assembly. In another embodiment, a single outer sheath or three outer sheaths are ferromagnetic conductors and the inner conductors may be non-ferromagnetic (for example, aluminum, copper, or a highly conductive alloy). Alternatively, each of the three non-ferromagnetic conductors are inside a separate ferromagnetic sheath, and a connection between the
10 conductors is made at the bottom of the heater inside a splice section. The three conductors may remain insulated from the sheath inside the splice section.

In some embodiments, the three-phase heater includes three legs that are located in separate wellbores. The legs may be coupled at the bottom in a common contacting section (for example, a central wellbore, a connecting wellbore, or a solution filled contacting section).

In some embodiments, the temperature limited heater includes a single ferromagnetic conductor with
15 current returning through the formation. The heating element may be a ferromagnetic tubular (in an embodiment, 446 stainless steel (with 25% by weight chromium and a Curie temperature above 620 °C) clad over 304H, 316H, or 347H stainless steel) that extends through the heated target section and makes electrical contact to the formation in an electrical contacting section. The electrical contacting section may be located below a heated target section. For example, the electrical contacting section is in the underburden of the
20 formation. In an embodiment, the electrical contacting section is a section 60 m deep with a larger diameter than the heater wellbore. The tubular in the electrical contacting section is a high electrical conductivity metal. The annulus in the electrical contacting section may be filled with a contact material/solution such as brine or other materials that enhance electrical contact with the formation (for example, metal beads or hematite). The electrical contacting section may be located in a low resistivity brine saturated zone to maintain electrical
25 contact through the brine. In the electrical contacting section, the tubular diameter may also be increased to allow maximum current flow into the formation with lower heat dissipation in the fluid. Current may flow through the ferromagnetic tubular in the heated section and heat the tubular.

In an embodiment, three-phase temperature limited heaters are made with current connection through the formation. Each heater includes a single Curie temperature heating element with an electrical contacting
30 section in a brine saturated zone below a heated target section. In an embodiment, three such heaters are connected electrically at the surface in a three-phase wye configuration. The heaters may be deployed in a triangular pattern from the surface. In certain embodiments, the current returns through the earth to a neutral point between the three heaters. The three-phase Curie heaters may be replicated in a pattern that covers the entire formation.

35 A section of heater through a high thermal conductivity zone may be tailored to deliver more heat dissipation in the high thermal conductivity zone. Tailoring of the heater may be achieved by changing cross-sectional areas of the heating elements and/or using different metals in the heating elements. Thermal conductance of the insulation layer may also be modified in certain sections to control the thermal output to raise or lower the apparent Curie temperature zone.

In an embodiment, a temperature limited heater includes a hollow core or hollow inner conductor. Layers forming the heater may be perforated to allow fluids from the wellbore (for example, formation fluids or water) to enter the hollow core. Fluids in the hollow core may be transported (for example, pumped or gas lifted) to the surface through the hollow core. In some embodiments, a temperature limited heater with a hollow core or hollow inner conductor is used as a heater/production well or a production well. Fluids such as steam may be injected into the formation through the hollow inner conductor.

EXAMPLES

Non-restrictive examples of temperature limited heaters and properties of temperature limited heaters are set forth below.

FIG. 40 depicts data of electrical resistance (milliohms ($m\Omega$)) versus temperature ($^{\circ}C$) for a composite 0.75" diameter, 6 foot long Alloy 42-6 rod with a 0.375" diameter copper core at various applied electrical currents. Curves 194, 196, 198, 200, 202, 204, 206, and 208 depict resistance profiles as a function of temperature for the copper cored alloy 42-6 rod at 300 A AC (curve 194), 350 A AC (curve 196), 400 A AC (curve 198), 450 A AC (curve 200), 500 A AC (curve 202), 550 A AC (curve 204), 600 A AC (curve 206), and 10 A DC (curve 208). For the applied AC currents, the resistance decreased gradually with increasing temperature until the Curie temperature was reached. As the temperature approaches the Curie temperature, the resistance decreased more sharply. In contrast, the resistance showed a gradual increase with temperature for an applied DC current.

FIG. 41 depicts data of power output (watts per foot (W/ft)) versus temperature ($^{\circ}C$) for a composite 10.75" diameter, 6 foot long Alloy 42-6 rod with a 0.375" diameter copper core at various applied electrical currents. Curves 210, 212, 214, 216, 218, 220, 222, and 224 depict power as a function of temperature for the copper cored alloy 42-6 rod at 300 A AC (curve 210), 350 A AC (curve 212), 400 A AC (curve 214), 450 A AC (curve 216), 500 A AC (curve 218), 550 A AC (curve 220), 600 A AC (curve 222), and 10 A DC (curve 224). For the applied AC currents, the power output decreased gradually with increasing temperature until the Curie temperature was reached. As the temperature approaches the Curie temperature, the power output decreased more sharply. In contrast, the power output showed a relatively flat profile with temperature for an applied DC current.

FIG. 42 depicts data of electrical resistance (milliohms ($m\Omega$)) versus temperature ($^{\circ}C$) for a composite 0.75" diameter, 6 foot long Alloy 52 rod with a 0.375" diameter copper core at various applied electrical currents. Curves 226, 228, 230, 232, and 234 depict resistance profiles as a function of temperature for the copper cored Alloy 52 rod at 300 A AC (curve 226), 400 A AC (curve 228), 500 A AC (curve 230), 600 A AC (curve 232), and 10 A DC (curve 234). For the applied AC currents, the resistance increased gradually with increasing temperature until around 320 $^{\circ}C$. After 320 $^{\circ}C$, the resistance began to decrease gradually, decreasing more sharply as the temperature approached the Curie temperature. At the Curie temperature, the AC resistance decreased very sharply. In contrast, the resistance showed a gradual increase with temperature for an applied DC current. The turndown ratio for the 400 A applied AC current (curve GL102) was 2.8.

FIG. 43 depicts data of power output (watts per foot (W/ft)) versus temperature ($^{\circ}C$) for a composite 10.75" diameter, 6 foot long Alloy 52 rod with a 0.375" diameter copper core at various applied electrical currents. Curves 236, 238, 240, and 242 depict power as a function of temperature for the copper cored Alloy

52 rod at 300 A AC (curve 236), 400 A AC (curve 238), 500 A AC (curve 240), and 600 A AC (curve 242). For the applied AC currents, the power output increased gradually with increasing temperature until around 320 °C. After 320 °C, the power output began to decrease gradually, decreasing more sharply as the temperature approached the Curie temperature. At the Curie temperature, the power output decreased very sharply.

Further modifications and alternative embodiments of various aspects of the invention may be apparent to those skilled in the art in view of this description. Accordingly, this description is to be construed as illustrative only and is for the purpose of teaching those skilled in the art the general manner of carrying out the invention. It is to be understood that the forms of the invention shown and described herein are to be taken as the presently preferred embodiments. Elements and materials may be substituted for those illustrated and described herein, parts and processes may be reversed, and certain features of the invention may be utilized independently, all as would be apparent to one skilled in the art after having the benefit of this description of the invention. The scope of the claims should not be limited by the preferred embodiments set forth in the examples, but should be given the broadest interpretation consistent with the description as a whole.

CLAIMS:

1. A method for treating a hydrocarbon containing formation, comprising:
 - applying electrical current to one or more electrical conductors located in an opening in the formation to provide an electrically resistive heat output;
 - allowing the heat to transfer from the electrical conductors to a part of the formation containing hydrocarbons so that a viscosity of hydrocarbons in the part and at or near the opening in the formation is reduced;
 - providing gas at one or more locations in the opening to reduce the density of the hydrocarbons so that the hydrocarbons are lifted in the opening towards the surface of the formation by the formation pressure; and
 - producing the hydrocarbons through the opening,characterized in that at least one of the electrical conductors comprises an electrically resistive ferromagnetic material and provides a reduced amount of heat above or near a Curie temperature of the ferromagnetic material, and that the produced hydrocarbons have an API gravity of 20 degrees or less.
2. The method as claimed in claim 1, wherein the method further comprises placing the one or more electrical conductors in the opening.
3. The method as claimed in claims 1 or 2, wherein the viscosity of fluids at or near the opening is reduced to at most 0.05 Pa·s.
4. The method as claimed in any one of claims 1 to 3, wherein the method further comprises producing at least some fluids from the opening by pumping the fluids from the opening.
5. The method as claimed in any one of claims 1 to 4, wherein the gas comprises methane.
6. The method as claimed in any one of claims 1 to 5, wherein the method further comprises producing the fluids from the opening through a conduit located in the opening and/or providing the gas through one or more valves located along the conduit.
7. The method as claimed in any one of claims 1 to 6, wherein the method further comprises limiting a temperature in the formation at or near the opening to at most 250 °C.

8. The method as claimed in any one of claims 1 to 7, wherein the method further comprises applying AC or modulated DC to the one or more electrical conductors.

9. The method as claimed in any one of claims 1 to 8, wherein the method further comprises providing a reduced amount of heat above or near the selected temperature of at most 200 W/m of length of the electrical conductor and/or providing a heat output below the Curie temperature of at least 300 W/m of length of the electrical conductor.

10. The method as claimed in any one of claims 1 to 9, wherein the method further comprises providing a heat output from at least one of the electrical conductors, wherein an electrical resistance of such electrical conductors above or near the Curie temperature is 80% or less of the electrical resistance of such electrical conductors at 50 °C below the Curie temperature.

11. The method as claimed in any one of claims 1 to 10, wherein the hydrocarbon containing formation is a relatively permeable formation containing heavy hydrocarbons.

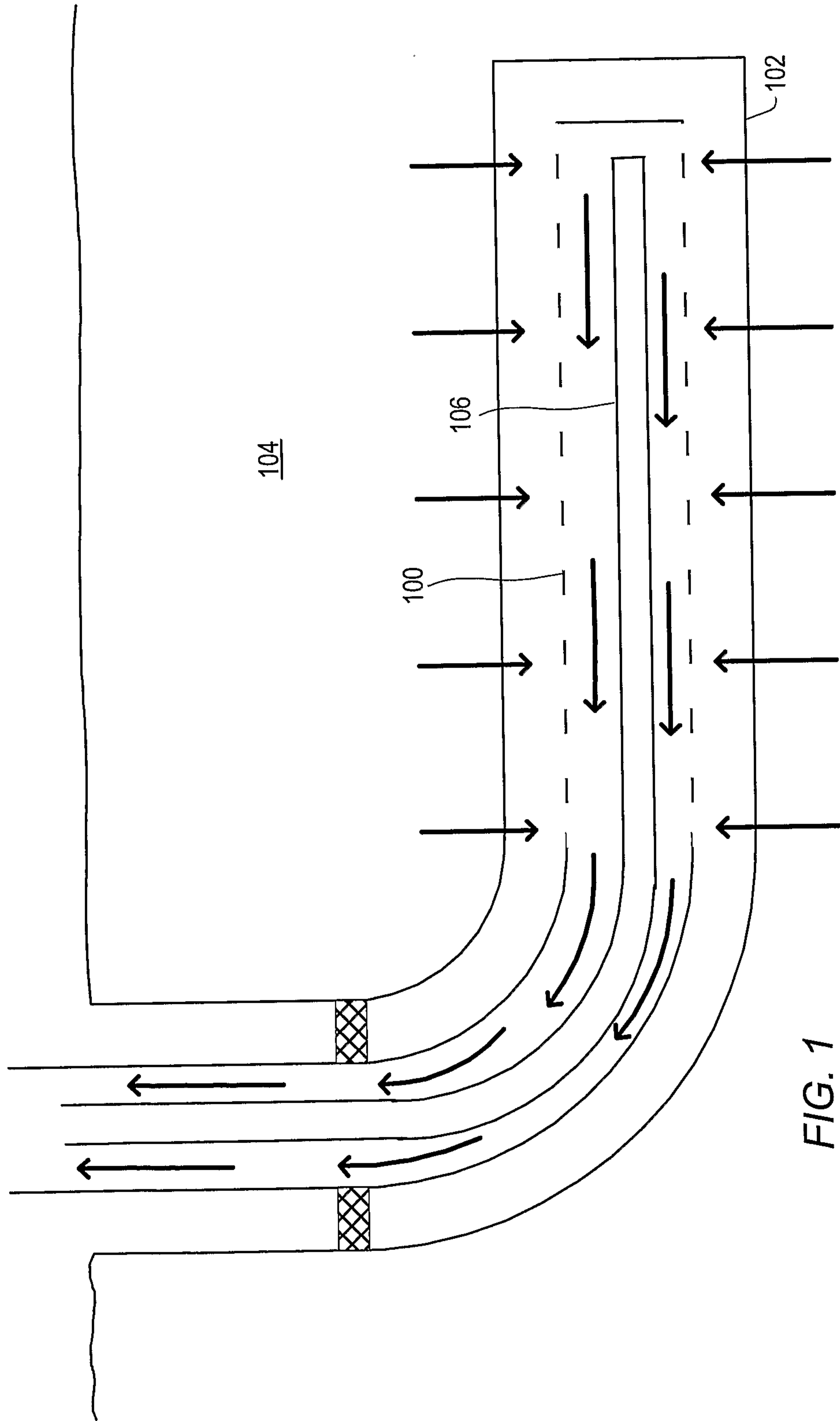

FIG. 1

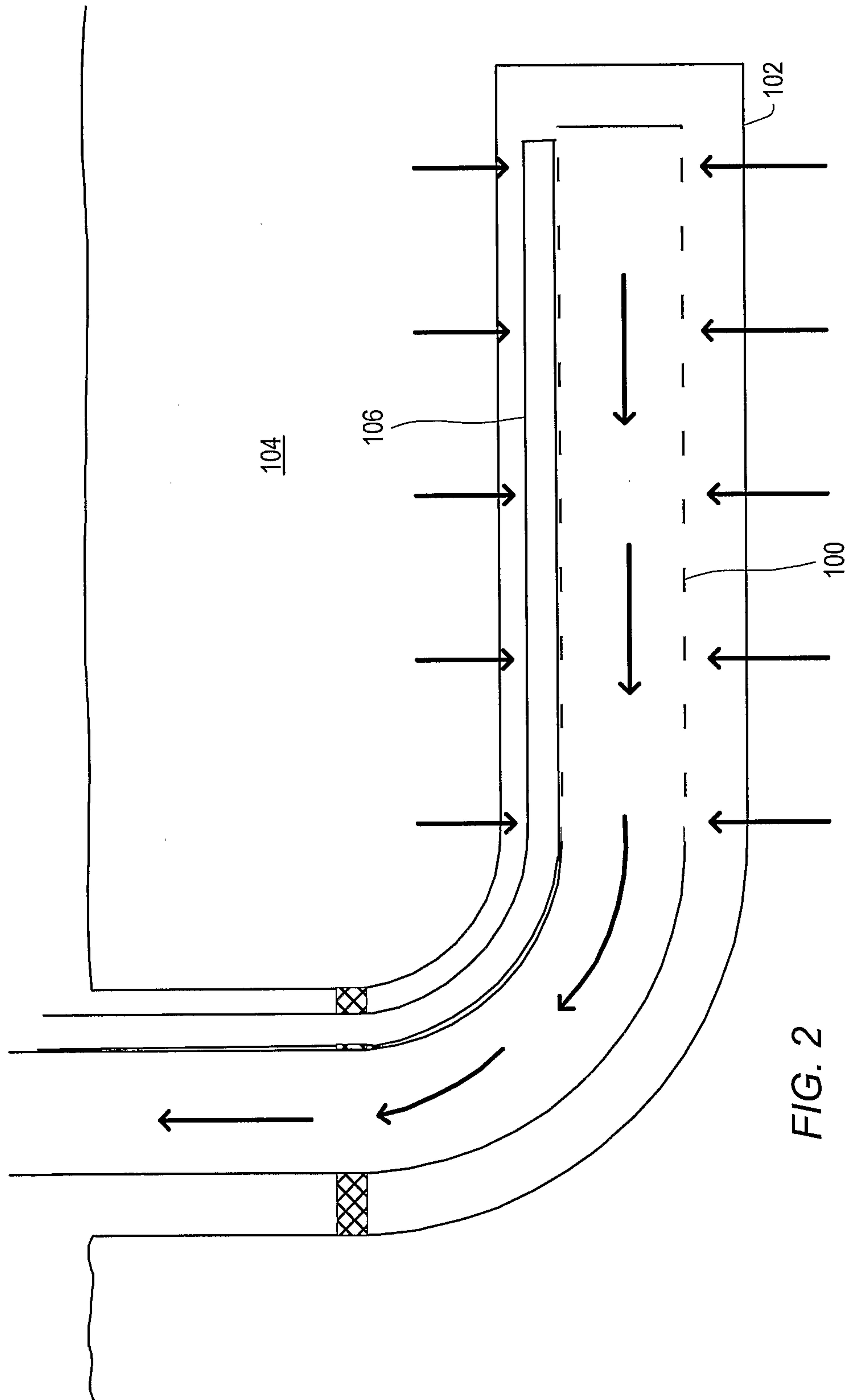

FIG. 2

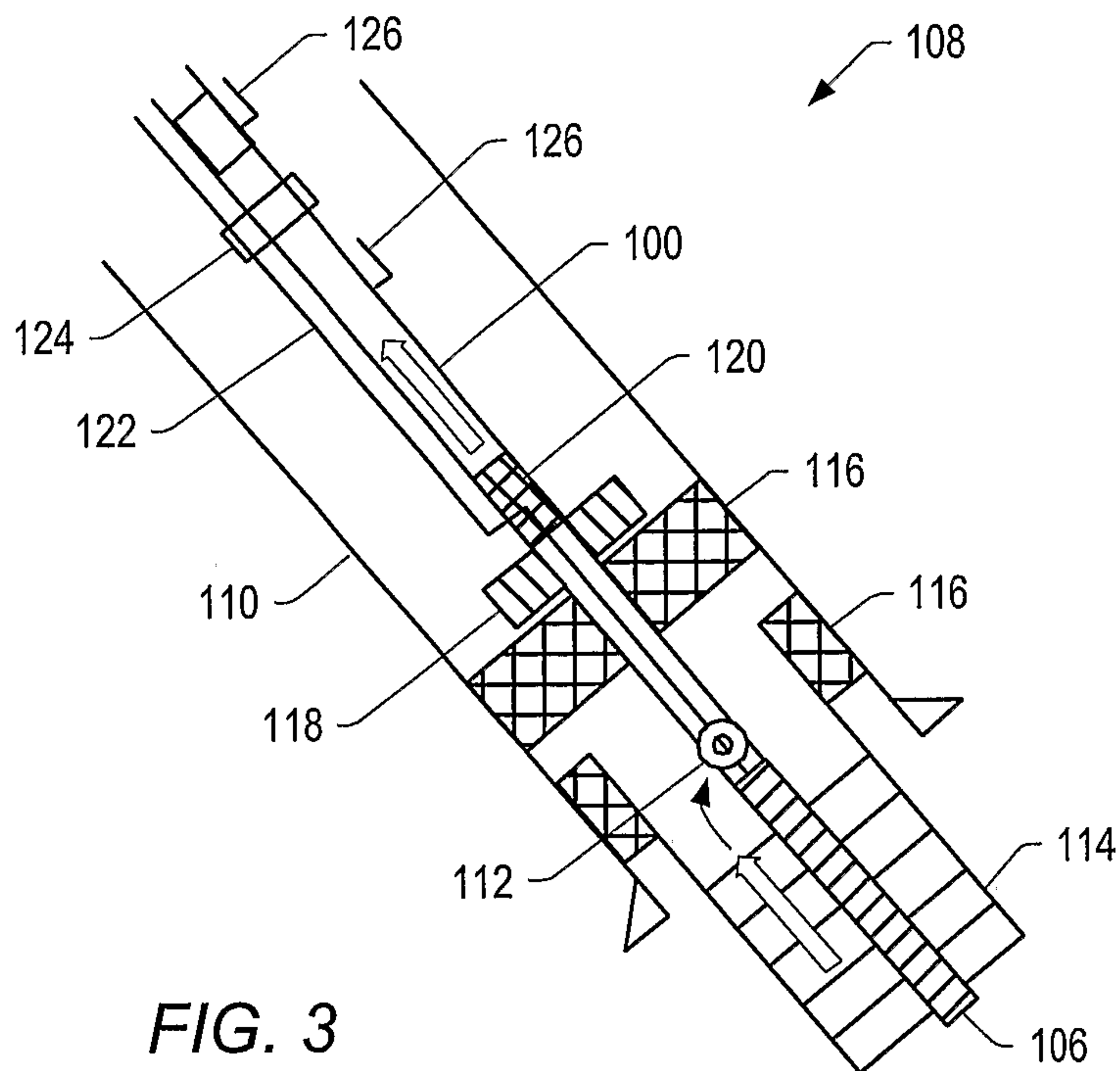

FIG. 3

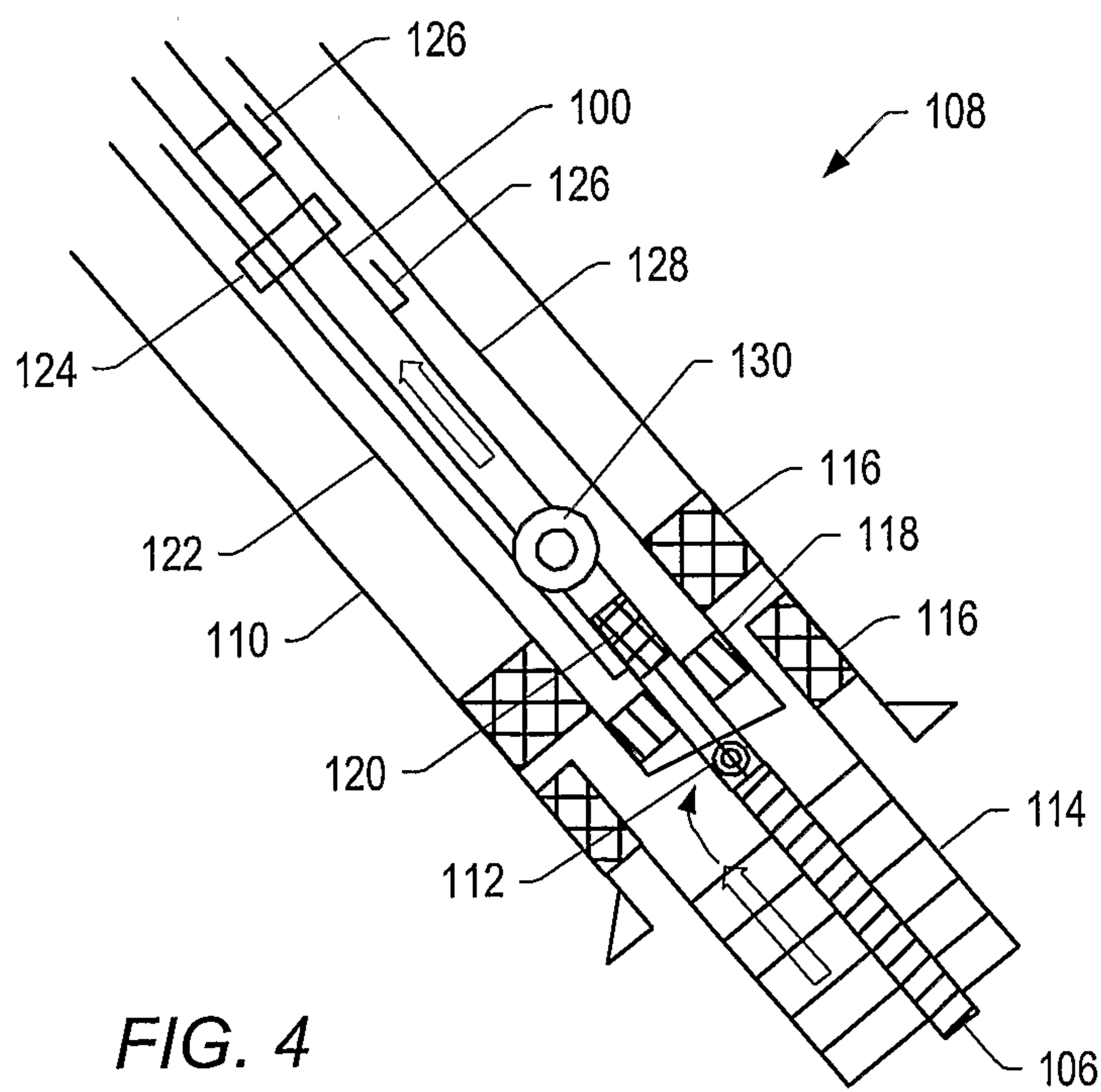

FIG. 4

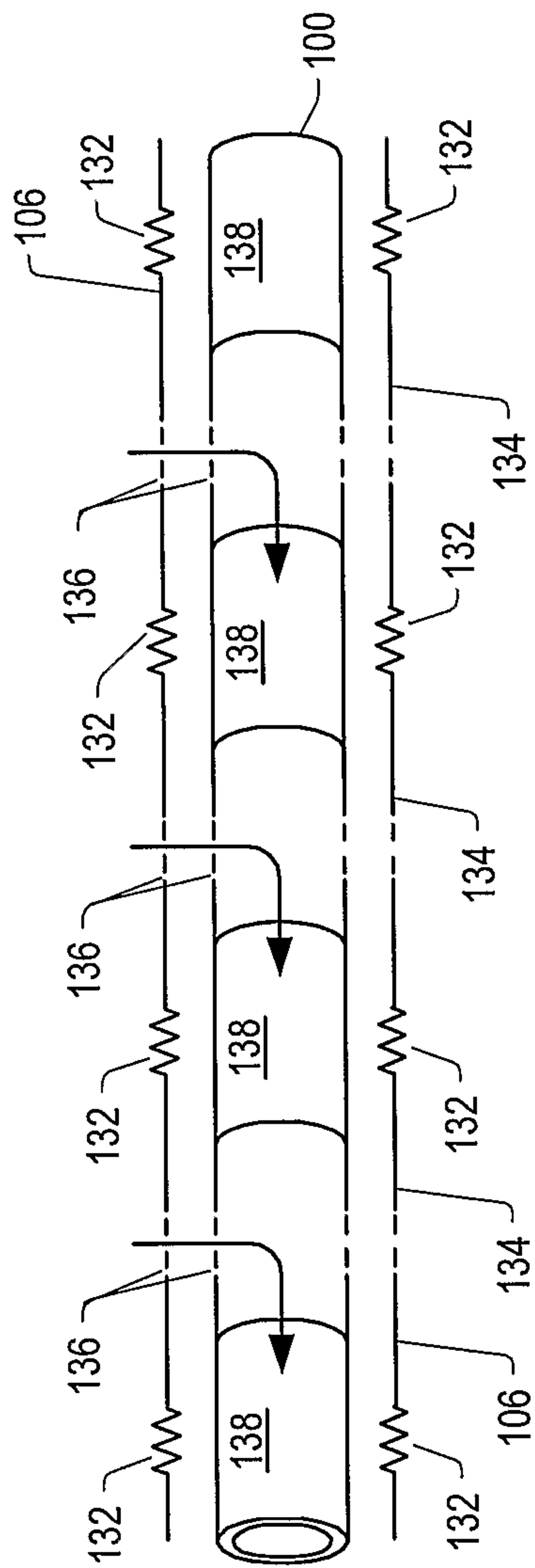

FIG. 5

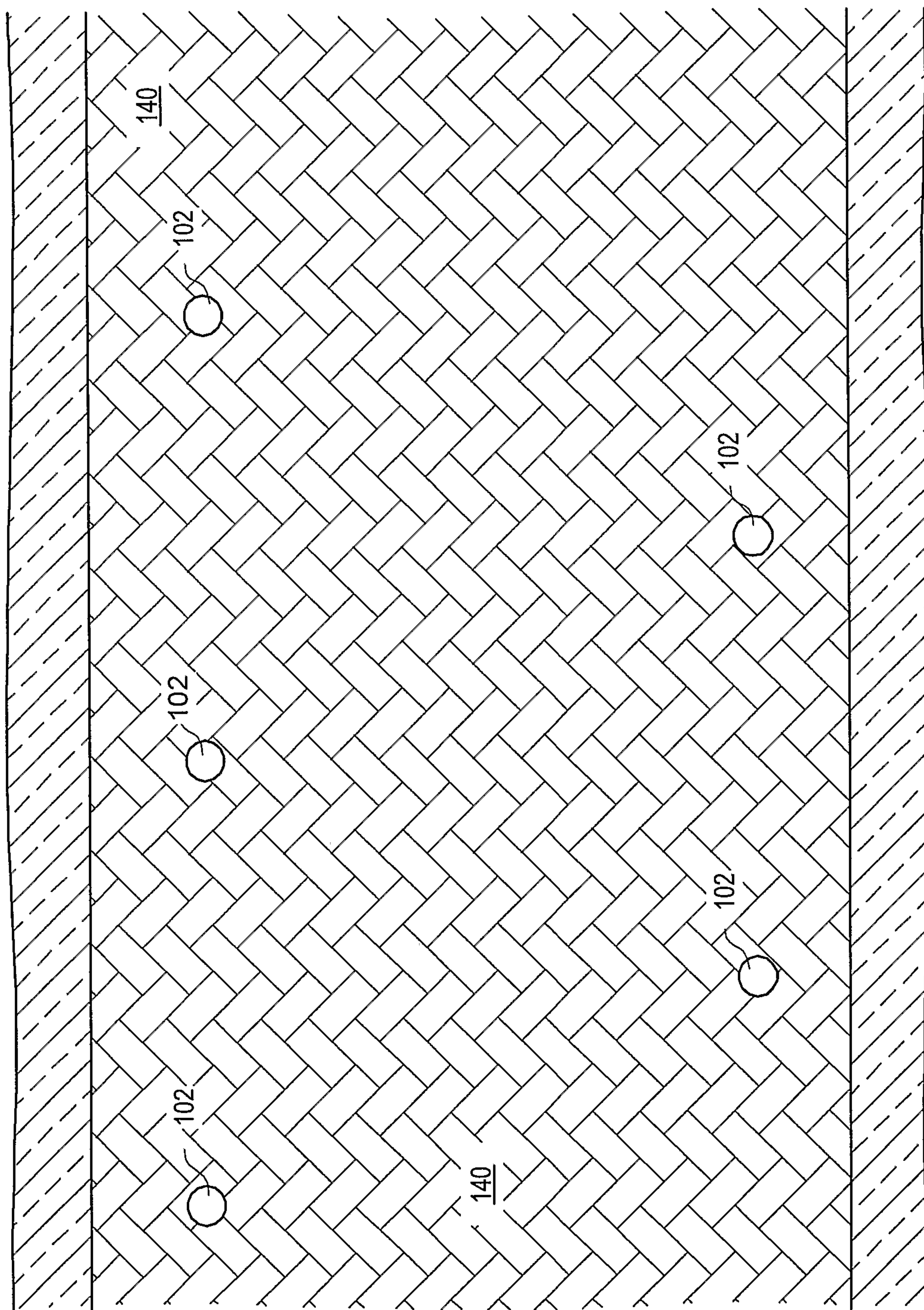

FIG. 6

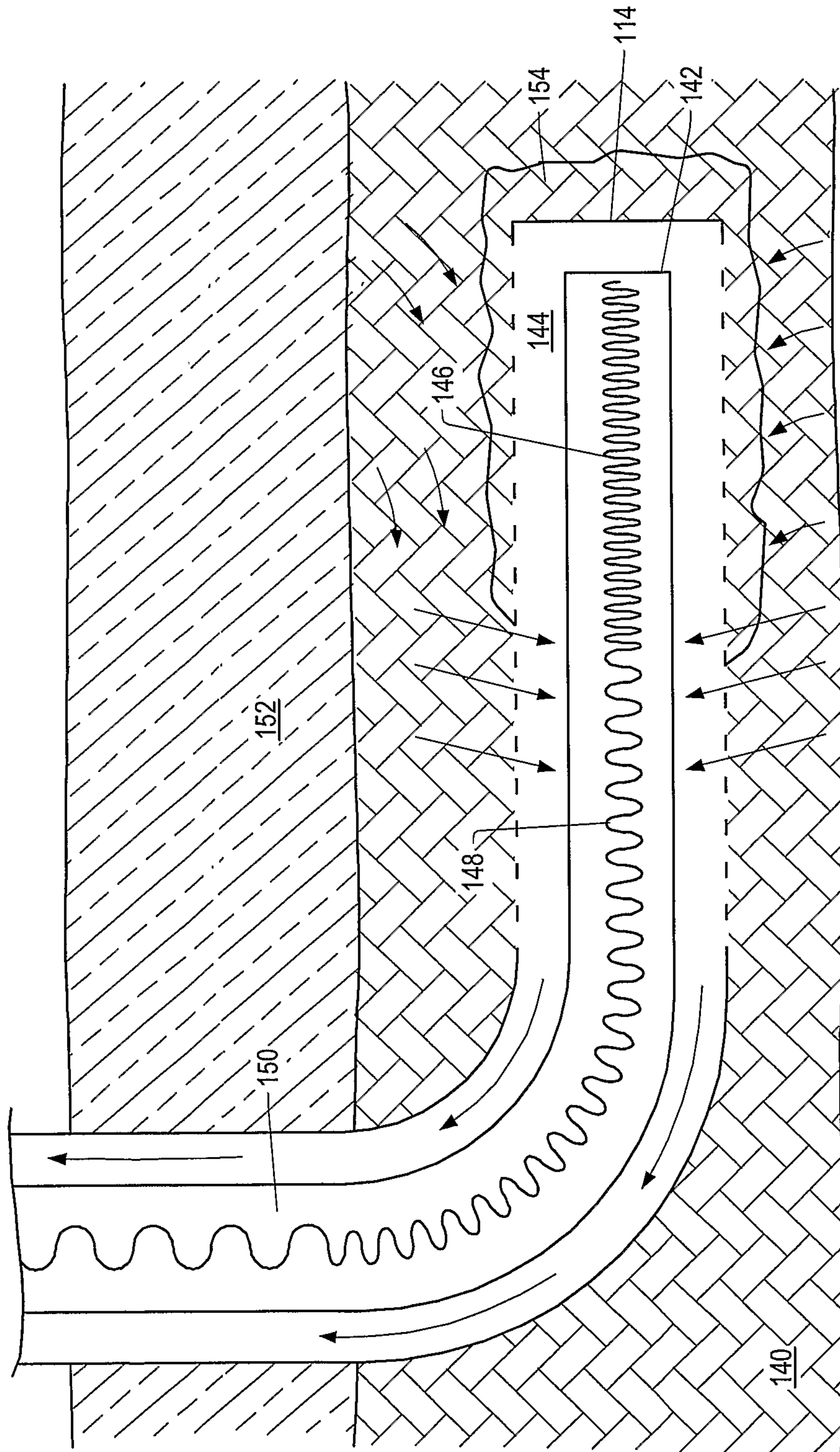

FIG. 7

7/19

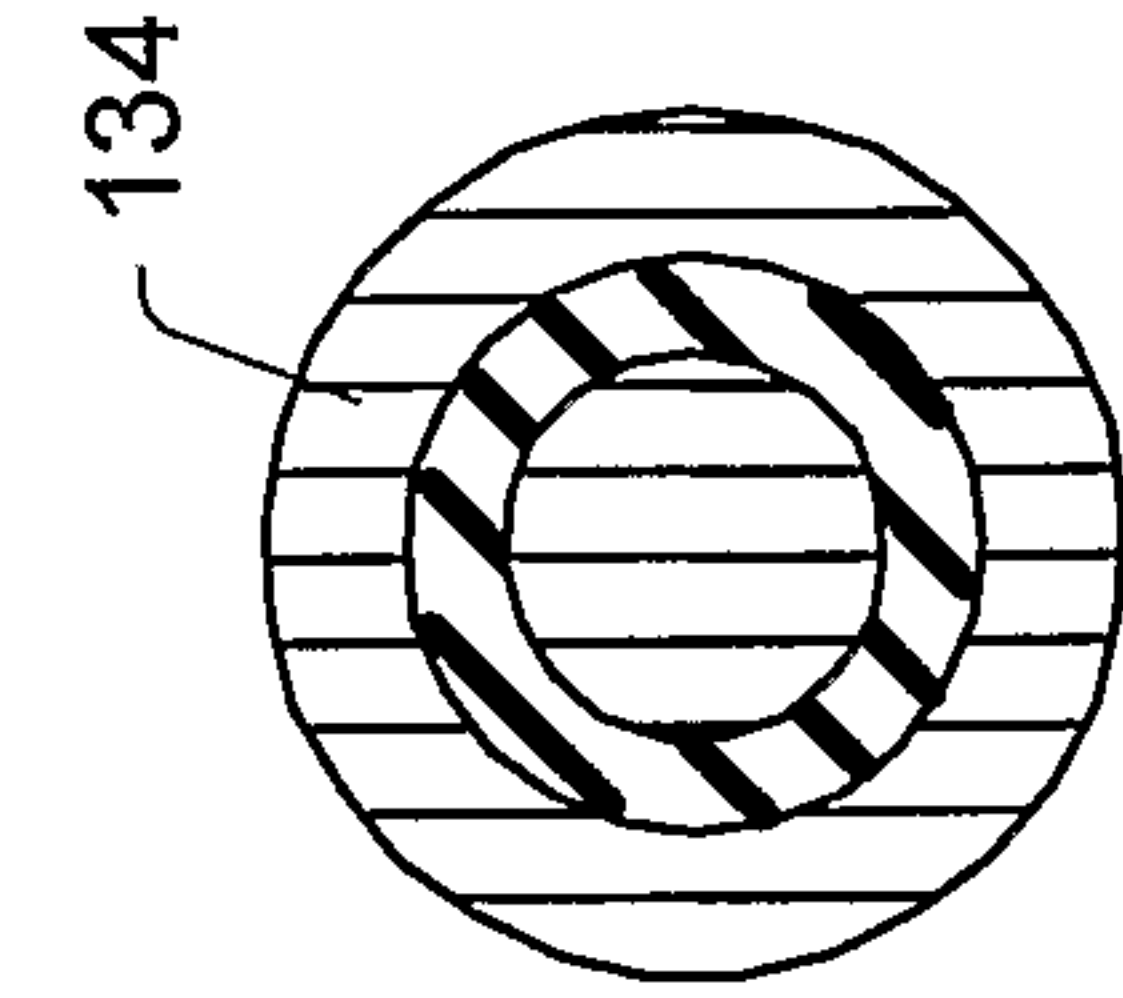

FIG. 10

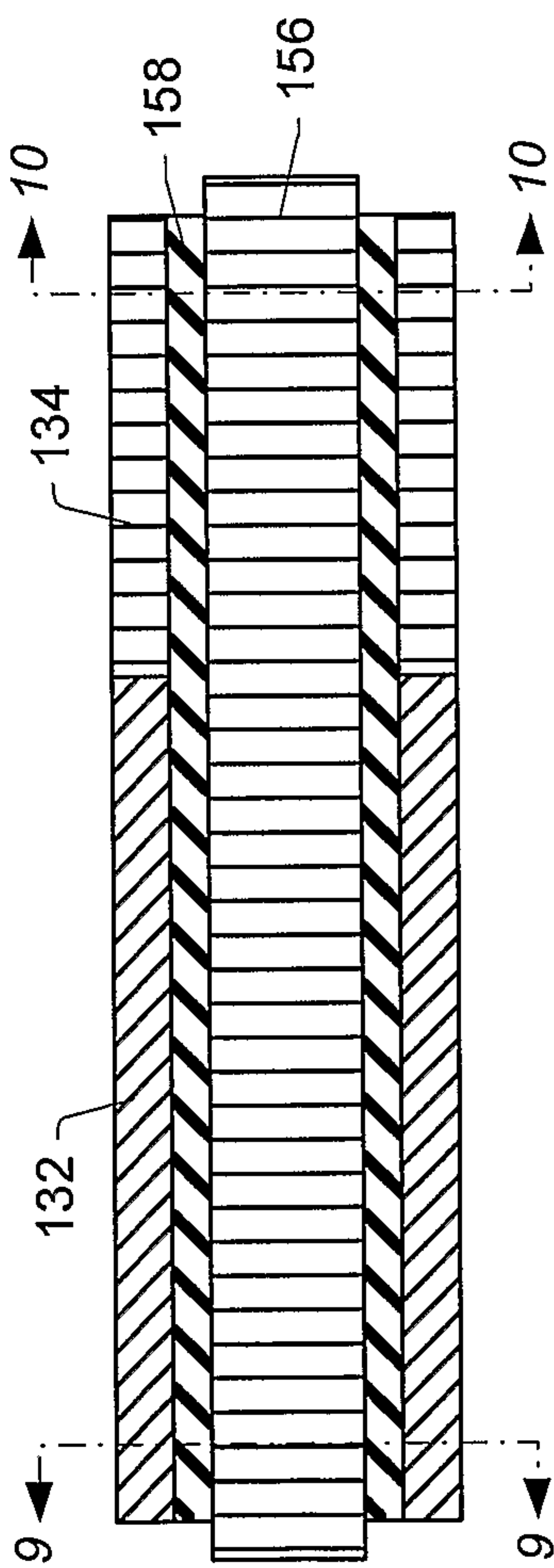

FIG. 8

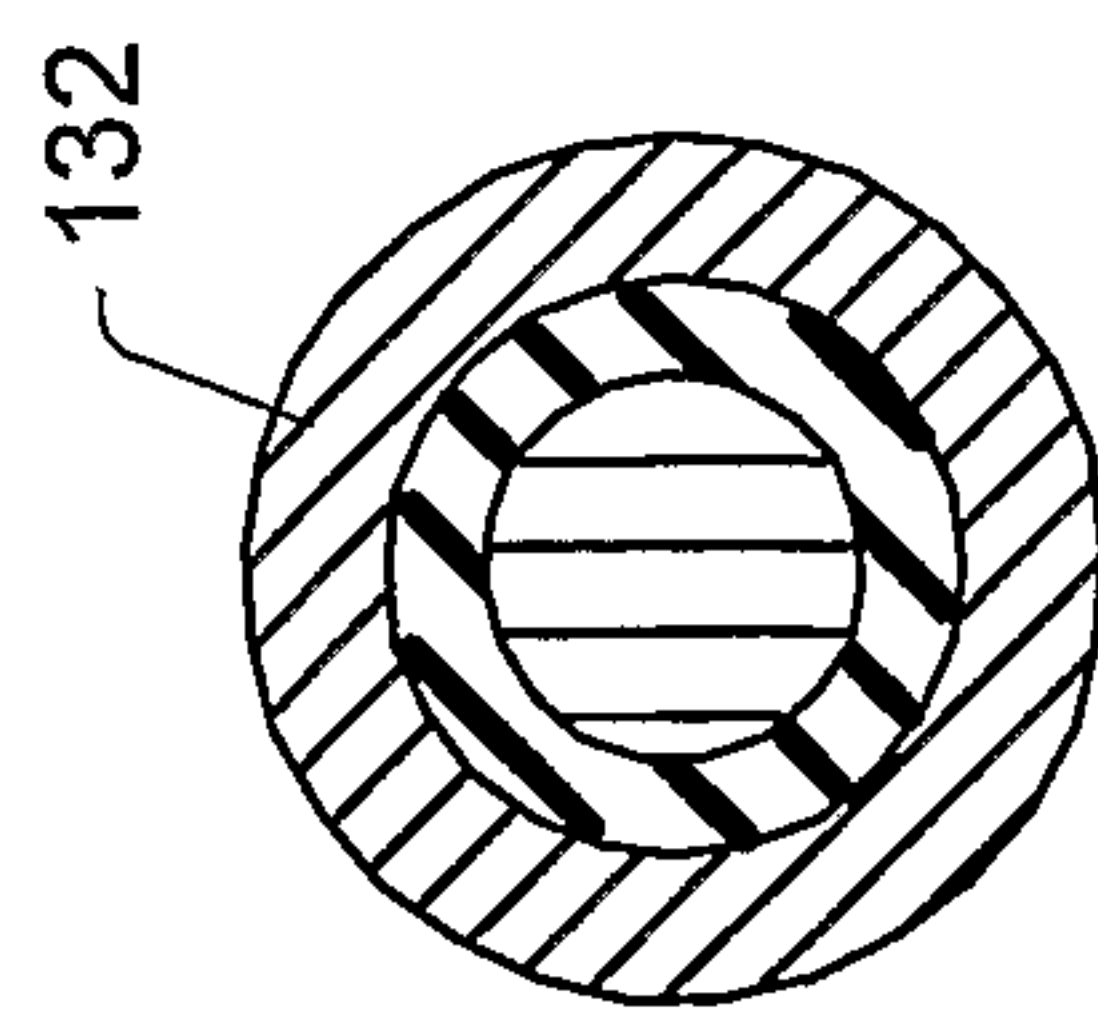

FIG. 9

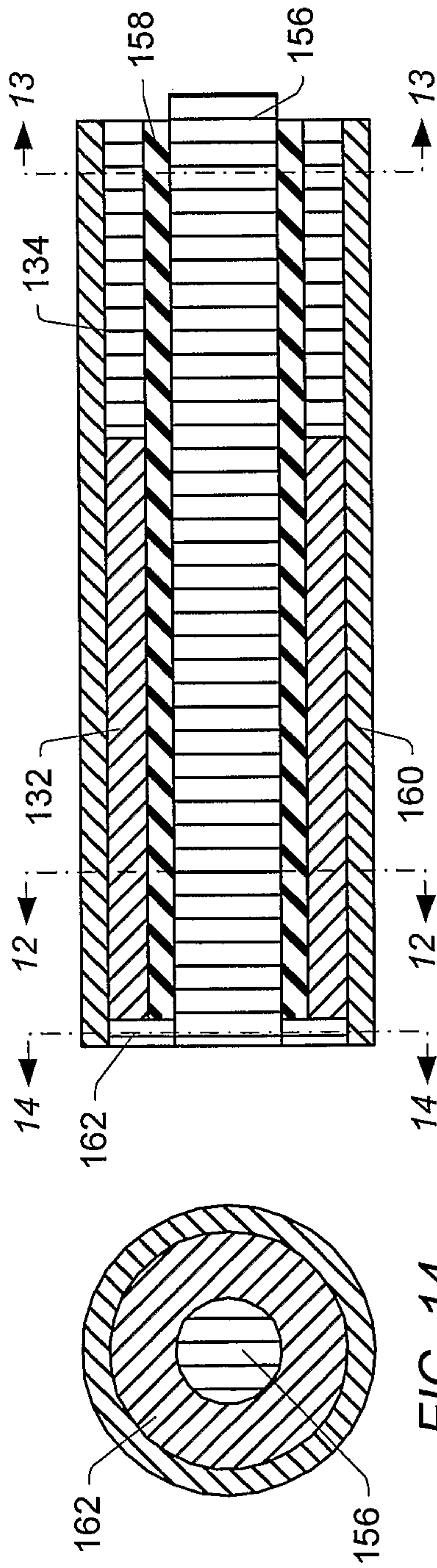

FIG. 11

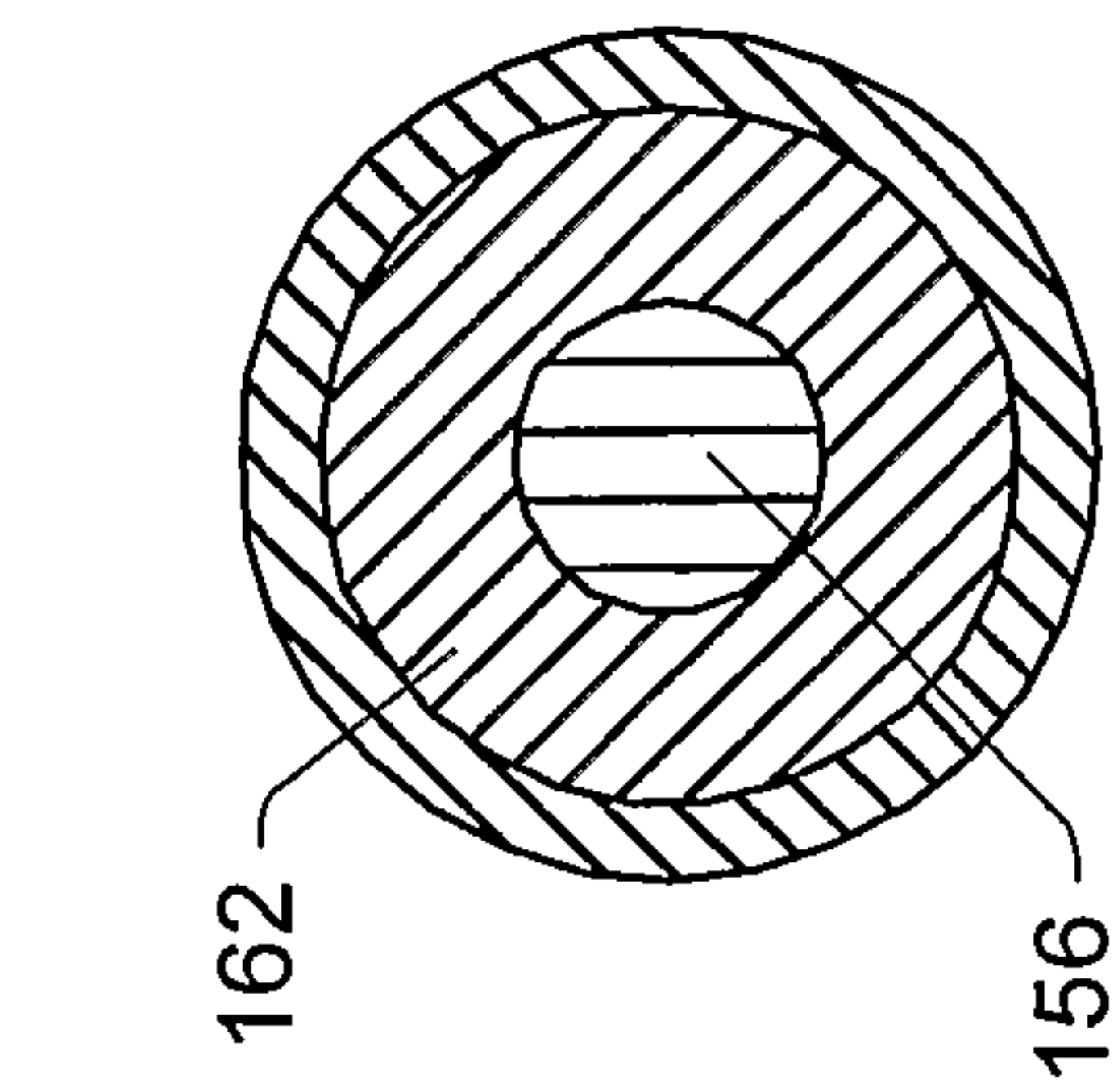

FIG. 14

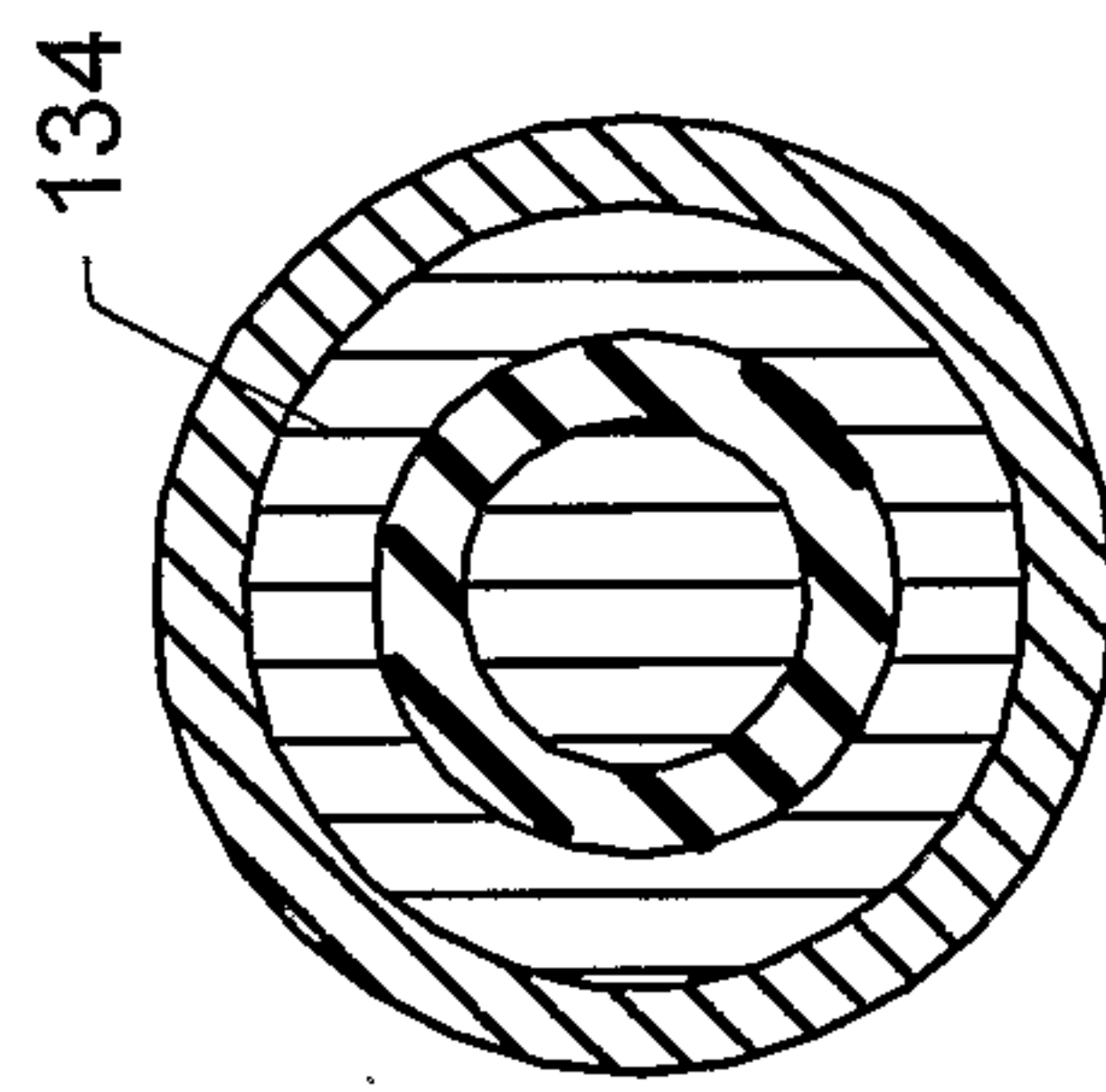

FIG. 13

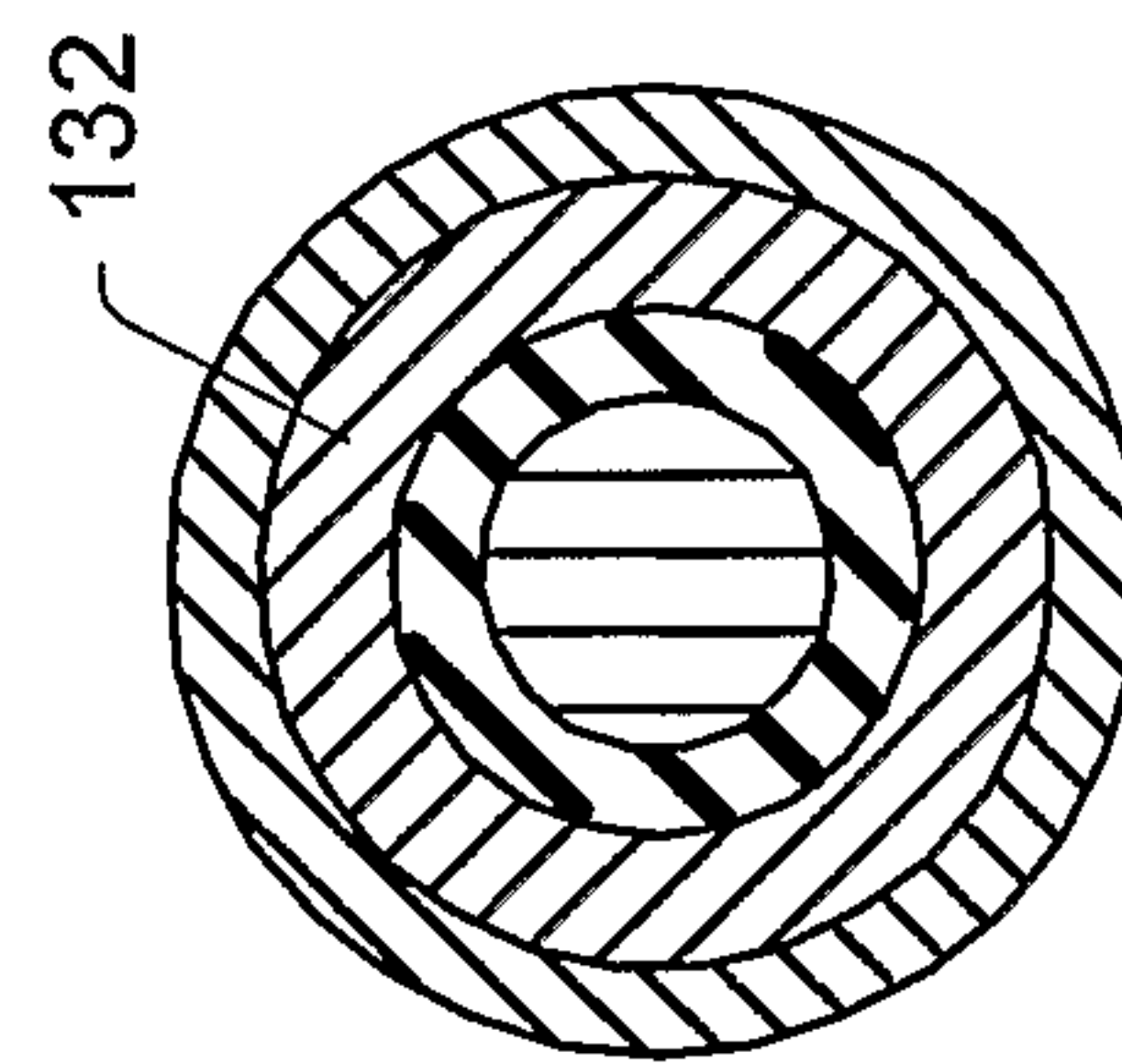

FIG. 12

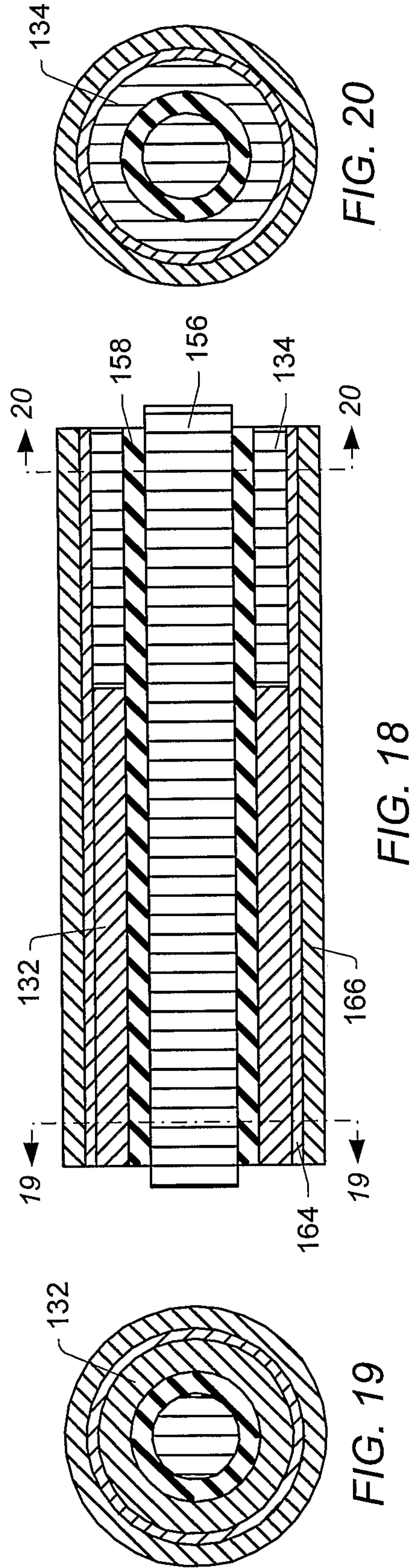
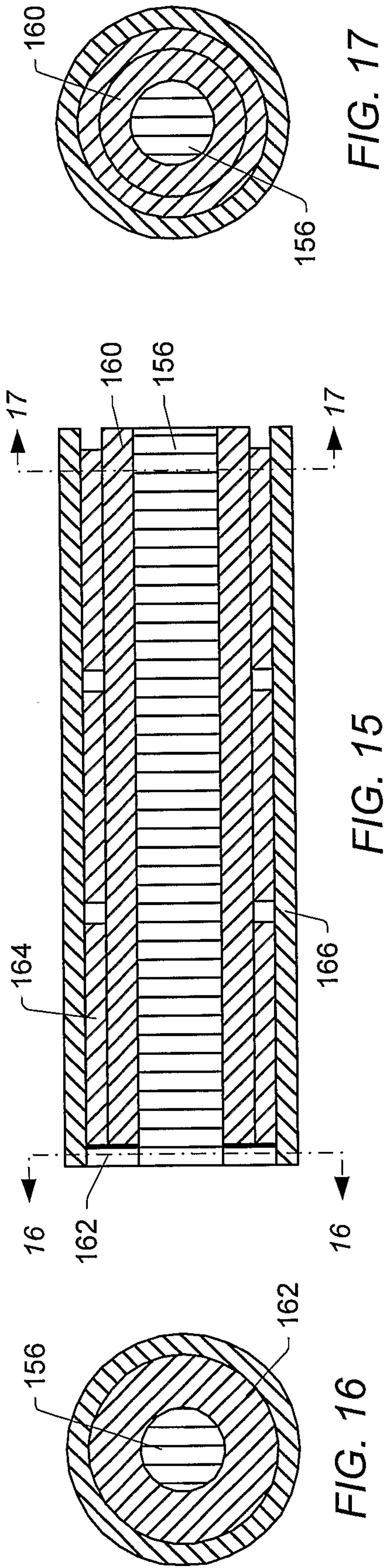

FIG. 16

FIG. 15

FIG. 17

FIG. 19

FIG. 18

FIG. 20

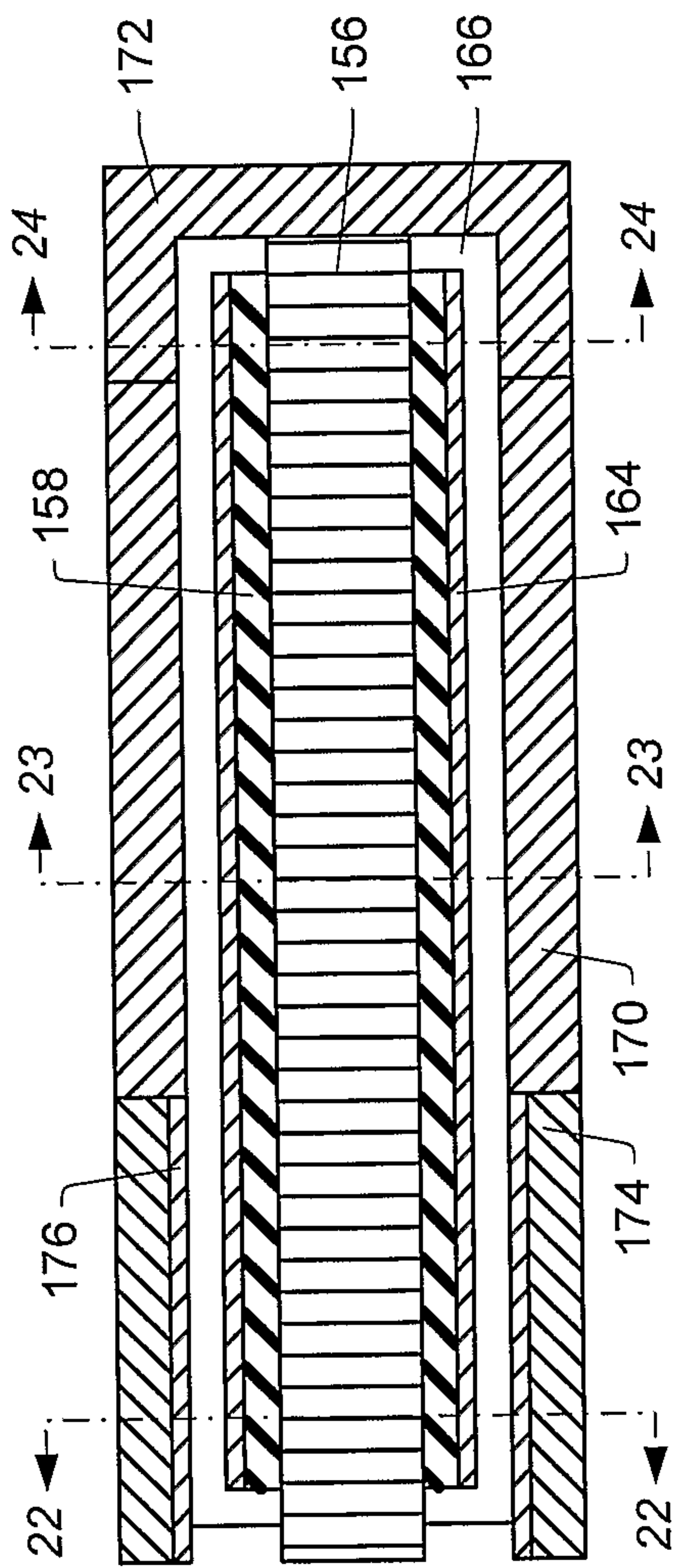

FIG. 21

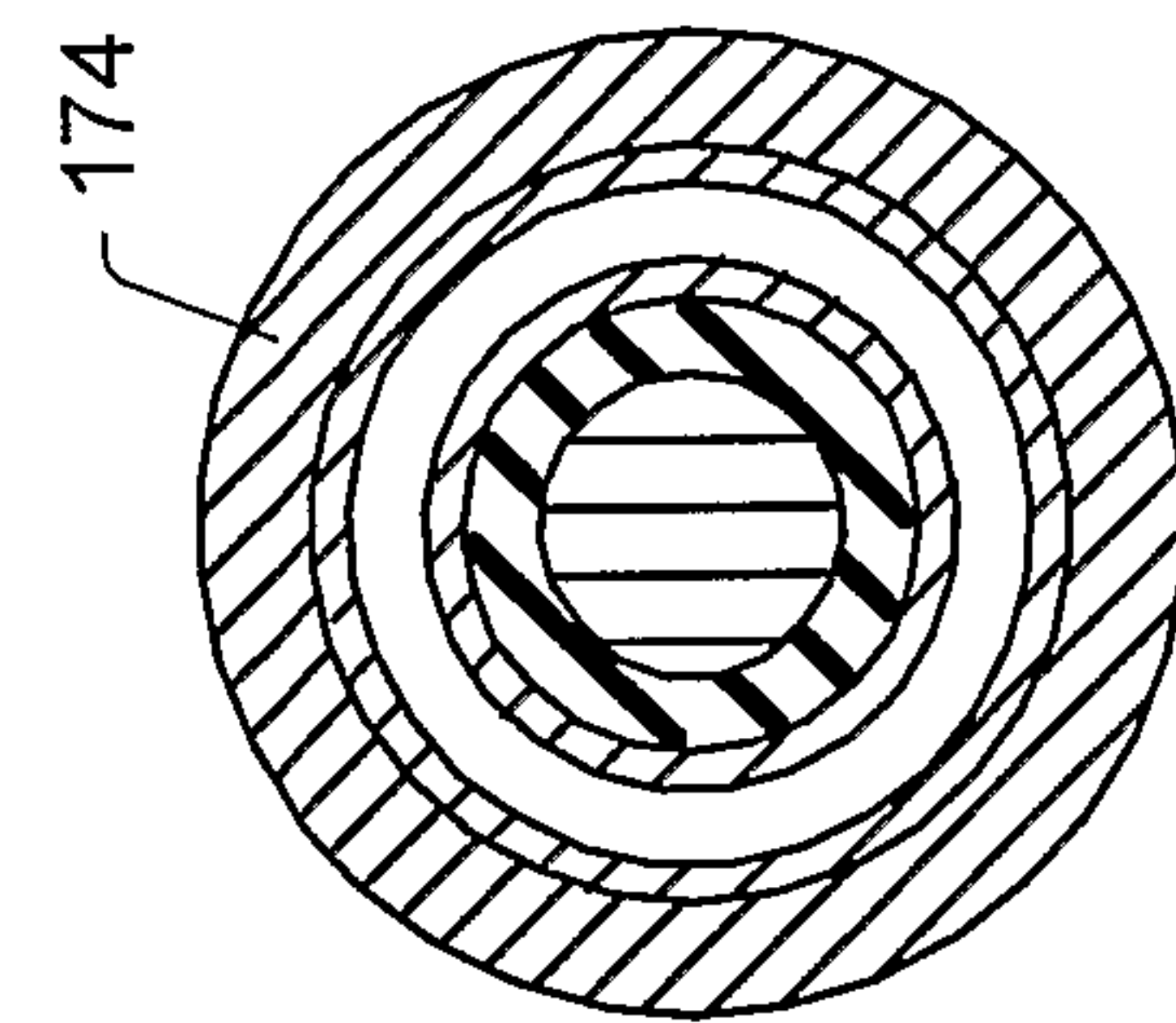

FIG. 22

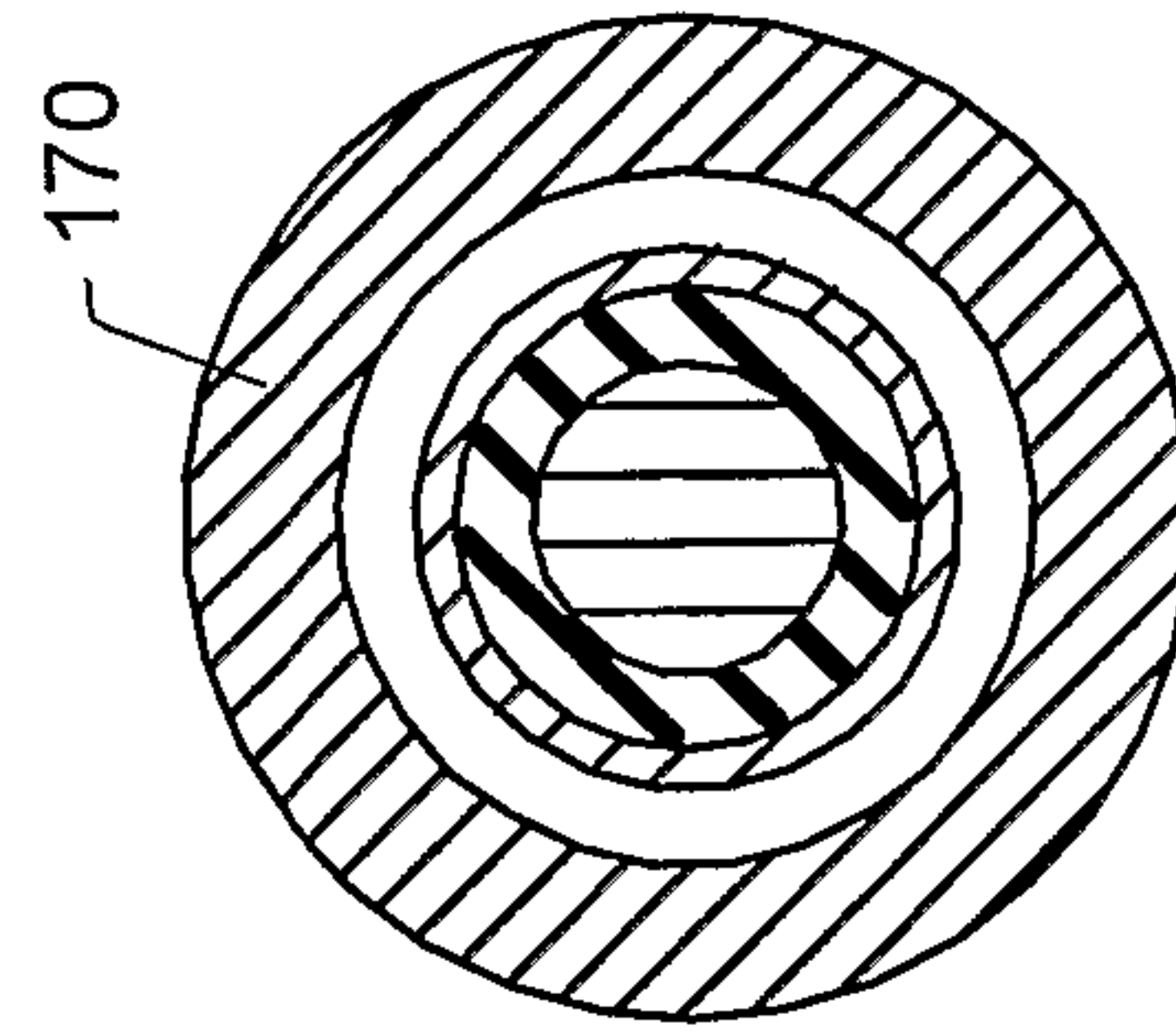

FIG. 23

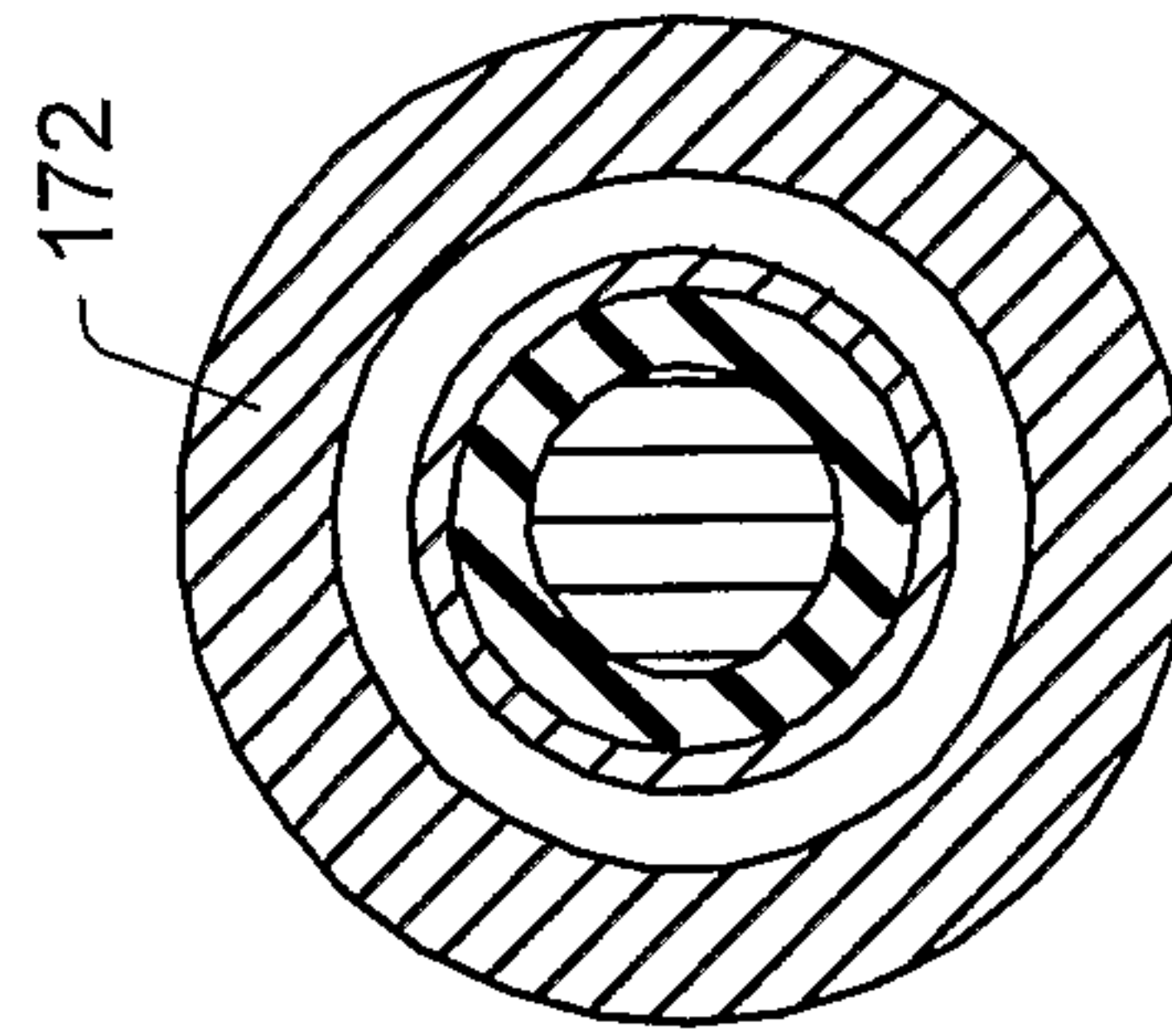

FIG. 24

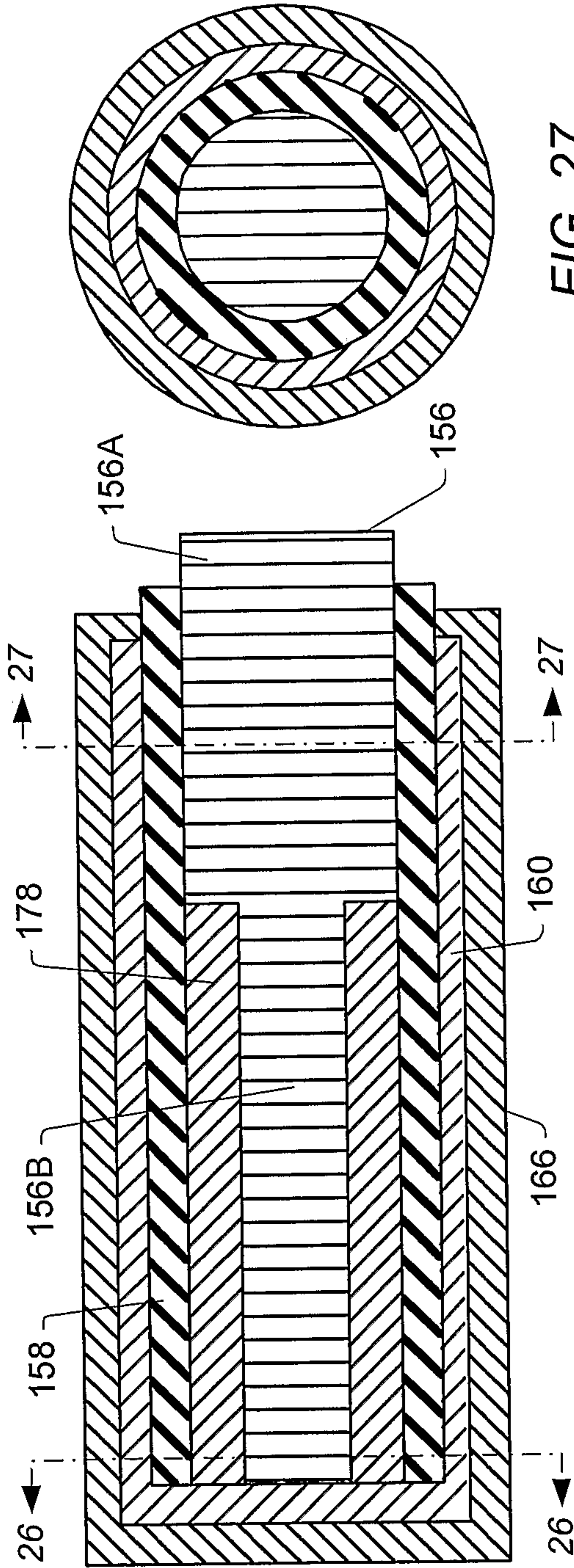

FIG. 27

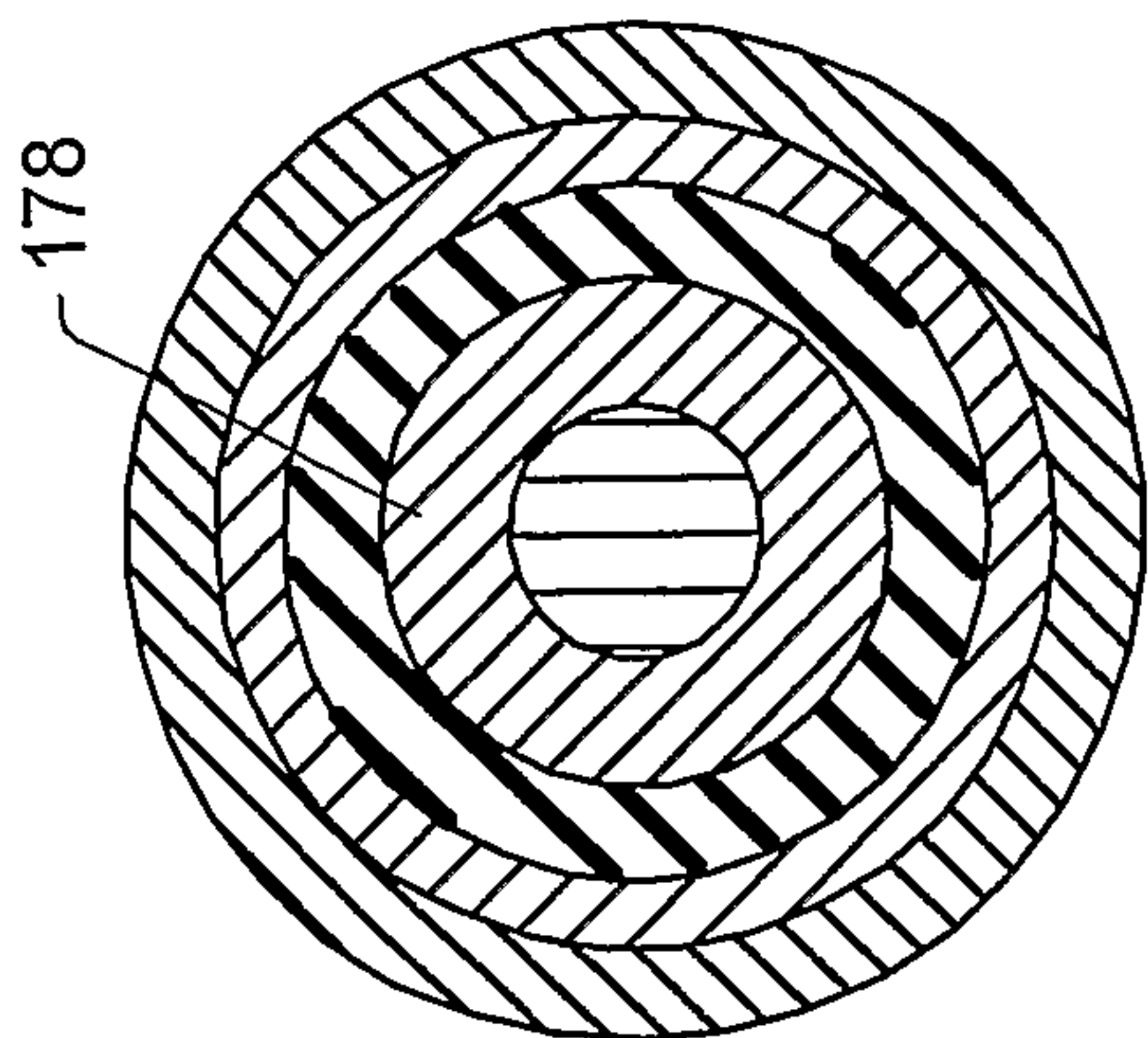

FIG. 26

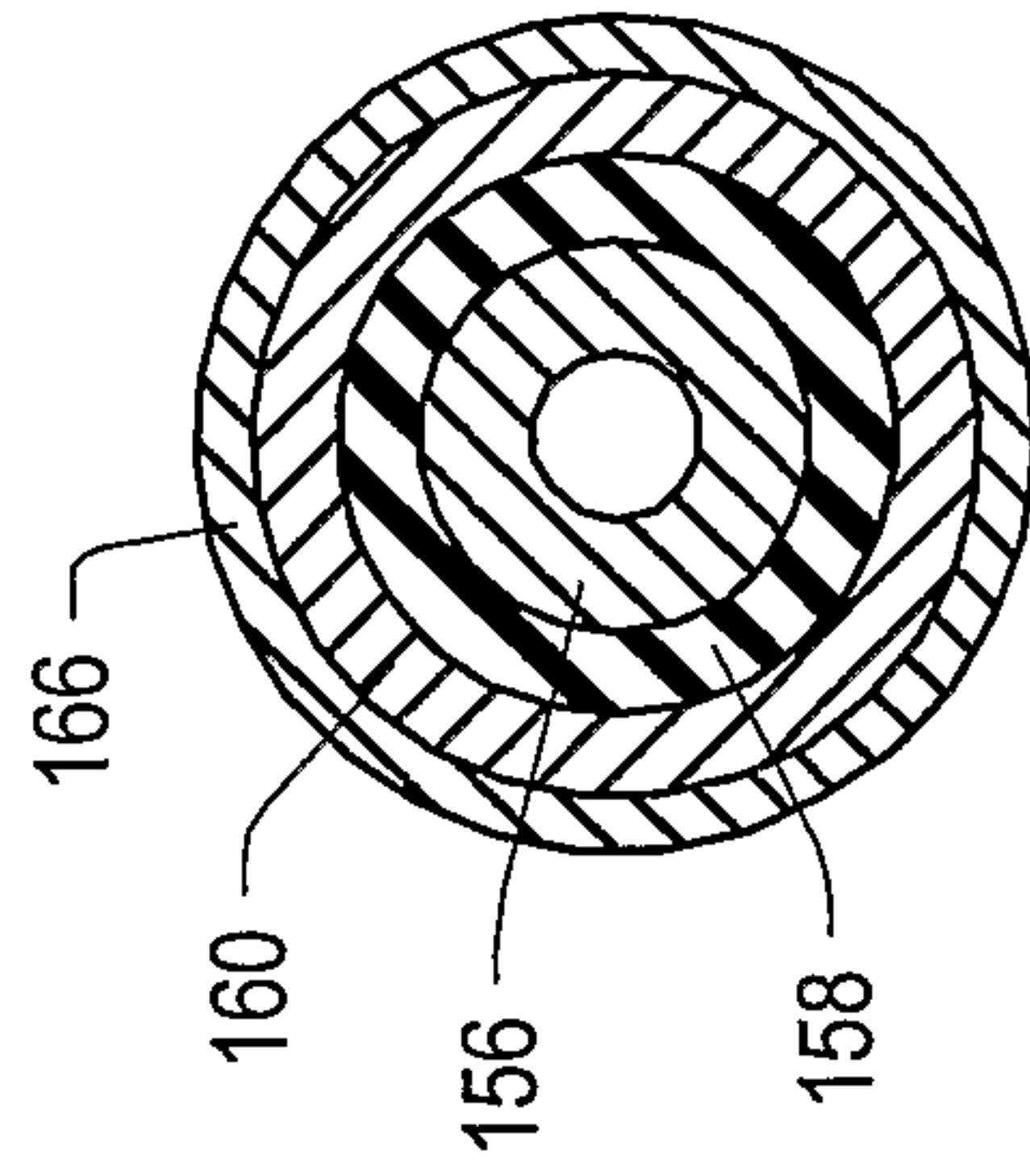

FIG. 28B

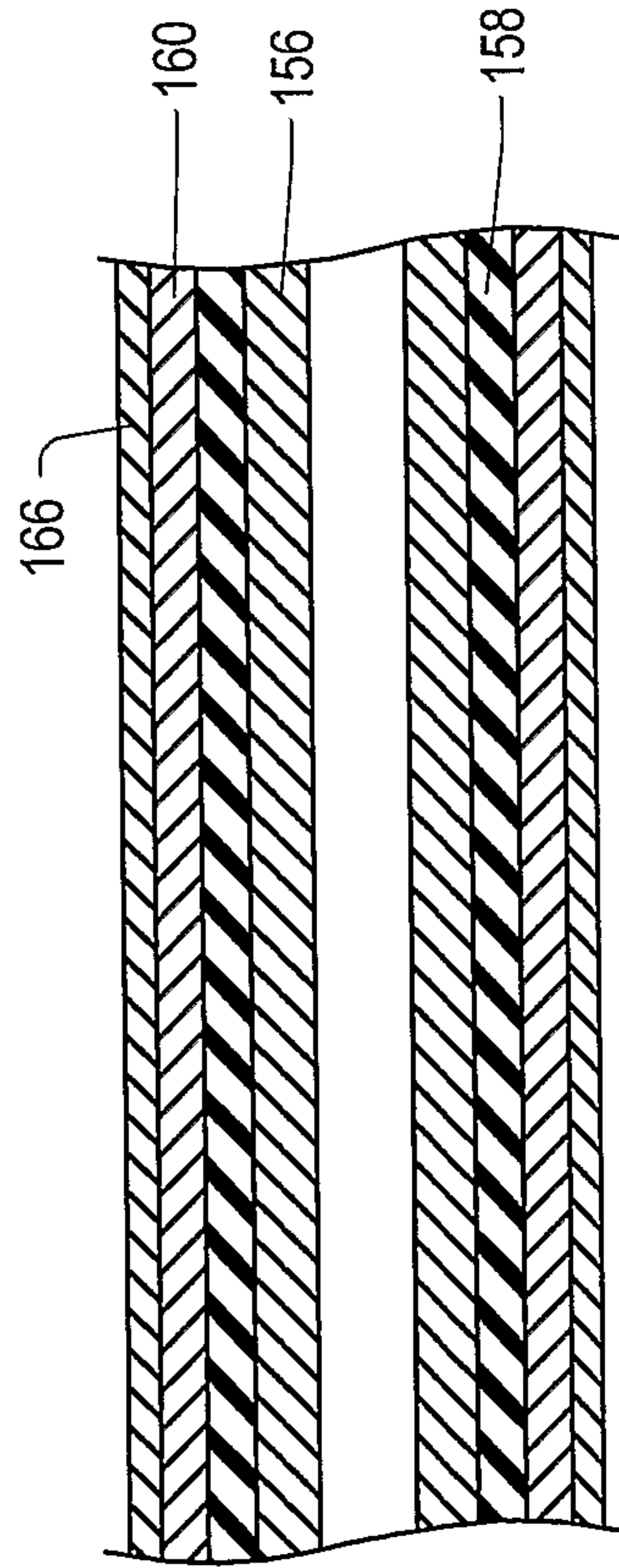

FIG. 28A

FIG. 25

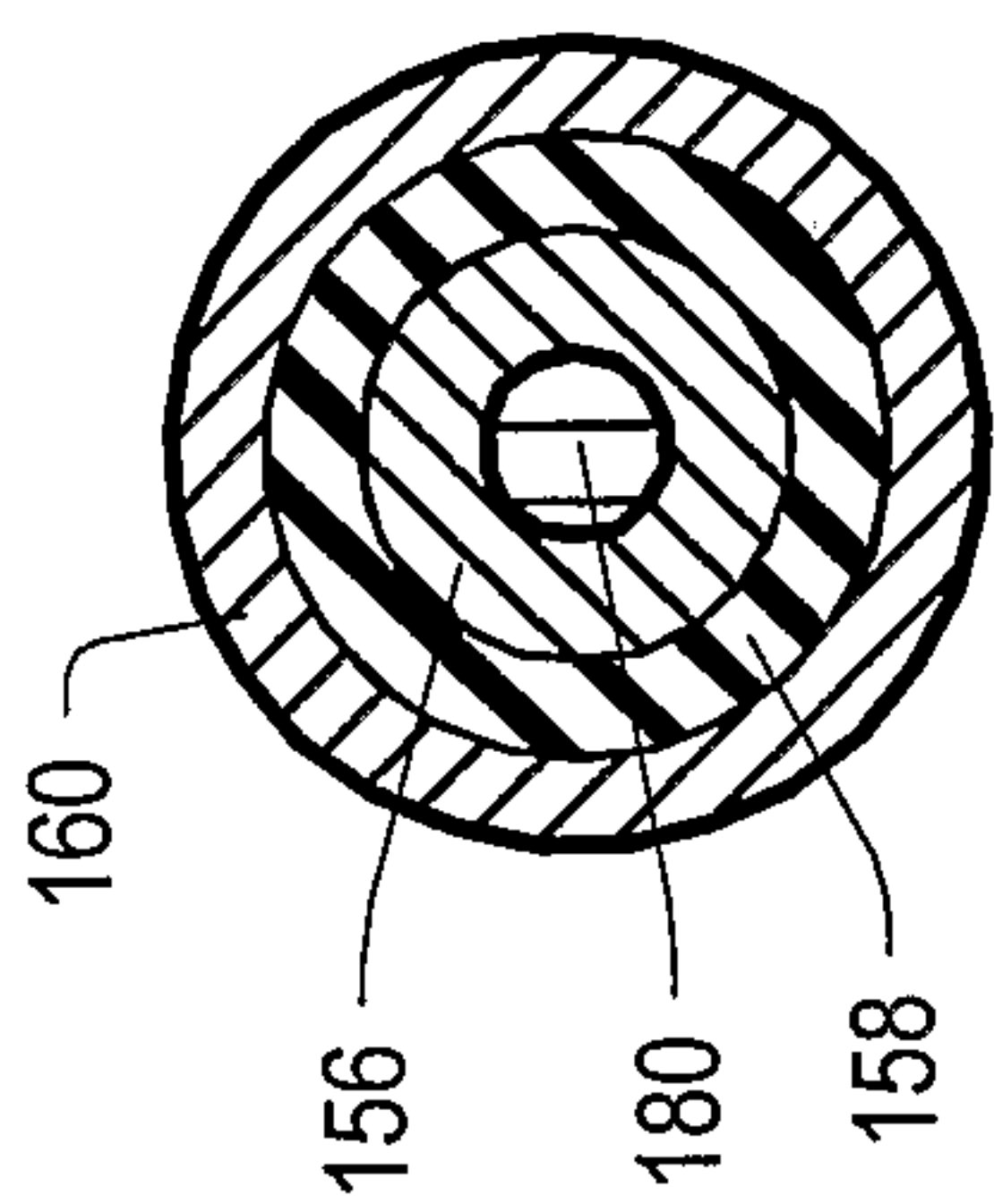

FIG. 29B

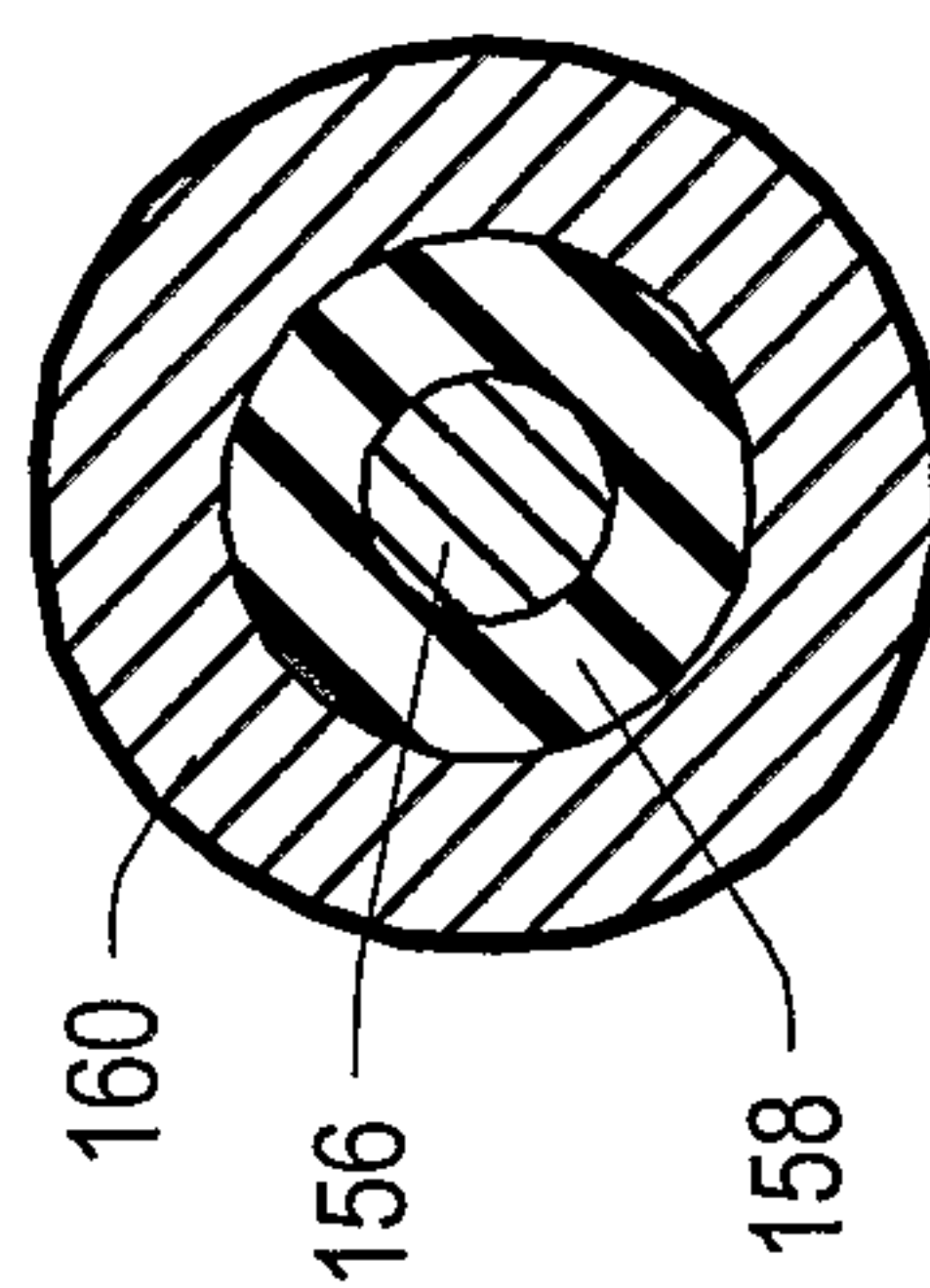

FIG. 30B

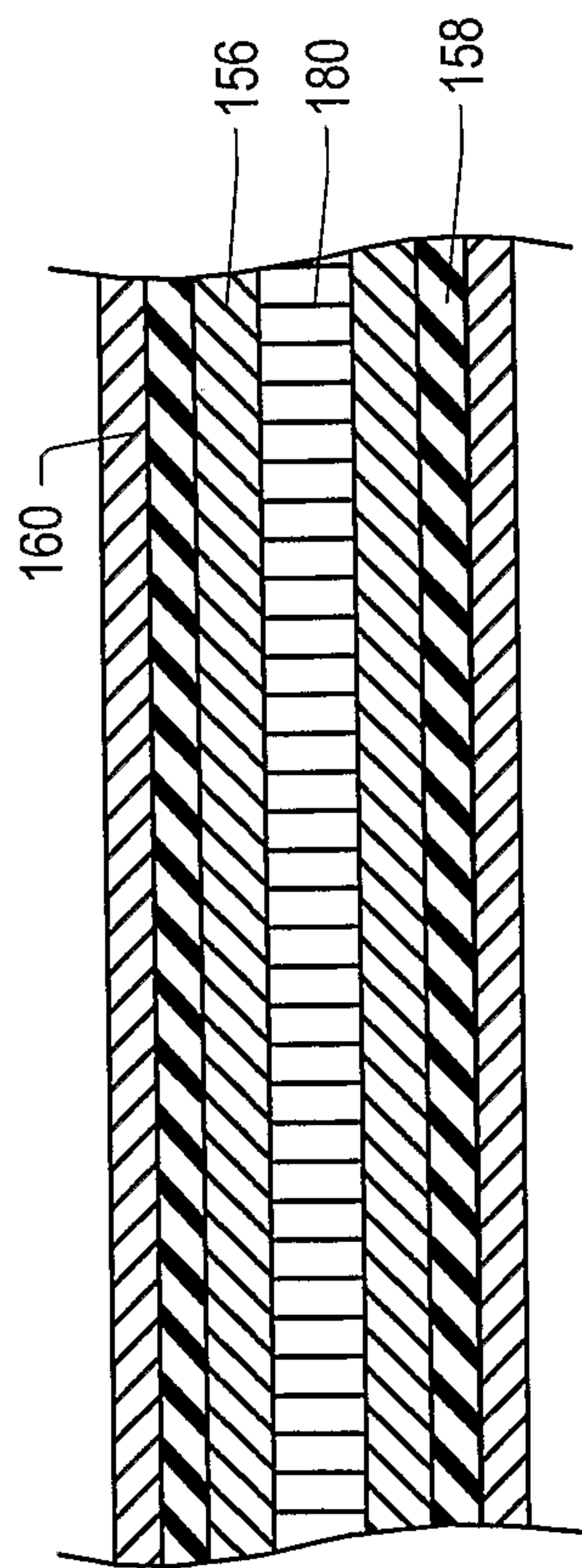

FIG. 29A

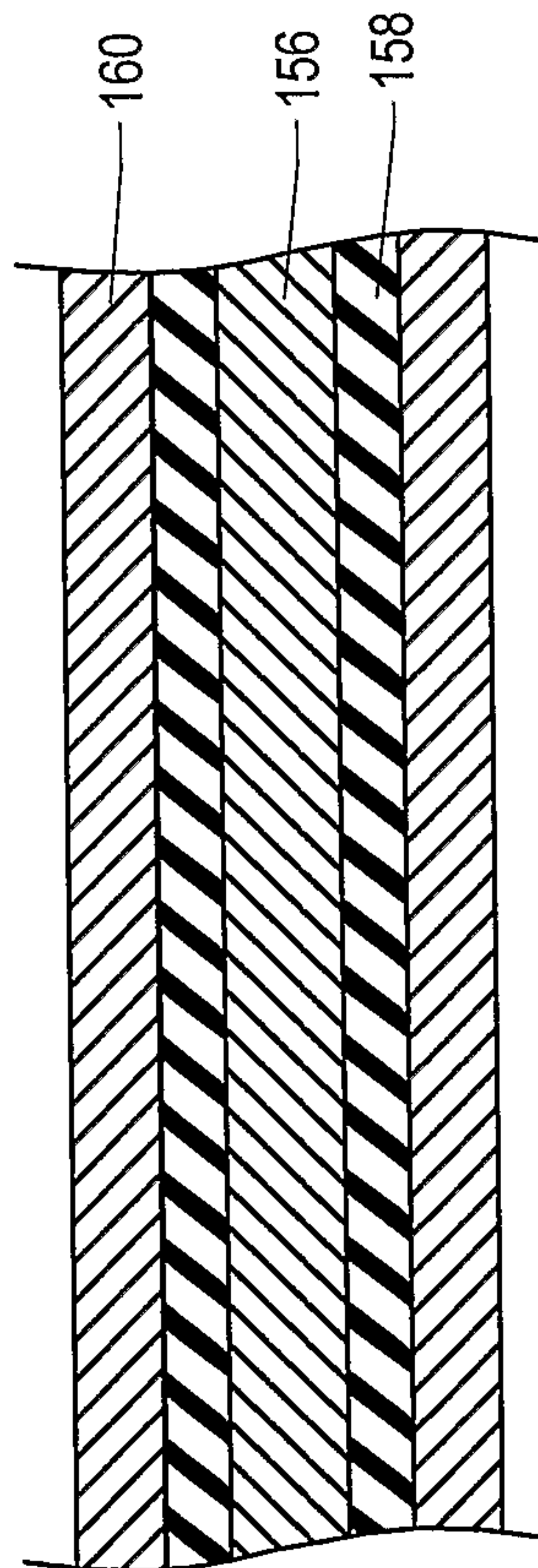

FIG. 30A

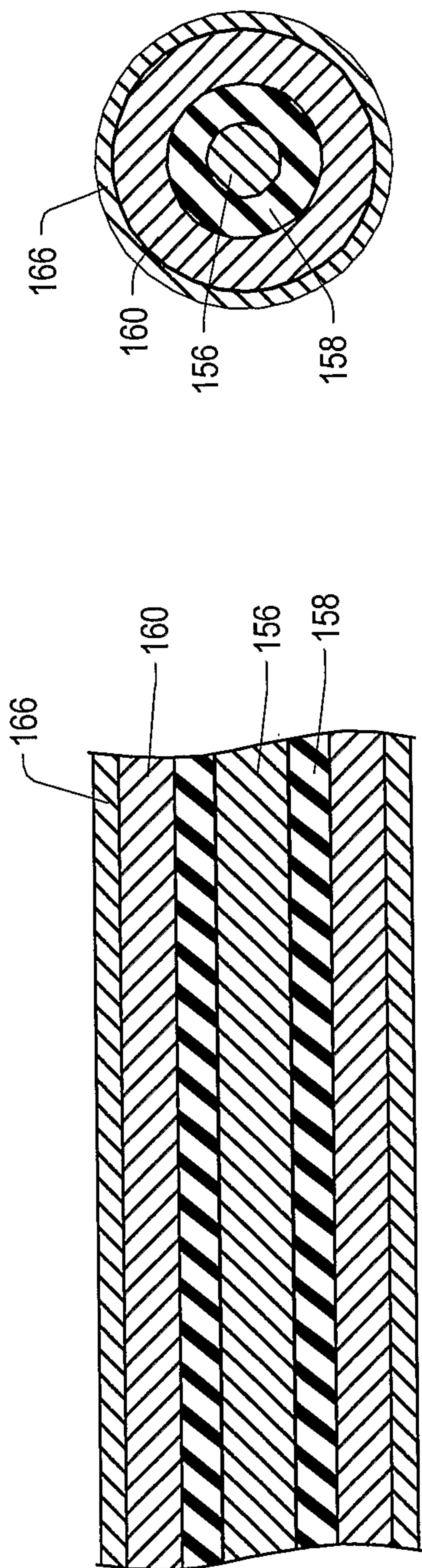

FIG. 31A

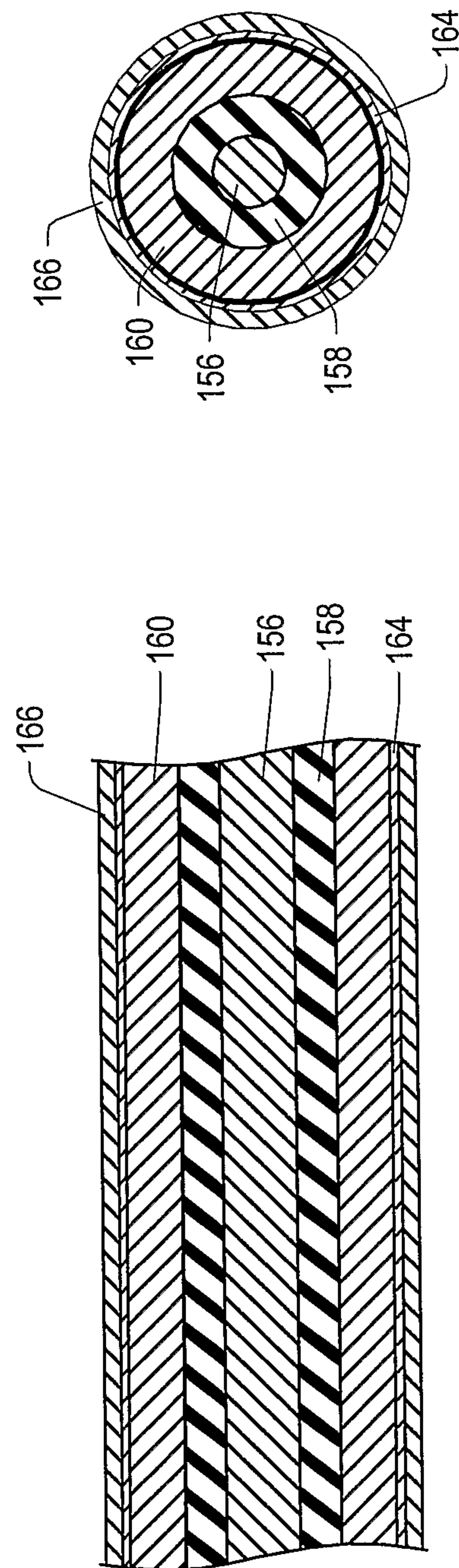

FIG. 32A

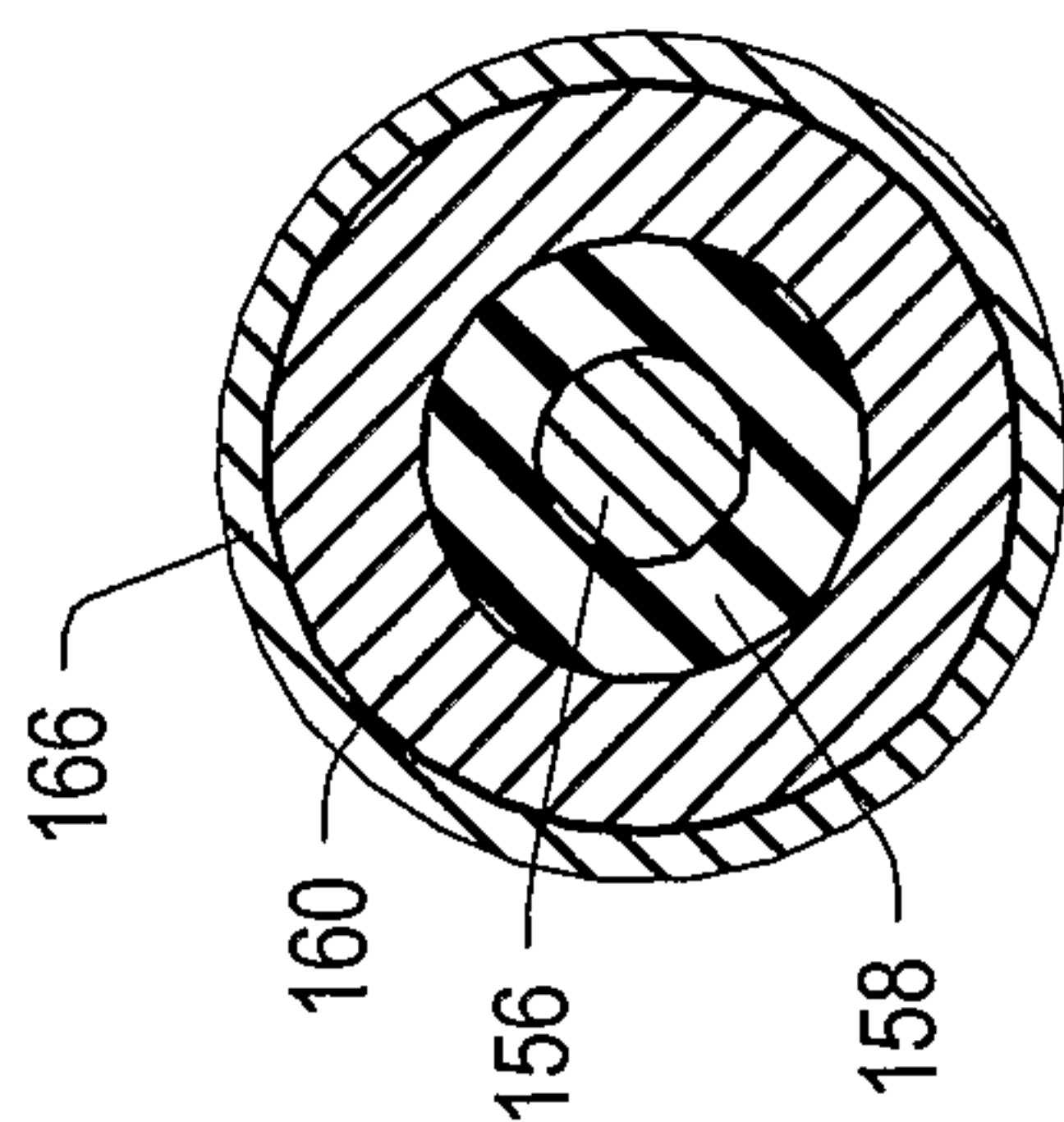

FIG. 31B

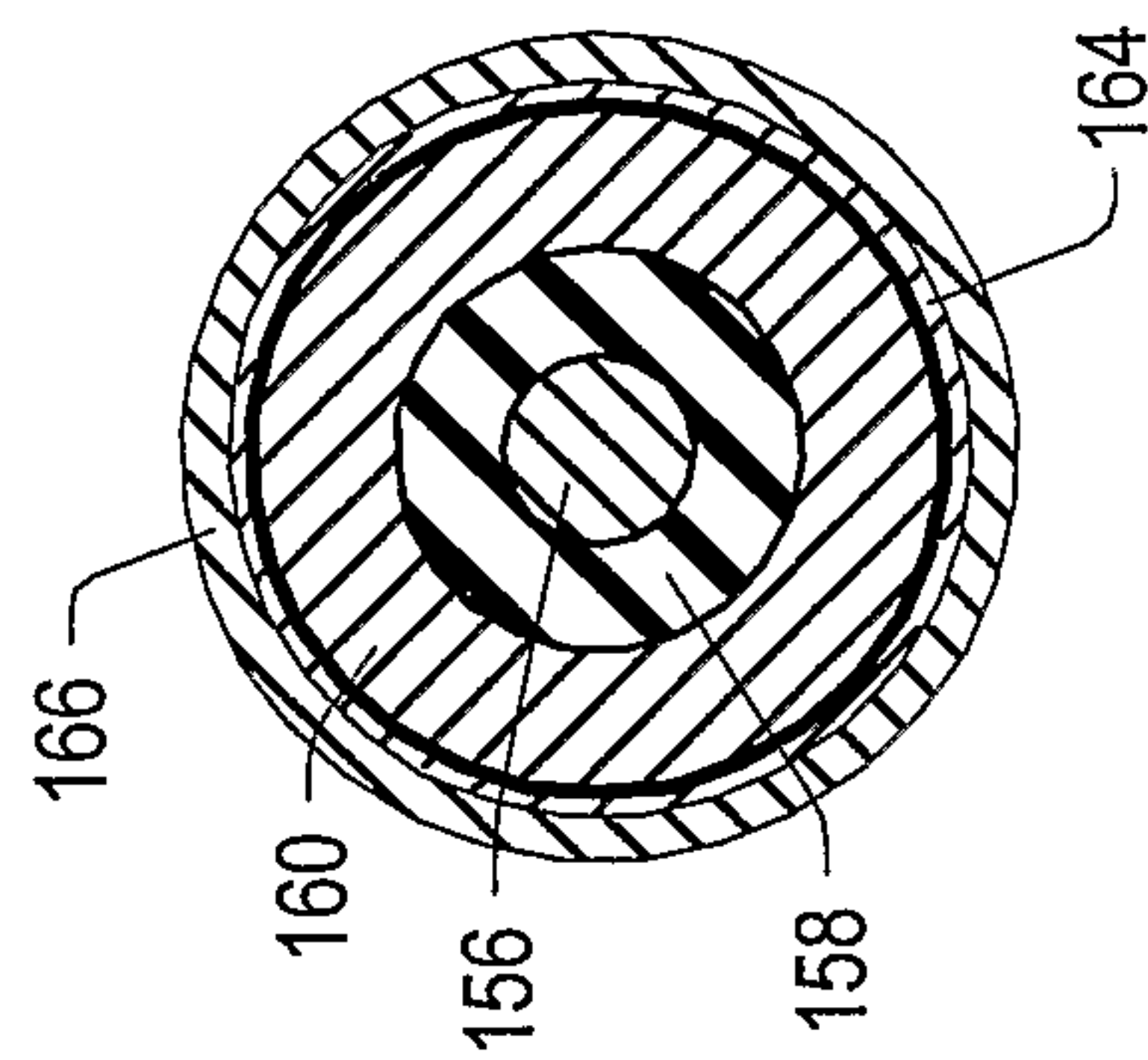

FIG. 32B

FIG. 34

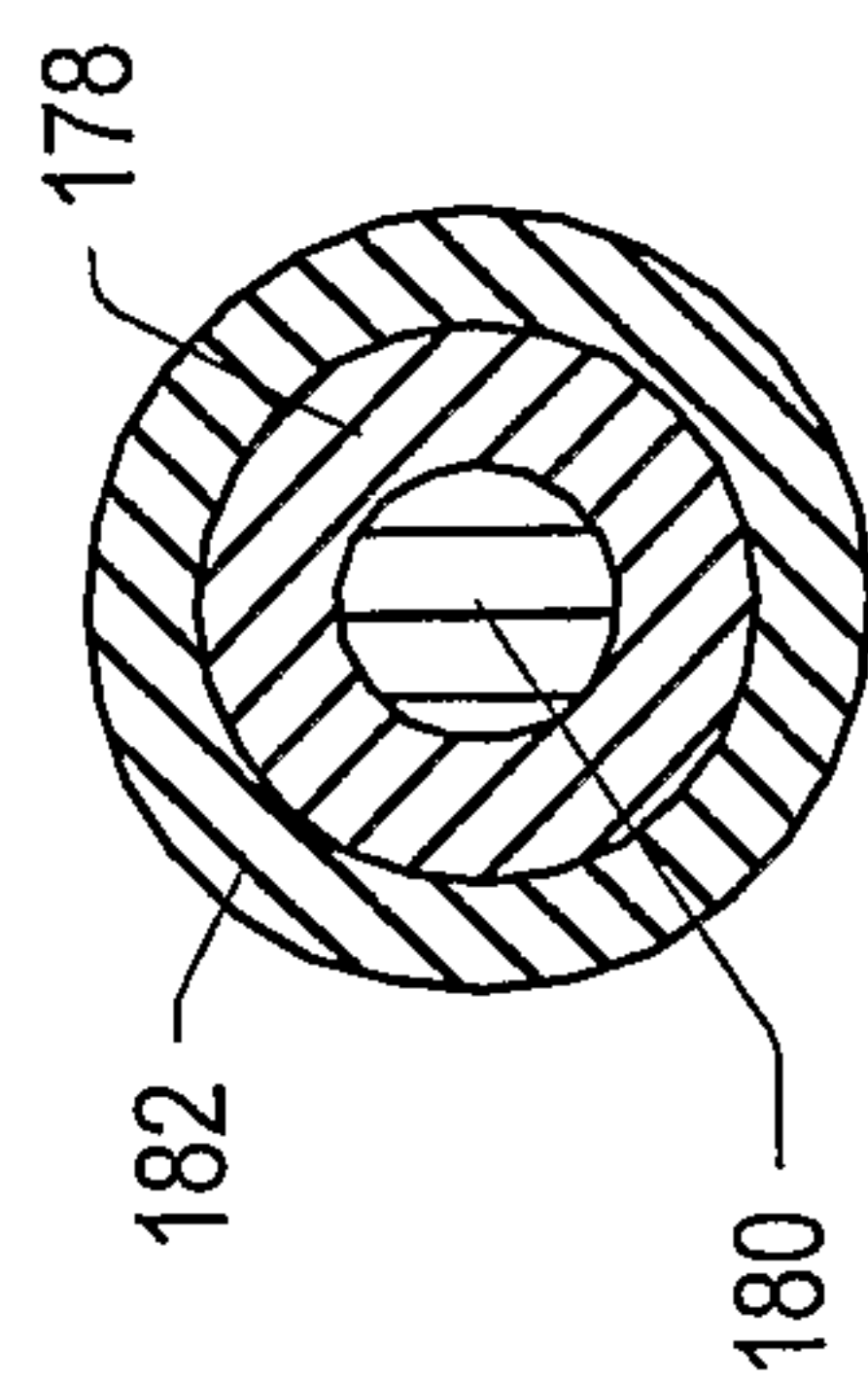
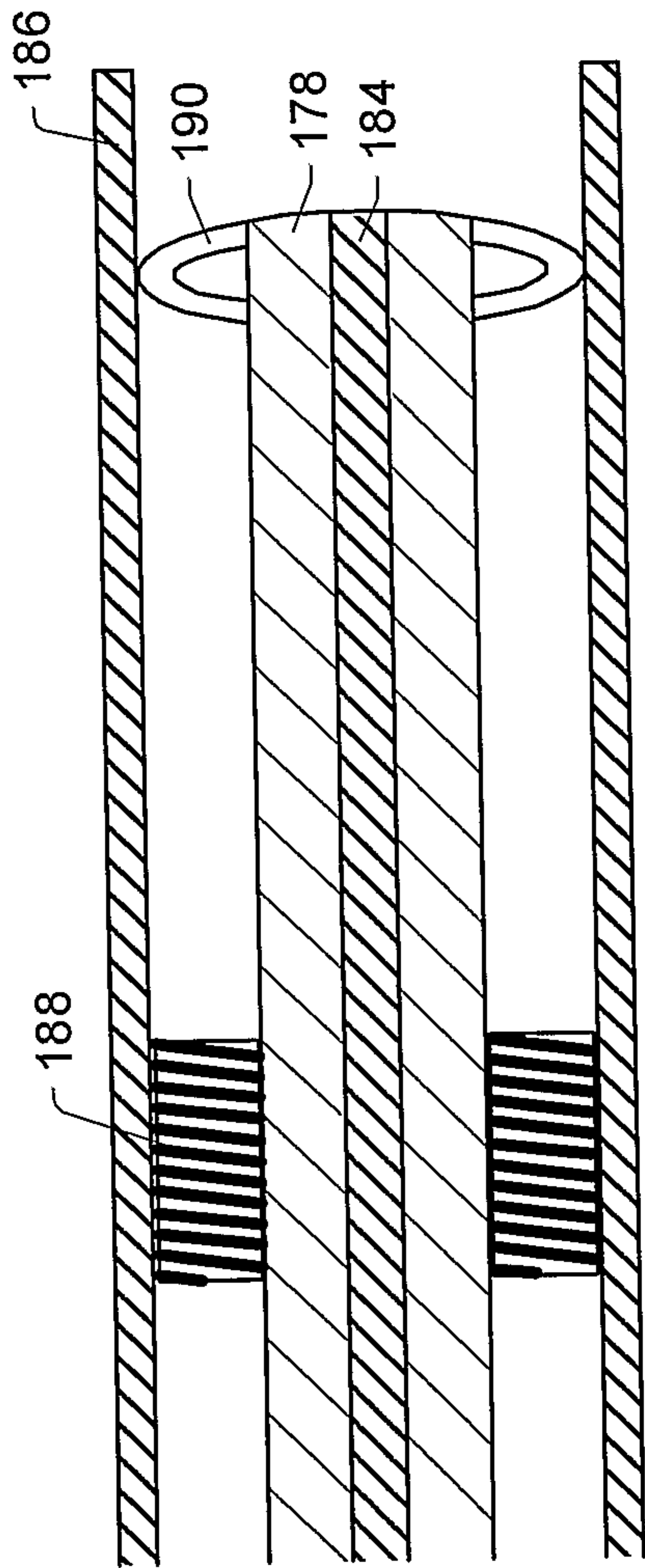

FIG. 33

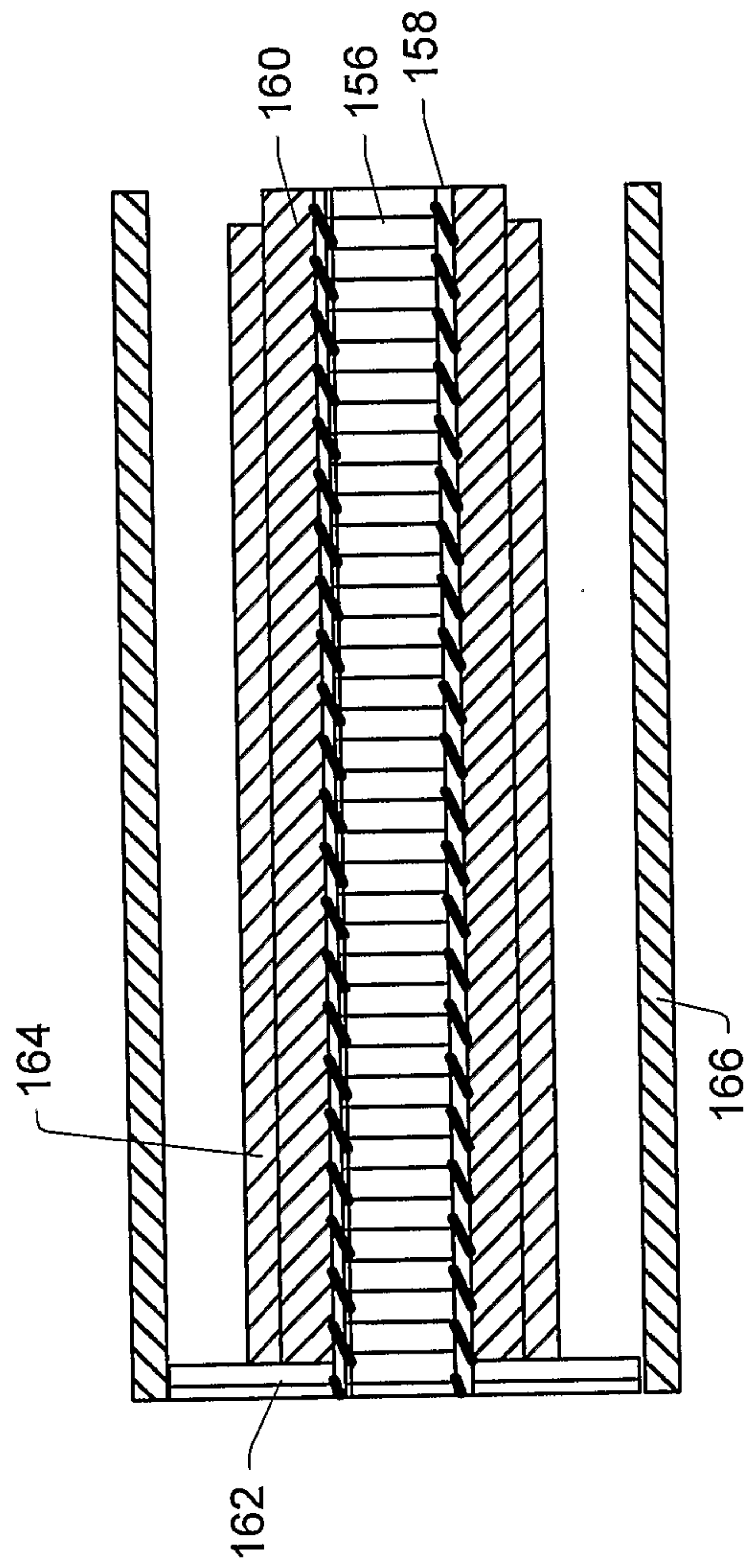

FIG. 35

15/19

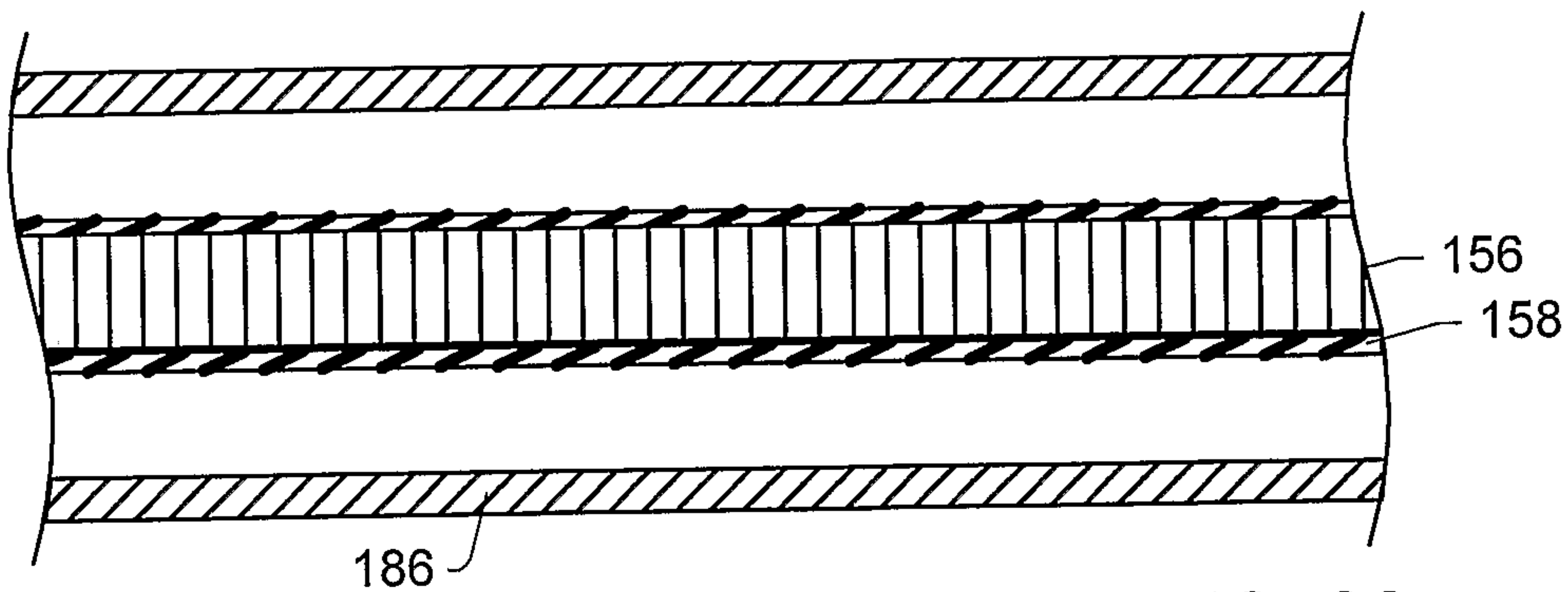

FIG. 36

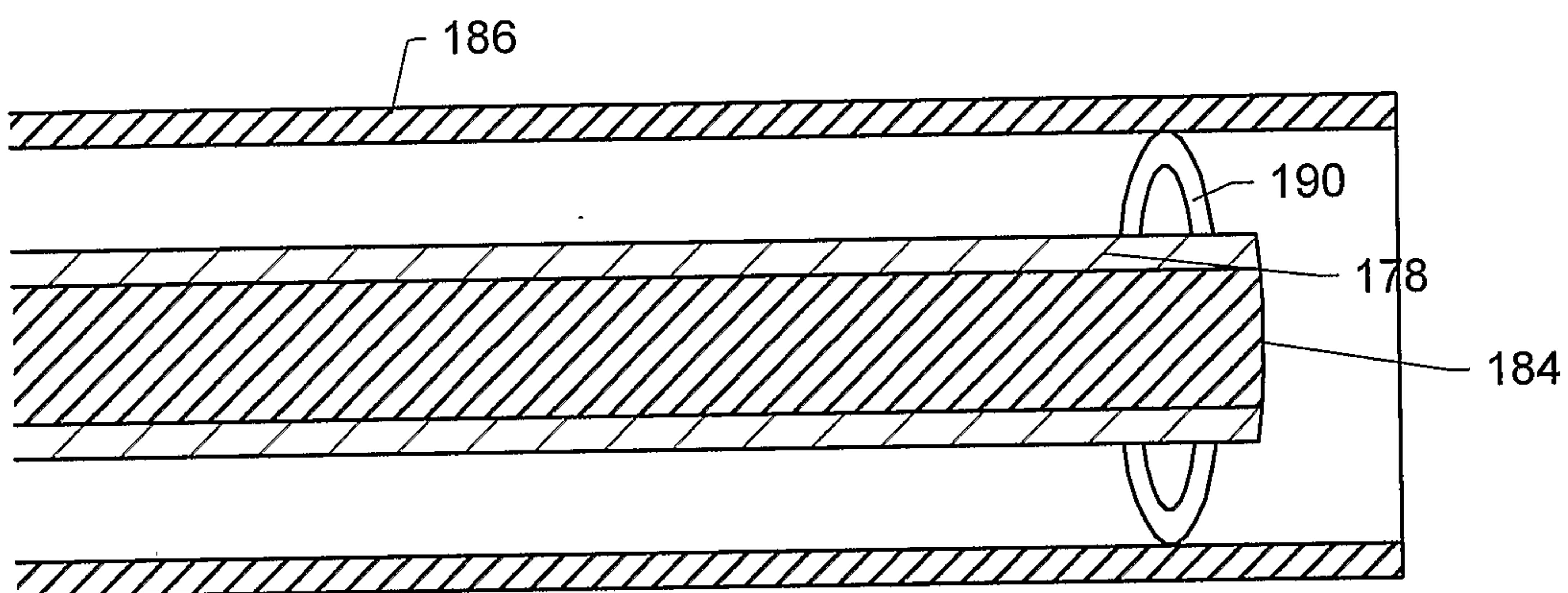

FIG. 37

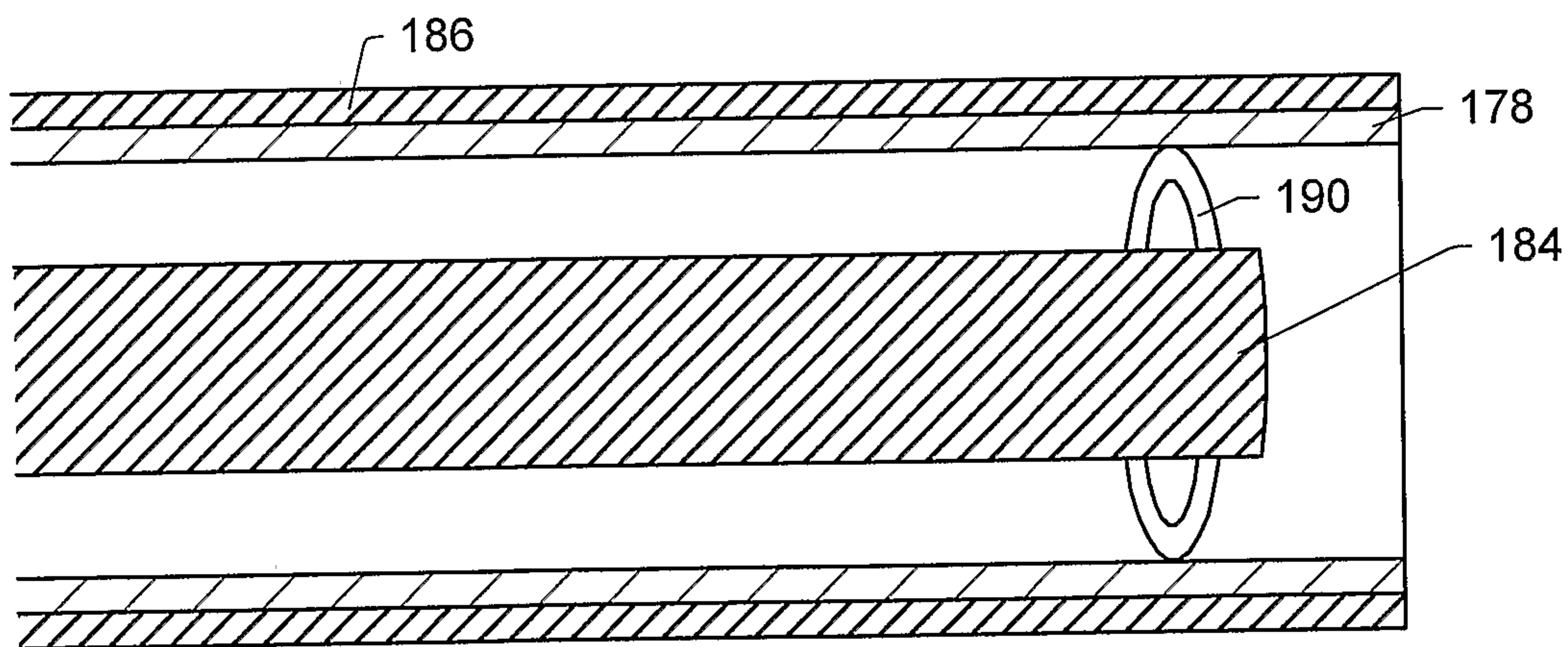

FIG. 38

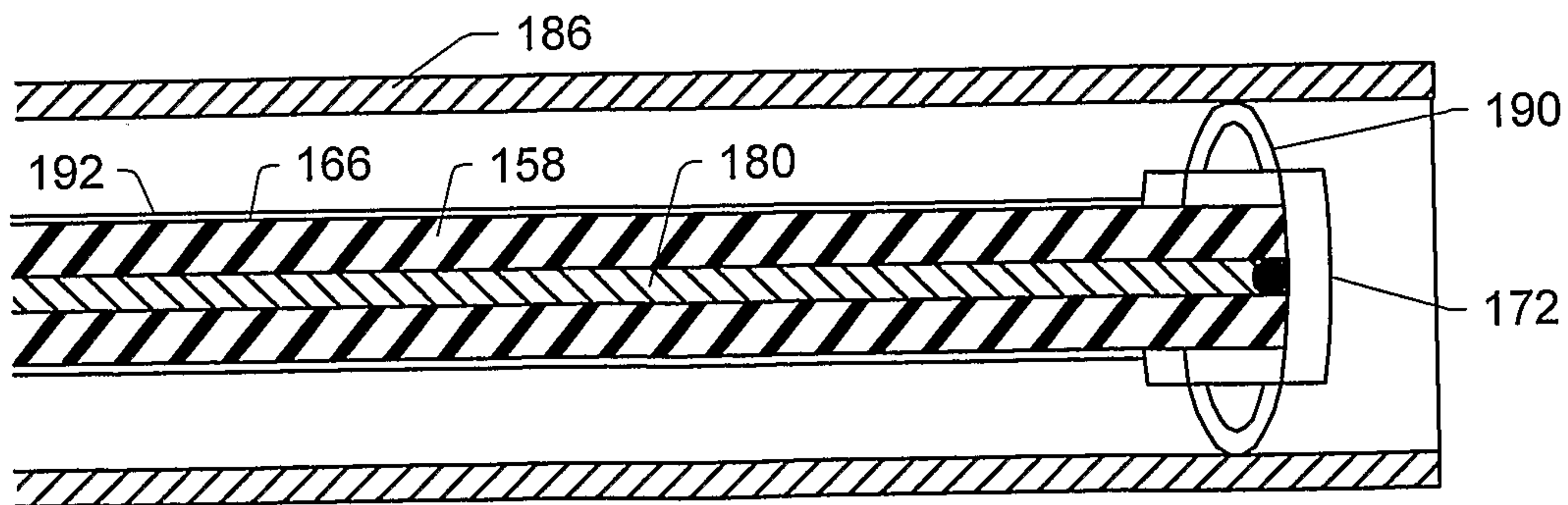

FIG. 39

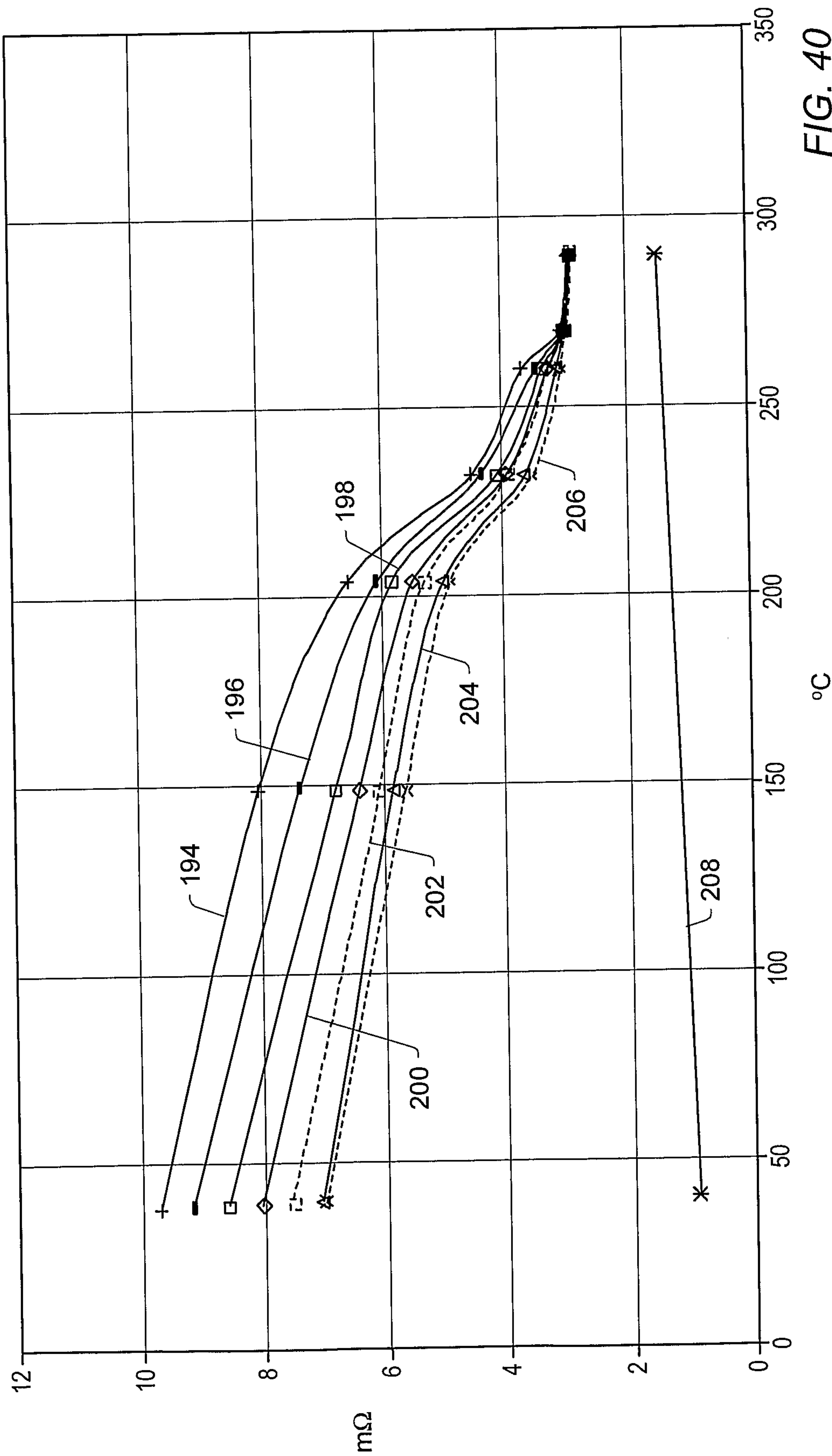

FIG. 40

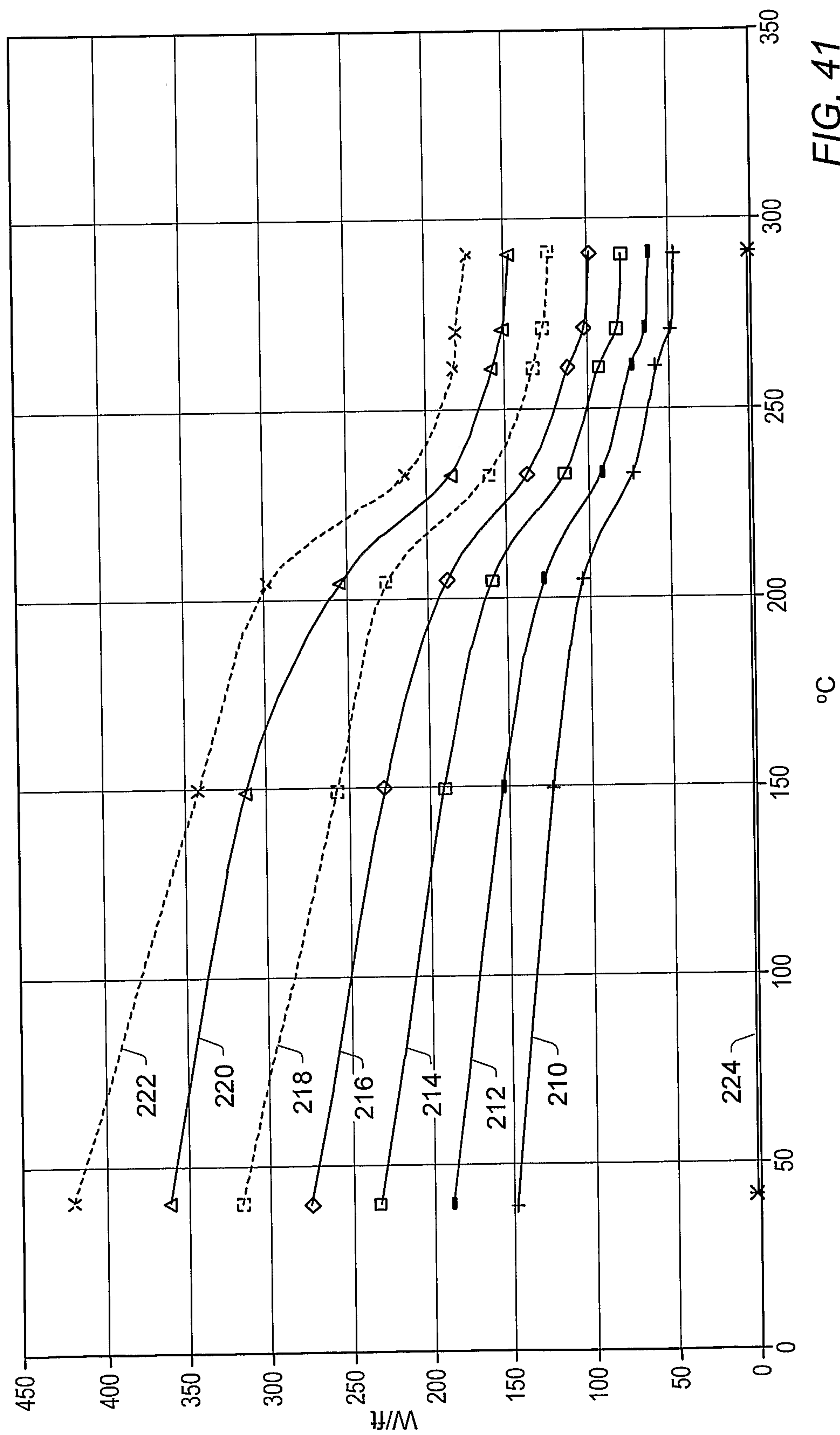

FIG. 41

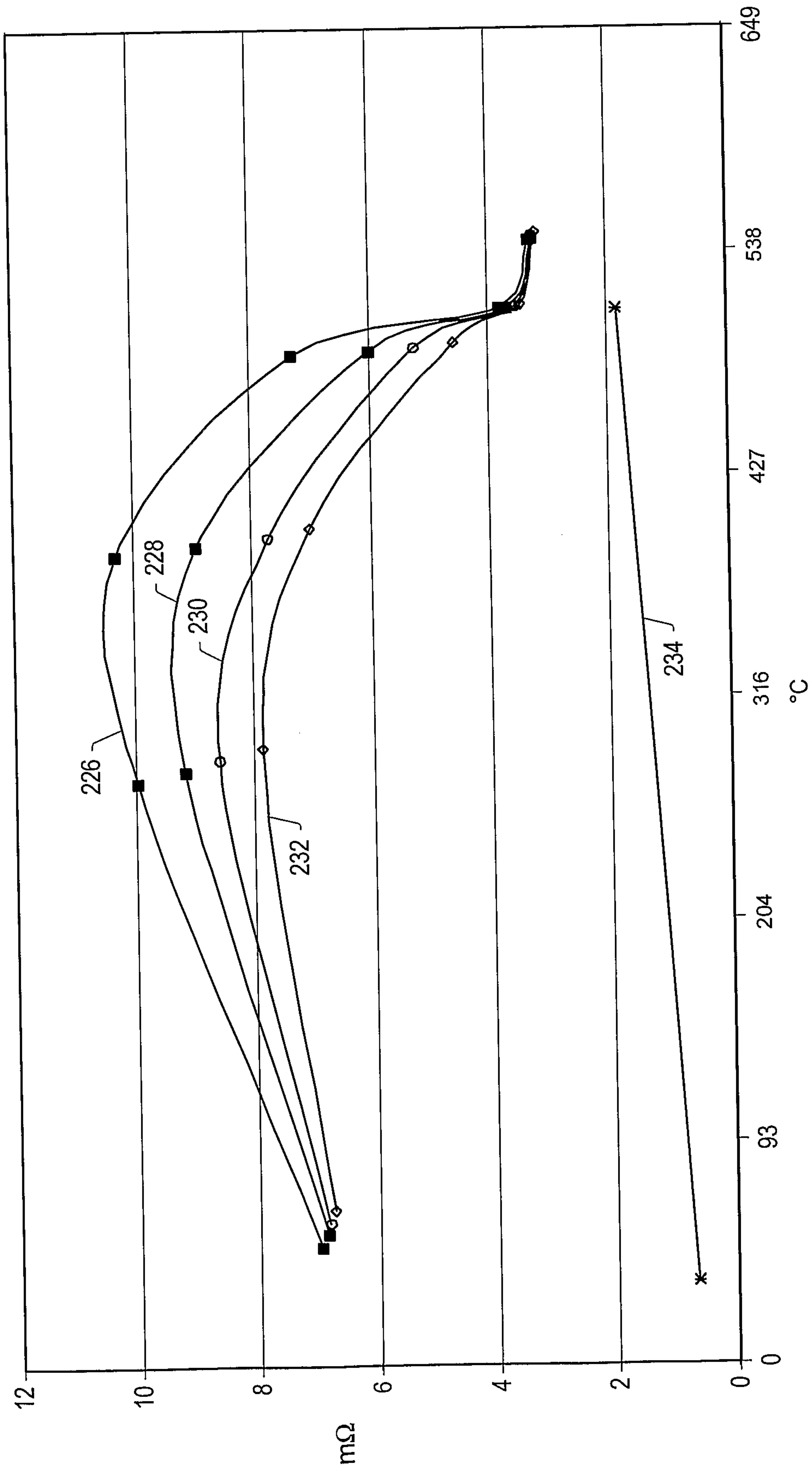

FIG. 42

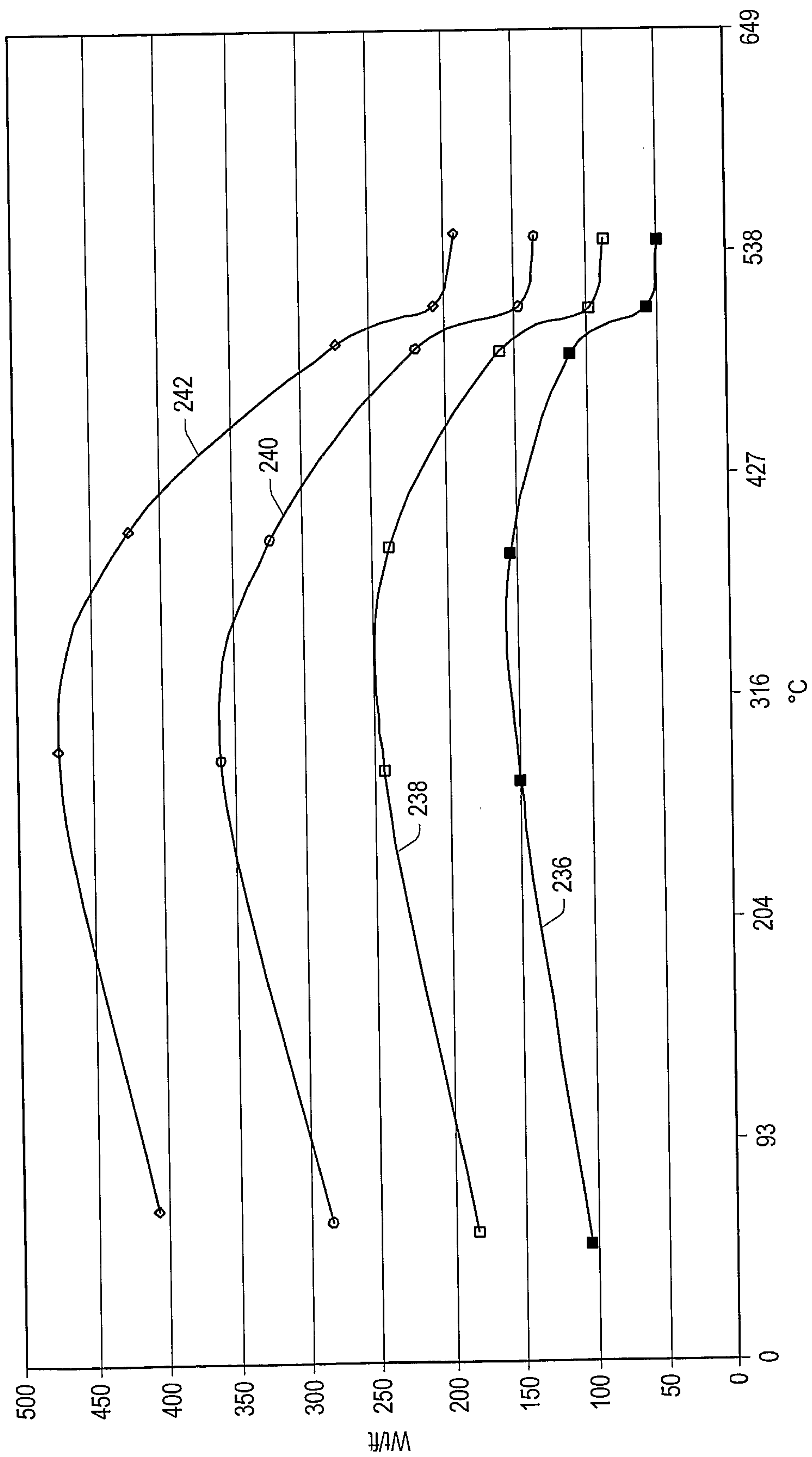

FIG. 43

