



- (51) **International Patent Classification:**  
A47J 37/06 (2006.01)
- (21) **International Application Number:**  
PCT/EP2017/069556
- (22) **International Filing Date:**  
02 August 2017 (02.08.2017)
- (25) **Filing Language:** English
- (26) **Publication Language:** English
- (30) **Priority Data:**  
102016000082900 05 August 2016 (05.08.2016) IT
- (71) **Applicant:** DE' LONGHI APPLIANCES S.R.L. CON UNICO SOCIO [IT/IT]; Via L. Seitz, 47, 31100 TREVISO (IT).
- (72) **Inventors:** DE' LONGHI, Giuseppe; Vicolo Rovero, 1, 31100 TREVISO (IT). TREVISAN, Gianpaolo; Via Pin-
- demonte, 3/A, 37036 SAN MARTINO BUON ALBERGO (IT).
- (74) **Agent:** PETRAZ, Gilberto Luigi et al.; GLP SRL, Viale Europa Unita, 171, 33100 UDINE (IT).
- (81) **Designated States** (unless otherwise indicated, for every kind of national protection available): AE, AG, AL, AM, AO, AT, AU, AZ, BA, BB, BG, BH, BN, BR, BW, BY, BZ, CA, CH, CL, CN, CO, CR, CU, CZ, DE, DJ, DK, DM, DO, DZ, EC, EE, EG, ES, FI, GB, GD, GE, GH, GM, GT, HN, HR, HU, ID, IL, IN, IR, IS, JO, JP, KE, KG, KH, KN, KP, KR, KW, KZ, LA, LC, LK, LR, LS, LU, LY, MA, MD, ME, MG, MK, MN, MW, MX, MY, MZ, NA, NG, NI, NO, NZ, OM, PA, PE, PG, PH, PL, PT, QA, RO, RS, RU, RW, SA, SC, SD, SE, SG, SK, SL, SM, ST, SV, SY, TH, TJ, TM, TN, TR, TT, TZ, UA, UG, US, UZ, VC, VN, ZA, ZM, ZW.
- (84) **Designated States** (unless otherwise indicated, for every kind of regional protection available): ARIPO (BW, GH, GM, KE, LR, LS, MW, MZ, NA, RW, SD, SL, ST, SZ, TZ,

(54) **Title:** AUTONOMOUS APPARATUS FOR COOKING FOOD, AND CORRESPONDING METHOD

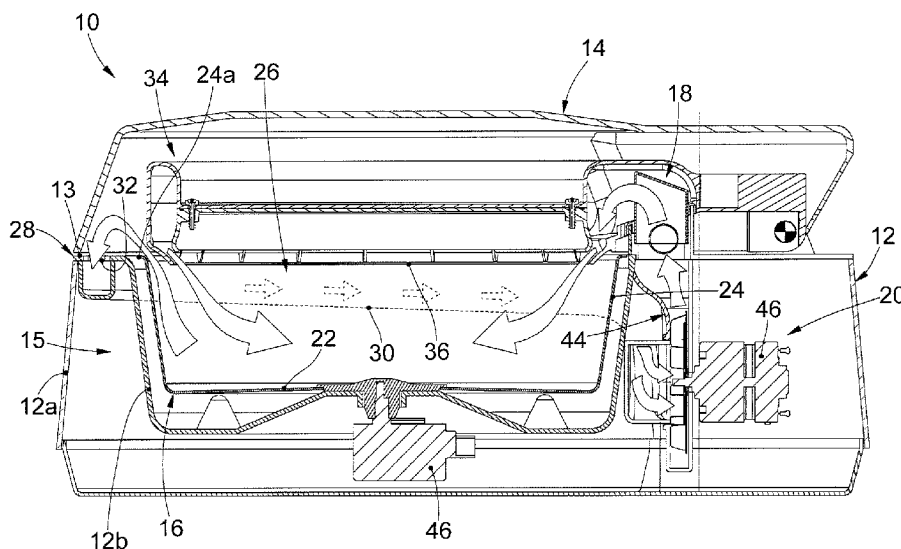

fig. 3

(57) **Abstract:** Autonomous apparatus for cooking food comprising a support body (12), an openable lid (14), an internal container (16) which can be extracted/inserted with respect to said support body (12) and open at the top, at least one heating device (18) and at least one element (20) to generate a flow of air toward the inside of said container. Said at least one air flow generator element (20) is connected to a return exit (28) cooperating, when said lid (14) is in the closed position on said container (16), with a peripheral edge of said container (16) to remove said flow of air from said container (16) and to channel it toward said at least one heating device (18) by means of an annular pipe (30).



UG, ZM, ZW), Eurasian (AM, AZ, BY, KG, KZ, RU, TJ, TM), European (AL, AT, BE, BG, CH, CY, CZ, DE, DK, EE, ES, FI, FR, GB, GR, HR, HU, IE, IS, IT, LT, LU, LV, MC, MK, MT, NL, NO, PL, PT, RO, RS, SE, SI, SK, SM, TR), OAPI (BF, BJ, CF, CG, CI, CM, GA, GN, GQ, GW, KM, ML, MR, NE, SN, TD, TG).

**Published:**

— with international search report (Art. 21(3))

“AUTONOMOUS APPARATUS FOR COOKING FOOD, AND  
CORRESPONDING METHOD”

\* \* \* \* \*

FIELD OF THE INVENTION

5 The present invention concerns an autonomous apparatus for cooking food, comprising a support body, a lid and a container for the food that can be removed/inserted with respect to the support body.

The autonomous apparatus also comprises at least one heating device and at least one element able to generate a flow of air to the food.

10 BACKGROUND OF THE INVENTION

In the domestic environment, autonomous apparatuses for cooking food are known, comprising a support body and an internal container, selectively extractable and open at the top.

15 The apparatus is also provided with a lid, possibly part of or associable with the support body, which can be closed on the internal container to create a cooking compartment having a controlled atmosphere suitable for the cooking to be carried out.

20 Furthermore, at least one heat energy producing device is normally present, disposed at the bottom and/or top of the internal container, which usually cooperates with one or more elements suitable to generate a flow of heated air to the container, so as to provide the desired contribution of heat energy to the food.

25 For the purposes of obtaining a proper and homogenous cooking of the food, it is important that the flow of hot air takes a certain path; from a sending aperture, the flow of air must be distributed uniformly inside the container and between the food and then be removed through a return exit.

However, it often happens that, due to the conformation of the return exit and/or due to the position where it is installed, the flow of air is not taken to follow a path that passes correctly and uniformly through the food, and hence the heat inside the cooking compartment is not distributed homogeneously.

30 Furthermore, the return of the flow of air to the heating device in certain cases is difficult, because it is hampered by barriers and/or screens present along the path, which cause losses in the flow rate, despite the presence of elements to generate the flow of air.

Document US 2008/0163764 describes an autonomous apparatus for cooking food comprising a support body, a lid hinged to the support body and selectively openable, an internal container that can be removed from/inserted into the support body and is open at the top to accommodate the food, a heating element and an element to generate a flow of air toward the inside of the container. The autonomous apparatus is configured to channel the flow of air from the container to the heating device by means of a pipe made between an internal wall of the support body, conformed to accommodate the container, and the wall of the container. The document also describes a deflector screen to channel the air from the container toward the heating device. The screen is disposed between the wall of the container and the internal wall of the support body, or is defined by the external wall of the container. Consequently there are no annular pipes that are physically connected to the generator element, to direct the flow of air toward the heating device in an orderly and compartmentalized manner.

Document EP 3 009 054 describes an autonomous cooking apparatus that, like the one described in document US 2008/0163764, includes an exit aperture, lateral and upper with respect to the container, of the flow of air entering a cooking chamber. The flow of air exits from the cooking chamber through an air channel defined between the lower support body and the internal wall of the support body.

One purpose of the present invention is to obtain an autonomous apparatus for cooking food that allows to distribute the heat homogeneously inside the cooking compartment so as to make the heat contribution uniform to all the foods contained in the compartment itself.

Another purpose of the present invention is to obtain an autonomous apparatus for cooking food that optimizes the heat exchange, determining energy savings and allowing the optimum cooking of the food.

The Applicant has devised, tested and embodied the present invention to overcome the shortcomings of the state of the art and to obtain these and other purposes and advantages.

#### SUMMARY OF THE INVENTION

The present invention is set forth and characterized in the independent claims, while the dependent claims describe other characteristics of the invention or

variants to the main inventive idea.

In accordance with the above purposes, the present invention concerns an autonomous apparatus for cooking food comprising a support body, a lid, an internal container open at the top and which can be extracted/inserted with respect to said support body, at least one heating device and at least one element to generate a flow of air toward the inside of said container.

The air flow generator element is connected to a return exit cooperating, when the lid is in the closed position on the container, with a peripheral edge of the container to remove the flow of air from the container and to channel it toward the heating device by means of an annular pipe.

According to one aspect of the present invention, the annular pipe has two ends, symmetrically connected to the at least one air flow generator element.

The annular pipe that picks up the air is therefore disposed around and outside the mouth of the food container, so that the air taken is distributed uniformly around the upper edge of the container.

In particular, the flow of air exiting from the container is sucked from the return exit, determining a closed circuit to recirculate the flow of air.

The present invention also concerns a method to return a flow of heat conditioned air inside an autonomous apparatus for cooking food, which uses the return aperture made on an upper edge of the support body.

#### BRIEF DESCRIPTION OF THE DRAWINGS

These and other characteristics of the present invention will become apparent from the following description of some embodiments, given as a non-restrictive example with reference to the attached drawings wherein:

- fig. 1 is a perspective view of an autonomous apparatus for cooking food;
- fig. 2 is a section view of the autonomous apparatus in fig. 1;
- fig. 3 is another section view of the autonomous apparatus in fig. 1;
- fig. 4 is a detail of a section view of the autonomous apparatus in fig. 1;
- fig. 5 is section view of the autonomous apparatus in one embodiment.

To facilitate comprehension, the same reference numbers have been used, where possible, to identify identical common elements in the drawings. It is understood that elements and characteristics of one embodiment can conveniently be incorporated into other embodiments without further clarifications.

## DETAILED DESCRIPTION OF SOME EMBODIMENTS

Embodiments described here in figs. 1-5 refer to an autonomous apparatus 10 for cooking foods, able to perform various cooking modes, such as stewing, brazing, boiling, roasting, frying, simple heating, sautéing, browning, slow cooking, or quick cooking in general.

The autonomous apparatus 10 comprises a support body 12, with which is associated an openable lid 14, an extractable/insertable internal container 16, open at the top and defining a cooking compartment 26 for food, at least one heating device 18 and at least one air flow generator element 20.

10 The support body 12 has an external wall 12a and an internal wall 12b, adjacent during use to the container 16. Between the external wall 12a and the internal wall 12b there is an interspace 15 which can function as a technical compartment.

15 The support body 12 has an upper edge 13 which cooperates at least partly with a lower edge of the lid 14 when the latter is closed to cover the container 16.

The presence of the lid 14 is functional to create a controlled environment and conditions necessary for cooking the food.

The lid 14 can be made of the same material as the support body 12, or of a different material.

20 Advantageously, at least the lid 14 can be made of at least partly transparent material, to allow the user to view and thus control the cooking.

For example, the lid 14 can be made of a polymer or glass material.

25 The container 16 is defined by a base wall 22, which in this non-restrictive case is substantially circular, and by a lateral wall 24 connected to the base wall 22 and having a peripheral edge 24a.

The container 16 is configured to allow the association of one or more grips to allow to handle the container 16.

The base wall 22 can have a surface made with a plurality of configurations, for example conical, or hump-backed, more or less accentuated.

30 In a preferred embodiment, to which reference will be made hereafter, the base wall 22 has a substantially flat configuration.

The container 16 is open at the top to introduce food inside it and to allow the circulation of the flow of air from the heating device 18 to the food.

According to one aspect of the present invention, the generator element 20 is connected to a return exit 28 which, when the lid is in the closed position on the container, cooperates with the peripheral edge 24a of the container 16.

5 The return exit 28 is configured to extract the flow of air immediately exiting from the container 16 and to channel it to the heating device 18 by means of an annular pipe 30.

According to one aspect of the present invention, the annular pipe 30 has ends that are symmetrically connected to the generator element 20.

10 In this way, advantageously, the air flow is conveyed and divided symmetrically along the annular pipe 30 to converge toward the generator element 20.

According to one embodiment, shown by way of example in figs. 2 and 3, the annular pipe 30 is installed between the support body 12 and the container 16.

For example, the annular pipe 30 is installed in the interspace 15.

15 Advantageously, the annular pipe 30 encloses a space and channels the flow of air in a univocal manner, determining its closed circuit path.

In this particular embodiment, the annular pipe 30 has a plurality of slits 32 disposed along the development of the annular pipe 30 and disposed in correspondence with the upper edge 13 of the support body 12.

20 The annular pipe 30 develops for the entire circumference of the cooking apparatus 10 and has at least one end connected to the generator element 20.

The lid 14 advantageously has a hollow internal surface in correspondence with the plurality of slits 32.

25 According to one formulation of the present invention, the generator element 20 cooperates with a sending aperture 34 to send the flow of air, provided on the lid 14.

30 According to one embodiment of the present invention, which is shown by way of example in figs. 1-3 and 5, the sending aperture 34 can have a substantially hollow toroidal shape which cooperates, when the lid 14 is closed on the container 16, with the peripheral edge 24a of the container 16.

The sending aperture 34 can have a circumferential slit 36 that allows the flow of air circulating in the toroidal cavity to escape from it, to be directed, when the lid 14 is at least partly closed, to the container 16.

In the case where there is the sending aperture 34 with a toroidal or substantially circular development, it develops on a circumference with a smaller diameter than the peripheral edge 24a of the container 16, to allow to discharge the flow of air from the container 16 to the return exit 28.

5 In this way, the sending aperture 34 does not abut against the circumferential edge 24a, thus creating a gap that allows to discharge the flow of air from the container 16 to the sending exit 28.

According to another embodiment, the sending aperture 34 can have a limited development and in proximity to the heating device 18.

10 The autonomous apparatus 10 comprises a recirculation pipe 44 which determines the connection between the generator element 20 and the heating device 18, in practice connecting the return exit 28 to the sending aperture 34.

According to embodiments described here, the recirculating pipe 44 can be configured to determine the continuation of the annular pipe 30 (fig. 4).

15 The generator element 20 can be installed at any point whatsoever inside the interspace 15 provided that it allows to recirculate the flow of air.

The generator element 20 can be, for example, an axial, centrifugal or mixed axial/centrifugal fan, made to rotate by a drive member 46.

20 According to one embodiment, shown by way of example in fig. 5, the autonomous apparatus 10 can comprise an additional auxiliary heating device 47, or alternative to the heating device 18, for example installed in proximity to the base wall 22.

25 According to embodiments described here, the container 16 can be rotated around an axis of rotation, preferably in relation to the center of the base wall 22, by means of an additional drive member 46.

According to other embodiments described here, the autonomous apparatus 10 can comprise a mixing device 48 which is provided with at least one mixing blade, rotating with respect to the container 16 (fig. 5).

30 It is clear that modifications and/or additions of parts may be made to the autonomous apparatus 10 and corresponding method as described heretofore, without departing from the field and scope of the present invention.

It is also clear that, although the present invention has been described with reference to some specific examples, a person of skill in the art shall certainly be

able to achieve many other equivalent forms of autonomous apparatus 10 and corresponding method, having the characteristics as set forth in the claims and hence all coming within the field of protection defined thereby.

## CLAIMS

1. Autonomous apparatus for cooking food comprising a support body (12), an openable lid (14), an internal container (16) which can be extracted/inserted with respect to said support body (12) and open at the top, at least one heating device  
5 (18) and at least one element (20) to generate a flow of air toward the inside of said container (16), said at least one air flow generator element (20) being connected to a return exit (28) cooperating, when said lid (14) is in the closed position on said container (16), with a peripheral edge (24a) of said container  
10 (16) to remove said flow of air from said container (16) and to channel it toward said at least one heating device (18) by means of an annular pipe (30), **characterized in that** said annular pipe (30) has two ends symmetrically connected to said at least one air flow generator element (20).
2. Autonomous apparatus as in claim 1, **characterized in that** said annular pipe (30) has a plurality of fissures (32) disposed along it and in correspondence with  
15 an upper edge (13) of said support body (12).
3. Autonomous apparatus as in claim 1 or 2, **characterized in that** it comprises a sending aperture (34) with a substantially hollow toroidal shape cooperating with a peripheral edge (24a) of the container (16).
4. Autonomous apparatus as in claim 3, **characterized in that** said sending  
20 aperture (34) has a circumferential slit (36) configured to allow said flow of air to exit from the cavity of said sending aperture (34) and to position itself with said lid (14) at least partly closed in said container (16).
5. Autonomous apparatus as in claim 3 or 4, **characterized in that** said sending  
25 aperture (34) develops on a lower circumference with respect to said circumferential edge (24a) to determine the discharge of said flow of air from said container (16) toward said return exit (28).
6. Autonomous apparatus as in any claim hereinbefore, **characterized in that** said container (16) is rotatable around an axis of rotation by means of a drive member (46).
- 30 7. Autonomous apparatus as in any claim hereinbefore, **characterized in that** it comprises a mixing device (48) provided with at least one mixing blade rotating with respect to said container (16).
8. Method to return a flow of air inside an autonomous apparatus (10) for

cooking food comprising a support body (12), an openable lid (14), an internal container (16) which can be extracted/inserted with respect to said support body (12) and open at the top, at least one heating device (18) and at least one element (20) to generate a flow of air toward the inside of said container (16),

5 **characterized in that** it provides to:

- heat a flow of air by means of said at least one heating device (18);
- remove said flow of used air from said container (16) through a return exit (28) cooperating, when said lid (14) is in the closed position on said container (16), with a peripheral edge (24a) of said container (16);

10 - channel said flow of air toward said at least one heating device (18) by means of an annular pipe (30) in order to define a closed circuit travel of said flow of air, wherein said the annular pipe (30) has two ends, symmetrically connected to said at least one air flow generator element (20).

1/3

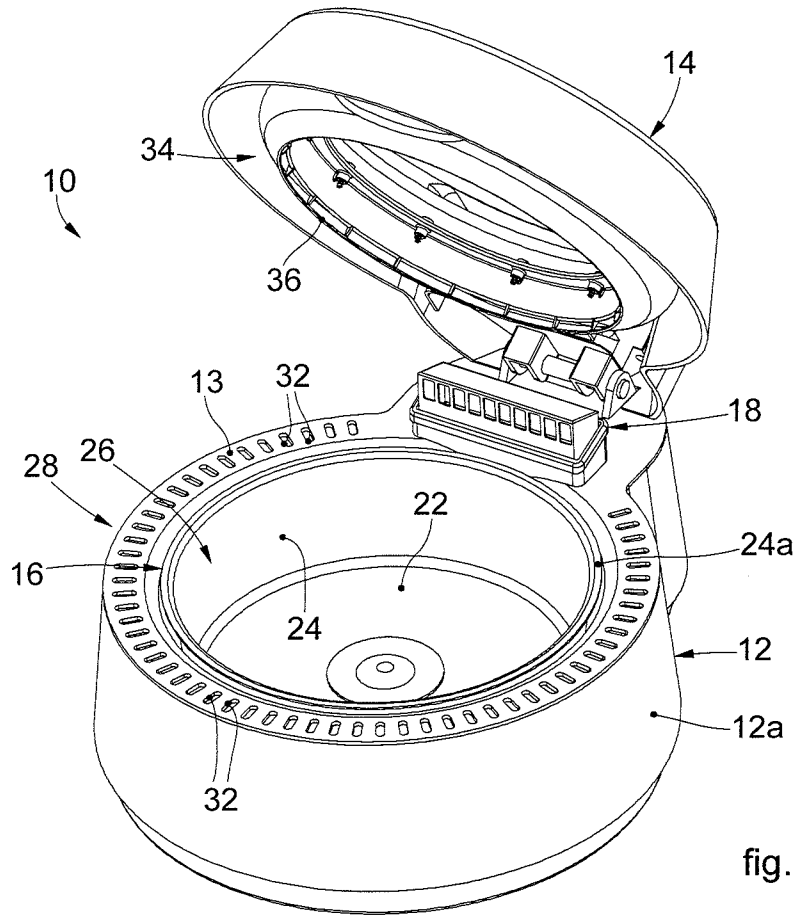

fig. 1

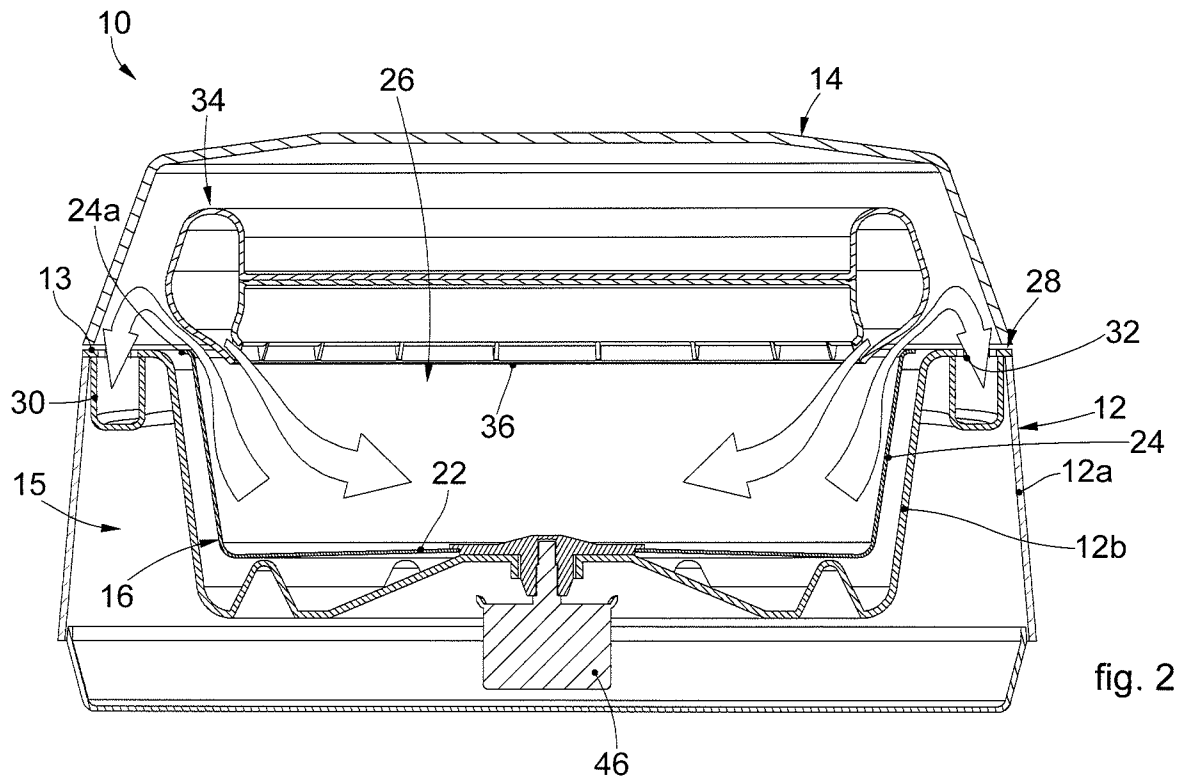

fig. 2

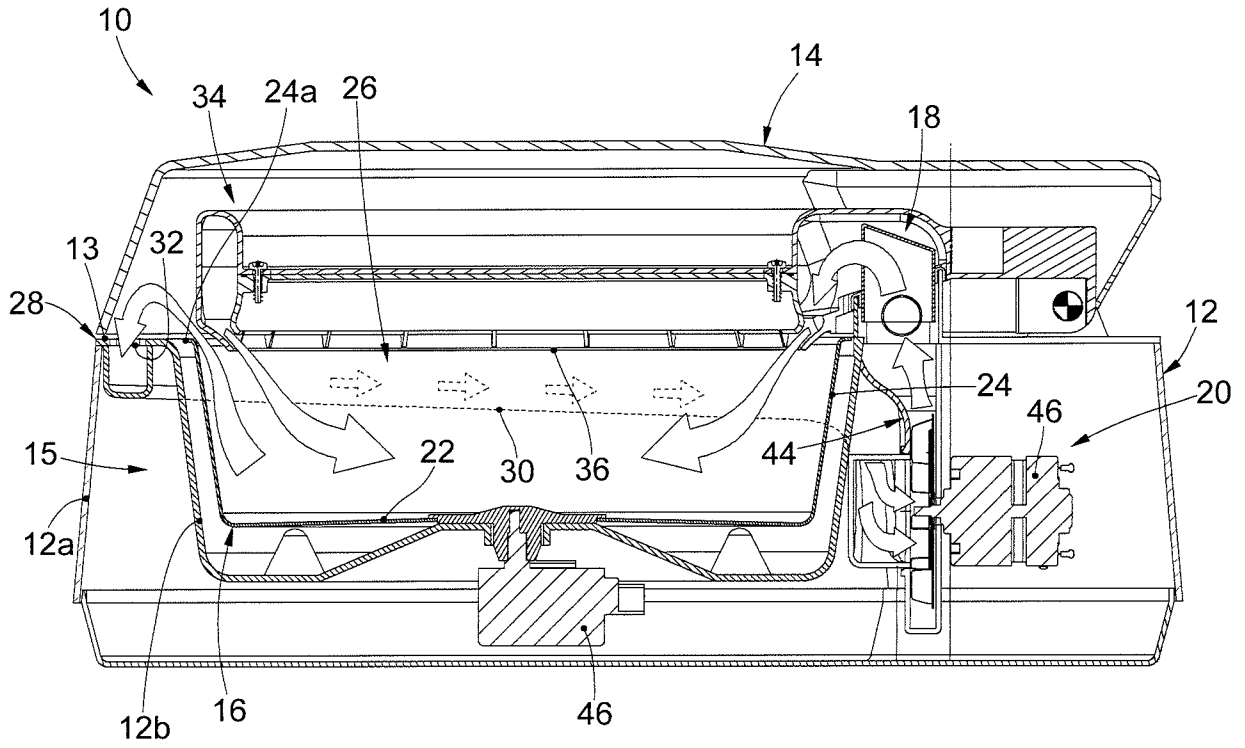

fig. 3

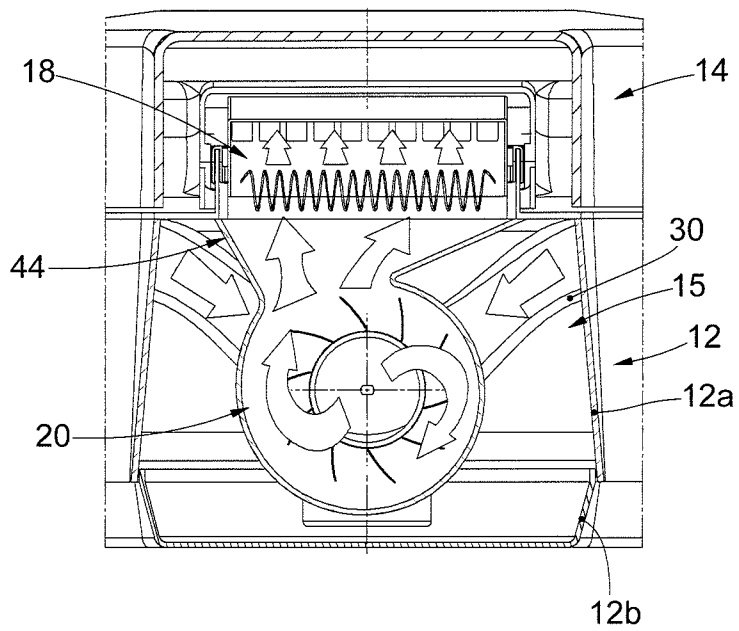

fig. 4



INTERNATIONAL SEARCH REPORT

International application No  
PCT/EP2017/069556

A. CLASSIFICATION OF SUBJECT MATTER  
INV. A47J37/06  
ADD.  
According to International Patent Classification (IPC) or to both national classification and IPC

B. FIELDS SEARCHED  
Minimum documentation searched (classification system followed by classification symbols)  
A47J  
Documentation searched other than minimum documentation to the extent that such documents are included in the fields searched

Electronic data base consulted during the international search (name of data base and, where practicable, search terms used)  
EPO-Internal, WPI Data

C. DOCUMENTS CONSIDERED TO BE RELEVANT

Category*	Citation of document, with indication, where appropriate, of the relevant passages	Relevant to claim No.
A	US 2008/163764 A1 (PAYEN JEAN-MARC [FR] ET AL) 10 July 2008 (2008-07-10) cited in the application paragraphs [0043], [0047], [0049] - [0052], [0056] - [0062], [0065], [0066], [0069], [0070], [0072] - [0075], [0085] paragraphs [0088], [0090], [0093], [0107], [0117] - [0124] figures -----	1,3-8
A	EP 3 009 054 A1 (MAI TIANHONG [CN]) 20 April 2016 (2016-04-20) cited in the application paragraphs [0020], [0024], [0025] - [0028], [0031]; figures 1, 3 ----- -/--	1,3,6,8

Further documents are listed in the continuation of Box C.

See patent family annex.

\* Special categories of cited documents :

- "A" document defining the general state of the art which is not considered to be of particular relevance
- "E" earlier application or patent but published on or after the international filing date
- "L" document which may throw doubts on priority claim(s) or which is cited to establish the publication date of another citation or other special reason (as specified)
- "O" document referring to an oral disclosure, use, exhibition or other means
- "P" document published prior to the international filing date but later than the priority date claimed

- "T" later document published after the international filing date or priority date and not in conflict with the application but cited to understand the principle or theory underlying the invention
- "X" document of particular relevance; the claimed invention cannot be considered novel or cannot be considered to involve an inventive step when the document is taken alone
- "Y" document of particular relevance; the claimed invention cannot be considered to involve an inventive step when the document is combined with one or more other such documents, such combination being obvious to a person skilled in the art
- "&" document member of the same patent family

Date of the actual completion of the international search 19 October 2017	Date of mailing of the international search report 02/11/2017
--	--

Name and mailing address of the ISA/ European Patent Office, P.B. 5818 Patentlaan 2 NL - 2280 HV Rijswijk Tel. (+31-70) 340-2040, Fax: (+31-70) 340-3016	Authorized officer Novelli, Bruno
--	--------------------------------------

## INTERNATIONAL SEARCH REPORT

International application No  
PCT/EP2017/069556

C(Continuation). DOCUMENTS CONSIDERED TO BE RELEVANT		
Category*	Citation of document, with indication, where appropriate, of the relevant passages	Relevant to claim No.
A	US 2015/201806 A1 (YOSHIDOME AKIHIRO [JP]) 23 July 2015 (2015-07-23) paragraphs [0028] - [0032], [0035] - [0037], [0039] - [0041]; figure 1 -----	1,8

# INTERNATIONAL SEARCH REPORT

Information on patent family members

International application No

PCT/EP2017/069556

Patent document cited in search report	Publication date	Patent family member(s)	Publication date	
US 2008163764	A1	10-07-2008	AT 473666 T	15-07-2010
			CA 2569972 A1	05-01-2006
			CN 1964653 A	16-05-2007
			DE 202005021835 U1	17-06-2010
			DK 1768535 T3	08-11-2010
			EP 1768535 A2	04-04-2007
			PT 1768535 E	21-10-2010
			US 2008163764 A1	10-07-2008
			WO 2006000700 A2	05-01-2006
EP 3009054	A1	20-04-2016	CN 103271632 A	04-09-2013
			EP 3009054 A1	20-04-2016
			WO 2014198199 A1	18-12-2014
US 2015201806	A1	23-07-2015	CN 104662369 A	27-05-2015
			JP 6017941 B2	02-11-2016
			JP 2014109400 A	12-06-2014
			US 2015201806 A1	23-07-2015
			WO 2014084335 A1	05-06-2014