

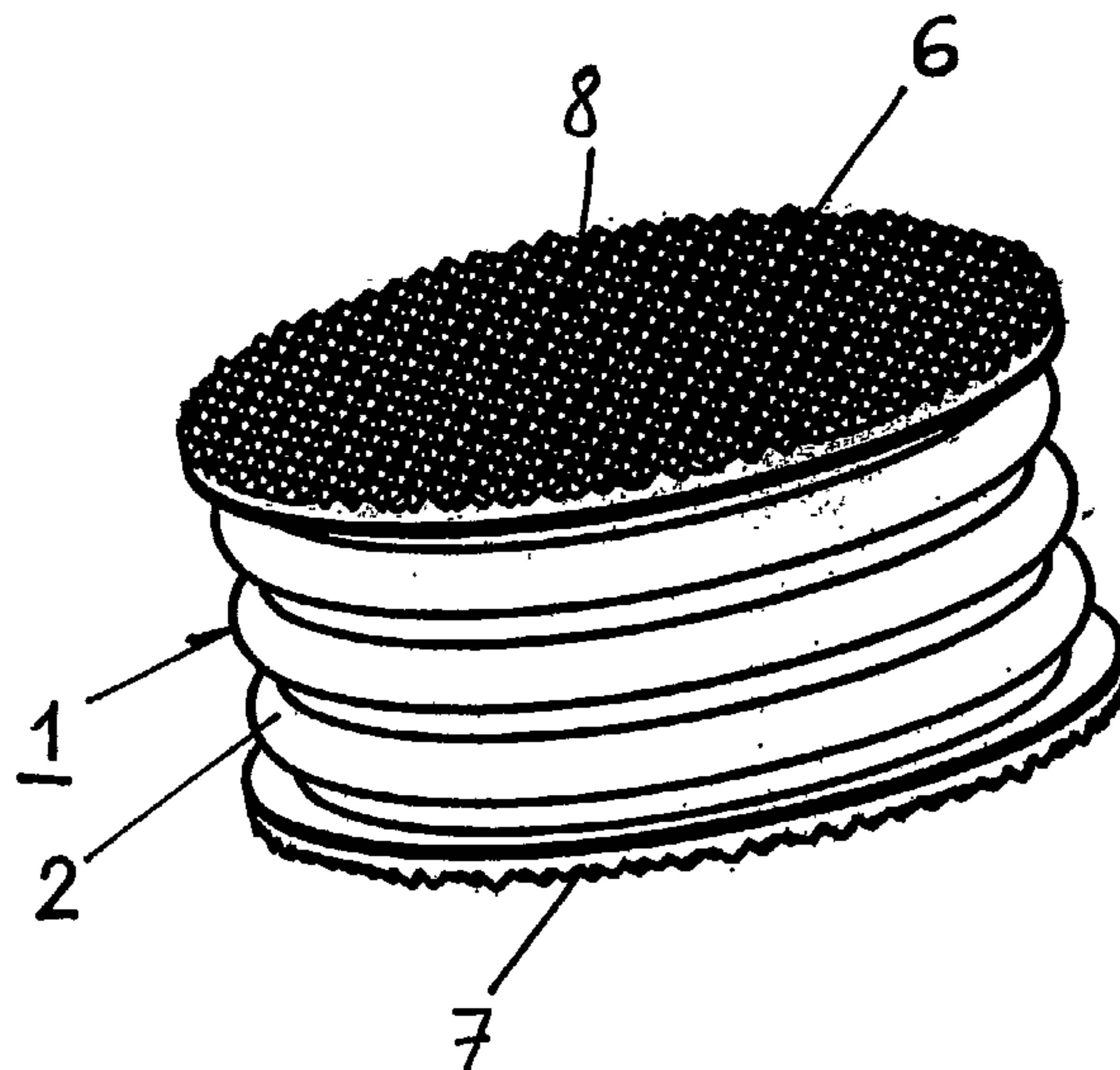

(86) Date de dépôt PCT/PCT Filing Date: 2002/10/28
 (87) Date publication PCT/PCT Publication Date: 2004/05/06
 (85) Entrée phase nationale/National Entry: 2005/04/12
 (86) N° demande PCT/PCT Application No.: CH 2002/000582
 (87) N° publication PCT/PCT Publication No.: 2004/037131

(51) Cl.Int.⁷/Int.Cl.⁷ A61F 2/44
 (71) Demandeur/Applicant:
 MATHYS MEDIZINALTECHNIK AG, CH
 (72) Inventeurs/Inventors:
 STUDER, ARMIN, CH;
 TRACHSEL, JASON, CH;
 WYMANN, MARTIN, CH
 (74) Agent: MARKS & CLERK

(54) Titre : PROTHESE DISCALE OU VERTEBRE ARTIFICIELLE
 (54) Title: INTERVERTEBRAL DISK PROSTHESIS OR ARTIFICIAL VERTEBRA



(57) **Abrégé/Abstract:**

Disclosed is an intervertebral disk prosthesis comprising an essentially hollow cylindrical base element (1) which is provided with a casing (2) that is embodied as a bellows, a top end (3), a bottom end (4), and a central longitudinal axis (5), an upper apposition plate (6) which is disposed perpendicular to the longitudinal axis (5) at the top end (3) of the base element (1) and rests on the base plate of a vertebra, and a lower apposition plate (7) that is arranged perpendicular to the longitudinal axis (5) at the bottom end (4) of the base element (1) and leans on the cover plate of a vertebra. The casing (2) that is embodied as a bellows is configured as a spring element having a defined spring rate. Said structure largely approaches the function and purpose of a natural intervertebral disk.

(12) NACH DEM VERTRAG ÜBER DIE INTERNATIONALE ZUSAMMENARBEIT AUF DEM GEBIET DES
PATENTWESENS (PCT) VERÖFFENTLICHTE INTERNATIONALE ANMELDUNG(19) Weltorganisation für geistiges Eigentum
Internationales Büro(43) Internationales Veröffentlichungsdatum
6. Mai 2004 (06.05.2004)

PCT

(10) Internationale Veröffentlichungsnummer
WO 2004/037131 A1(51) Internationale Patentklassifikation⁷: A61F 2/44

(21) Internationales Aktenzeichen: PCT/CH2002/000582

(22) Internationales Anmeldedatum:
28. Oktober 2002 (28.10.2002)

(25) Einreichungssprache: Deutsch

(26) Veröffentlichungssprache: Deutsch

(71) Anmelder (für alle Bestimmungsstaaten mit Ausnahme von
US): MATHYS MEDIZINALTECHNIK AG [CH/CH];
Güterstrasse 5, CH-2544 Bettlach (CH).

(72) Erfinder; und

(75) Erfinder/Anmelder (nur für US): STUDER, Armin
[CH/CH]; Bahnhofstrasse 34, CH-6312 Steinhausen
(CH). TRACHSEL, Jason [CH/CH]; Schürlistrasse 12,
CH-2563 Ipsach (CH). WYMANN, Martin [CH/CH];
Rosenweg 13, CH_3097 Liebefeld (CH).(74) Anwalt: LUSUARDI, Werther; Dr. Lusuardi AG,
Kreuzbühlstrasse 8, CH-8008 Zürich (CH).(81) Bestimmungsstaaten (national): AE, AG, AL, AM, AT,
AU, AZ, BA, BB, BG, BR, BY, BZ, CA, CH, CN, CO, CR,
CU, CZ, DE, DK, DM, DZ, EC, EE, ES, FI, GB, GD, GE,
GH, GM, HR, HU, ID, IL, IN, IS, JP, KE, KG, KP, KR, KZ,
LC, LK, LR, LS, LT, LU, LV, MA, MD, MG, MK, MN,
MW, MX, MZ, NO, NZ, PL, PT, RO, RU, SD, SE, SG, SI,
SK, SL, TJ, TM, TR, TT, TZ, UA, UG, US, UZ, VN, YU,
ZA, ZW.(84) Bestimmungsstaaten (regional): ARIPO-Patent (GH,
GM, KE, LS, MW, MZ, SD, SL, SZ, TZ, UG, ZM, ZW),
eurasisches Patent (AM, AZ, BY, KG, KZ, MD, RU, TJ,
TM), europäisches Patent (AT, BE, BG, CH, CY, CZ, DE,
DK, EE, ES, FI, FR, GB, GR, IE, IT, LU, MC, NL, PT,
SE, SK, TR), OAPI-Patent (BF, BJ, CF, CG, CI, CM, GA,
GN, GQ, GW, ML, MR, NE, SN, TD, TG).

Veröffentlicht:

— mit internationalem Recherchenbericht

Zur Erklärung der Zweibuchstaben-Codes und der anderen Ab-
kürzungen wird auf die Erklärungen ("Guidance Notes on Co-
des and Abbreviations") am Anfang jeder regulären Ausgabe der
PCT-Gazette verwiesen.

(54) Title: INTERVERTEBRAL DISK PROSTHESIS OR ARTIFICIAL VERTEBRA

(54) Bezeichnung: BANDSCHEIBENPROTHESE ODER KÜNSTLICHER WIRBELKÖRPER

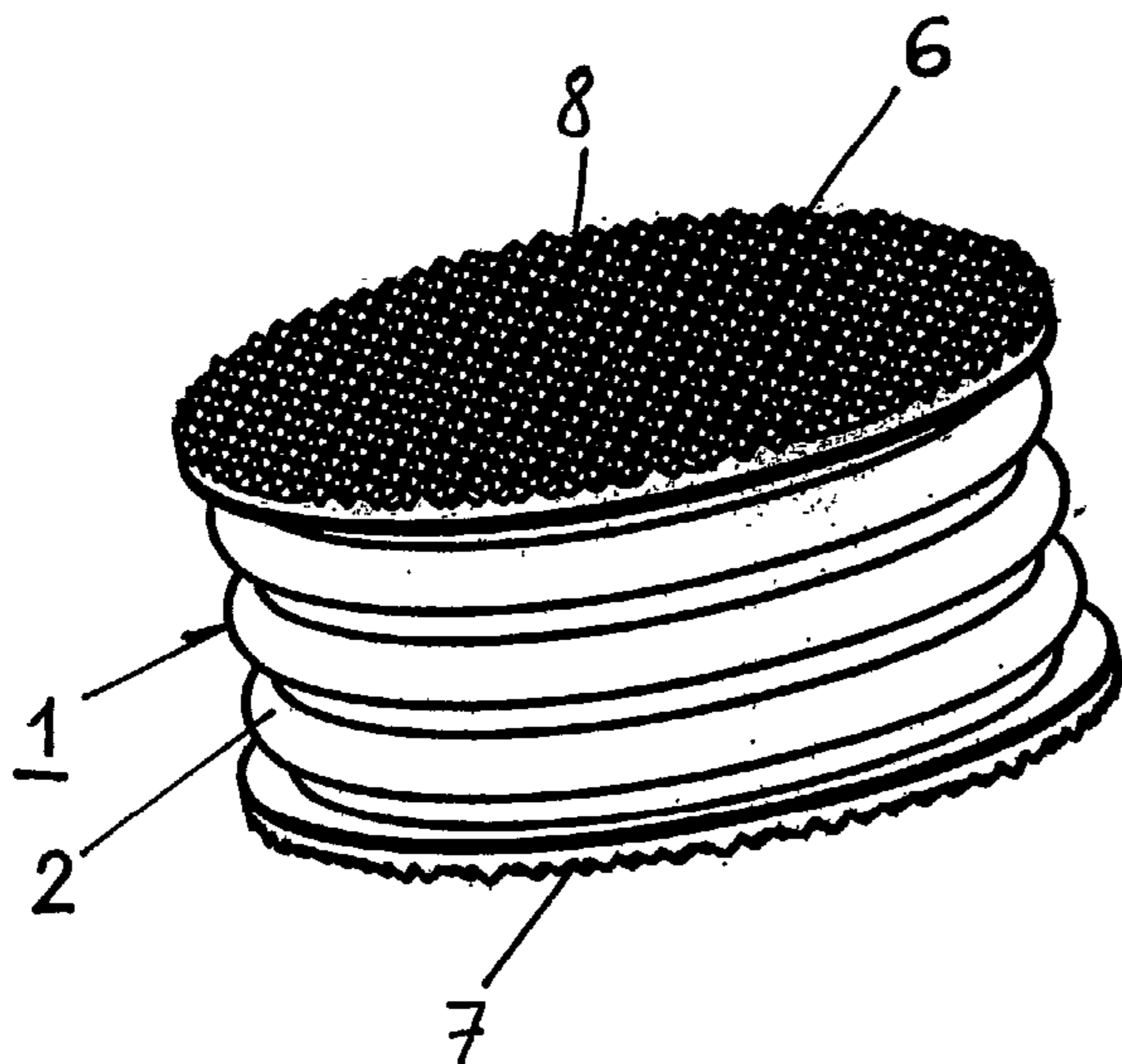
(57) Abstract: Disclosed is an intervertebral disk prosthesis com-
prising an essentially hollow cylindrical base element (1) which is
provided with a casing (2) that is embodied as a bellows, a top end
(3), a bottom end (4), and a central longitudinal axis (5), an upper
apposition plate (6) which is disposed perpendicular to the longitu-
dinal axis (5) at the top end (3) of the base element (1) and rests on
the base plate of a vertebra, and a lower apposition plate (7) that is
arranged perpendicular to the longitudinal axis (5) at the bottom end
(4) of the base element (1) and leans on the cover plate of a verte-
bra. The casing (2) that is embodied as a bellows is configured as a
spring element having a defined spring rate. Said structure largely
approaches the function and purpose of a natural intervertebral disk.(57) Zusammenfassung: Die Bandscheibenprothese besitzt einen
im wesentlichen hohlzylindrischen Grundkörper (1) mit einem als
Faltenbalg ausgebildeten Mantel (2), einem oberen Ende (3), einem
unteren Ende (4) und einer zentralen Längsachse (5), eine am oberen
Ende (3) des Grundkörpers (1) quer zur Längsachse (5) angeordnete,
obere Appositionsplatte (6), welche zur Anlage an die Grundplatte
eines Wirbelkörpers geeignet ist und eine am unteren Ende (4) desGrundkörpers (1) quer zur Längsachse (5) angeordnete, untere Appositionsplatte (7), welche zur Anlage an die Deckplatte eines
Wirbelkörpers geeignet ist. Der als Faltenbalg ausgebildete Mantel (2) ist dabei als Federelement mit einer definierten Federrate
ausgebildet. Dank dieser Bauweise wird eine weitgehende Annäherung an die Funktion und Aufgabe einer natürlichen Band-
scheibe erreicht.

WO 2004/037131 A1

English translation of the amendments under PCT Article 41 of the International Patent Application No. PCT/2002/000582 "Intervertebral disk prosthesis or artificial vertebral body" in the name of Mathys Medizinaltechnik AG

5 Intervertebral disk prosthesis or artificial vertebral body

The invention concerns an intervertebral disk prosthesis or an artificial vertebral body according to the generic part of patent claim 1.

10 From US-A-4 932 975 Main et al. a vertebra prosthesis is known, that comprises an expandable bellows as the basic body. The bellows is made from a flexible material, that allows an expansion of the bellows. However, in the case of this bellows basically one deals with a passive element, that through an opening can be filled with a fluid, while the bellows passively stretches. Thus in the case of this known device it lacks an active
15 elastic element that could flexibly absorb the loads. In addition, a further disadvantage of this known vertebral body prosthesis is that subsequently it has to be filled with a fluid, e.g. a methacrylate (in particular methyl methacrylate MMA), representing considerable risks.

From WO 00/35383 Dimso, an intervertebral disk prosthesis of the generic type is
20 known. This known intervertebral disk prosthesis comprises a compressible body between two plates, said body is enveloped by a bellows-like jacket. The disadvantage of this known intervertebral disk prosthesis is its low stiffness.

This is where the invention wants to provide remedy. The object of the invention is to produce an intervertebral disk prosthesis or an artificial vertebral body, that has axially
25 dampening components, so that both the translation, rotation and the angulation can be absorbed and transmitted in a defined manner.

The objective set by the invention is achieved with an intervertebral disk prosthesis or an artificial vertebral body, having the features of claim 1.

30 The advantages essentially achieved by the invention are that by virtue of the intervertebral disk prosthesis or the artificial vertebral body the function and the task of an intervertebral disk or of a natural vertebral body can be reproduced as close as possible.

35 Further advantageous configurations of the invention are characterised in the dependent claims.

**AMENDED
SHEET**

The comments regarding each embodiment are made in most cases based on an intervertebral disk prosthesis; all embodiments refer, however, also to a possible construction as an artificial vertebral body.

5 The specific spring rate of the spring element should be preferably at least 50 N/mm, preferably at least 100 N/mm. The spring rate is, however, preferably 150 N/mm, preferably at least 400 N/mm. The spring rate should be limited also upwards and be maximum 800 N/mm, preferably maximum 2000 N/mm. The spring rate is typically 600 N/mm.

10

In the case of a load of 1000 N the spring travel of the spring element should be in the range of 1-2 mm, preferably in the range of 1.3-1.7 mm. The spring travel under this load is typically 1.5 mm.

15 According to an embodiment of the invention the spring element is constructed both as a tension spring and as a compression spring.

The number of folds of the jacket, constructed as bellows, is preferably in the range of 3-10, preferably 4-5. This number is advantageous both for the
20 production technology and the desired stretching of the material used.

According to an embodiment of the invention the jacket comprises a plurality of single layers. Thus the stiffness of the bellows can be controlled arbitrarily within certain limits.

25

In the case of a special embodiment the single layers are spaced from one another. By virtue of this construction various bellows can be combined with one another, that can accept various loads, e.g. an external bellows for the angulation, translation, rotation and dampening of a load, for example, 800 N and
30 an internal bellows to accept loads of approx. 2500 N, so that the external bellows will be protected.

In the case of another special embodiment the single layers abut against one another without intermediate layers. Thus the stiffness can be increased.

In the case of another embodiment the jacket comprises a plurality of bellows inserted into one another.

- 5 The jacket may also have slots, that should extend basically parallel to the longitudinal axis. By virtue of this the rotational stiffness of the bellows will be reduced.

10 The rotational stiffness of the jacket should be so chosen, that it would allow 1°-3° rotation of the jacket, preferably 1.5°-2.5°.

When using an axial force of 800 N, the axial stroke of the jacket should be preferably in the range of 1.0-2.5 mm, preferably in the range of 1.30-1.75 mm.

- 15 According to an embodiment of the invention both apposition plates are fastened on the top and bottom ends of the basic body axially firmly but enabling rotation.

20 In the case of an alternative embodiment both apposition plates are axially fastened on the top and bottom ends of the basic body and their rotation about the longitudinal axis is limited, preferably to an angular range of maximum 5°.

In the case of another alternative embodiment both apposition plates are fastened on the top and bottom ends of the basic body axially firmly and unable to rotate.

25

In the case of a special embodiment the rotational stiffness of the jacket constructed as bellows is so chosen, that both apposition plates can be rotated relative one another about the longitudinal axis by an angle of 1°-5°, preferably 2°-3°.

30

In the case of a further embodiment both apposition plates can be tilted from the plane that is orthogonal to the longitudinal axis by an angle of 4°-8°, preferably 5°-7°.

In the case of a particular embodiment of the invention the hollow-cylindrical basic body is filled at least partially with a solid body, preferably a synthetic material, acting as a dampening element. By virtue of this construction the stiffness will be increased and a better absorption of greater shock loads, e.g. 2500 N, will result.

The jacket of the intervertebral disk prosthesis can be made from a metal, e.g. titanium or a metal alloy, preferably based on titanium. The material of the jacket should preferably have a minimum stretch limit of 30 %, preferably a minimum of 38 %. The jacket can be made, however, also from a synthetic material, preferably an elastomer.

In the case of a special embodiment of the invention the jacket is made from a packet of cup springs.

15

The invention and developments are explained in detail in the following based on the partly schematic illustrations of several embodiments.

They show in:

20

Fig.1 - a perspective view of an intervertebral disk prosthesis,

Fig.2 - a top view on the intervertebral disk prosthesis according to Fig.1,

25 Fig.3 - a longitudinal section along line B-B of Fig.2,

Fig.4 - a version of the intervertebral disk prosthesis according to Fig.1, longitudinally sectioned,

30 Fig.5 - a perspective view on an intervertebral disk prosthesis with a central bore,

Fig.6 - a top view on an intervertebral disk prosthesis according to Fig.5,

Fig.7 - a longitudinal section along line B-B of Fig.6, and

Fig.8 - a perspective view of a partially sectioned intervertebral disk prosthesis with two bellows, inserted into one another.

5 The intervertebral disk prosthesis, illustrated in Figs.1-3, essentially comprises a hollow-cylindrical basic body 1 with a jacket 2 constructed as a bellows, a top end 3, a bottom end 4 and a central longitudinal axis 5. On the top end 3 of the basic body 1 a top apposition plate 6 is provided transversely to the longitudinal axis 5, that is intended as a support for the base plate of a vertebral body. On the bottom
10 end 4 of the basic body 1 a bottom apposition plate 7 is provided transversely to the longitudinal axis 5, that can be placed on the cover plate of a vertebral body.

Both apposition plates 6, 7 have an outwardly structured surface 8, that is made up from a plurality of pyramid-shaped teeth, so that to achieve a better contact
15 with the base and cover plates of the adjacent vertebral bodies. The structured surface 8 can be also realised in the form of etching the surface or in the form of surface structures promoting the adherence of the bone tissue.

The jacket 2, constructed as an external bellows, has altogether three to six folds
20 (waves).

The height of the intervertebral disk prosthesis is 5-15 mm, depending from the embodiment, the diameter is in the range of 10-35 mm and the thickness of the jacket is approx. 0.1 mm.
25

Both apposition plates 6, 7 have inward facing axial spigots 12 and 13, that can be constructed as dampening elements.

In the case of the version illustrated in Fig.4 both apposition plates 6,7 with the inward facing axial spigots 12 and 13 as bearing spigots are rotatably mounted in
30 a housing 14, while the rotation can be limited by stops (not illustrated).

The embodiment of an intervertebral disk prosthesis, shown in Figs.5-7, is similarly constructed to those according to Figs.1-3. The difference is that both

apposition surfaces 6, 7 are constructed as annuluses, so that a bore 9, axially passing through it, will result. A further difference is that in the case of this embodiment the jacket 2, constructed as bellows, has only one fold (wave).

- 5 Fig.8 shows particularly graphically the operation of the intervertebral disk prosthesis. In the case of this embodiment the jacket 2 comprises an external bellows 21 and an internal bellows 22. The external bellows 21 has five folds and the internal bellows 22 has nine folds. The external bellows 21 is fastened on the top apposition plate 6 and the internal bellows 22 on the bottom apposition plate
- 10 7. Depending on the material the bellows can be welded to the apposition plates 5, 6, caulked or pressed into them. In the embodiment illustrated both bellows 21, 22 are let into annular grooves 10 and 11, that are provided on the inside of both apposition plates 6, 7. As Fig.8 illustrates, the two apposition plates 5, 6, that can be fastened on a bellows 21, 22 each, can be fitted together to form a box.
- 15 Consequently the two apposition plates 5, 6 can rotate relative one another. By virtue of a stop (not illustrated) the rotation can be limited to a predetermined value, e.g. 2°-3°.

English translation of the amendments as annexed to the International Preliminary Examination Report of the International Patent Application No. PCT/CH2002/000582 "Intervertebral disk prosthesis or artificial vertebra" in the
5 name of Mathys Medizinaltechnik AG

Patent claims

1. An intervertebral disk prosthesis or an artificial vertebral body with
 - 10 A) an essentially hollow-cylindrical basic body (1) with a jacket (2) constructed as a bellows, a top end (3), a bottom end (4) and a central longitudinal axis (5),
 - B) a top apposition plate (6), provided transversely to the longitudinal axis (5) on the top end (3) of the basic body (1), that is intended as a support for the
15 base plate of a vertebral body, and
 - C) a bottom apposition plate (7), provided transversely to the longitudinal axis (5) on the bottom end (4) of the basic body 1, that can be placed on the cover plate of a vertebral body, and
 - 20 D) the jacket (2), constructed as a bellows, is constructed as a spring element with a specific spring rate.
characterised in that
 - E) the jacket (2) comprises a plurality of bellows inserted into one another.
2. An intervertebral disk prosthesis or an artificial vertebral body according to
25 claim 1, characterised in that the specific spring rate is minimum 50 N/mm, preferably minimum 100 N/mm.
3. An intervertebral disk prosthesis or an artificial vertebral body according to
30 claim 2, characterised in that the spring rate is minimum 150 N/mm, preferably minimum 400 N/mm.
4. An intervertebral disk prosthesis or an artificial vertebral body according to any one of claims 1 to 3, characterised in that the spring rate is maximum 800 N/mm, preferably maximum 2000 N/mm.

**AMENDED
SHEET**

5. An intervertebral disk prosthesis or an artificial vertebral body according to any one of claims 1 to 4, characterised in that under a load of 1000 N the spring travel of the spring element is in the range of 1-2 mm, preferably in the range of 1.3-1.7 mm.
6. An intervertebral disk prosthesis or an artificial vertebral body according to any one of claims 1 to 5, characterised in that the spring element is both a tensile spring and a compression spring.
7. An intervertebral disk prosthesis or an artificial vertebral body according to any one of claims 1 to 6, characterised in that the number of folds of the jacket (2), constructed as a bellows, is in the range of 3-10.
8. An intervertebral disk prosthesis or an artificial vertebral body according to claim 7, characterised in that the number of folds of the jacket (2), constructed as a bellows, is in the range of 4-5.
9. An intervertebral disk prosthesis or an artificial vertebral body according to any one of claims 1 to 8, characterised in that the jacket (2) comprises a plurality of single layers.
10. An intervertebral disk prosthesis or an artificial vertebral body according to any one of claims 1 to 9, characterised in that the single layers of the jacket (2) are spaced from one another.
11. An intervertebral disk prosthesis or an artificial vertebral body according to any one of claims 1 to 9, characterised in that the single layers of the jacket (2) abut against one another without intermediate layers.
12. An intervertebral disk prosthesis or an artificial vertebral body according to any one of claims 1 to 11, characterised in that the jacket has slots that extend basically parallel to the longitudinal axis (5).

**AMENDED
SHEET**

13. An intervertebral disk prosthesis or an artificial vertebral body according to any one of claims 1 to 12, characterised in that the rotational stiffness of the jacket (2) allows a 1° - 3° rotation of the jacket, preferably 1.5° - 2.5° .
- 5
14. An intervertebral disk prosthesis or an artificial vertebral body according to any one of claims 1 to 13, characterised in that when an axial force of 800 N is applied, the axial stroke of the jacket is in the range of 1.0-2.5 mm, preferably in the range of 1.30-1.75 mm.
- 10
15. An intervertebral disk prosthesis or an artificial vertebral body according to any one of claims 1 to 14, characterised in that both apposition plates (6, 7) are fastened on the top and bottom ends (3, 4) of the basic body (1) axially firmly but enabling rotation.
- 15
16. An intervertebral disk prosthesis or an artificial vertebral body according to any one of claims 1 to 15, characterised in that both apposition plates (6, 7) are axially fastened on the top and bottom ends (3, 4) of the basic body (1) and their rotation about the longitudinal axis (5) is limited, preferably to an angular range of maximum 5° .
- 20
17. An intervertebral disk prosthesis or an artificial vertebral body according to any one of claims 1 to 15, characterised in that both apposition plates (6, 7) are fastened on the top and bottom ends (3, 4) of the basic body (1) axially firmly and unable to rotate.
- 25
18. An intervertebral disk prosthesis or an artificial vertebral body according to claim 17, characterised in that the rotational stiffness of the jacket (2) constructed as bellows is so chosen, that both apposition plates (6, 7) can rotate relative one another about the longitudinal axis (5) by an angle of 1° - 5° , preferably 2° - 3° .
- 30

AMENDED SHEET

19. An intervertebral disk prosthesis or an artificial vertebral body according to any one of claims 1 to 18, characterised in that both apposition plates (6, 7) can be tilted from the plane that is orthogonal to the longitudinal axis (5) by an angle of 4°-8°, preferably 5°-7°.
- 5
20. An intervertebral disk prosthesis or an artificial vertebral body according to any one of claims 1 to 19, characterised in that the hollow-cylindrical basic body (1) is filled at least partially with a solid body, acting as a dampening element.
- 10
21. An intervertebral disk prosthesis or an artificial vertebral body according to claim 20, characterised in that the solid body is a synthetic material, preferably an elastomer.
- 15
22. An intervertebral disk prosthesis or an artificial vertebral body according to any one of claims 1 to 21, characterised in that the jacket (2) is made from a metal or a metal alloy, preferably based on titanium.
- 20
23. An intervertebral disk prosthesis or an artificial vertebral body according to any one of claims 1 to 22, characterised in that the material of the jacket (2) has a minimum stretch limit of 30 %, preferably a minimum of 38 %.
- 25
24. An intervertebral disk prosthesis or an artificial vertebral body according to any one of claims 1 to 21, characterised in that the jacket (2) is made from a synthetic material, preferably an elastomer.
- 30
25. An intervertebral disk prosthesis or an artificial vertebral body according to any one of claims 1 to 24, characterised in that the jacket (2) is made from a packet of cup springs.

AMENDED SHEET

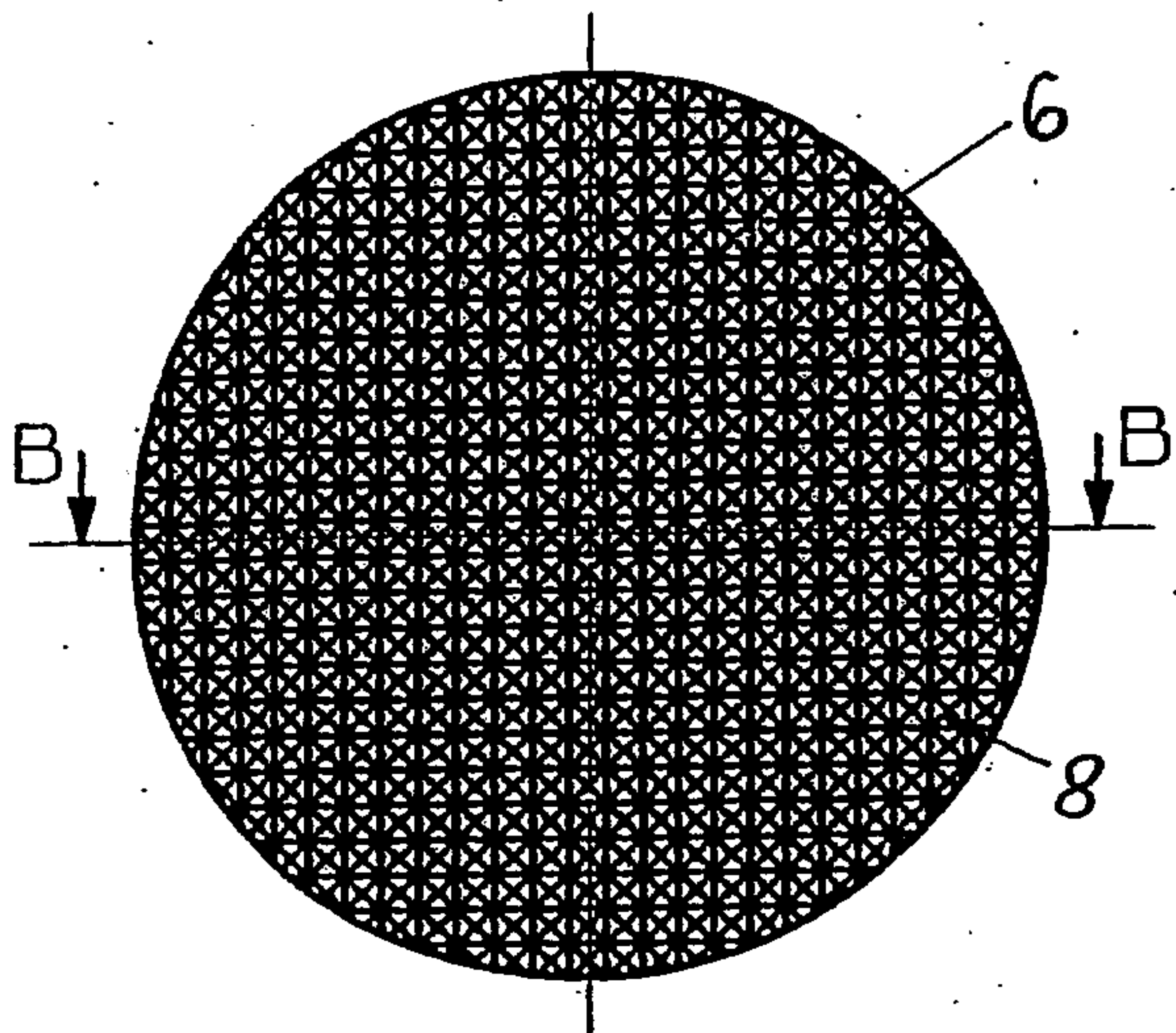

Fig. 2

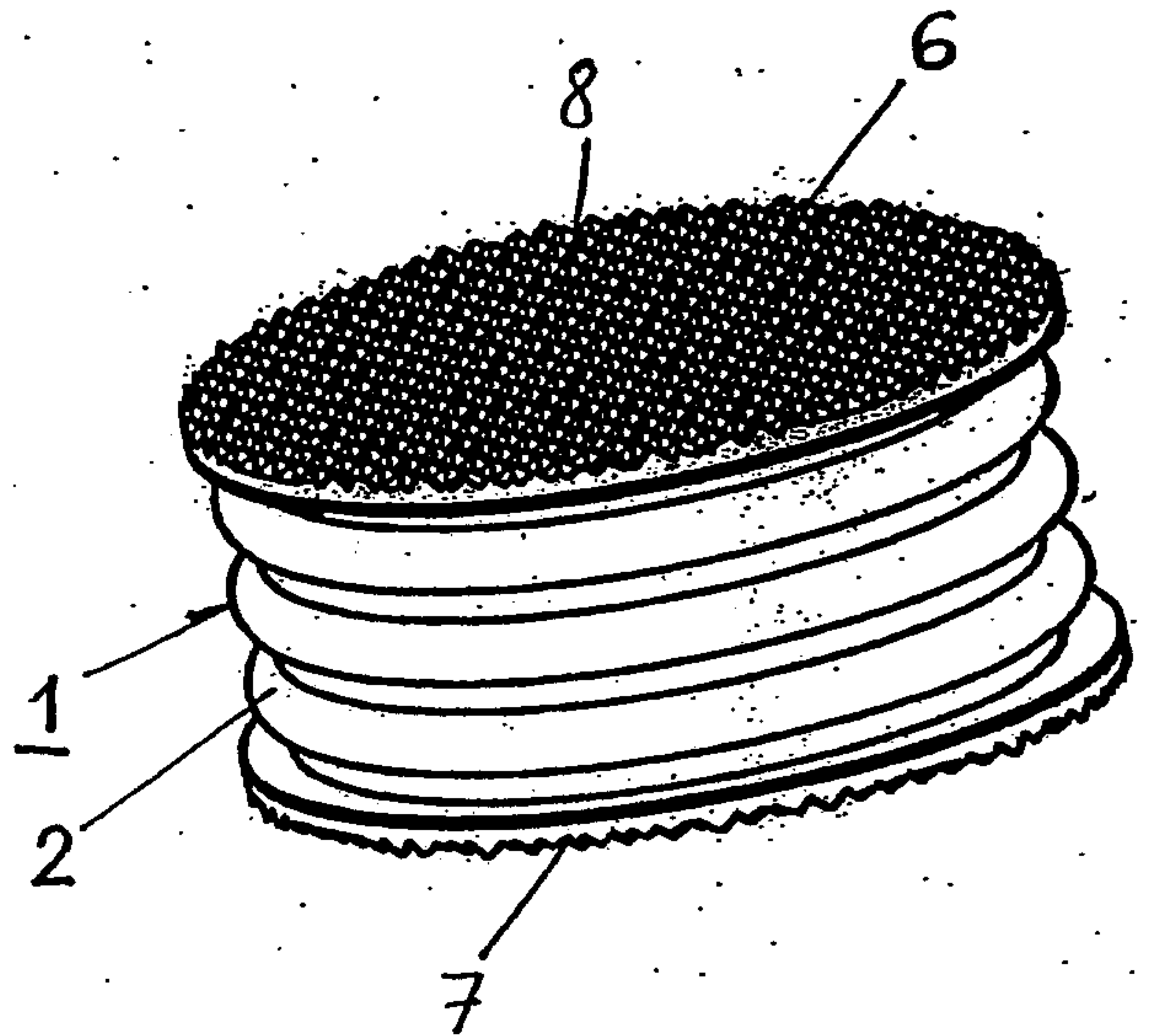

Fig. 1

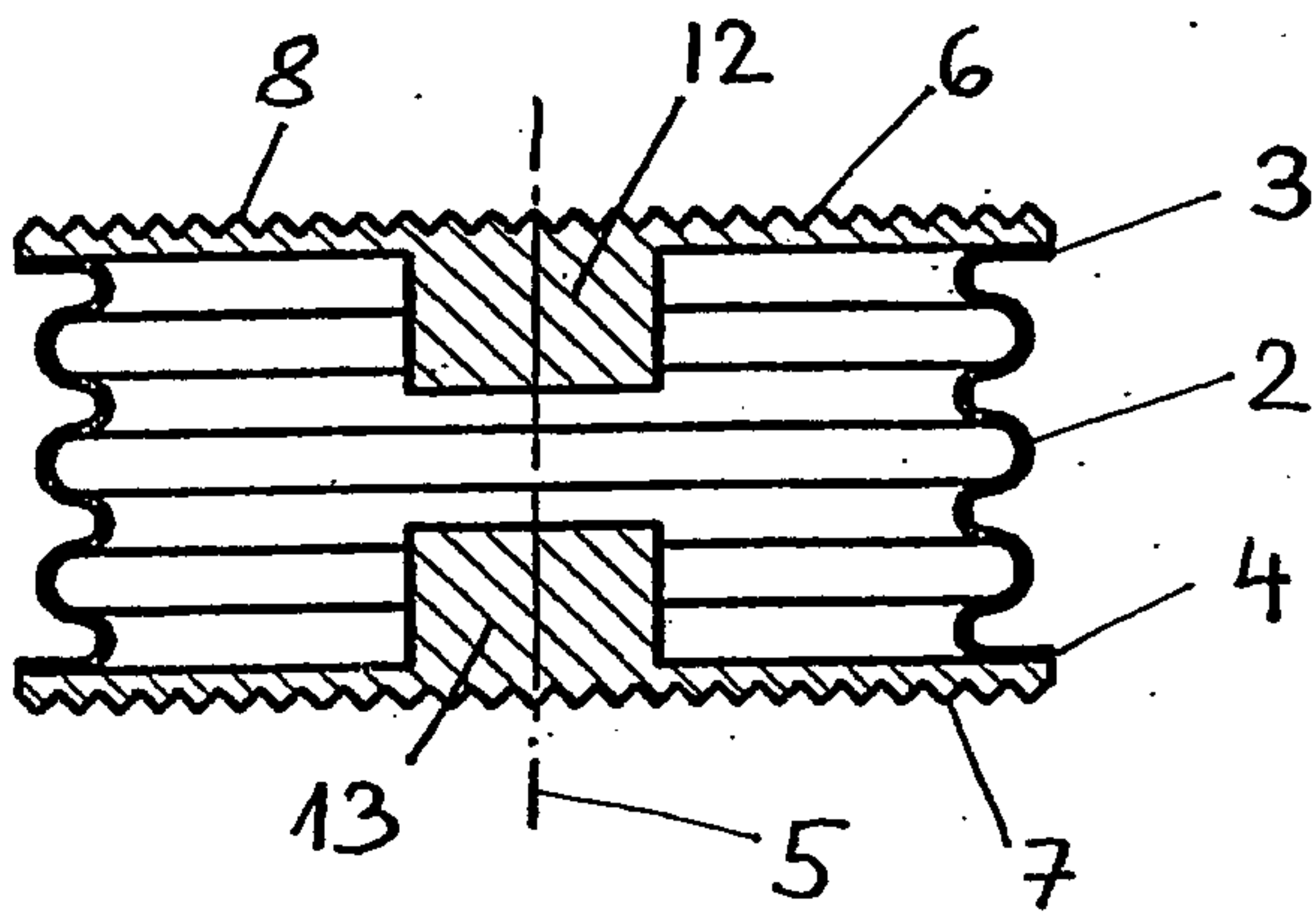

Fig. 3

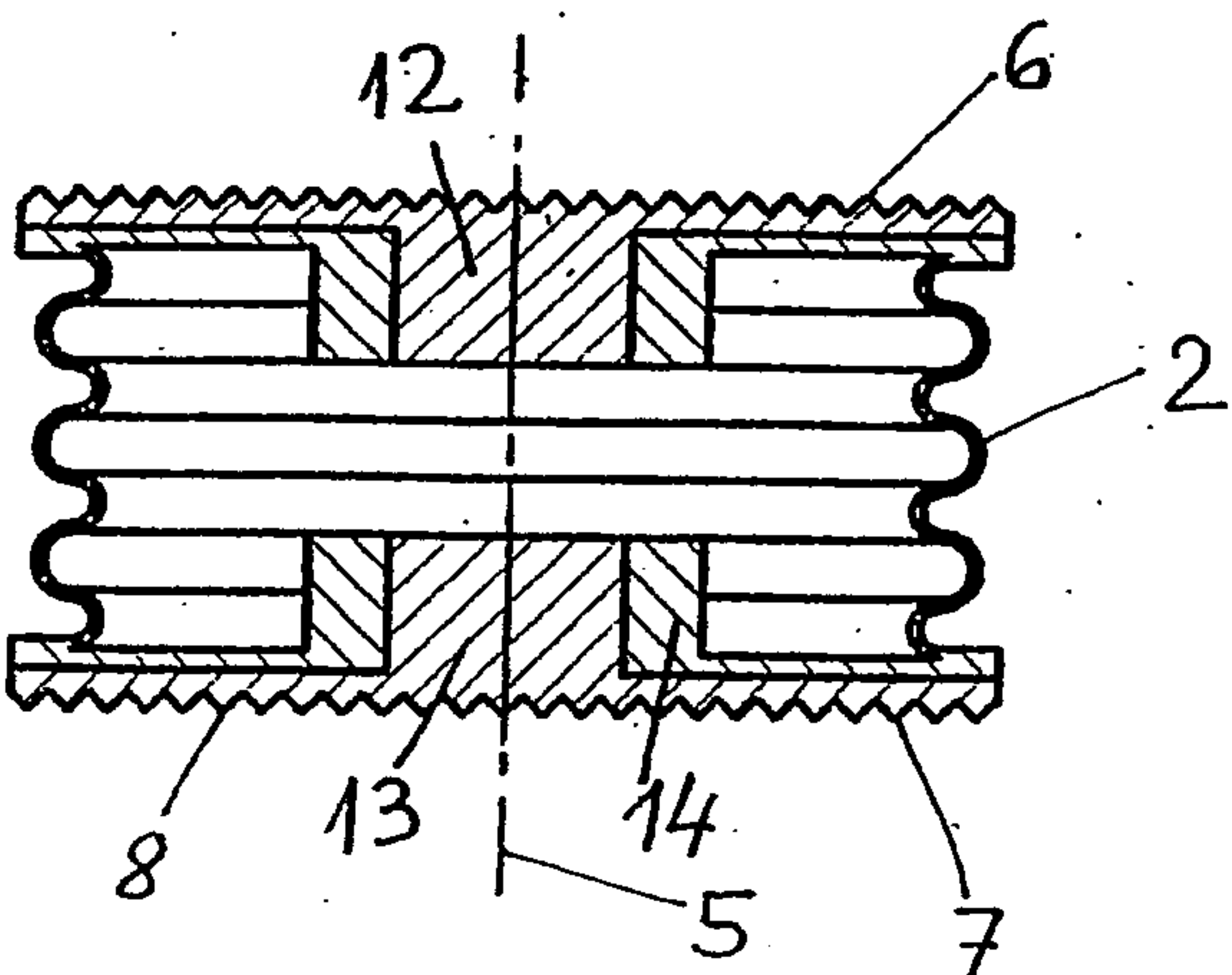

Fig. 4

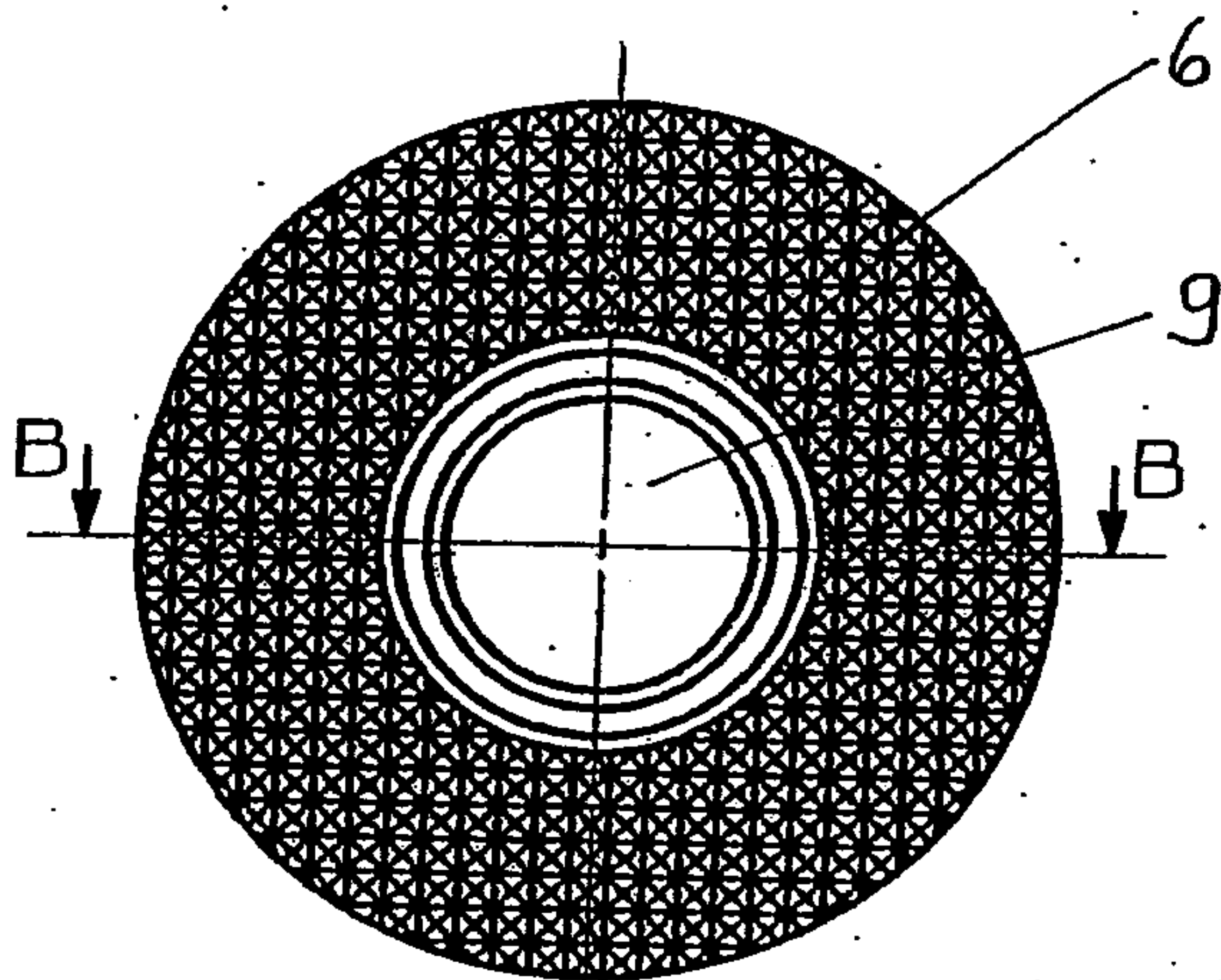

Fig. 6

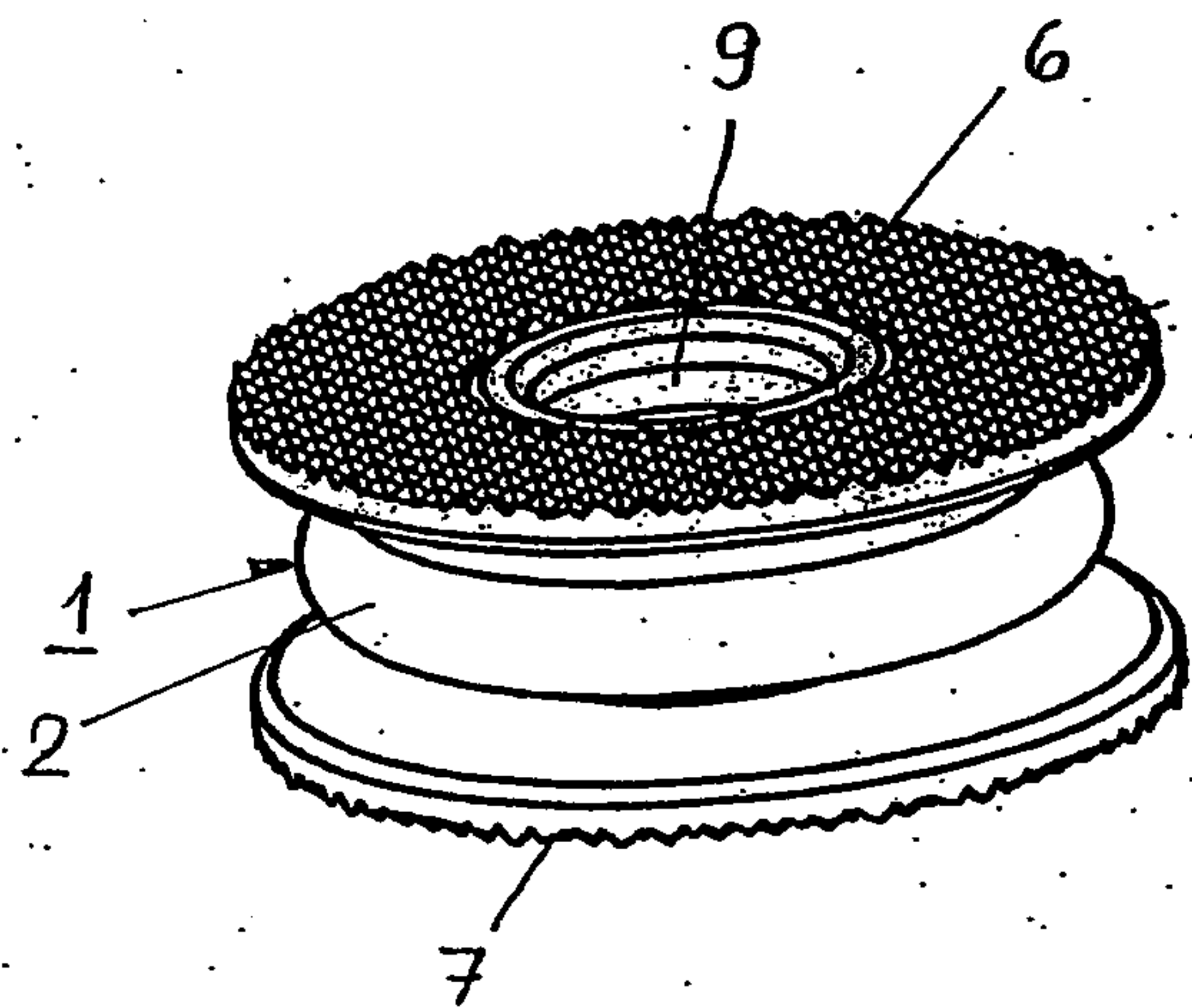

Fig. 5

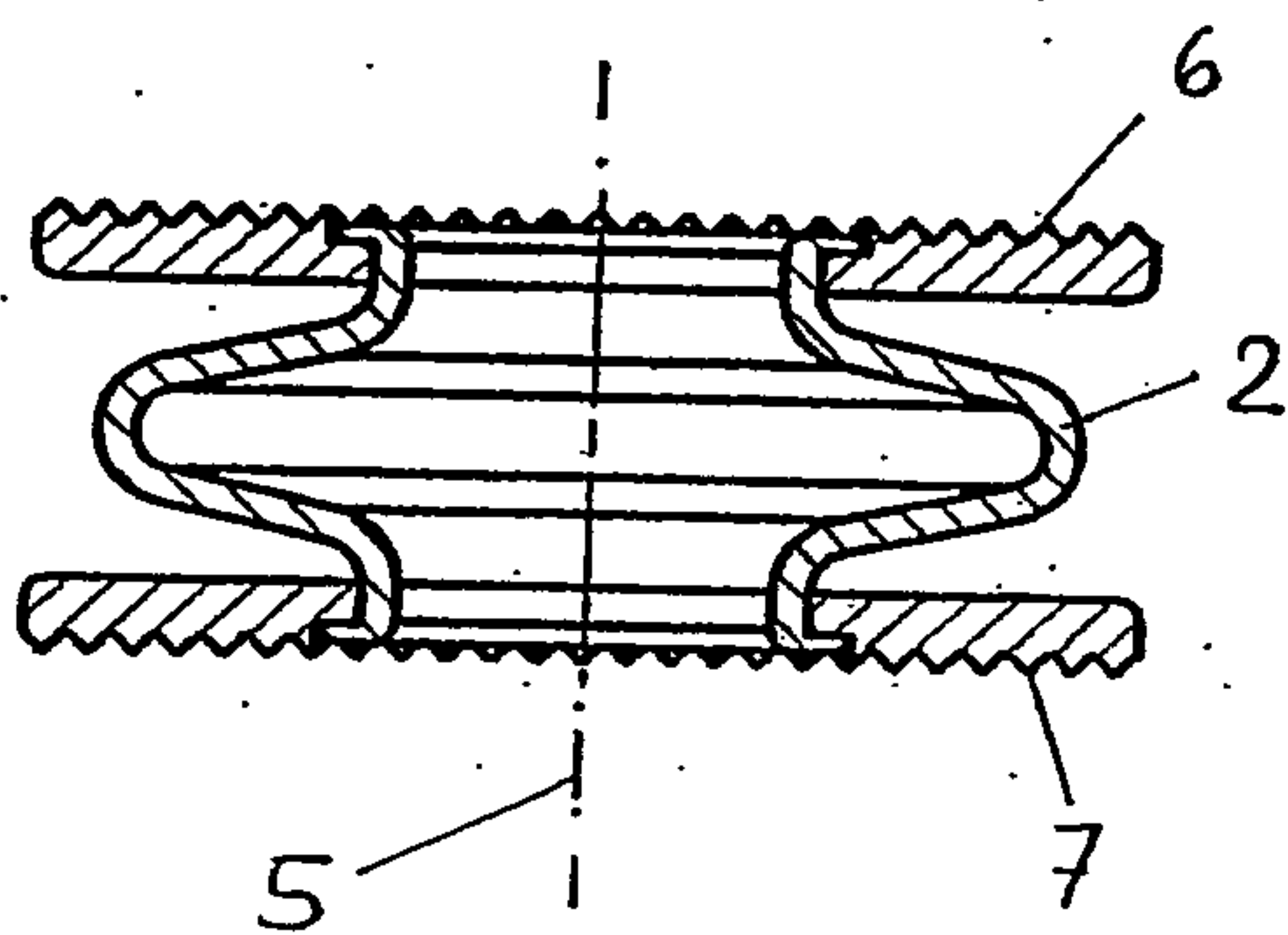

Fig. 7

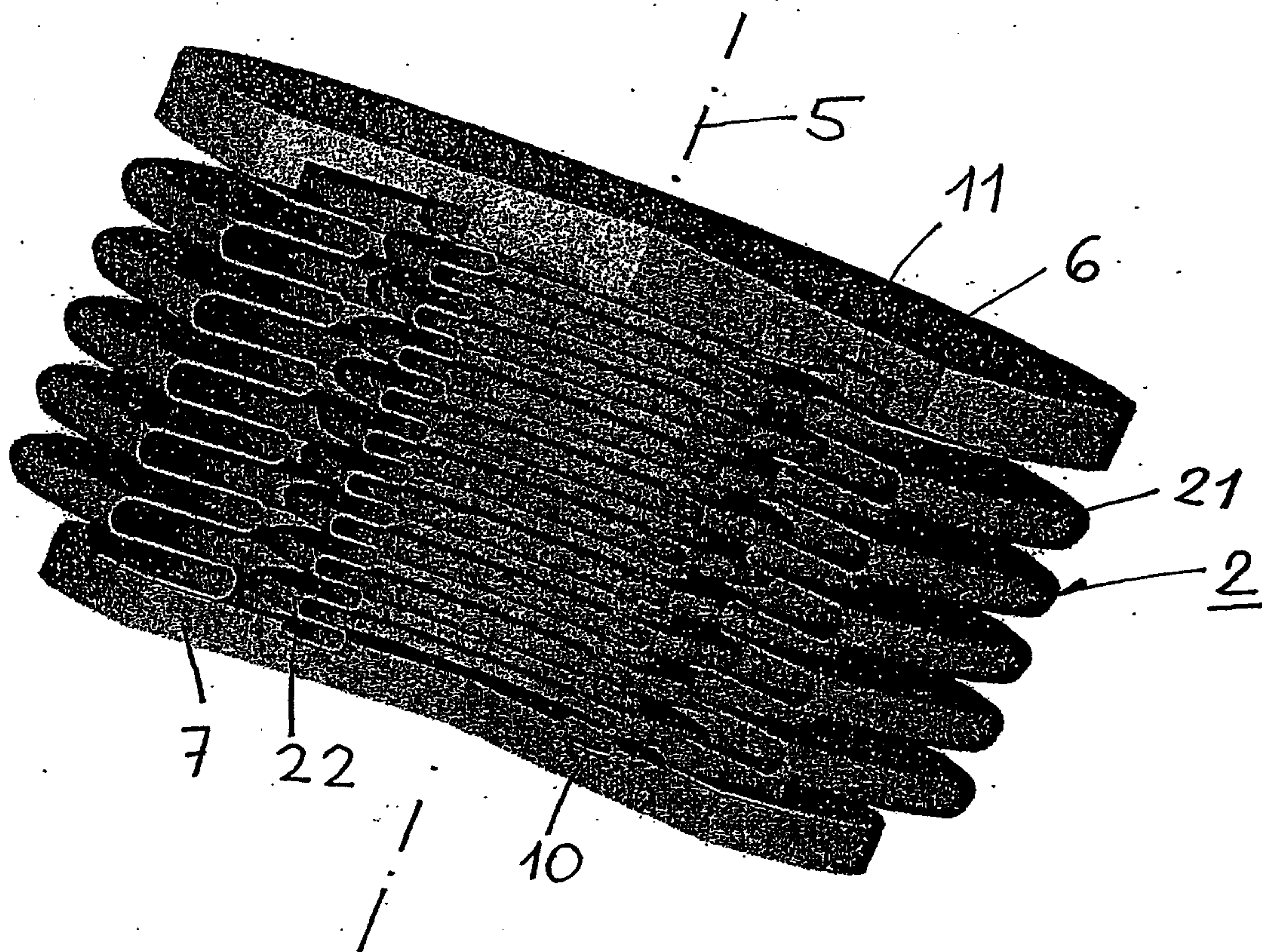

Fig. 8

