

William W. Dunn's
Machine for Making Type.

Sheet No. 1.

111111

PATENTED JAN 24 1871

Fig. 1.

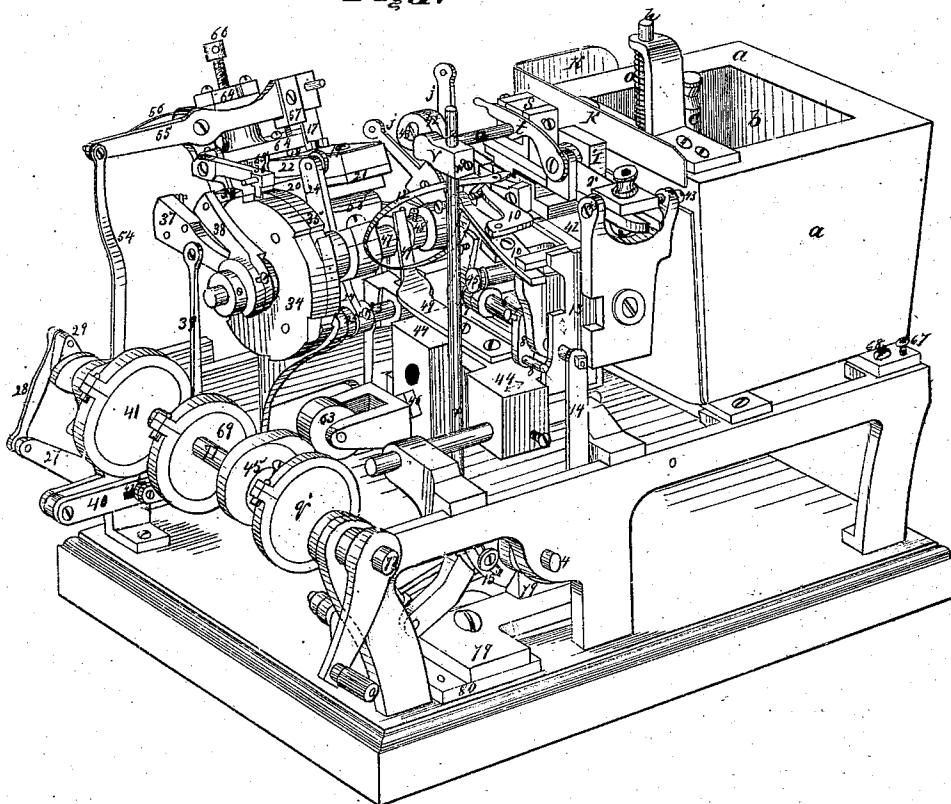

Witnesses:

David R. Smith,
John Corse.

Inventor:

William W. Dunn,
By C. W. M. Smith *att'y.*

11,111
 Dunn's machine for making type #2

Fig. 3

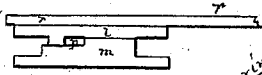

Fig. 2

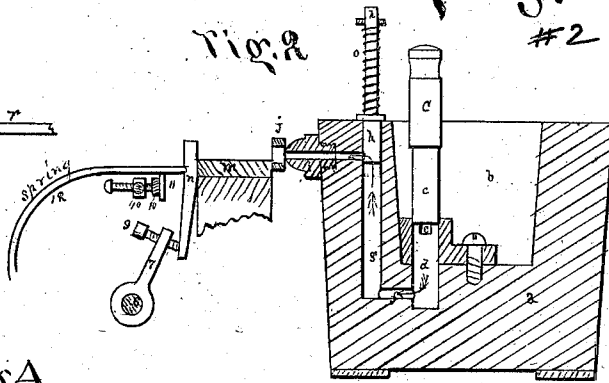

Fig. 4

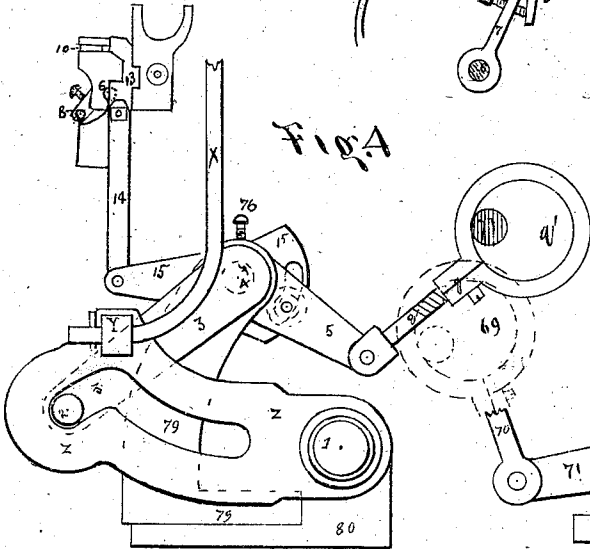

Fig. 5

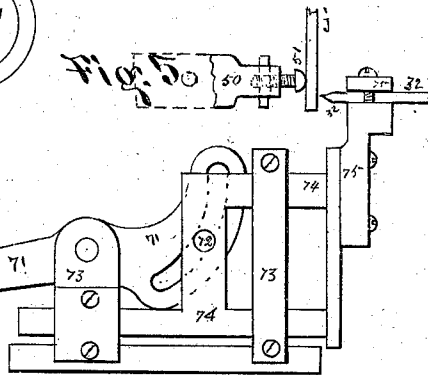
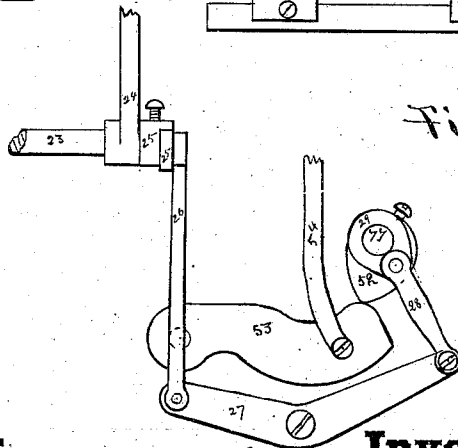

Fig. 6



Sheet 2

Witnesses:

David R. Smith

John Corse

Inventor:

William R. Dunn
By G. M. Smith, Attorney

///,///

Dunn's Machine for Making Type

Fig. 8

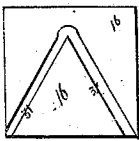

Fig. 7

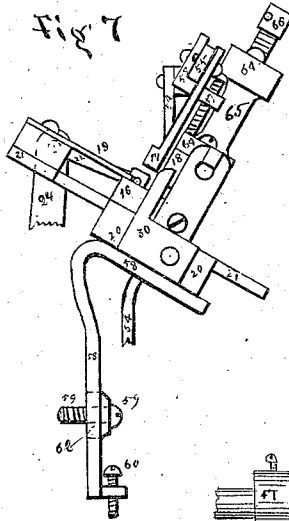

Fig. 9

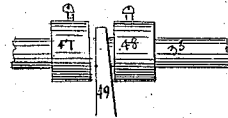
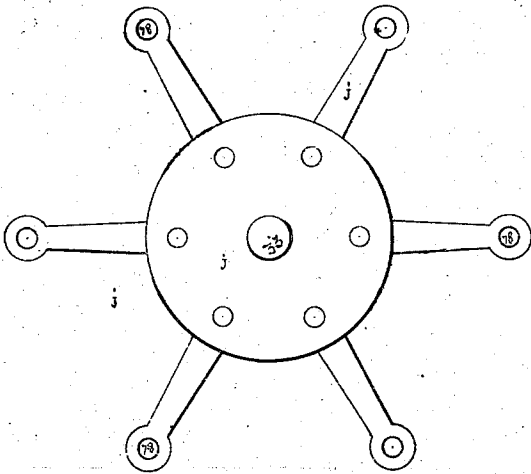
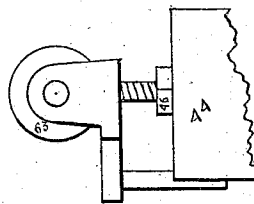

Fig. 10



Sheet 3

Witnesses:

David R. Smith.
John Gosse

Inventor:

William R. Dunn
By G. W. Smith, atty.

United States Patent Office.

WILLIAM WALLACE DUNN, OF SAN FRANCISCO, CALIFORNIA.

Letters Patent No. 111,111, dated January 24, 1871.

IMPROVEMENT IN TYPE-CASTING MACHINES.

The Schedule referred to in these Letters Patent and making part of the same.

To all whom it may concern:

Be it known that I, WILLIAM W. DUNN, of the city and county of San Francisco, State of California, have invented certain new and useful Improvements in "Machines for Making Type;" and I do hereby declare that the following is a full and exact description of the same, reference being had to the accompanying drawing and to the letters marked thereon.

My invention relates to that class of machines for casting type which is provided with devices for breaking off the superfluous metal and dressing the type, and consists in certain details of construction which will hereinafter more fully appear.

In the annexed drawing—

Figure 1, sheet 1, is a perspective view of a machine embodying my invention;

Figures 2, 3, 4, 5, and 6, sheet 2, and

Figures 7, 8, 9, and 10, sheet 3, are details.

Like letters refer to like parts in each of the figures.

The melting-pot *a* is heated by a furnace, not shown in the drawing, and

The cavity *b* is kept continually supplied with molten metal.

The plunger *c* has a vertical reciprocating motion imparted to it by suitable machinery, not shown.

This plunger is shown in its highest position in fig. 2, sheet 2, in which position the cylinder or well *d* will fill with metal through the passage *e*.

The sectional area of the plunger is such, and its length of stroke so adjusted, that in descending it will displace just enough metal to form one type, and force it out through the passage *f* up through passage *g*, raising the cylindrical valve *h* and discharging through the nipple *i* to the carrier or spider *j* and the mold.

When the plunger *c* begins its upward stroke the valve *h* will be immediately forced downward by the spring *o* closing the passage to the nipple.

Increasing the length of the stroke of the plunger will compensate for leakage around or imperfect filling of the plunger or valve.

To prevent the excessive heating of the mold a screen, *k*, is provided, between which and the melting-pot an air passage should be made.

The mold or matrix consists of three pieces, *l m n*, figs. 2 and 3, all or either of which can be readily removed or exchanged at will in order to mold different forms of type.

The rectangular space *p*, formed by the pieces *l* and *m*, is closed at its outer end by the rocking piece *n*, fig. 2, upon which the matrix for the letter or character is formed; and a separate rocking piece, *n*, should be provided for each character or letter.

The molten metal flowing from the nipple fills not only the mold but the opening in passage 78, fig. 4, in the end of the arm of the carrier or spider *j*, and forms between the spider and the type a gate of metal.

As soon as the casting is thus performed the mold is opened and the type released by means of the following devices, the motions of which are derived from the eccentric *q*, fig. 1:

First, the upper part *l* of the mold is raised up out of the way and returned to its position by means of the hinged plate *r*, to which is attached the swivel-box nut *s*, fig. 1, in which is secured by means of the drop-catch *t*, the horizontal arm *u*.

The arm *u* is secured by means of the sliding arm *v* and screw *w* to a vertical rod *x*; the rod *x* is connected by means of the swivel-pin *y* to the cam *z*, fig. 1.

The cam *z* is so formed as to give the required motion through the intervening mechanism to the upper piece *l* of the mold, said cam *z* being hinged at 1, and receiving its motion from a pin, 2, on the extremity of the rock-shaft arm 3, fig. 4.

The shaft 4, from which arm 3 proceeds, is connected to the rod *q* of eccentric *q* by means of arm 5.

Second, the rocking piece *n* is caused to leave the face of the type by means of the rock-shaft 6, fig. 2, and arms 7 and 8, adjusted by the set-screw 9, and caused to return to the mold by means of the adjustable lever 10 acting on an arm, 11, attached to the spring 12.

Both the rock-shaft 6 and the lever 10 are operated by the sliding-cam plate 13, fig. 1, and the cam-plate 13 is impelled by the rod 14, connected with the adjustable rock-shaft arm 15 of shaft 4.

As soon as the type is released from the mold, it is carried over by the spider *j* and deposited on the type landing or cutter-plate 16, grasped or held in a proper position by the foot 17 and forced through between cutter 18 and breaker 30, and cutter-plate 16 by the type-slice 19 onto the cutter bed-plate 20, fig. 7.

The required reciprocating motion is imparted to the slice by means of the guide-plate 21, connecting-rod 22, rock-shaft 23, arms 24 and 25, connecting-rod 26, lever 27, connecting-rod 28, and crank 29.

The type-landing or cutter-plate 16 is rigidly secured to the bed-plate 20, and is provided with diagonal cutter 31, that plane and trim or shave the underside of the type as it passes over them, while the cutter 18 trims the top.

Breaker 30 separates the gate from the type; the gate being still retained in the spider-arm is carried

around until the extremity of the arm is opposite to the needle or punch 32, when it is forced out and the recess or opening in the arm thus cleared is readiness to repeat its operation with another type.

The spider, seen in the drawing, has six arms secured to a flange on the shaft 33, consequently the shaft 33 is rotated one-sixth of a revolution each time that a type is cast by means of the ratchet-wheel 34, stop-wheel 35, stop-pawl 36, and pawl-arms and pawls 37 and 38, connecting-rod 39, lever 40, and eccentric 41.

The rod of eccentric 41 is connected to lever 40 by means of a pin secured in a slot, 42', in the lever.

The slotted connection is for the purpose of regulating the throw of the lever 40.

The plate or mold-seat 42, carrying the matrix and the machinery connected with the eccentric *g*, is hinged and secured and adjusted by the screws 43 and set or binding-screws 45' to a vertical plate firmly attached to or forming a part of the moving or sliding bed 44.

The sliding bed 44 is forced toward the melting-pot by the cam 45 and roller 63, and toward the cam 45 by a suitable spring; said roller and spring are so constructed and adjusted that when the mold is being filled the face of the mold will press the arm of the carrier tight against the nipple and prevent leakage of metal, and after the mold is filled separate the metal from the end of the nipple by moving both the carrier and the mold away from the nipple.

For the better adjustment of the motion of the moving-bed a set-nut, 46, is provided.

For the purpose of imparting the required corresponding motion to the spider an end-long motion is given to the shaft 33 by means of the collars 47 and 48, between which works an arm, 49, rigidly attached to the moving-bed, figs. 10 and 1.

To the moving-bed is also attached another stout arm, 50, at the extremity of which is a set-screw, 51, that provides a support for the extremity of the arms of the carrier during the operation of the punch 32 in driving out the gates, fig. 5.

The foot 17 is operated by means of the cam 52, the lever 53, rod 54, lever 55, spring 56, and adjusted by means of a set-screw projecting through the plate 57.

The cutter-bed plate 20 is secured in an inclined position to the top of the frame 58.

Frame 58 is secured to the principal frame of the machine by the set-screws 59, and adjusting-screws 60, and slot 62, in such a manner as to be readily adjusted in regard to height, and according to the thickness of the type.

The box-nut *s*, fig. 1, is swiveled for the purpose of obtaining a direct and even pressure for causing the face or parts of the mold to come squarely together.

The cutter 18 is secured to the holder 64, and is raised or lowered to conform to type of different thickness by the sliding of the holders on the pillar or rod 65, adjusted and secured by the screws 66; the pitch of that part of screw 66 that works in the top plate of the holder being different from the pitch of the part working in the pillar or rod 65.

The melting-pot may be leveled, tilted, or adjusted by means of the adjusting-screws 67 and the holding-down screws 68.

The required horizontal motion is imparted to the punch or needle 32 by the eccentric 69, eccentric-rod 70, cam 71, pin 72, guide-frame 73, sliding-plate 74, and clamp 75, fig. 5.

The office of the foot 17 is very important in holding the type firmly down on the type-landing, and preventing it from being turned or tilted over by the cutter 18 or being thrown out of place by the leverage of the gate over the breakers 30.

The operation of the slice in bearing uniformly on

the type throughout its length and forcing said type laterally through the cutter, prevents the possibility of bending or injuring said type during the trimming, rubbing, or planing.

The time of the movements of the parts of the type-mold is regulated by the relative angular position of the arms 3, 5, and 15, on shaft 4, said angular position being adjusted by means of the set-screws 76.

77 is the driving-shaft that communicates motion to all the moving parts.

The holes or recess 78 in the extremities of the arms of the carrier, or spider *j*, are tapered, having their largest end toward the mold.

These holes are thus tapered in order to prevent the gate from being drawn through them toward the nipple, and thus breaking the gate off of the type while the type is still in the mold.

The screen *k* is an important device, for the reason that without it the mold would become so heated by the radiation from the melting-pot that the metal would not have time to chill in them unless the casting was proceeded with much more slowly than is necessary with my invention.

The adjusting-screws 67 are particularly required to adjust the height of the nipple to the center of the holes 78, in the carrier *j*; after the melting-pot has become expanded by heat, of course, the screws 67 may be placed in the forward lugs of the melting-pot if desired, or wedges may be used in their stead.

The nipple *i*, foot 17, and punch 32, are equidistant from each other and from the center line of the shaft 33, their distance from the center line of the shaft being just equal to the distance of the center of the holes 78 from the same line.

The filling of the mold through one arm; the clamping of a type by the foot 17, and the driving of the gate out of the hole 78 of the lower arm being simultaneous operations, it is evident that the number of arms to the spider may be any multiple of three, provided that the hereinbefore described machinery for giving motion to shaft 33 is proportioned so as to correspond to the number of said arms, that is, if only three arms are used the shaft should make one-third of a revolution for each type that is cast; or, if nine arms are used, one-ninth of a revolution.

Having thus described my invention I do not claim broadly the employment, in type-making machines, of the melting-pot *a*, nipple *i*, carrier or spider *j*, or a hollow flange for forcing out the metal, nor do I claim any peculiarity in the mold or matrix *l m n*, hinged plate *r*, adjustable lever 10, or spring 12, nor hinging, securing, or adjusting the mold-seat 42 to a bed by the screws 43 and 45'.

Neither do I claim, broadly, operating the machinery connected with the casting of type by a revolving shaft, nor the employment of the cam 45 and roller 63 for the purpose of causing the matrix or mold to approach and recede from the nipple *i*; but

What I do claim as new in machines for making type, and desire to secure by Letters Patent, is—

1. The eccentrics *g*, and rod *g*, arm 5, rock-shaft 4, adjustable arm 15, rod 14, cam-plate 13, rock-shaft 6, arms 7 and 8, set-screws 9, adjustable lever 10, and spring 12, combined and arranged substantially as described, and for the purpose set forth.
2. The cutter 18 in combination with the holder 64, pillar 65, and screw 66.
3. The punch 32 in combination with the arm 50 and set-screw 51, substantially as and for the purpose set forth.
4. The arrangement of the eccentric 69, rod 70, cam 71, pin 72, guide-frame 73, sliding-plate 74, and clamp 75, when employed in connection with the punch 32, as described.

5. The presser-foot 17, in combination with lever 55, having the adjusting-plate 57 and spring 56, as shown and described.

6. The combination of the frame 58, the cutter-bed plate 20, cutter 18, breaker 30, and cutter-plate or type landing 16, with the foot 17 and type-slicer 19, when the parts are arranged as described for the purpose set forth.

In testimony whereof I have hereunto set my hand and seal.

W. W. DUNN. [L. S.]

Witnesses:

CALEB T. FAY,
C. W. M. SMITH.