



(51) International Patent Classification:

*B64G 1/10* (2006.01)      *B64G 1/44* (2006.01)  
*B64G 1/22* (2006.01)      *B64G 1/58* (2006.01)

(21) International Application Number:

PCT/US2011/049190

(22) International Filing Date:

25 August 2011 (25.08.2011)

(25) Filing Language:

English

(26) Publication Language:

English

(30) Priority Data:

13/026,175      11 February 2011 (11.02.2011)      US

(71) Applicant (for all designated States except US): **SPACE SYSTEMS/LORAL, INC.** [US/US]; 3825 Fabian Way – M/S G79, Palo Alto, California 94303 (US).

(72) Inventor; and

(75) Inventor/Applicant (for US only): **GELON, Walter** [US/US]; 622 Island Place, Redwood City, California 94065 (US).

(74) Agents: **DAY, Michael, L.** et al.; WEAVER AUSTIN VILLENEUVE & SAMPSON LLP, P. O. Box 70250, Oakland, California 94612-0250 (US).

(81) Designated States (unless otherwise indicated, for every

kind of national protection available): AE, AG, AL, AM, AO, AT, AU, AZ, BA, BB, BG, BH, BR, BW, BY, BZ, CA, CH, CL, CN, CO, CR, CU, CZ, DE, DK, DM, DO, DZ, EC, EE, EG, ES, FI, GB, GD, GE, GH, GM, GT, HN, HR, HU, ID, IL, IN, IS, JP, KE, KG, KM, KN, KP, KR, KZ, LA, LC, LK, LR, LS, LT, LU, LY, MA, MD, ME, MG, MK, MN, MW, MX, MY, MZ, NA, NG, NI, NO, NZ, OM, PE, PG, PH, PL, PT, QA, RO, RS, RU, SC, SD, SE, SG, SK, SL, SM, ST, SV, SY, TH, TJ, TM, TN, TR, TT, TZ, UA, UG, US, UZ, VC, VN, ZA, ZM, ZW.

(84) Designated States (unless otherwise indicated, for every

kind of regional protection available): ARIPO (BW, GH, GM, KE, LR, LS, MW, MZ, NA, SD, SL, SZ, TZ, UG, ZM, ZW), Eurasian (AM, AZ, BY, KG, KZ, MD, RU, TJ, TM), European (AL, AT, BE, BG, CH, CY, CZ, DE, DK, EE, ES, FI, FR, GB, GR, HR, HU, IE, IS, IT, LT, LU, LV, MC, MK, MT, NL, NO, PL, PT, RO, RS, SE, SI, SK, SM, TR), OAPI (BF, BJ, CF, CG, CI, CM, GA, GN, GQ, GW, ML, MR, NE, SN, TD, TG).

Published:

— with international search report (Art. 21(3))

(54) Title: SATELLITE HAVING MULTIPLE ASPECT RATIOS

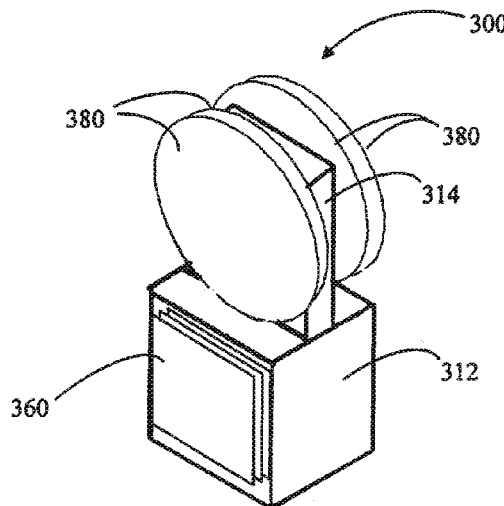

FIG. 3

(57) Abstract: A high capacity satellite (300) having multiple aspect ratios is configured to have at least two modules (312, 314). Each module includes a first panel and a third panel facing, in an on-orbit configuration, respectively, toward north and south and having a width in an east-west direction (EW width); and a second and a fourth panel oriented, in the on-orbit configuration, respectively, east and west and having a width in the north-south direction (NS width). Each module has a respective aspect ratio of EW width to NS width, a first module (312) is configured with a first aspect ratio, a second module (314) is configured with a second aspect ratio; and the second aspect ratio is substantially larger than the first aspect ratio. At least one antenna reflector (380) is disposed, during launch, proximate to at least one of the first and third panel of the second module.



# SATELLITE HAVING MULTIPLE ASPECT RATIOS

## CROSS REFERENCE TO RELATED APPLICATION

[0001] This application claims priority to U.S. Patent Application No. 13/026,175, filed February 11, 2011, the disclosure of which is incorporated herein by reference in its entirety and for all purposes.

## TECHNICAL FIELD

[0002] This invention relates generally to a spacecraft providing communications and/or broadcast service, and particularly to a configuration of such satellite having multiple aspect ratios.

10

## BACKGROUND OF THE INVENTION

[0003] The assignee of the present invention manufactures and deploys spacecraft for, inter alia, communications and broadcast services. Market demands for such spacecraft have imposed increasingly stringent requirements on spacecraft payload capacity. To meet these demands, higher power spacecraft with larger antenna apertures are desirable.

[0004] Launch vehicle compatibility is a second requirement faced by a spacecraft designer. The increased performance requirements are only advantageously met if compatibility with conventional, commercially available launch vehicles is maintained. Accordingly, a spacecraft, as configured for launch, is desirably made compatible with the mass and fairing envelope constraints of such launch vehicles as, for example, Ariane V, Atlas XEPF, Proton, and Sea Launch.

[0005] Thus, there is a need for a high capacity spacecraft that is compatible with such conventional launch vehicle constraints.

## SUMMARY OF INVENTION

[0006] The present inventor has recognized that a high capacity spacecraft payload may be achieved by a satellite having a "multiple aspect ratio" configuration that permits substantially larger spacecraft elements, including north and south radiator surfaces, antenna reflectors, and solar array panels, to be configured for launch within the launch envelope of conventional launch vehicles. As a result of the multiple aspect ratio configuration, a spacecraft may be configured to consist of at least two

modules, each module comprising four external panels. For each module, a first and third external panel may be configured to normally face, in an on-orbit configuration, respectively, toward north and south; a second and a fourth external panel, may be configured to normally face, in the on-orbit configuration, respectively, east and west.

5 Each of the first and third panels may have a width in an east-west direction (EW width); each of the second and fourth panels may have a width in a north-south direction (NS width). Each module has a respective aspect ratio of EW width to NS width. The first module may be configured with a first aspect ratio, and the second module may be configured with a second aspect ratio such that the second aspect ratio  
10 is substantially larger than the first aspect ratio.

[0007] The first module, for example, may be configured such that the EW width of the first and third panels is substantially equal to the NS width of the second and fourth panel. Accordingly, the first aspect ratio may be approximately one. The second module may be configured such that the EW width of the first and third panel  
15 is substantially larger than the NS width of the second and fourth panel. Accordingly, the second aspect ratio may be substantially larger than one. At least one antenna reflector may be disposed, in a launch configuration, proximate to one of the first panel and the third panel of the second module.

[0008] In an embodiment, a spacecraft may comprise at least two modules, each  
20 module comprising a first panel and a third panel substantially facing, in an on-orbit configuration, respectively, toward north and south and having a width in an east-west direction (EW width); and a second and a fourth panel substantially facing, in the on-orbit configuration, respectively, east and west and having a width in the north-south direction (NS width). Each module has a respective aspect ratio of EW width to NS  
25 width, a first module may be configured with a first aspect ratio, a second module may be configured with a second aspect ratio. The second aspect ratio may be substantially larger than the first aspect ratio. At least one antenna reflector may be disposed, in a launch configuration, proximate to one of the first panel and third panel of the second module.

30 [0009] In a further embodiment, at least one antenna reflector may have a major diameter approximately equal to or greater than the EW width of the first panel of the second module.

[0010] In another embodiment, the first module comprises a launch vehicle mating interface. The launch vehicle mating interface may be disposed, in the on-orbit configuration, facing the Earth.

5 [0011] In a further embodiment, the at least one antenna reflector may be disposed, in the on-orbit configuration, in an easterly or westerly direction with respect to the at least two modules. The at least one antenna reflector may be disposed, in the on-orbit configuration, a substantial distance in the anti-Earth direction from a payload feed element.

10 [0012] In a yet further embodiment, thermal radiators may be disposed on an external surface of at least one of the first panel and the third panel of at least one of the first module and the second module, and at least one antenna reflector may be disposed, in the launch configuration, to at least partially cover the thermal radiators.

15 [0013] In another embodiment, at least one solar array panel may be disposed, during launch, proximate to at least one of the first and third panel of the first module. The at least one solar array panel may be deployed, in the on-orbit configuration, in a northerly or southerly direction with respect to the at least two modules.

[0014] In a further embodiment, the first aspect ratio may be in the range of approximately 0.8 to 1.2, and the second aspect ratio may be least 1.5. Advantageously, the second aspect ratio may be at least three.

20 [0015] In another embodiment, at least two antenna reflectors may be disposed, in the launch configuration, proximate to one of the first panel and third panel of the second module.

### **BRIEF DESCRIPTION OF THE DRAWINGS**

25 [0016] Features of the invention are more fully disclosed in the following detailed description of the preferred embodiments, reference being had to the accompanying drawings, in which:

[0017] FIGS. 1A-D illustrates a satellite configuration of the prior art.

[0018] FIGS. 2A-B illustrates an embodiment of a satellite configured to have multiple aspect ratios.

30 [0019] FIG. 3 illustrates a further embodiment of a satellite configured to have multiple aspect ratios.

[0020] FIG. 4 illustrates an embodiment of a satellite having multiple aspect ratios as configured in an on-orbit configuration.

[0021] FIG. 5 illustrates another embodiment of a satellite configured to have multiple aspect ratios.

5 [0022] FIG. 6 illustrates another embodiment of a satellite configured to have multiple aspect ratios.

[0023] Throughout the drawings, the same reference numerals and characters, unless otherwise stated, are used to denote like features, elements, components, or portions of the illustrated embodiments. Moreover, while the subject invention will now be  
10 described in detail with reference to the drawings, the description is done in connection with the illustrative embodiments. It is intended that changes and modifications can be made to the described embodiments without departing from the true scope and spirit of the subject invention as defined by the appended claims.

#### **DETAILED DESCRIPTION OF THE PREFERRED EMBODIMENTS**

15 [0024] Specific exemplary embodiments of the invention will now be described with reference to the accompanying drawings. This invention may, however, be embodied in many different forms, and should not be construed as limited to the embodiments set forth herein. Rather, these embodiments are provided so that this disclosure will be thorough and complete, and will fully convey the scope of the invention to those  
20 skilled in the art.

[0025] It will be understood that when an element is referred to as being "connected" or "coupled" to another element, it can be directly connected or coupled to the other element, or intervening elements may be present. Furthermore, "connected" or "coupled" as used herein may include wirelessly connected or coupled. As used  
25 herein, the term "and/or" includes any and all combinations of one or more of the associated listed items. The symbol "/" is also used as a shorthand notation for "and/or".

[0026] The terms "spacecraft", "satellite" and "vehicle" may be used interchangeably herein, and generally refer to any orbiting satellite or spacecraft system.

30 [0027] The term "panel" or "panel surface" as used herein, unless otherwise expressly indicated, refers to a substantially planar geometric feature defining an exterior

feature of a spacecraft module. Such a panel or panel surface may not necessarily be structurally contiguous. For example, in an embodiment, a panel may have one or more openings; moreover, a panel surface may be defined by non-structural elements, such as, for example, thermal blankets.

- 5 [0028] The present inventor has recognized that a high capacity spacecraft payload may be achieved by a satellite configured to have multiple aspect ratios, whereby substantially larger spacecraft elements, including north south radiator surfaces, antenna reflectors and solar array panels, may be configured for launch within the launch envelope of conventional launch vehicles. The term “multiple aspect ratio” as  
10 used herein, and in the claims, may be better understood by first referring to FIG. 1 which depicts a satellite configuration of the prior art. Referring to FIG. 1A, an Earth-pointing three axis stabilized satellite 100 is illustrated with respect to a reference spacecraft body coordinate frame 11 having roll (x), pitch (y) and yaw (z) axes. Conventionally, the yaw axis is defined as being directed along a line  
15 intersecting the Earth center of mass and spacecraft center of mass; the roll axis is defined as being perpendicular to the yaw axis, lying in the plane of the orbit in the direction of the spacecraft velocity vector; and the pitch axis (y), normal to the orbit plane, completes a three-axis, right-hand orthogonal system. Satellite 100 has a main body 110 substantially in the form of a rectangular cuboid. A first panel surface 120,  
20 orthogonal to the y-axis faces generally north when the satellite is in an on-orbit configuration, and may be referred to hereinafter as the north panel. A second panel surface 140, orthogonal to the x-axis, may be referred to hereinafter as the east panel. A third panel surface and a fourth panel surface (not shown), disposed opposite, respectively, to north panel 120 and east panel 140 will be referred to hereinafter,  
25 respectively, as the south panel and the west panel. Each of the north and south panels has a first substantially equal width in the east-west direction (EW width); each of the east and west panels has a second substantially equal width in the north-south direction (NS width). The ratio of the EW width of a north/south panel to the NS width of an east/west panel will be referred to herein as the aspect ratio.
- 30 [0029] Satellite main body 110 contains internal payload and bus equipment (not shown) and is structurally coupled to external elements of satellite 100, notably one or more solar arrays 160 and antenna reflectors 180.

[0030] Referring now to FIG. 1B, a launch configuration of satellite 100 is illustrated

in, respectively, elevation view, together with a typical launch vehicle fairing envelope 130. A simplified schematic plan view is illustrated in FIG 1C. It may be observed that, in the launch configuration, solar array 160, and antenna reflectors 180 are disposed proximate to, respectively, north panel 120 and east panel 140.

5 [0031] Because operating internal payload and bus equipment dissipate heat and may be damaged by temperature extremes, such equipment is preferably mounted on a north or south panel. On-orbit, the north or south panels experience a solar radiation exposure that is relatively low and stable compared to the east/west panels which experience significant diurnal cycles as the spacecraft orbits the Earth. As a result, a  
10 higher aspect ratio is preferable for purposes of maximizing equipment mounting area availability on a north/south panel.

[0032] Referring now to FIG 1D, it may be observed that, in the absence of the teachings of the present inventor, increasing the aspect ratio in order to increase equipment mounting area availability on a north/south panel undesirably constrains  
15 the volume available for east/west mounted external components, particularly antenna reflectors 180.

[0033] The present inventor has appreciated that the foregoing problem may be solved by configuring a satellite to have at least two aspect ratios.

[0034] Referring now to FIG. 2, a conceptual view of an embodiment will be  
20 described. Satellite 200 is illustrated in FIG. 2A and 2B in, respectively, elevation and plan views of a launch configuration, together with a typical launch vehicle fairing envelope 230. Satellite body 200 may consist of a first module 212, and a second module 214. In an embodiment, each of module 212 and module 214 may consist of a first panel and a third panel facing, in an on-orbit configuration,  
25 respectively, toward north and south, and having an EW width; and a second panel and a fourth panel facing, in an on-orbit configuration, respectively, east and west, and having a NS width. Advantageously, first module 212 may be configured to have an aspect ratio substantially smaller than the aspect ratio of second module 214. Thus, for example, the EW width of the first and third panel of first module 212 may  
30 be approximately equal to the NS width of the second and fourth panel of first module 212, whereas, the EW width of the first and third panel of second module 214 may be substantially larger than the NS width of the second and fourth panel of second

module 214. In an embodiment, the aspect ratio of the second module may be approximately 3:1.

[0035] In an embodiment, at least one antenna reflector 280 may be disposed, during launch, proximate to one of the first and third panels of second module 214.

5 Advantageously, the large aspect ratio of second module 214 permits antenna reflector 280 to be substantially larger than permitted by conventional satellite configurations. In an embodiment, at least one solar array panel 260 may be disposed during launch, proximate to one of the first and third panel of first module 212.

[0036] As a result of the disclosed multiple aspect ratio configuration, substantially  
10 larger spacecraft elements, including north and south radiator surfaces, antenna reflectors and solar array panels, may be configured for launch within the launch envelope constraints of conventional launch vehicles. For example, where the NS width of the east panel and the west panel of second module 214 is smaller than the NS width of the east panel and west panel of first module 212, volume is made  
15 available within which antenna reflector 280 may be disposed during launch. Advantageously, a major axis of antenna reflector 280 may have a diameter substantially equal to or greater than the EW width of either module. In an embodiment, the EW width of second module 214 may equal or exceed the EW width of first module 212.

20 [0037] Advantageously, thermal radiators may be disposed on the exterior surfaces of north and/or south panels of each of first module 212 and second module 214. In an embodiment one or each of first module 212 and second module 214 may have each of its respective north and south panels thermally interconnected by, for example, crossing heat pipes or thermally conductive straps. Additionally, or alternatively, the  
25 north and/or south panels may be thermally interconnected to an east and/or west panel in a similar manner. Advantageously, panels of first module 212 may likewise be thermally interconnected to panels of second module 214. Because the multiple aspect ratio configuration disclosed herein substantially increases the availability of desirable north/south facing radiator area, the expense and complexity of deployable  
30 thermal radiators may be avoided.

[0038] In a launch configuration antenna reflectors 280 may at least partially cover thermal radiators disposed on north and south panels of module 214.

Advantageously, antenna reflectors 280 may remain in the launch configuration during transfer orbit, thereby effectively reducing the amount of thermal radiator area exposed during transfer orbit, when power generated by the solar arrays is typically limited, and heater power is required to keep the non-operating payload equipment  
5 above a specified minimum temperature. Once on-orbit, antenna reflectors 280 may be deployed as required for the payload operations and also uncover the north and south facing radiators.

**[0039]** In an embodiment, first module 212 may be the lower, or aft, module when the satellite is disposed in the launch configuration, and may incorporate a launch vehicle  
10 mating interface 290. In a first on-orbit configuration, launch vehicle interface 290 may be facing in an anti-Earth direction. In another embodiment, launch vehicle interface 290 may be facing, in a second on-orbit configuration, the Earth. The second on-orbit configuration may be referred to as an “inverted” configuration.

**[0040]** Referring now to FIG. 3, another embodiment will be described, illustrating an  
15 example of use of a multiple aspect ratio configuration in a complex satellite configuration, as it may be disposed in a launch configuration. FIG 3 illustrates an isometric view of satellite 300. In an embodiment, one or more large diameter antenna reflectors 380 may be disposed proximate to north/south panels of module  
20 314. Advantageously, two or more antenna reflectors 380 may be disposed, respectively, proximate to, for example, a north panel of module 314 while an additional two or more antenna reflectors may be disposed proximate to a south panel of module 314. Solar arrays 360 may be disposed proximate to north/south panels of module 312.

**[0041]** Referring now to FIG 4, satellite 300 is illustrated as it may be deployed in an  
25 on-orbit configuration. Each of two solar arrays 360 may be disposed, in the on-orbit configuration, substantially outboard of the satellite, generally extending north and south of, respectively, a north panel and a south panel of module 312. Each antenna reflector 380 may be disposed, in the on-orbit configuration, substantially outboard of the satellite, generally extending in an eastward and westward direction of,  
30 respectively, an east panel and a west panel of module 314. Advantageously, a long antenna focal length may be provided by a deployment mechanism and related structure 482 that also disposes antenna reflectors 380, in the on-orbit configuration, a substantial distance in the anti-earth direction with respect to payload feed elements.

The payload feed elements (not shown) may, advantageously, be disposed on an east/west panel of module 312 or 314.

[0042] Referring now to FIG 5, antenna reflectors 580 may, additionally, be disposed, during launch proximate to an east/west surface of module 212 and/or module 214.

5 [0043] Referring now to FIG. 6, it may be observed that a multiple aspect ratio configuration may be configured to provide three modules, each having a distinct aspect ratio. For example, a first module 612 a second module 614 and a third module 613 may be provided. In an embodiment first module 612 may be a “bus module” comprising mainly non-payload equipment. A third module 613 may  
10 comprise a first payload module and be configured to provide a larger aspect ratio than first module 612. Second module 614, as described above may have a substantially larger aspect ratio than first module 612 or third module 613. In addition to being configured to contain payload equipment and have north south panels with thermal radiators, second module 614 may be configured to provide  
15 volume outboard of and proximate to the north and south panels, within which large diameter antenna reflectors (not shown) may be disposed.

[0044] Although the embodiments described above relate to modules configured as rectangular cuboids having four panel surfaces oriented, respectively, north, south, east, and west, the teachings of the present disclosure are not so limited. A spacecraft  
20 configuration with multiple aspect ratios in accordance with the present invention may be accommodated by spacecraft modules having, for example, six or eight panels.

[0045] Thus, a high capacity satellite has been disclosed, wherein a multiple aspect ratio configuration provides substantial advantages over the prior art, including, but  
25 not limited to enabling increased thermal radiator area, and larger diameter antenna reflectors while complying, in a launch configuration, with the constraints of conventional launch vehicle fairings.

What is claimed is:

1. A spacecraft, comprising:
  - at least two modules, each said module comprising:
    - a first panel and a third panel substantially facing, in an on-orbit configuration,  
5 respectively, toward north and south and having a width in an east-west direction (EW width); and a second and a fourth panel substantially facing, in the on-orbit configuration, respectively, east and west and having a width in the north-south direction (NS width), wherein:
      - each said module has a respective aspect ratio of EW width to NS width;
      - 10 a first module is configured with a first aspect ratio;
      - a second module is configured with a second aspect ratio; and
      - the second aspect ratio is substantially larger than the first aspect ratio.
2. The spacecraft according to claim 1, wherein the at least one antenna reflector is disposed, in a launch configuration, proximate to one of the first panel and third panel  
15 of the second module.
3. The spacecraft according to claim 1, wherein the at least one antenna reflector has a major diameter approximately equal to or greater than the EW width of the first panel of the second module.
4. The spacecraft according to claim 1, wherein the first module comprises a launch  
20 vehicle mating interface.
5. The spacecraft according to claim 4, wherein the launch vehicle mating interface is disposed, in the on-orbit configuration, facing the Earth.
6. The spacecraft according to claim 1, wherein the at least one antenna reflector is disposed, in the on-orbit configuration, in an easterly or westerly direction with  
25 respect to the at least two modules.
7. The spacecraft according to claim 6, wherein the at least one antenna reflector is disposed, in the on-orbit configuration, a substantial distance in the anti-Earth direction from a payload feed element.

8. The spacecraft according to claim 1, wherein thermal radiators are disposed on an external surface of at least one of the first panel and the third panel of at least one of the first module and the second module, and at least one antenna reflector is disposed, in the launch configuration, to at least partially cover the thermal radiators.
- 5 9. The spacecraft according to claim 1, wherein at least one solar array panel is disposed, during launch, proximate to at least one of the first and third panel of the first module.
- 10 10. The spacecraft according to claim 9, wherein the at least one solar array panel is deployed, in the on-orbit configuration, in a northerly or southerly direction with respect to the at least two modules.
11. The spacecraft according to claim 1, wherein the first aspect ratio is in the range of approximately 0.8 to 1.2 and the second aspect ratio is at least 1.5.
12. The spacecraft according to claim 11, wherein the second aspect ratio is at least three.
- 15 13. The spacecraft according to claim 1 wherein at least two antenna reflectors are disposed, in the launch configuration, proximate to one of the first panel and third panel of the second module.

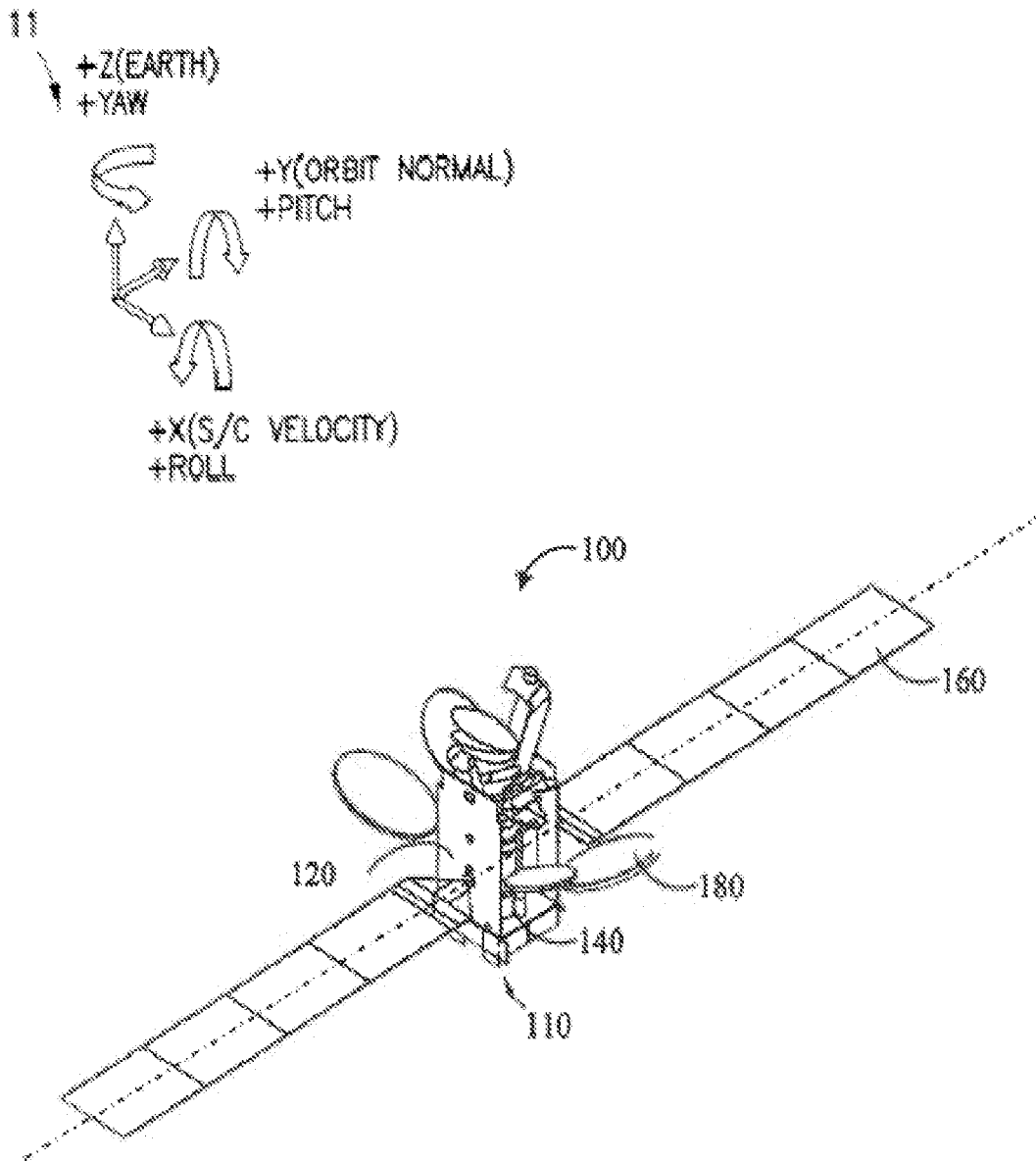

FIG. 1A—Prior Art

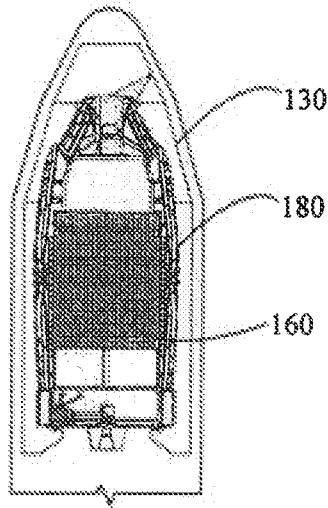

FIG. 1B—PRIOR ART

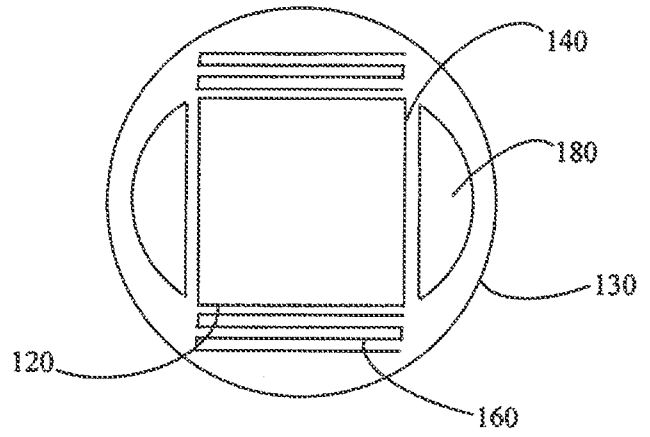

FIG. 1C—PRIOR ART

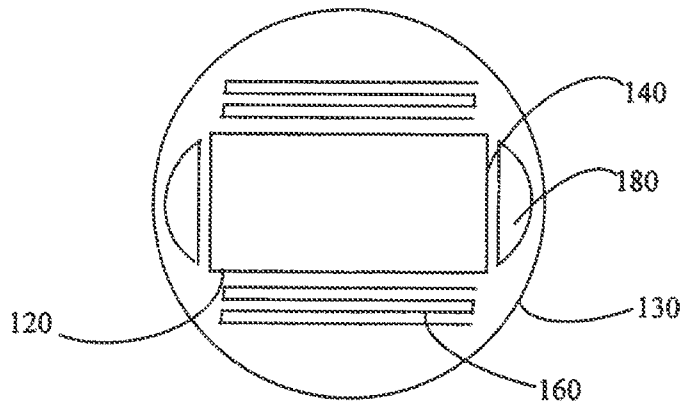

FIG. 1D—PRIOR ART

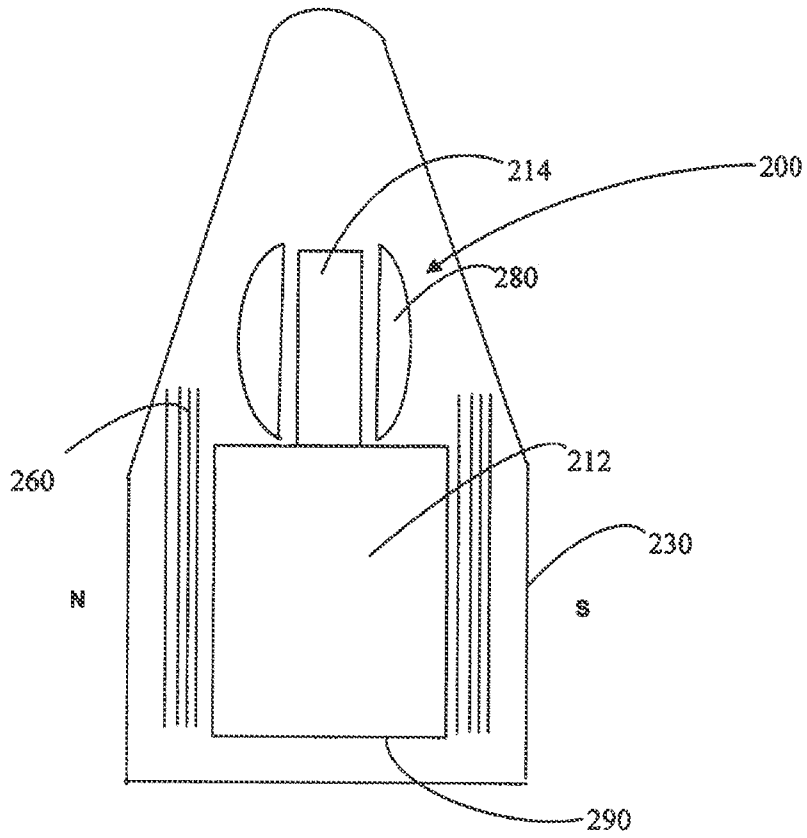

FIG. 2A

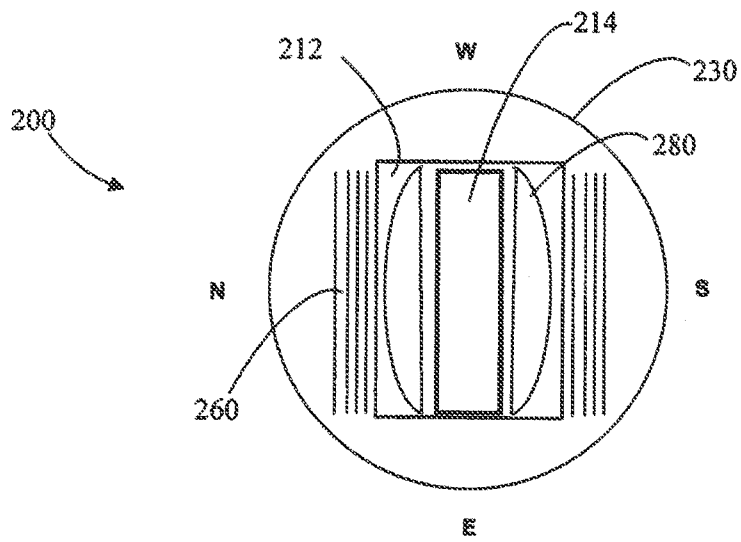

FIG. 2B

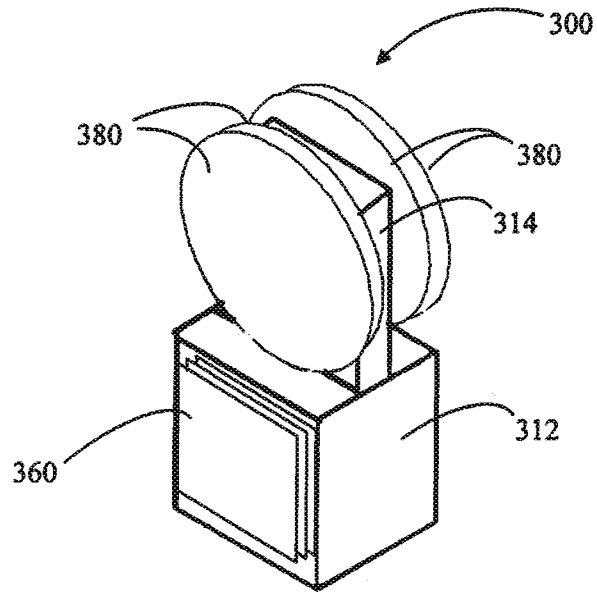

FIG. 3

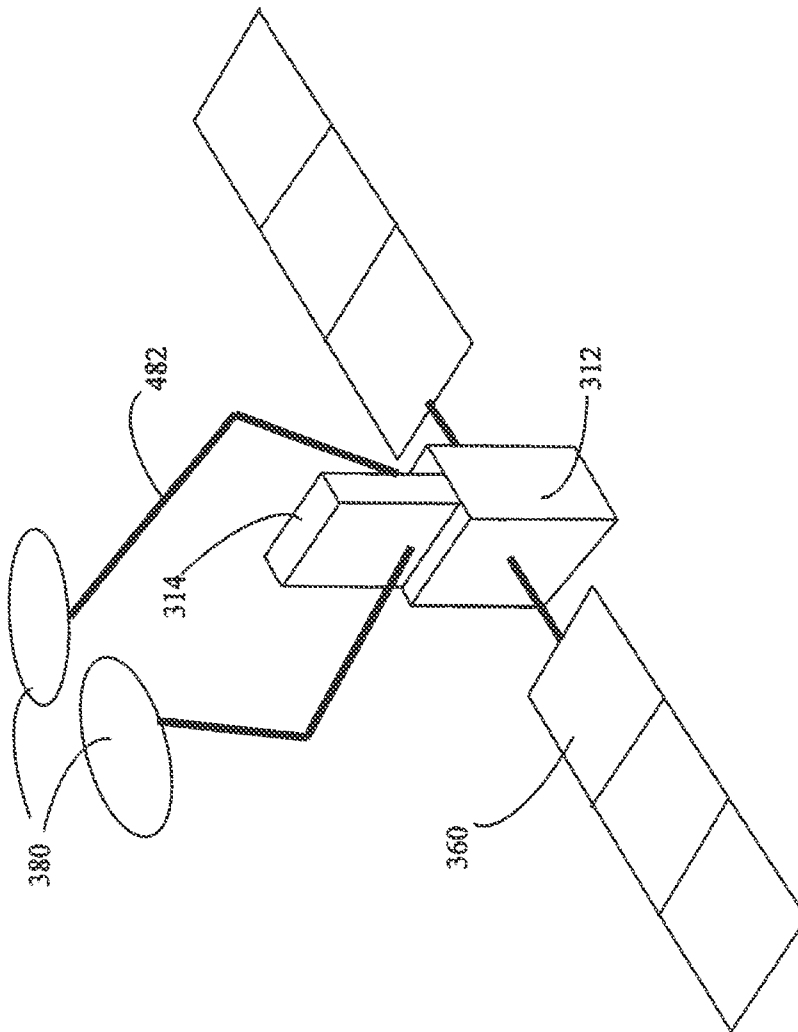

FIG. 4

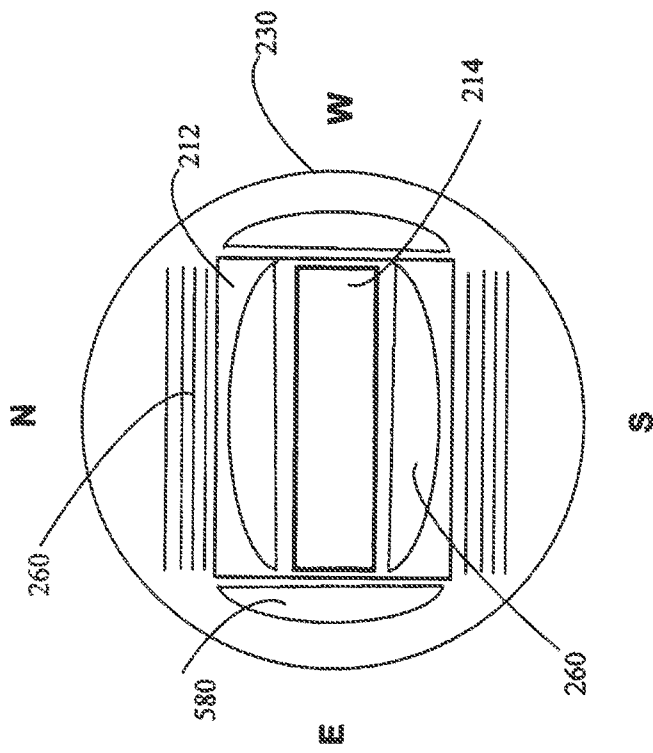

FIG. 5

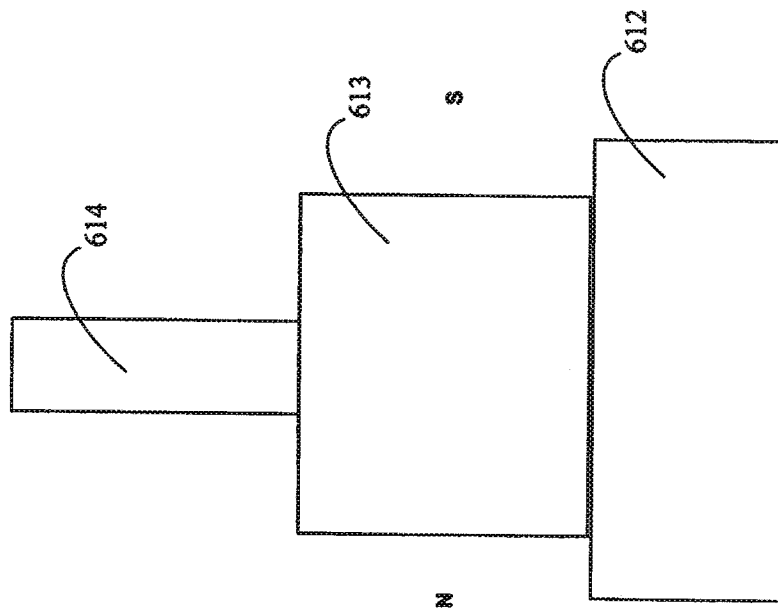

FIG. 6

**INTERNATIONAL SEARCH REPORT**

International application No  
PCT/US2011/049190

**A. CLASSIFICATION OF SUBJECT MATTER**  
 INV. B64G1/10      B64G1/22      B64G1/44      B64G1/58  
 ADD.

According to International Patent Classification (IPC) or to both national classification and IPC

**B. FIELDS SEARCHED**

Minimum documentation searched (classification system followed by classification symbols)  
 B64G

Documentation searched other than minimum documentation to the extent that such documents are included in the fields searched

Electronic data base consulted during the international search (name of data base and, where practical, search terms used)  
 EPO-Internal, WPI Data

**C. DOCUMENTS CONSIDERED TO BE RELEVANT**

Category*	Citation of document, with indication, where appropriate, of the relevant passages	Relevant to claim No.
X	EP 0 780 294 A2 (HUGHES AIRCRAFT CO [US] HUGHES ELECTRONICS CORP [US]) 25 June 1997 (1997-06-25) column 3, line 39 - line 52 column 4, line 31 - line 34 column 6, line 46 - line 51; figures 1-4,12	1-13
X	FR 2 476 018 A1 (ORG EUROPEENE DE RECH [FR]) 21 August 1981 (1981-08-21) page 8, line 16 - page 9, line 15; figure 4	1-3,6,7, 11,12
X	FR 2 522 614 A1 (CENTRE NAT ETD SPATIALES [FR]) 9 September 1983 (1983-09-09) page 3, line 20 - page 4, line 27; figure 2	1-3,6,13
	----- -/--	

Further documents are listed in the continuation of Box C.

See patent family annex.

\* Special categories of cited documents :

<p>"A" document defining the general state of the art which is not considered to be of particular relevance</p> <p>"E" earlier document but published on or after the international filing date</p> <p>"L" document which may throw doubts on priority claim(s) or which is cited to establish the publication date of another citation or other special reason (as specified)</p> <p>"O" document referring to an oral disclosure, use, exhibition or other means</p> <p>"P" document published prior to the international filing date but later than the priority date claimed</p>	<p>"T" later document published after the international filing date or priority date and not in conflict with the application but cited to understand the principle or theory underlying the invention</p> <p>"X" document of particular relevance; the claimed invention cannot be considered novel or cannot be considered to involve an inventive step when the document is taken alone</p> <p>"Y" document of particular relevance; the claimed invention cannot be considered to involve an inventive step when the document is combined with one or more other such documents, such combination being obvious to a person skilled in the art.</p> <p>"&amp;" document member of the same patent family</p>
--	--

Date of the actual completion of the international search  9 January 2012	Date of mailing of the international search report  17/01/2012
Name and mailing address of the ISA/ European Patent Office, P.B. 5818 Patentlaan 2 NL - 2280 HV Rijswijk Tel. (+31-70) 340-2040, Fax: (+31-70) 340-3016	Authorized officer  Kaysan, Rainer

## INTERNATIONAL SEARCH REPORT

International application No  
PCT/US2011/049190

C(Continuation). DOCUMENTS CONSIDERED TO BE RELEVANT		
Category*	Citation of document, with indication, where appropriate, of the relevant passages	Relevant to claim No.
X	RU 2 092 398 C1 (N PROIZV OB EDINENIE PRIKLADNO [SU]) 10 October 1997 (1997-10-10) abstract; figures 1,7 -----	1

# INTERNATIONAL SEARCH REPORT

Information on patent family members

International application No

PCT/US2011/049190

Patent document cited in search report	Publication date	Patent family member(s)	Publication date
EP 0780294	A2	25-06-1997	DE 69627796 D1 05-06-2003
			DE 69627796 T2 18-03-2004
			EP 0780294 A2 25-06-1997
			US 5755406 A 26-05-1998
-----			
FR 2476018	A1	21-08-1981	FR 2476018 A1 21-08-1981
			JP 56131498 A 15-10-1981
			US 4384692 A 24-05-1983
-----			
FR 2522614	A1	09-09-1983	FR 2522614 A1 09-09-1983
			US 4508297 A 02-04-1985
-----			
RU 2092398	C1	10-10-1997	NONE
-----			