



US 20050236149A1

(19) **United States**

(12) **Patent Application Publication**

Geskes et al.

(10) **Pub. No.: US 2005/0236149 A1**

(43) **Pub. Date: Oct. 27, 2005**

(54) **HEAT EXCHANGER**

(30) **Foreign Application Priority Data**

(75) Inventors: **Peter Geskes**, Stuttgart (DE);
Christoph Walter, Stuttgart (DE);
Karl-Heinz Staffa, Stuttgart (DE)

Aug. 13, 2002 (DE)..... 102 37 648.4

Publication Classification

Correspondence Address:
FOLEY AND LARDNER
SUITE 500
3000 K STREET NW
WASHINGTON, DC 20007 (US)

(51) **Int. Cl.⁷** **F28F 9/02**
(52) **U.S. Cl.** **165/177; 165/173**

(57) **ABSTRACT**

(73) Assignee: **BEHR GmbH & CO. KG**, D-70469
Stuttgart (DE)

The aim of the invention is to provide a light and especially simple heat exchanger comprising a number of parallel, interspaced flat tubes. To this end, the flat tubes (2) can be supplied with a fluid (F) via at least one end (8) by means of a manifold (6), said flat tubes (2) being arranged in the manifold (6) in an at least partially positively locking manner.

(21) Appl. No.: **10/524,408**

(22) PCT Filed: **Aug. 7, 2003**

(86) PCT No.: **PCT/EP03/08778**

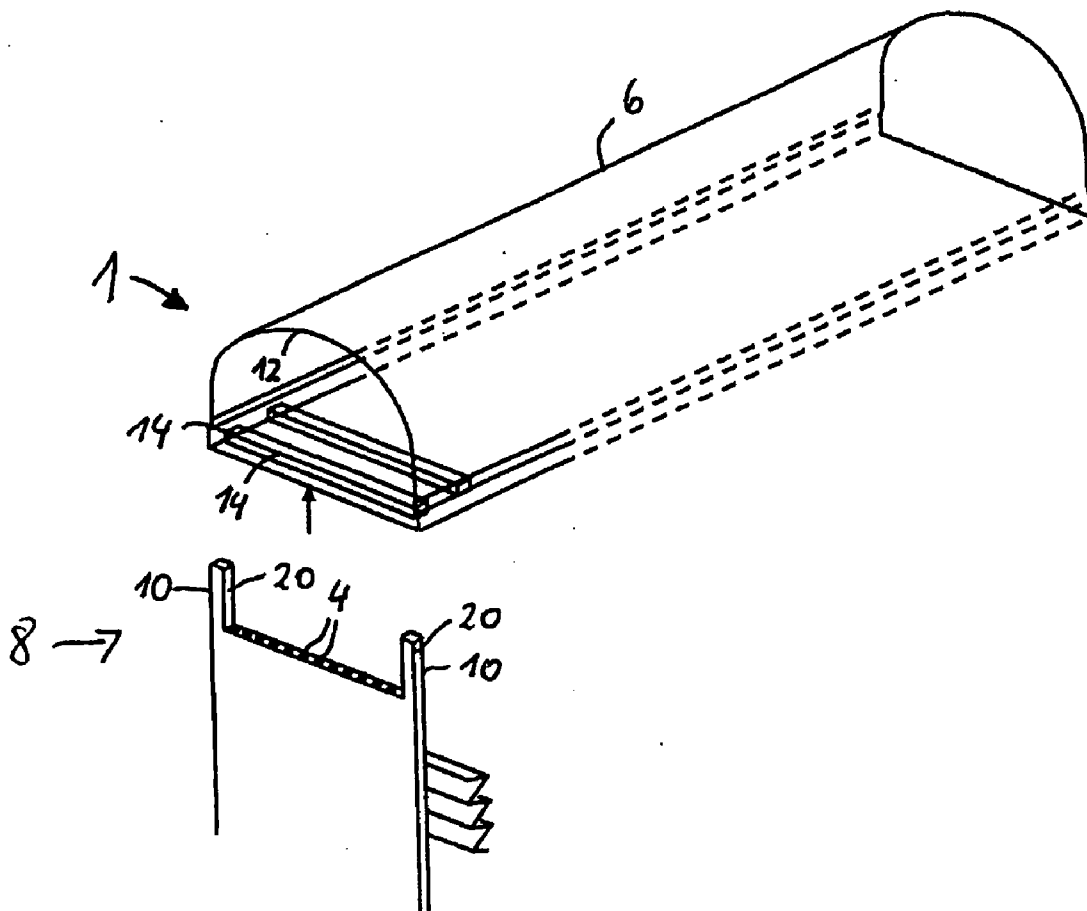

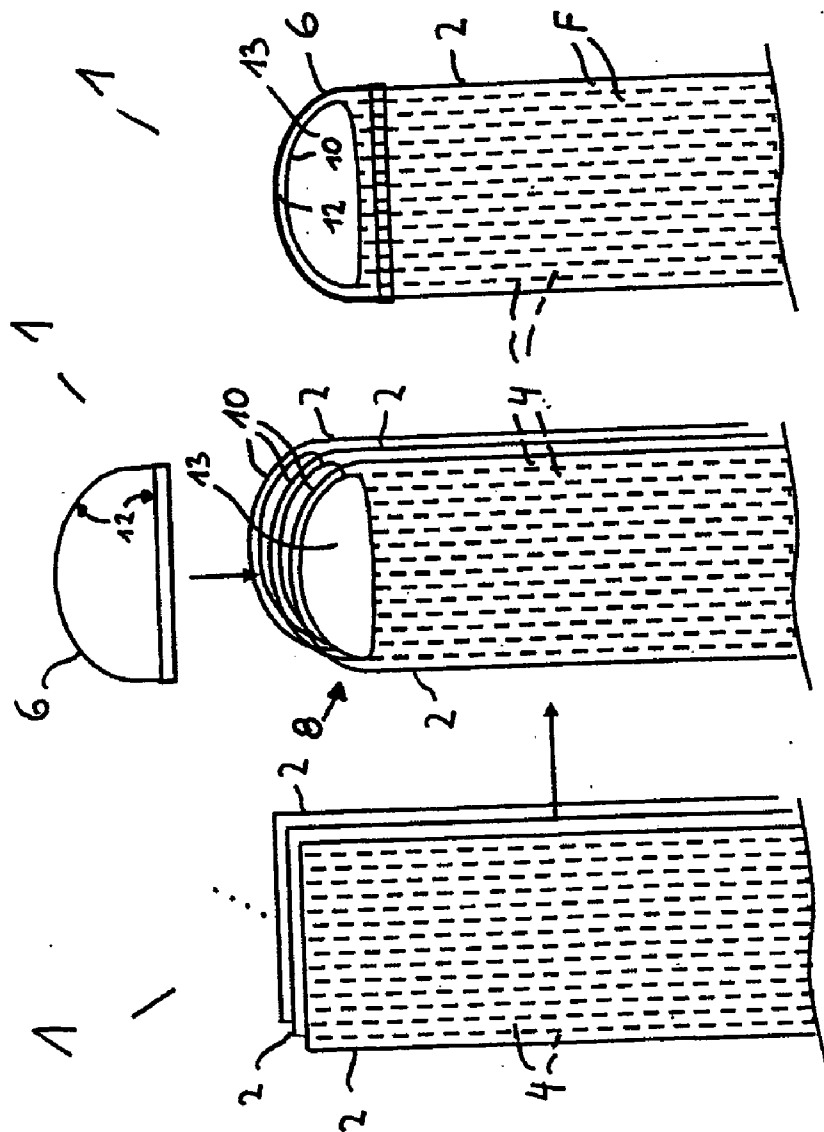

Fig. 1C

Fig. 1B

Fig. 1A

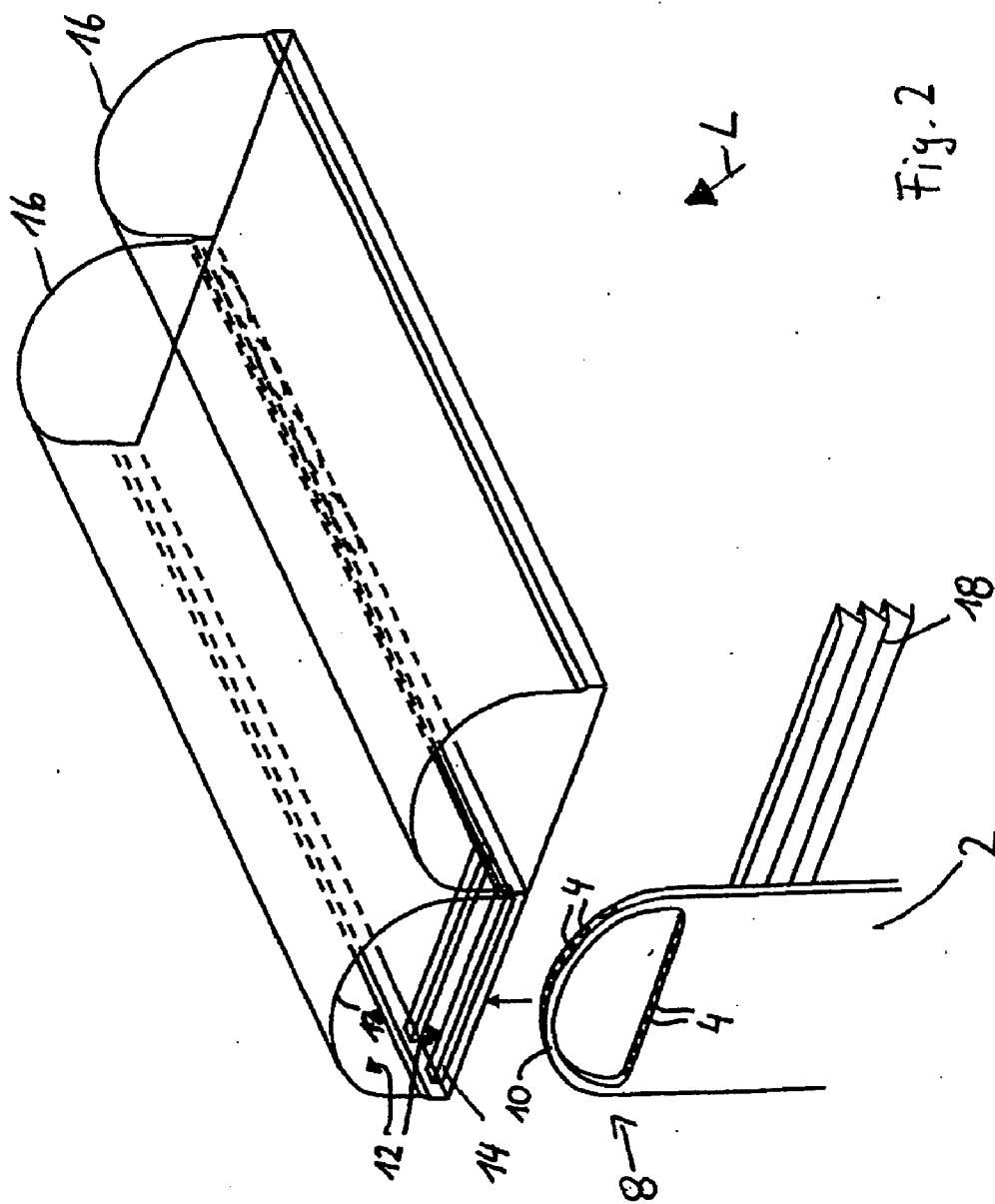

Fig. 2

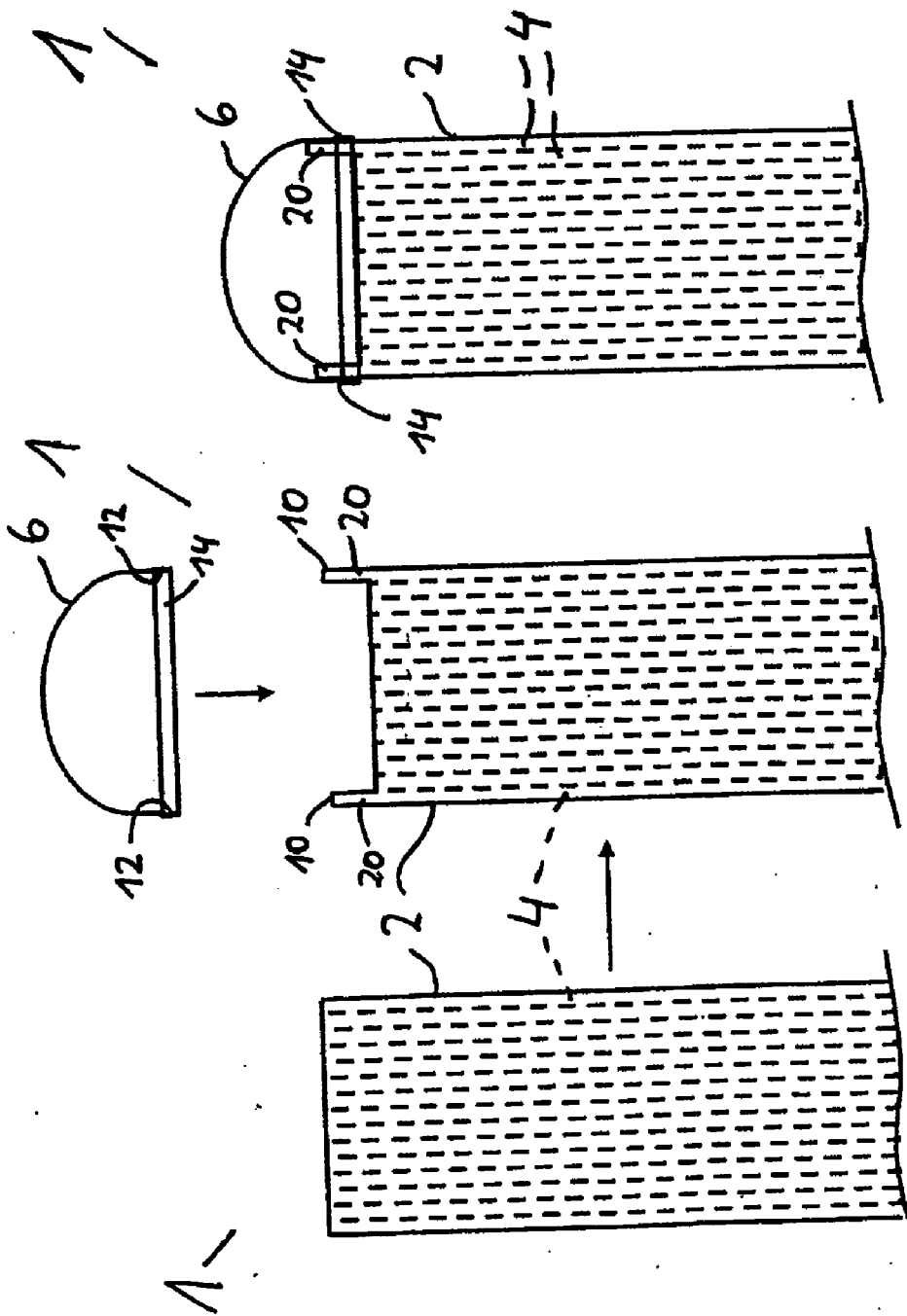
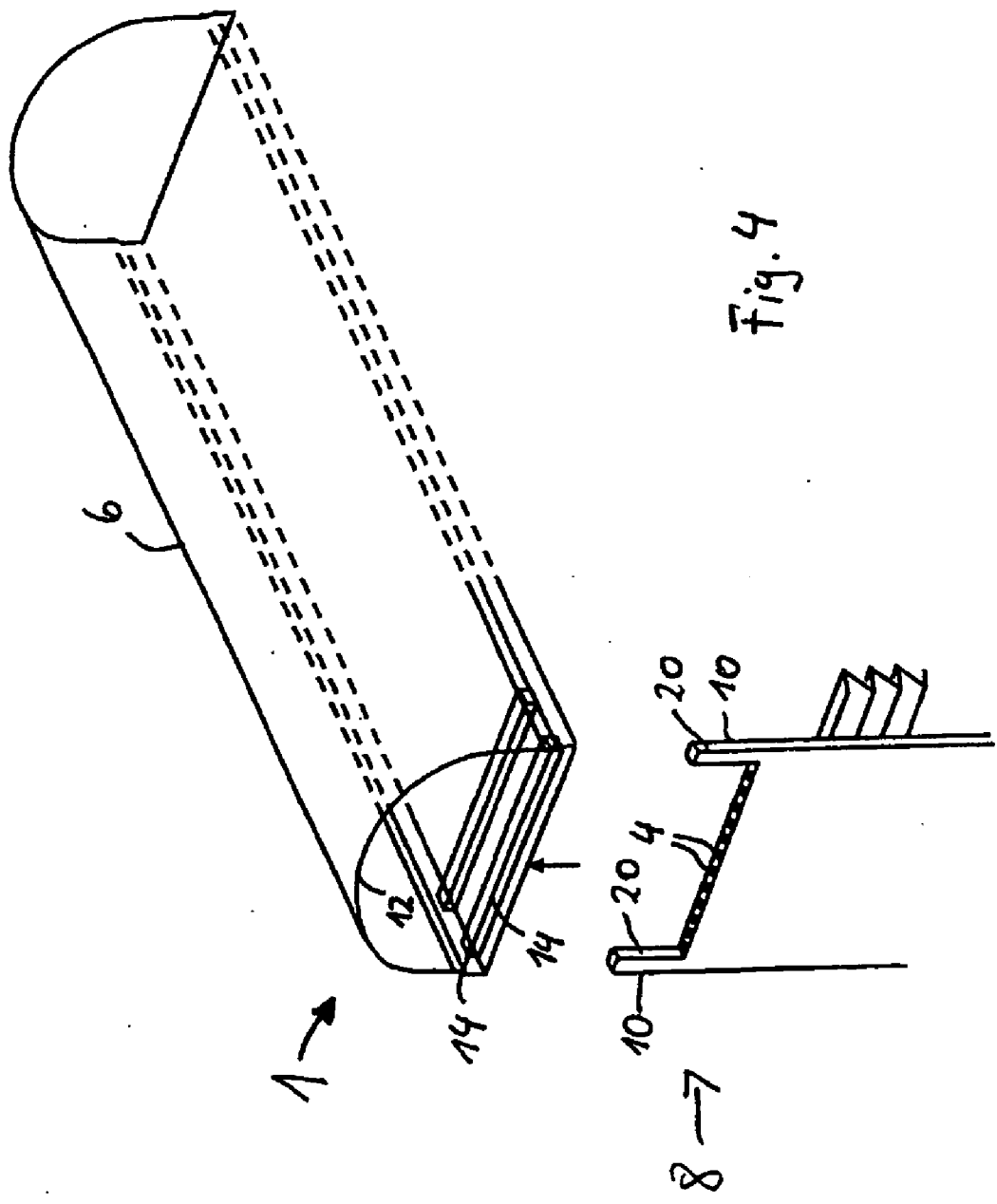

Fig. 3C

Fig. 3B

Fig. 3A



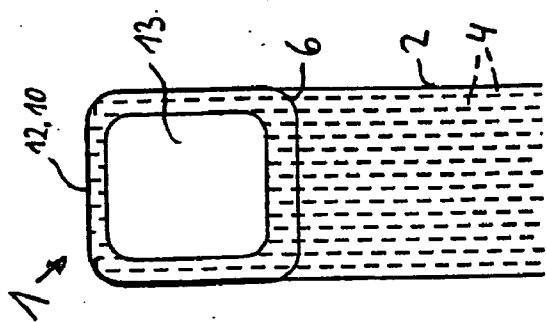

Fig. 6B

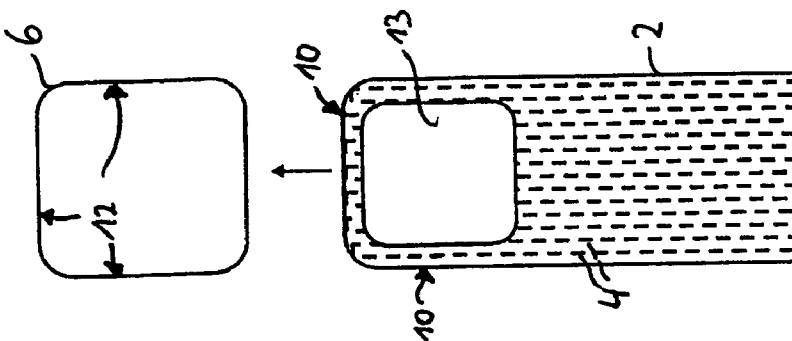

Fig. 6A

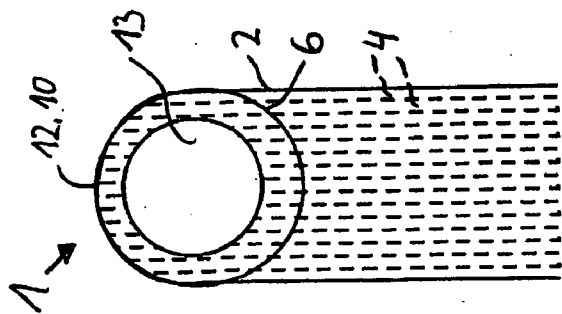

Fig. 5B

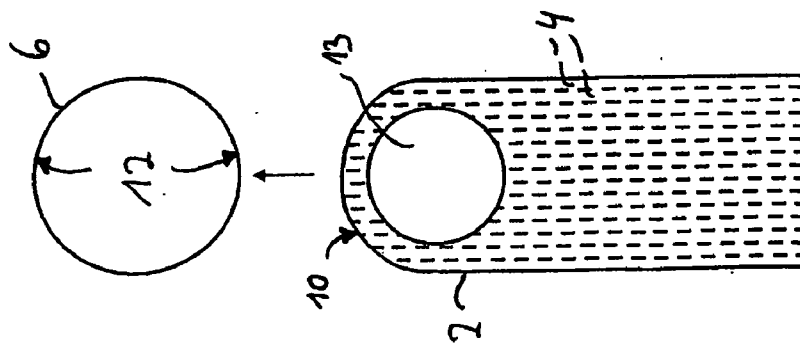
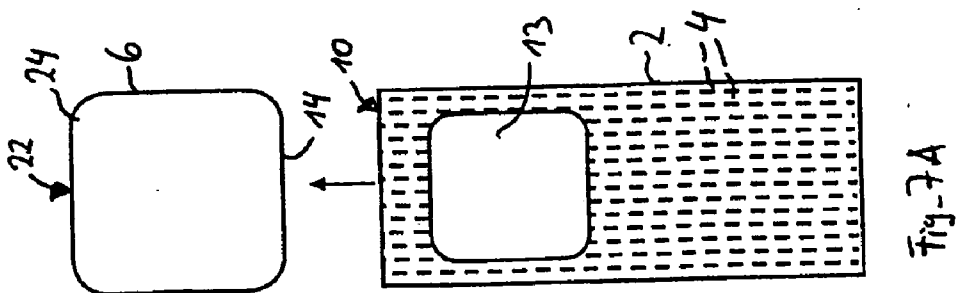
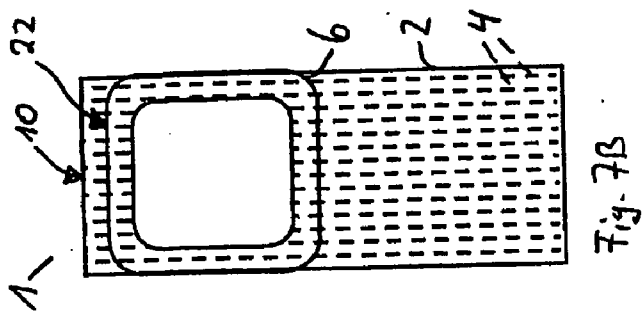
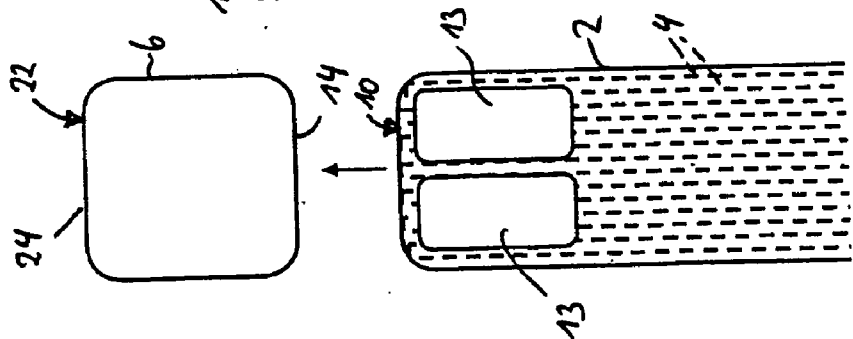
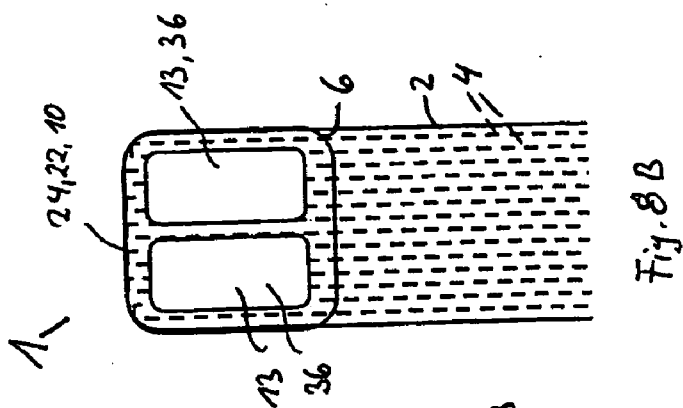
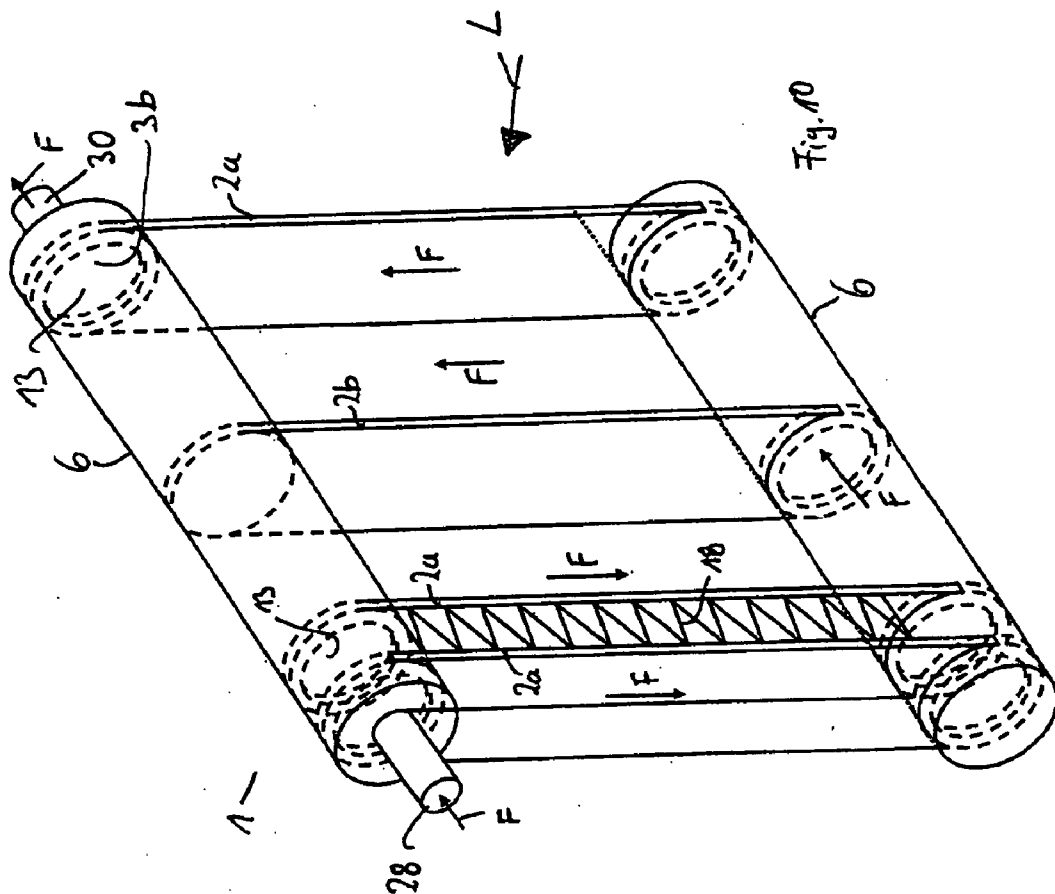

Fig. 5A





HEAT EXCHANGER

[0001] The invention relates to a heat exchanger having a number of flat tubes arranged parallel to and at a distance from one another, in particular for an air-conditioning system of a vehicle.

[0002] Nowadays, it is customary for heat exchangers which release heat from a fluid flowing through them on the primary side, e.g. carbon dioxide, water or refrigerant, to air flowing through the heat exchanger on the secondary side, to be used in vehicles. Conversely, the fluid flowing through the heat exchanger may absorb heat from the air. For this purpose, the heat exchanger in particular has flat tubes which are parallel to and at a distance from one another. Fins or reinforcing webs are arranged between the flat tubes in order to make the heat exchanger sufficiently strong and stable in particular with respect to mechanical loads.

[0003] To provide a common feed of the fluid to the flat tubes, their end sides are connected to what are known as collection boxes or collection manifolds. In this case, the fluid, which is in the form of a coolant or refrigerant, flows through passages running in the flat tubes and is then collected in the collection boxes or tubes and if appropriate diverted into adjacent flat tubes of the heat exchanger. For this purpose, it is customary for the collection boxes to have partition walls.

[0004] A heat exchanger of this type having flat tubes with so-called capillaries or small passages passing through them, which are fed via the collection box, is known, for example, from EP 0 654 645 B1.

[0005] The flat tubes have the advantage that very small passages, also known as cooling or fluid passages, can be provided, which are particularly pressure-stable. As a result, the collection box or collection manifold which performs a fluid collection and/or distribution function has to be designed with a particularly large volume. The heat exchanger has to withstand a particularly high internal pressure, with the rupture pressure, as it is known, being well above the maximum permissible operating pressure. Therefore, when designing and constructing the heat exchanger, it is ensured, with regard to its maximum permissible resistance to pressure, that in particular the collection box or collection tube has a sufficient wall thickness. In particular when the heat exchanger is used for an air-conditioning circuit containing carbon dioxide or the fluid known as R 134 A as cooling medium, the high pressures which are customary in such applications mean that the heat exchanger and its collection box have very thick-walled collection tubes or collection manifolds with in some cases pronounced beads. One drawback in this context is that high levels of materials are deployed, in particular in the region of the collection box, on account of the very thick walls required, and this makes the soldering of the flat tubes to the collection box particularly time-consuming. Furthermore, a heat exchanger designed in this manner is particularly expensive and also subject to restrictions on the freedom of design, in particular for the collection box on which it is based. Furthermore, the weight of a heat exchanger designed in this manner is particularly high.

[0006] Therefore, the invention is based on the object of providing a heat exchanger, in particular for an air-conditioning system of a vehicle, which is of particularly simple design and has a low weight.

[0007] According to the invention, the object is achieved, in the case of a heat exchanger having a number of flat tubes which are arranged parallel to and spaced apart from one another and via at least one end can be fed with a fluid via a collection manifold, the flat tubes in the collection manifold being arranged at least partially in a positively locking manner.

[0008] In this context, the invention is based on the consideration that a design of a collection box or collection manifold which is particularly thick-walled for flat tubes, through which a fluid, in particular cooling medium, can flow, of a heat exchanger, on account of considerable differences in mechanical loads, should be dimensioned in such a way as to be of particularly simple and lightweight design. Furthermore, the flat tubes which open out and are held in the collection manifold should at the same time allow the collection manifold to be reinforced, so that the latter is additionally made pressure-resistant or pressure-stable by means of the design or shape of the ends of the flat tubes. For this purpose, the flat tubes are preferably arranged at least partially in a positively-locking manner in the collection manifold. In particular, the flat tubes are routed substantially completely within the collection manifold, so that in addition to a positive lock they are also able to incorporate a non-positive lock, in particular are able to absorb tensile and/or compressive forces.

[0009] For the flat tubes to be as far as possible in a completely positively locking position in the collection manifold where they are held, an outer contour, which represents the end of the respective flat tube, is at least partially matched to an internal contour which represents the collection manifold. On account of this arrangement of the flat tubes in the collection manifold, which utilizes the entire periphery of the collection box or tube, the flat tubes are arranged in the style of tie rod or connecting anchor in the heat exchanger.

[0010] In an alternative embodiment of the heat exchanger, in particular the flat tubes thereof, it is preferable for an outer contour, which represents the end of the respective flat tube, to be at least partially matched to an outer contour which represents the collection manifold. As an alternative to the external contour of the flat tube being matched to the internal contour of the collection manifold, the corresponding flat tube can also be inserted into the heat exchanger and thereby mounted from the outside if at least one end of the flat tube is matched to the external contour of the collection manifold. For this purpose, it is expedient for the collection manifold to be provided with at least one cutout for one of the flat tubes to pass through. The cutout is designed to receive the flat tube, in particular as a slot-like cutout. It is expedient for the end of the corresponding flat tube to be held cohesively at the cutout of the collection manifold. By way of example, the end of the flat tube is compressed or squeezed and soldered to the collection manifold in the cutout therein. Soldering the flat tubes to the collection manifold from the outside in this way ensures that the heat exchanger is sufficiently leaktight with respect to the fluid flowing through it, so that humidification of the air which flows through the heat exchanger on the secondary side is reliably avoided.

[0011] To increase the rigidity and compressive strength of the heat exchanger, one end of at least one of the flat tubes

is provided with webs on the outer side. As an alternative to a half-profile design of the flat tube end of this type, the flat tube may at its end side serve as a completely encircling reinforcement and support for the collection manifold or collection tube.

[0012] For this purpose the end of the corresponding flat tube is provided with an opening or cutout. A frame-like design of the end of the respective flat tube of this type as a result of an encircling frame or an encircling profile or as a result of a half-frame or half-profile in the form of webs allows a suitable reinforcement or compressive strength of the heat exchanger to be set according to the specific use of the heat exchanger. When producing this type of flat tubes provided with an opening or flat tubes having webs on the outer sides, the opening or webs is/are formed by stamping, perforating or water jet processes. At the same time, the perforation opening or the opening formed by webs serves to supply the fluid, in particular to allow coolant or refrigerant to pass through into the capillaries or passages in the flat tube which have been opened up by the opening. In this case, the bores or capillaries which run within the respective flat tube are fed by means of the fluid routed in the opening of the flat tube end. In other words: an annular (=stamped-out opening) or U-shaped end (=laterally punched-out webs) of the flat tubes of this nature, which, by means of the respective end, are arranged in a completely or at least partially positively locking manner in the collection manifold, in each case itself forms part of the collection or manifold passage of the collection manifold for feeding and/or discharging the fluid. In a further alternative embodiment, the end of at least one of the flat tubes is provided with a further, centrally arranged web. Depending on the extent to which the flat tube is introduced into the collection manifold, it is possible to form a collection manifold which is split in two by means of an end, which has two outer and one central webs, of the flat tube when the latter is completely introduced and therefore connected in a completely positively locking manner to the collection manifold in a particularly simple way, it being possible for one chamber formed by this division in two to be used to supply the fluid and the other chamber to be used to discharge the fluid. Alternatively, if the chambers of a collection manifold which has been divided in this way are fed in the same direction, it is possible for a plurality of flat tubes which have been combined to form a group to be fed separately from one another, thereby allowing different types of flow through the heat exchanger.

[0013] For substantially accurate positioning of the flat tubes in the collection manifold, the end of the respective flat tube is preferably at least partially routed in a recess which runs within the internal contour. By way of example, on the inner side the collection manifold has a channel-like bead or a groove in which the end of the respective flat tube is guided and fitted. As a result, in addition to a particularly flush and positively locking arrangement of the flat tubes in the collection manifold, sufficiently strong fixing of the flat tubes is also possible.

[0014] For the flat tube to be arranged in a pressure- and/or tension-resistant manner in the collection manifold, it is expedient for the end of the respective flat tube to be held in a positively locking manner at the collection manifold. By way of example, the end of the respective flat tube is held at the collection manifold with or without filler material. In a

preferred embodiment, the end of the flat tube is soldered along the recess of the collection manifold. As an alternative or in addition, the end of the respective flat tube may be adhesively bonded or welded.

[0015] For a differentiated feed of the fluid to the heat exchanger, e.g. in cross-countercurrent or in cross-cocurrent, it is expedient for the collection manifold to be longitudinally and/or transversely divided into at least two regions. It is preferable for the collection box or collection manifold to be divided two or more times. For this purpose, a partition wall is arranged in the collection manifold, depending on the type and design of the heat exchanger. It is expedient for the end of at least one of the flat tubes to be provided with a slot for receiving the partition wall. To achieve a variable setting of the fluid flowing through the heat exchanger, it is expedient for the partition wall to have a through-opening. In a particularly simple and inexpensive design of the heat exchanger for different types of flow through it, the ends of the flat tubes are designed differently. By way of example, a number of flat tubes which are arranged adjacent to one another are provided, at least at one end, with the annular and/or U-shaped through-opening for the fluid, while a next flat tube is designed as a solid profile, and therefore without any punched openings, at the end side, so that it performs the function of a partition wall. This eliminates the need to introduce additional partition walls. This further simplifies the design of the heat exchanger compared to the prior art.

[0016] Depending on the type and design of heat exchanger, it is possible for the flat tubes to open out into an associated collection manifold at each of their end sides. In this case, the flat tubes may be fed from one or both sides, i.e. if the flat tubes are fed from one side, by way of example, a collection manifold which is divided in two and has a chamber for supplying the fluid and a further chamber for discharging the fluid is arranged at one end of the flat tubes. If the flat tubes are fed from both sides, an individual collection manifold is provided at one end side for feeding the fluid and an individual collection manifold is provided at the other side for discharging the fluids. As an alternative or in addition, in the case of a U-shaped flow of the fluid through the heat exchanger, one of the collection manifolds may serve as a feed and discharge, and the opposite collection manifold may serve as a diverter passage for diverting the fluid between two adjacent flat tubes. It is preferable for the collection manifolds arranged at the end sides of the flat tubes to be of identical design. This ensures sufficiently strong and uniform flow of the fluid through the flat tubes.

[0017] The advantages which are achieved with the present invention consist in particular in the fact that as a result of a positively locking arrangement of the flat tubes in the collection manifold or collection tube, in particular as a result of a complete positive lock in the peripheral direction of the collection manifold, the latter is designed with significantly reduced wall thicknesses. A positively locking arrangement of the flat tubes in the collection manifold of this nature causes tensile and/or compressive forces acting on the heat exchanger to be dissipated into the flat tubes in the manner of a tie rod or connecting anchor. Furthermore, flat tubes of this type which are inserted until they butt against or are flush inside the collection manifold are particularly simple to fit and easy to handle. Soldering of the flat tubes, which in each case have an open (=annular) or semi-open (=U-shaped) or closed end, to the internal contour

and/or external contour of the collection manifold additionally reinforces the collection manifold and therefore the heat exchanger, in the style of reinforcing fins. Furthermore, flat tubes thus arranged in a positively locking and/or cohesive manner make it possible to dispense with the need for additional partition walls for diverting the coolant or refrigerant, since on account of the flat tubes being designed differently at the end sides, with and/or without an opening or cutout, these flat tubes themselves form partition walls for diverting the coolant or refrigerant. As a result, in addition to the heat exchanger being of particularly lightweight design, the costs relating to the amount of material required are also considerably reduced.

[0018] Exemplary embodiments of the invention are explained in more detail with reference to a drawing, in which:

[0019] FIGS. 1A-1C diagrammatically depict a heat exchanger having a plurality of flat tubes arranged in a positively locking manner in a collection manifold,

[0020] FIG. 2 diagrammatically depicts a heat exchanger with a split collection box,

[0021] FIGS. 3A-3C diagrammatically depict a heat exchanger with flat tubes provided with webs at the end side,

[0022] FIG. 4 diagrammatically depicts a perspective illustration of a heat exchanger as shown in FIGS. 3A-3C,

[0023] FIGS. 5A-5B and 6A-6B diagrammatically depict various heat exchangers with collection manifolds that have different cross-sectional shapes,

[0024] FIGS. 7A-7B diagrammatically depict a heat exchanger with flat tubes introduced from the outside,

[0025] FIGS. 8A-8B diagrammatically depict a heat exchanger with flat tubes that have two openings,

[0026] FIG. 9 diagrammatically depicts a heat exchanger having a partition wall, provided for different forms of through-flow, in the collection manifold, and

[0027] FIG. 10 diagrammatically depicts a heat exchanger with two collection manifolds arranged at the end sides of the flat tubes.

[0028] Corresponding parts are provided with identical reference symbols throughout all the figures.

[0029] FIGS. 1A to 1C show a heat exchanger arrangement 1 having a number of flat tubes 2 which are arranged parallel to and at a distance from one another. The flat tubes 2 are provided with fluid passages 4 for a fluid F, e.g. a stream of coolant or refrigerant for an air-conditioning system of a vehicle, to flow through. The fluid passages 4 have a particularly small diameter and are designed in the form of capillaries. The fluid passages 4 of the respective flat tubes 2 can be fed with the fluid F via a collection manifold 6. To achieve a heat exchanger 1 which is as simple as possible and has a particularly low weight, the flat tubes 2 are arranged at least partially in a positively locking manner in the collection manifold 6. For this purpose, the end 8 of the respective flat tube 2 and an external contour 10 which represents this end 8 are matched to an internal contour 12 which represents the collection manifold 6.

[0030] To achieve a particularly thin-walled and therefore material-saving design of the collection manifold 6, the end

8 of at least one of the flat tubes 2 is provided with an opening 13 (FIG. 1B). A frame-like, e.g. annular, design of the flat tube end 8 of this type allows a completely positively locking connection between the external contour 10 and the internal contour 12 of the collection manifold 6 combined with sufficient protection of the latter with respect to the mechanical stresses by means of a reinforcement and support which substantially completely surrounds the collection manifold 6. This leads to a particularly thin-walled design of the collection manifold 6. The opening 13 formed at the end 8 of the respective flat tube 2 itself serves as a flow passage of the collection manifold 6 for supplying and/or discharging the fluid F. Depending on the design of the flat tubes 2, the opening 13 may be produced by perforating, stamping, drilling or in some other suitable way. For example, in the case of flat tubes 2 which have already been joined to one another and form a component of the heat exchanger 1, and which are of identical design in terms of the opening 13, the opening 13 may be formed in a single process step by stamping or perforation. As an alternative, in the case of flat tubes 2 of a single heat exchanger 1 through which flow passes in different ways and which are of different designs at the end side, i.e. with and/or without opening 13, the flat tubes 2 may be produced separately or in groups.

[0031] FIG. 2 shows an alternative heat exchanger 1 having a flat tube 2, the external contour of the end 8 of which is matched to the internal contour 12 of the collection manifold 6. For reliable positioning, the end 8 of the respective flat tube 2 is at least partially routed in a recess 14, running within the internal contour 12, of the collection manifold 6. Depending on the type and design of recess 14, the latter may be designed as channel-like bead or as a groove. In this case, the recess 14 may run partially or completely along the internal contour 12 of the collection manifold 6, i.e. the recess 14 may continue around the entire internal contour 12 of the collection manifold 6, with the recess 14 being designed as an opening only in the region of the feed to the flat tube 2. In the region where the flat tube 2 is fixed to the collection manifold 6, the recess 14 is designed as a bead or groove.

[0032] To be mounted in the heat exchanger 1, the end 8 of the respective flat tube 2 is fitted through the recess 14 and held in a positively locking manner in the collection manifold 6. To achieve a particularly secure non-positive lock for the holding of the flat tube 2 in the collection manifold 6, the end 8 of the respective flat tube 2 is held cohesively at the collection manifold 6. For this purpose, the end 8 of the respective flat tube 2 is preferably soldered along the recess 14 of the collection manifold 6. Alternatively, the end 8 may be adhesively bonded or welded. As illustrated in FIG. 2, the collection manifold 6 is here divided into two regions 16 which run transversely with respect to the air flow direction L. A collection manifold 6 which has been divided in two in this way, also referred to as a two-part collection box, allows differentiated and separate feeding of the individual flat tubes 2. To achieve a particularly pressure-resistant and stable arrangement of the heat exchanger 1, a fin 18 is arranged between the flat tubes 2 spaced apart from one another.

[0033] FIGS. 3A to 3C show an alternative embodiment of the heat exchanger 1. In this case, the end 8 of the respective flat tube 2 is provided with webs 20 on the outer side, which are sufficient to achieve a good strength and

rigidity in the case of a heat exchanger 1 designed for a low pressure. Depending on the design of webs 20, the opening 13, which represents them, of the end 8 of the associated flat tube 2 may likewise be produced by stamping or perforating. In this case, the flat tube 2 is connected to the collection manifold 6 in a positively locking manner in the region of the webs 20. FIG. 4 shows a perspective illustration of the heat exchanger 1 in accordance with FIGS. 3A to 3C, with this heat exchanger 1 having only a simple collection manifold 6.

[0034] FIGS. 5A to 5B and 6A to 6B show various cross-sectional shapes of the collection manifold 6 and as a result for the opening 13 provided in the end 8 of the respective flat tube 2. In FIGS. 5A to 5B, the collection manifold 6 has, for example, a round cross-sectional shape. In FIGS. 6A and 6B the collection manifold 6 is designed to be of rectangular or square cross section.

[0035] FIGS. 7A and 7B show an alternative embodiment of the heat exchanger 1. In this case, the end 8 of the respective flat tube 2, in particular its external contour 10, is at least partially matched to an external contour 22 which represents the collection manifold 6. The flat tube 2 is introduced into the collection manifold 6 via a cutout 24, which can be supplied from the outside, of the collection manifold 6 and/or via the recess 14, which opens out in the direction of the flat tubes 2, of the collection manifold 6, with the end 8 of the flat tube 2 projecting above the surface of the collection manifold 6 during assembly in the heat exchanger 1. That end 8 of the flat tube 2 which projects above the collection manifold 6 is then pressed together with and/or soldered to the external contour 22 of the collection manifold 6.

[0036] FIGS. 8A and 8B show an alternative embodiment of the heat exchanger 1. In this case, the collection manifold 6 is of one-part design. The end 8 of the respective flat tube 2 is provided with a split opening 13 for differentiated flow to the fluid passages 4. This split opening 13 is realized in a production step, for example by stamping holes into the end 8 of the respective flat tube 2. A profile- or frame-like design of the end 8 of the respective flat tube 2 of this type causes the flat tube to additionally reinforce the collection manifold 6 when it is arranged in a positively locking manner in the collection manifold 6. Furthermore, the openings 13 themselves form a flow passage 36 running through the collection manifold 6. In this case, flow can pass through the two openings 13 in the same way, in the same direction. Alternatively, one of the openings 13 can be used to supply the fluid F and the other opening 13 can be used to discharge the fluid F.

[0037] FIG. 9 shows one possible embodiment of a heat exchanger 1, having a collection manifold 6 which is of rectangular design and in which a plurality of flat tubes 2 having identical ends 8 are held in a positively locking manner and/or cohesively. For flow to pass through the passages 4 of adjacent flat tubes 2 in countercurrent, the collection manifold 6 is longitudinally and transversely divided into regions 16a to 16d by means of a partition wall 26. The collection manifold 6, by virtue of being divided into the regions 16a to 16d, is configured as a four-part collection manifold 6, so that a resulting heat exchanger 1 has only one collection manifold 6, arranged at one end 8 of the flat tubes 2, for supplying and discharging the fluid F.

[0038] The collection manifold 6 comprises an inlet passage 28 and an outlet passage 30 for respectively supplying and discharging the fluid F into and from regions 16a to 16d, which are separated from one another by the partition wall 26 and in which the openings 13, arranged therein, of the respective flat tubes 2 serve as flow passage 36. On account of the introduction of the partition wall 26 and the resulting division into regions 16a, 16c and 16b, 16d running in the longitudinal direction, the passages 4 arranged within an individual flat tube 2 likewise have the fluid F flowing through them in countercurrent. The division of the collection manifold 6, running in the transverse direction, into regions 16a, 16b and 16c, 16d means that flow passes through adjacent flat tubes 2 in the countercurrent principle. For flow to pass through the passages 4 of an individual flat tube 2 in the same direction, the partition wall 26 comprises at least one through-opening 32.

[0039] To receive the partition wall 26 in the collection manifold 6, the respective flat tube 2 is provided with a slot 34. The slot 34 is used both to guide the partition wall 26 and to secure the latter, for example by soldering or adhesive bonding. Flow to the flat tubes 2 may be configured differently, for example in cross-countercurrent in cross-cocurrent, in countercurrent and/or in cocurrent, depending on the type and design of the heat exchanger 1, in particular the configuration of the partition wall 26 with and/or without through-openings 32 or divisions.

[0040] FIG. 10 shows a further alternative embodiment of a heat exchanger 1, in which flow passes through the flat tubes 2 in different directions. In this case, it is possible to dispense with the partition wall 26 shown in FIG. 9 by virtue of the flat tubes 2 themselves serving as partitions on account of the design of their associated ends 8 differing in an appropriate way. For this purpose, a plurality of flat tubes 2a are provided with openings 13 at their end side for the fluid F to flow through. By contrast, a flat tube 2b which serves as a partition has a closed end 8. Furthermore, the ends 8 of the flat tubes 2 in each case open out into a collection manifold 6a and 6b, with the lower collection manifold 6b serving only to divert the fluid F in flat tubes 2a and 2b through which the fluid F flows in countercurrent. The upper collection manifold 6a serves both to supply and discharge the fluid F via a single flow passage 36, which is designed as an inlet passage 28 and outlet passage 30 and is formed by the openings 13 of the respective flat tubes 2, the fluid F flowing through the heat exchanger 1 in a U-shape, as seen in the longitudinal direction.

1. A heat exchanger (1) having a number of flat tubes (2) which are arranged parallel to and at a distance from one another and via at least one end (8) can be fed with a fluid (F) via a collection manifold (6), the flat tubes (2) being arranged at least partially in a positively locking manner in the collection manifold (6).

2. The heat exchanger as claimed in claim 1, in which an outer contour (10), which represents the end (8) of the respective flat tube (2), is at least partially matched to an internal contour (12) which represents the collection manifold (6).

3. The heat exchanger as claimed in claim 1, in which an outer contour (10), which represents the end (8) of the respective flat tube (2), is at least partially matched to an external contour (10) which represents the collection manifold (6).

4. The heat exchanger as claimed in claim 1, in which the end (8) of at least one of the flat tubes (2) is provided with one or more openings (13).

5. The heat exchanger as claimed in claim 1, in which the end (8) of at least one of the flat tubes (2) has an open contour or opening.

6. The heat exchanger as claimed in claim 1, in which the end (8) of at least one of the flat tubes (2) is provided with webs (20) on the outer side.

7. The heat exchanger as claimed in claim 1, in which the end (8) of at least one of the flat tubes (2) is provided with a further, centrally arranged web (20).

8. The heat exchanger as claimed in claim 2, in which the end (8) of the respective flat tube (2) is at least partially routed in a recess (14) which runs inside the internal contour (12).

9. The heat exchanger as claimed in claim 1, in which the end (8) of the respective flat tube (2) is held in a positively locking manner at the collection manifold (6).

10. The heat exchanger as claimed in claim 8, in which the end (8) of the respective flat tube (2) is soldered along the recess (14) of the collection manifold (6).

11. The heat exchanger as claimed in claim 1, in which the collection manifold (6) is provided with at least one cutout (24) or a recess (14) for one of the flat tubes (2) to pass through.

12. The heat exchanger as claimed in claim 11, in which the end (8) of the flat tube (2) in question is held cohesively at the cutout (24) of the collection manifold (6).

13. The heat exchanger as claimed in claim 1, in which the collection manifold (6) is longitudinally and/or transversely divided into at least two regions (16).

14. The heat exchanger as claimed in claim 1, in which the end (8) of at least one of the flat tubes (2) is provided with a slot (34) for receiving a partition wall (26).

15. The heat exchanger as claimed in claim 14, in which the partition wall (26) has a through-opening (32).

16. The heat exchanger as claimed in claim 1, in which the flat tubes (2) open out into an associated collection manifold (6) at each of the end sides.

17. The heat exchanger as claimed in claim 16, in which the collection manifolds (6) arranged at the end sides of the flat tubes (2) are of identical design.

18. The heat exchanger as claimed in claim 1, in which the flat tubes (2) arranged in a positively locking manner in the collection manifold (6) have differently designed ends (8).

19. The heat exchanger as claimed in claim 1, in which at least one of the flat tubes (2) arranged in a positively locking manner in the collection manifold (6) is closed and acts as a partition wall.

20. An air-conditioning system for a vehicle having a heat exchanger (1) as claimed in claim 1.

* * * * *