

G. REECE.
MACHINE FOR FOLDING COLLAR BLANKS, &c.

(Application filed May 15, 1901.)

(No Model.)

Fig. 1.

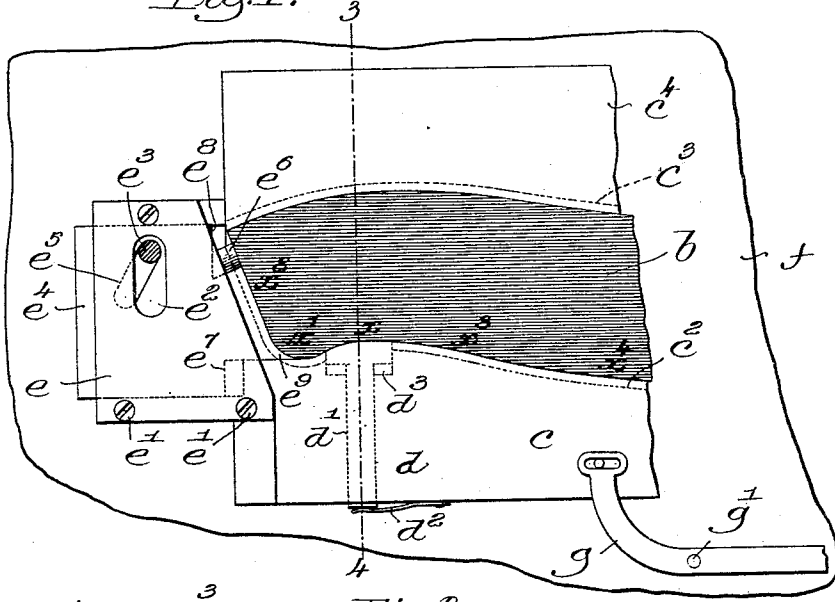

Fig. 2.



Fig. 3.

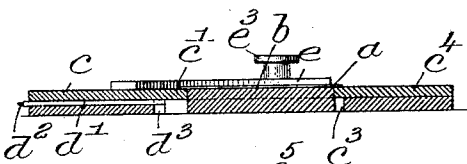

Fig. 4.

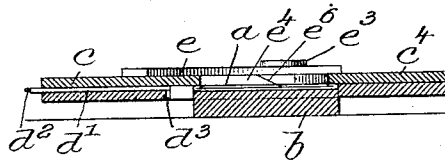
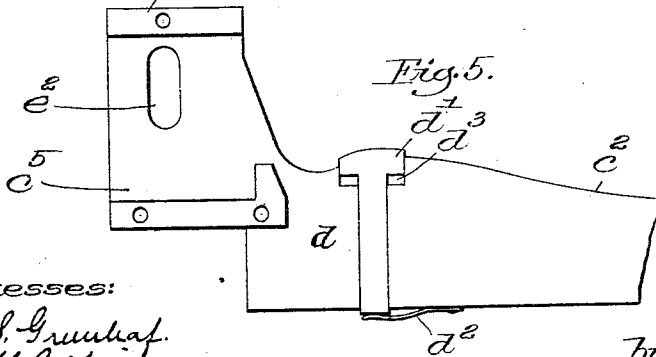

Fig. 5.



Witnesses:
Fred S. Grunhuf.
Adolph S. Haish

Inventor
George Reece.
By Stanley Gregory.

UNITED STATES PATENT OFFICE.

GEORGE REECE, OF WOLLASTON, MASSACHUSETTS, ASSIGNOR TO REECE FOLDING MACHINE COMPANY, OF BOSTON, MASSACHUSETTS.

MACHINE FOR FOLDING COLLAR-BLANKS, &c.

SPECIFICATION forming part of Letters Patent No. 680,174, dated August 6, 1901.

Application filed May 13, 1901. Serial No. 59,896. (No model.)

To all whom it may concern:

Be it known that I, GEORGE REECE, a citizen of the United States, residing at Wollaston, county of Norfolk, State of Massachusetts, have invented an Improvement in Devices for Folding Collars and the Like, of which the following description, in connection with the accompanying drawings, is a specification, like letters on the drawings representing like parts.

My present invention is an improvement in collar and cuff folding machines, and relates more particularly to details of the infolding mechanism. In making certain kinds of folds extreme difficulty is experienced because of the peculiar nature of the linen or other material constituting the blanks from which the article is made. For instance, where an inwardly-extending curve is to be folded along the edge of a collar if the folding-blade simply lifts up the edge of the material for the purpose of laying it over on the former or defining-die, the moment that the blade gets above the edge of the die the material of the blank is liable to straighten out, so that either an imperfect inward curve is formed or in some instances no curve whatever is formed.

Accordingly my present invention relates particularly to means for insuring an invariably accurate and neat fold of the kind referred to and also relates to the making of such a fold, particularly at a corner.

In carrying out my invention I provide means auxiliary to the main folder for retaining the material and preventing any possible slipping or displacement thereof when it has once been moved by the folding-blade into proper position for further infolding.

The constructional details of my mechanism and further advantages thereof and the operation of the parts will be more particularly set forth in the following description, reference being had to the accompanying drawings, in which I have shown one preferred embodiment of my invention, and the latter will be more definitely set forth in the claims.

In the drawings, Figure 1 is a fragmentary plan view of a portion of a machine sufficient to enable my invention to be understood.

Fig. 2 is a front edge elevation thereof. Figs. 3 and 4 are sectional details on the line 3 4, Fig. 1, the former figure showing the position of the parts before the folding operation has taken place, and Fig. 4 showing the parts after the folding has been accomplished. Fig. 5 is a top plan view of the lower plate or portion of the front folding-blade.

It will be understood that my invention is applicable to any kind of folding-machine where it may be desirable, and accordingly I have omitted the details of the machine proper and have confined myself to the improvements which constitute my invention.

A blank (indicated at *a*, Figs. 3 and 4, and by dotted lines in Fig. 1) is placed upon a bed or receiving-pad *b* of any usual kind, said pad conforming in shape to the article which is to be folded and receiving in the usual manner a former or die, (not shown,) which also conforms accurately, as is well understood, to the shape of the article to be folded.

For convenience of illustration I have herein indicated one of the current shapes for ladies' collars, having adjacent its corner an inward curve *x*, said corner being rounded, as indicated at *x'*, and having an obliquely-extending end *x²*, and the said curve *x* being sharper or more abrupt adjacent the corner and quite gradual at its opposite portion *x³*. If now the folds were made by a folding-blade *c* having simply a projecting folding edge *c'* and a defining or creasing shoulder *c²*, (such as indicated in section at *c³*, Fig. 3, in connection with the rear folding-blade *c⁴*,) it is evident that when the blade *c* should be raised from the position shown in Fig. 3 for turning up the overhanging edge of the blank *a* preparatory to infolding it the material would slip back beneath the edge *c'* into as nearly as possible a straight line between the points *x'* and *x⁴* the moment that the said edge *c'* was raised high enough to permit the cloth to slip back and straighten out, and then when the folding-blade was moved inwardly to make the fold the shoulder *c²* would simply crowd or pucker the material back into place ready to spring out again and would make an awkward and illy-defined crease or series of creases. This difficulty has been experienced more or less wherever reëntrant

angles or curves have been made, and I overcome said difficulty by providing a yielding ledge or shoulder, which follows up beneath the material as the overhanging edge of the latter is bent upwardly and automatically holds said material in place as the infolding is accomplished, said yielding shoulder or ledge being preferably carried by the folder itself and in any event cooperating therewith. As herein shown, I have cut away the under side of the folding-blade, so as to form a proper pocket for the auxiliary device, which is shown in the form of a plunger d , having an elongated defining end or edge shaper d' , shaped at its front edge to coincide with the contiguous edge of the pad b , this auxiliary edge-shaper being normally held inwardly by any suitable means, as by a spring d^2 . The recess or pocket for the auxiliary edge-shaper is large enough at its forward edge, as indicated at d^3 , to permit the folding-blade c to move fully forward, so that its shoulder d^3 is brought into alinement with the front edge of the defining end d' , this movement usually taking place just before the creasing pressure is to be brought upon the blank. The defining end of the edge-shaper may be short, as indicated, or longer, according to the kind of curve or angle which it is required to take care of in connection with the folding operation of the folding-blade proper. The difficulty of making such a fold is rendered still greater and more complex at the corner of the blank, and especially so when said corner is rounded, as shown in Fig. 1, and accordingly I provide a special end attachment for cooperating with the parts already explained in laying over the rounded corner and adjacent end without any possibility of slipping or leaving a gap or break in the folding edge as the parts move forward, said device being shown as comprising a top plate e , secured in any suitable manner, as by screws e' , to the blade c , the latter having a projection e^5 for this purpose. Said plate e has a slot e^2 to receive a set-screw or projection e^3 , which passes into the bed f of the machine, and sliding in or beneath said plate e is an end-folder e^4 , having an oblique slot e^5 , so that as the blade c is moved forward by any means, as by a lever g , pivoted at g' , the blade e^4 is moved laterally, the resulting movement being an oblique movement in the general direction of the end fold. The folding edge of the plate e^4 has a beveled end e^6 , which remains in place as the rear blade c^4 comes forward, thereby insuring a sharp and properly-made rear corner fold, although this last-mentioned feature is not herein claimed. The blade e^4 has its opposite front edges cut away, as indicated by dotted lines at e^7 e^8 , to permit it to move forward, as required and just explained. The result is that as the front blade c moves forward the edge-shaper d' holds the cloth tightly into the curve at x , and at the same time the curved front end e^9 of the blade e^4 draws over and inturns the

material around the curved corner, so that no slipping or unevenness can possibly take place, notwithstanding the reverse curves which the cloth is required to make around the portions $x x'$. The great importance of mechanism for accomplishing this difficult folding will be appreciated by those skilled in the art.

I do not intend to restrict the mechanism in which my invention may be embodied to the details herein shown, as I am aware that very many changes in form, arrangement, and relation of parts may be resorted to within the spirit and scope of my invention.

Having described my invention, what I claim as new, and desire to secure by Letters Patent, is—

1. A device for folding collars and the like, comprising a folding-blade for folding over and inturning an edge of a blank, and an auxiliary edge-shaper held yieldingly in proper position and including means for maintaining the edge of the blank against accidental outward movement while the folder is completing the folding operation.

2. A device for folding collars and the like, comprising a bed having a raised portion or pad for receiving a blank in position with the edges of the blank projecting over the edge of the pad, a folder having a folding edge for turning up and inwardly said projecting edge of the blank, a shoulder back of the edge of the folder and beneath the same, said shoulder corresponding in shape to the required shape of the blank when folded, an auxiliary edge-shaper for cooperating with said shoulder and normally projecting beyond said shoulder, and means maintaining said auxiliary edge-shaper in constant retaining position against the blank for preventing the edge of the latter from accidental displacement.

3. A device for folding collars and the like, comprising a folding-blade for folding over and inturning an edge of a blank, and an auxiliary edge-shaper carried by said blade on the under side thereof, and a spring normally projecting said edge-shaper in position to rest against the edge of the blank as the latter is being folded by said folder.

4. The herein-described mechanism for folding at the corner a blank having an inwardly-extending curve adjacent said corner, said mechanism consisting of a folder having an independently-movable auxiliary edge-shaper on its under side, means for moving said edge-shaper forward in position for defining said inwardly-extending curve, an end-folder provided with a folding edge contacting with the folding edge of said first-mentioned folder, and means for moving said end-folder laterally as the first-mentioned folder moves forward.

5. A folding mechanism, comprising a front edge-folder having at its end a guide-plate, an end-folder sliding in said guide-plate, the folding edges of said two folders being in alinement with each other and forming a con-

tinuous edge, said end-folder having an oblique slot, and said guide-plate having a slot in the direction of its forward movement, and a stationary pin passing through said two slots, the forward movement of said first-mentioned folder causing the end-folder to move simultaneously in a transverse direction.

6. The herein-described mechanism for folding a blank with a reverse curve comprising means for holding down the blank and defining the shape to be folded, the independently-movable folding members having together a folding edge corresponding in shape to the fold to be made, means for moving said two members respectively in the general

direction transversely of the portions of the reverse curve which they are respectively to fold, and means movable independently of said members for pressing against the blank at the convex portion of the curve and holding said blank in accurate position at said point during the completion of the folding operation.

In testimony whereof I have signed my name to this specification in the presence of two subscribing witnesses.

GEORGE REECE.

Witnesses:

GEO. W. GREGORY,
AUGUSTA E. DEAN.