



(51) International Patent Classification:

F21V 23/04 (2006.01) H01R 33/94 (2006.01)
F21V 23/06 (2006.01) H01R 33/96 (2006.01)
F21V 25/04 (2006.01) F21Y 103/00 (2006.01)
F21K 99/00 (2010.01)

(21) International Application Number:

PCT/IB2012/051367

(22) International Filing Date:

22 March 2012 (22.03.2012)

(25) Filing Language:

English

(26) Publication Language:

English

(30) Priority Data:

11160377.5 30 March 2011 (30.03.2011) EP

(71) Applicant (for all designated States except US):
KONINKLIJKE PHILIPS ELECTRONICS N.V.
[NL/NL]; Groenewoudseweg 1, NL-5621 BA Eindhoven (NL).

(72) Inventors; and

(75) Inventors/Applicants (for US only): **GIELEN, Vincent Stefan David** [NL/NL]; c/o High Tech Campus Building 44, NL-5656 AE Eindhoven (NL). **BUKKEMS, Peter Johannes Martinus** [NL/NL]; c/o High Tech Campus Building 44, NL-5656 AE Eindhoven (NL).

(74) Agents: **VAN EEUWIJK, Alexander Henricus Walterus** et al.; High Tech Campus Building 44, NL-5556 AE Eindhoven (NL).

(81) Designated States (unless otherwise indicated, for every kind of national protection available): AE, AG, AL, AM, AO, AT, AU, AZ, BA, BB, BG, BH, BR, BW, BY, BZ, CA, CH, CL, CN, CO, CR, CU, CZ, DE, DK, DM, DO, DZ, EC, EE, EG, ES, FI, GB, GD, GE, GH, GM, GT, HN, HR, HU, ID, IL, IN, IS, JP, KE, KG, KM, KN, KP, KR, KZ, LA, LC, LK, LR, LS, LT, LU, LY, MA, MD, ME, MG, MK, MN, MW, MX, MY, MZ, NA, NG, NI, NO, NZ, OM, PE, PG, PH, PL, PT, QA, RO, RS, RU, RW, SC, SD, SE, SG, SK, SL, SM, ST, SV, SY, TH, TJ, TM, TN, TR, TT, TZ, UA, UG, US, UZ, VC, VN, ZA, ZM, ZW.

[Continued on next page]

(54) Title: END CAP FOR A TUBULAR LIGHT SOURCE

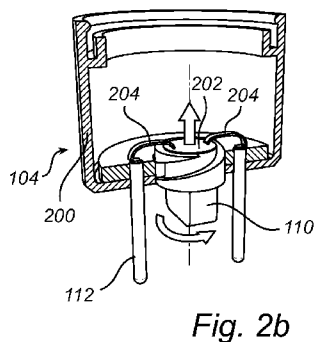
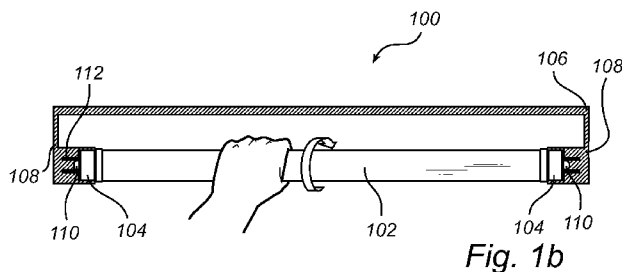

(57) Abstract: An end cap (104) for a tubular light source (102), the tubular light source (102) being configured to be arranged in a lighting fixture (106) comprising at least one socket (108), wherein the end cap (104) comprises a housing (202), two connector pins (112) at least partly arranged on an outside of the housing (202) and adapted to fit in the socket, and a switch assembly comprising a switch element (110) arranged in between the two connector pins (112) and at least partly protruding from an opening in the housing (202), wherein a first side of the switch element (110) is adapted to fit into a slot in a socket (108) and wherein the switch assembly is configured to form a conductive path between the socket (108) and the tubular light source (102) through an axial rotation of the switch element (110) in relation to the housing (202) as the tubular light source (102) is rotatably mounted in the fixture (106).

WO 2012/131547 A1

(84) Designated States (*unless otherwise indicated, for every kind of regional protection available*): ARIPO (BW, GH, GM, KE, LR, LS, MW, MZ, NA, RW, SD, SL, SZ, TZ, UG, ZM, ZW), Eurasian (AM, AZ, BY, KG, KZ, MD, RU, TJ, TM), European (AL, AT, BE, BG, CH, CY, CZ, DE, DK, EE, ES, FI, FR, GB, GR, HR, HU, IE, IS, IT, LT, LU, LV, MC, MK, MT, NL, NO, PL, PT, RO, RS, SE, SI, SK, SM, TR), OAPI (BF, BJ, CF, CG, CI, CM, GA, GN, GQ, GW, ML, MR, NE, SN, TD, TG).

Published:

- *with international search report (Art. 21(3))*
- *before the expiration of the time limit for amending the claims and to be republished in the event of receipt of amendments (Rule 48.2(h))*

End cap for a tubular light source

FIELD OF THE INVENTION

The present invention relates to an end cap for a tubular light source, and in particular to an end cap enabling safe installation of such a tubular light source.

5 BACKGROUND OF THE INVENTION

Fluorescent lighting tubes are commonly used in a large range of lighting systems as a result of advantages such as longer life time and better luminous efficiency compared to incandescent lamps. However, in the continuous effort to reduce power consumption, it is desirable to replace conventional light tubes with still more energy
10 efficient and environmental friendly alternatives. One such alternative is to use LED tubular light sources having a plurality of LED's arranged in a tube similar to the fluorescent tube. In order to facilitate a transition from fluorescent tube lights to LED tubular light sources, the LED tubular light sources should be configured to be mounted in already existing fixtures for fluorescent light tubes. However, the electrical circuitry is different in an LED tubular light
15 source compared to in a fluorescent light tube in that the LED tube may provide a current path between the two end caps. As a result, installation of retrofitted LED tubular light sources may be a safety hazard as it is possible to first install one end cap in the mains connected fixture while having the other end cap still exposed and carrying a live potential on the connection pins of the exposed cap. Thus, the installer may touch the exposed end cap
20 and get an electrical shock.

US2010/018178 discloses a suggestion on how the aforementioned safety issue may be alleviated by introducing a safety switch in the end cap of the LED tubular light source. However, a push-in safety switch according to US2010/018178 may in some cases be unintentionally engaged when the installer is pushing a first end of the tubular light source as
25 a second end is inserted into the fixture, thereby exposing the installer to potential hazard as the unconnected end cap may then have a live potential. Furthermore, the installer may gain a false sense of security as the presence of a safety switch may make the installer believe that installation is safe in all circumstances.

Therefore, there is a need for an improved safety mechanism to improve the safety for the installer when installing retrofitted LED tubular light sources.

SUMMARY OF THE INVENTION

5 In view of the aforementioned and other drawbacks of prior art, it is an object of the present invention to improve the safety when installing a tubular light source, in particular it is an object to provide an end cap for a tubular light source comprising LEDs, the end cap further comprising a safety switch to facilitate safe installation of the tubular light source in a fixture.

10 According to an aspect of the present invention, it is therefore provided an end cap for tubular light source, the tubular light source being configured to be arranged in a lighting fixture comprising at least one socket, wherein the end cap comprises a housing, two connector pins at least partly arranged on an outside of the housing and adapted to fit in the socket, and a switch assembly comprising a switch element arranged in between the two
15 connector pins and at least partly protruding from an opening in the housing, wherein a first side of the switch element is adapted to fit into a slot in a socket and wherein the switch assembly is configured to form a conductive path between the socket and the tubular light source through an axial rotation of the switch element in relation to the housing as the tubular light source is rotatably mounted in the fixture.

20 The present invention is based on the realization that a safety switch for a tubular light source may advantageously be integrated into the end cap of the tube and that the safety switch preferably is automatically closing an electrical circuit by forming a conductive path between the socket and the tubular light source during installation of such a light source. In particular, in some tubular light sources, the internal circuitry is arranged so
25 that the light source may provide a conductive path from the connector pins in one end portion of an elongate tube to connector pins in the opposite end portion even if the light source is not active contrary to what was possible in conventional fluorescent light tubes. In other words, it is possible that mounting one end portion of the tubular light source in the socket of the lighting fixture leads to the connector pins in the opposite end portion carrying a
30 live voltage. In particular, having a push-in mechanism arranged on the end cap may cause the installer to unintentionally push the safety mechanism during installation of the tubular light source, thereby engaging the electrical circuit. By having a switch which automatically closes an electrical circuit only when the connector pins are out of reach for the installer, the

risk for the installer of receiving an electrical shock when installing a tubular light source is significantly reduced.

In one embodiment, the conductive path may advantageously be formed at a second side of the switch element, wherein the second side is arranged inside of the housing.

5 Arranging the switch mechanism inside of the housing provides additional safety as any conductive part is out of reach. The conductive path may for example be formed by aligning a conductive element with the two connector pins, wherein the conductive element is electrically connected to the tubular light source. Such a switch arrangement ensures that the connector pins are only electrically connected after the tubular light source has been installed
10 in the fixture.

According to one embodiment the switch element may be equipped with screw threads enabling axial movement of the switch element through a rotation of the switch element in relation to the housing. Furthermore, by using an axially movable switch element having screw threads, the conductive path may advantageously be formed through an axial
15 movement of the switch element. More particularly, the switch element is preferably arranged in the housing so that the rotation coincides with the rotational mounting of the tubular light source in a way that no extra steps are required to be performed by the person installing the light source. However, the configuration of the switch element is not limited to the aforementioned switch elements, the switch element may equally well be any rotary
20 switch element known to the person skilled in the art performing the above described function.

In one embodiment, the tubular light source may advantageously comprise a plurality of LEDs. LEDs are advantageously used as a replacement for fluorescent light sources as LED are more power efficient, smaller in size and have a longer life-length as well
25 as being more environmental friendly. Thereby, using LEDs may improve a tubular light source both with regard to environmental aspects and to the overall economy of the light source as power consumption is reduced and as fewer replacements are needed.

According to one embodiment, at least one end cap as discussed above may advantageously be arranged on at least one end of a tubular illuminator part comprising a
30 plurality of light emitting elements in order to form a tubular light source. Furthermore, such a tubular light source may advantageously be provided with an appropriate fixture comprising at least one socket for receiving the at least one end cap and for connecting the tubular light source to an electrical power supply, thereby forming a luminaire. Additionally, the tubular light source may advantageously comprise optics configured to mix light. Such

optics may be any mixing and/or collimating means. Light mixing optics may advantageously be used if the light emitting elements comprise LEDs. However, the light emitting elements may be any light source such as a fluorescent or incandescent light source.

5 BRIEF DESCRIPTION OF THE DRAWINGS

These and other aspects of the present invention will now be described in more detail with reference to the appended drawings showing currently preferred embodiments of the invention, wherein:

Fig. 1 illustrates a circuit arrangement;

10 Fig. 2 is schematically illustrating an end cap according to an exemplary embodiment of the present invention;

Fig. 3 is schematically illustrating an end cap according to another embodiment of the present invention; and

15 Fig. 4 is schematically illustrating an end cap according to another embodiment of the present invention.

DETAILED DESCRIPTION

The present invention will now be described more fully hereinafter with reference to the accompanying drawings, in which currently preferred embodiments of the 20 invention are shown. This invention may, however, be embodied in many different forms and should not be construed as limited to the embodiments set forth herein; rather, these embodiments are provided for thoroughness and completeness, and fully convey the scope of the invention to the skilled person. Like reference characters refer to like elements throughout.

25 In order for an electrically powered device to be powered a closed circuit through which electrical current can flow needs to be established. Typical examples of electrically powered devices include, but are not limited to, light sources, luminaires, LED retrofits of linear TL tubes, and the like. Electrically powered devices are provided with electrical connecting means by which the electrically powered devices can be electrically 30 connected to an interface (such as a device socket or a device holder) of a fixture which in turn is connected to an electrical power supply. Hence, when properly connected to the interface an electrical current may be provided to the electrically powered device. Commonly, the electrically powered device has two electrical connecting means (electrical contacts, such as pins) for connecting the electrically powered device to the electrical power

supply via the interface to result in a closed circuit. Some electrically powered devices have more than two electrical connecting means which enable multiple current paths.

Furthermore, for most common electrical connecting means where all pins of the electrical connecting means are at the same end, such as the normal mains plug of an electrically powered device, it is due to the length of the pins and the size of the socket not possible to connect only one pin whilst leaving the other pin exposed so that it may be accidentally touched. However, there are also some types of housings which have all electrical connecting means at one end. In some cases the mechanical design (geometry, shape, etc.) of the housing and/or interface, possibly together with the placing of the electrical connecting means on the housing, may prevent the electrical connecting means from being connected to the interface means in a wrong way, and thereby prevent unsecure installation. But in other cases this does not prevent the electrical connecting means from being connected to the interface means in an unsecure way.

The potential hazard described above may relate to retrofit LED tubular light sources as the power converter/ballast provides a current path through the tube. In contrast to this, a gas filled tube may not conduct any current unless ignited by the ignition voltage which commonly requires a connection at both ends of the tubular light source. Hence, due to the nature of the different types of electrically powered devices the installer might not be aware of the potential hazard originating from the uninstalled pins.

In the following, various embodiments of an end cap according to the present invention are mainly discussed with reference to an end cap for a tubular light source providing safety through a rotational motion.

Figs. 1a and 1b schematically illustrates a luminaire 100 wherein a tubular light source 102 comprising an end cap 104 according to the present invention is being mounted into a fixture 106. The fixture 106 is in turn connected to the power mains or any other power supply. The end cap 104 is adapted to be inserted into a socket 108 having a slot for receiving the connector pins 112 of the end cap 104. The end cap 104 is further equipped with a switch element 110 which closes the electrical circuit of the luminaire 100 upon rotation of the end cap 104 in relation to the socket when the end cap is mounted in the socket. The connector pins 112 and the switch element 110 of the end cap 104 are further configured to be inserted into a receiving slot in the socket 108 simultaneously. As illustrated in a first step Fig. 1a, the end caps 104 are inserted into the corresponding sockets 108 in the fixture 106 by sliding the connector pins 112 and the switch element 110 into the receiving slot in the socket 108. After that, the mounting is completed by rotating the tubular light

source 102 as illustrated in Fig. 1b. As the tubular light source 102 is mechanically connected to the end cap, and the switch element 110 is rotationally connected to the end cap, the switch element 110 is simultaneously rotated in relation to the end cap 104. The rotation of the switch element 110 in relation to the end cap 104 forms a conductive path between the connector pins 112 and the tubular light source 102, thereby closing the electrical circuit of the luminaire 100.

Figs. 2 to 4 schematically illustrate various preferred embodiments of an end cap according to the present invention. A currently preferred embodiment will now be described with reference to Fig. 2 showing a sectional view of an end cap 104. The end cap comprises a housing 202 and a switch element 110 which is axially rotatable in relation to the housing 202. When the end cap 104 is mounted in a socket 108, both the connector pins 112 and the elongate protruding portion of the switch element 110 are inserted into a receiving slot in the socket 108. The switch element 110 in Fig. 2 is threaded and arranged with corresponding threads in the housing 202 so that when the switch element 110 is rotated through a rotation of the end cap 104 in the socket 108, the switch element 110 moves in an axial direction. The side of the switch element 110 facing the inside of the housing has a conductive surface 202 so that when the switch element 110 is moved in an axial direction, the conductive surface 202 makes contact with connecting means 204 attached to the connector pins 112 as illustrated in Fig. 2b. The conductive surface 202 of the switch element 110 is further connected to the tubular light source 102 so as to form a conductive path between the connector pins 112 and the tubular light source 102, thereby closing the electrical circuit of the luminaire 100, when the switch element 110 is rotated. The conductive portion 202 of the switch element 110 may also be connected to any intermediate control circuitry arranged between the end cap 104 and the tubular light source 102 required to operate the tubular light source 102.

Figs. 3a and 3b schematically illustrates an alternative embodiment of the end cap 104 wherein the switch element 110 is equipped with an embedded conductive element 300 traversing the switch element 110 thereby contacting the connecting means 302 upon rotation of the switch element 110 and forming a conductive path between the connector pins 112 and the tubular light source 102 analogously to previously described embodiments.

Figs. 4a and 4b schematically illustrates another alternative embodiment of the end cap 104 where the switch element 110 is equipped with a conductive element 400 traversing the switch element 110 thereby contacting the connector pins 112 upon rotation of

the switch element 110 and forming a conductive path analogously to previously described embodiments.

The disclosed end cap will work with any electrical circuitry inside the housing or the tubular light source and with any wiring and ballasting of the luminaire comprising the sockets 108 such as, but not limited to magnetic ballast, glow starter, 5 electronic starter, series connection of lamps, HF cold start, HF warm start, shorted pins per end and the like.

Even though the invention has been described with reference to specific exemplifying embodiments thereof, many different alterations, modifications and the like 10 will become apparent for those skilled in the art. For example, the switch element may be any rotary switch element known to the person skilled in the art. Also, it should be noted that parts of the disclosed end cap may be omitted, interchanged or arranged in various ways, the end cap yet being able to perform the functionality of the present invention.

Additionally, variations to the disclosed embodiments can be understood and 15 effected by the skilled person in practicing the claimed invention, from a study of the drawings, the disclosure, and the appended claims. In the claims, the word "comprising" does not exclude other elements or steps, and the indefinite article "a" or "an" does not exclude a plurality. The mere fact that certain measures are recited in mutually different dependent claims does not indicate that a combination of these measured cannot be used to advantage.

CLAIMS:

1. An end cap (104) for a tubular light source (102), the tubular light source (102) being configured to be arranged in a lighting fixture (106) comprising at least one socket (108), wherein the end cap (104) comprises:
 - a housing (202);
 - 5 two connector pins (112) at least partly arranged on an outside of the housing (202) and adapted to fit in the socket; and
 - a switch assembly comprising a switch element (110) arranged in between the two connector pins (112) and at least partly protruding from an opening in the housing (202), wherein a first side of the switch element (110) is adapted to fit into a slot in a socket (108)
 - 10 and wherein the switch assembly is configured to form a conductive path between the socket (108) and the tubular light source (102) through an axial rotation of the switch element (110) in relation to the housing (202) as the tubular light source (102) is rotatably mounted in the fixture (106).
- 15 2. The end cap (104) according to claim 1, wherein the conductive path is formed at a second side of the switch element (110), wherein the second side is arranged in an inside of the housing.
3. The end cap (104) according to any one of the preceding claims, wherein the
- 20 switch element (110) is equipped with screw threads enabling axial movement through a rotation of the switch element (110).
4. The end cap (104) according to any one of the preceding claims, wherein the
- 25 conductive path is formed through an axial movement of the switch element (110).
5. The end cap (104) according to any one of the preceding claims, wherein the tubular light source (102) comprises a plurality of light emitting elements.

6. A tubular light source (102) comprising:
an illuminator part comprising a plurality of light emitting elements; and
at least one end cap (104) part according to any one of claims 1 to 5 arranged
on at least one end of the illuminator part.

5

7. The tubular light source (102) according to claim 6, further comprising optics
configured to mix light emitted by the light emitting elements.

8. A luminaire (100) comprising:

10

a tubular light source (102) according to claim 6 or 7; and
a fixture (106) comprising at least one socket (108) for receiving the at least
one end cap (104) and for connecting the tubular light source (102) to an electrical power
supply.

1/3

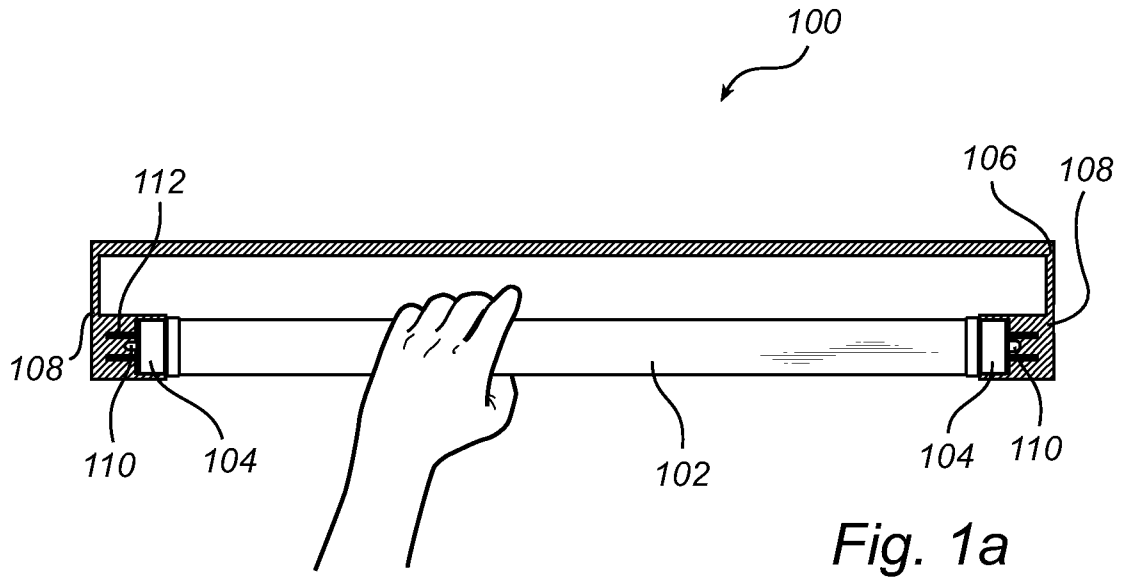

Fig. 1a

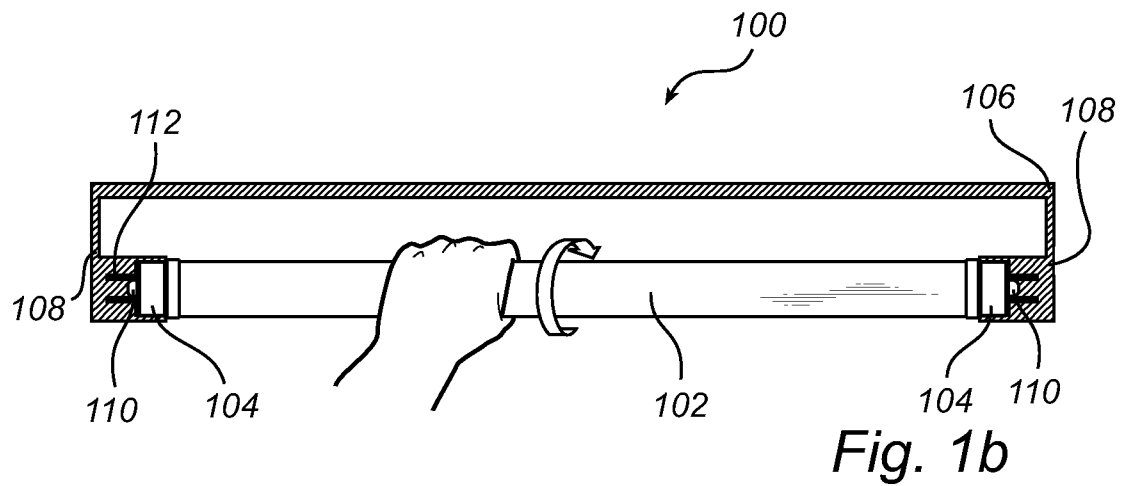
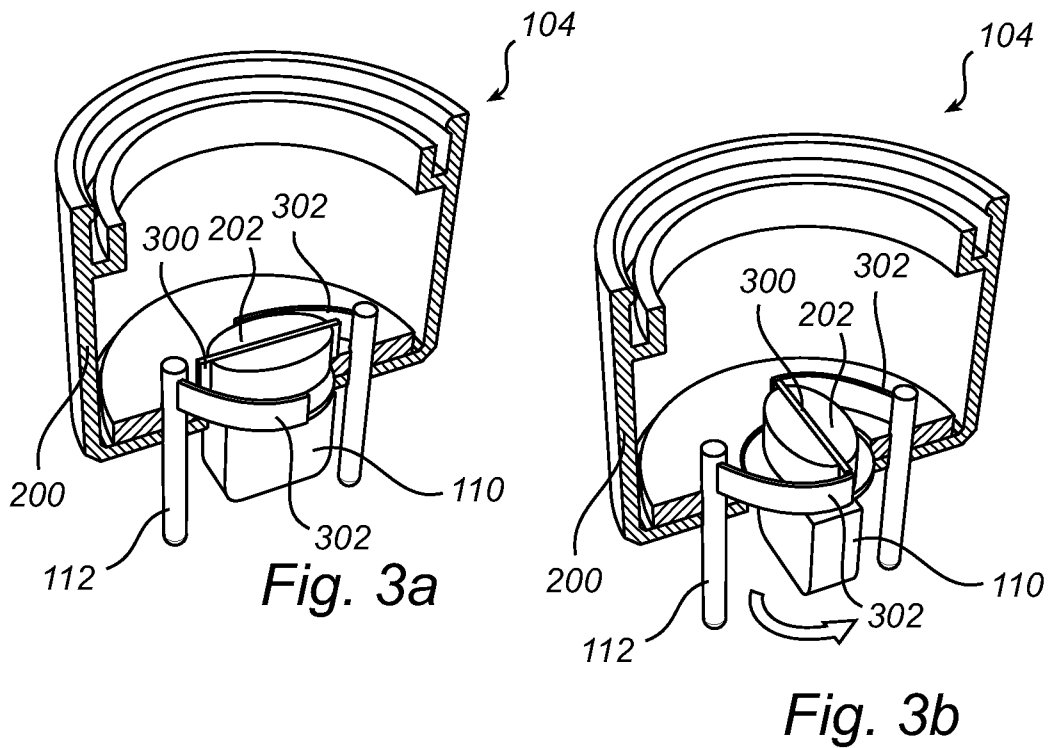
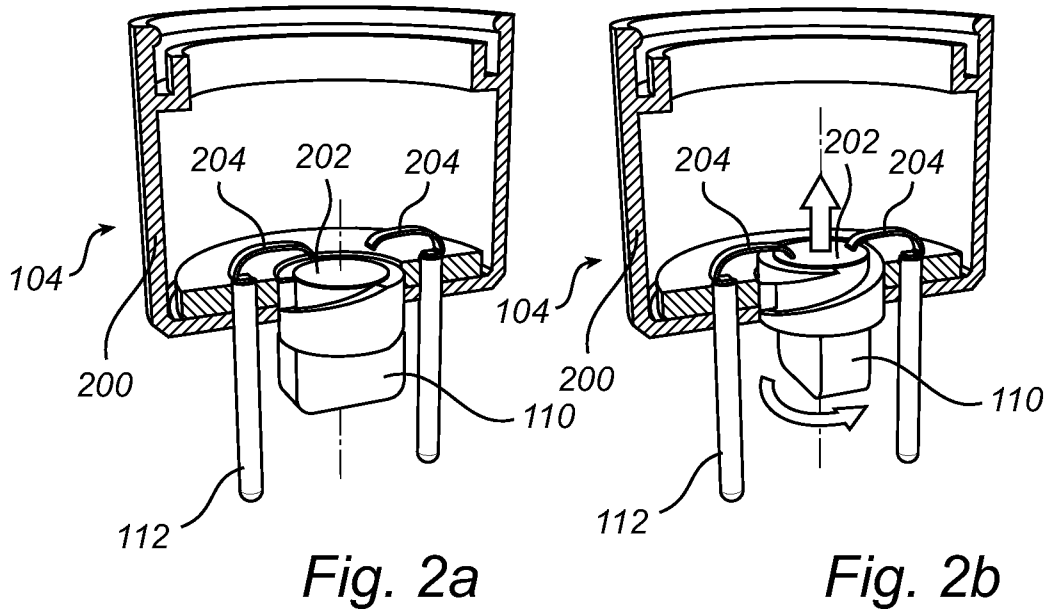
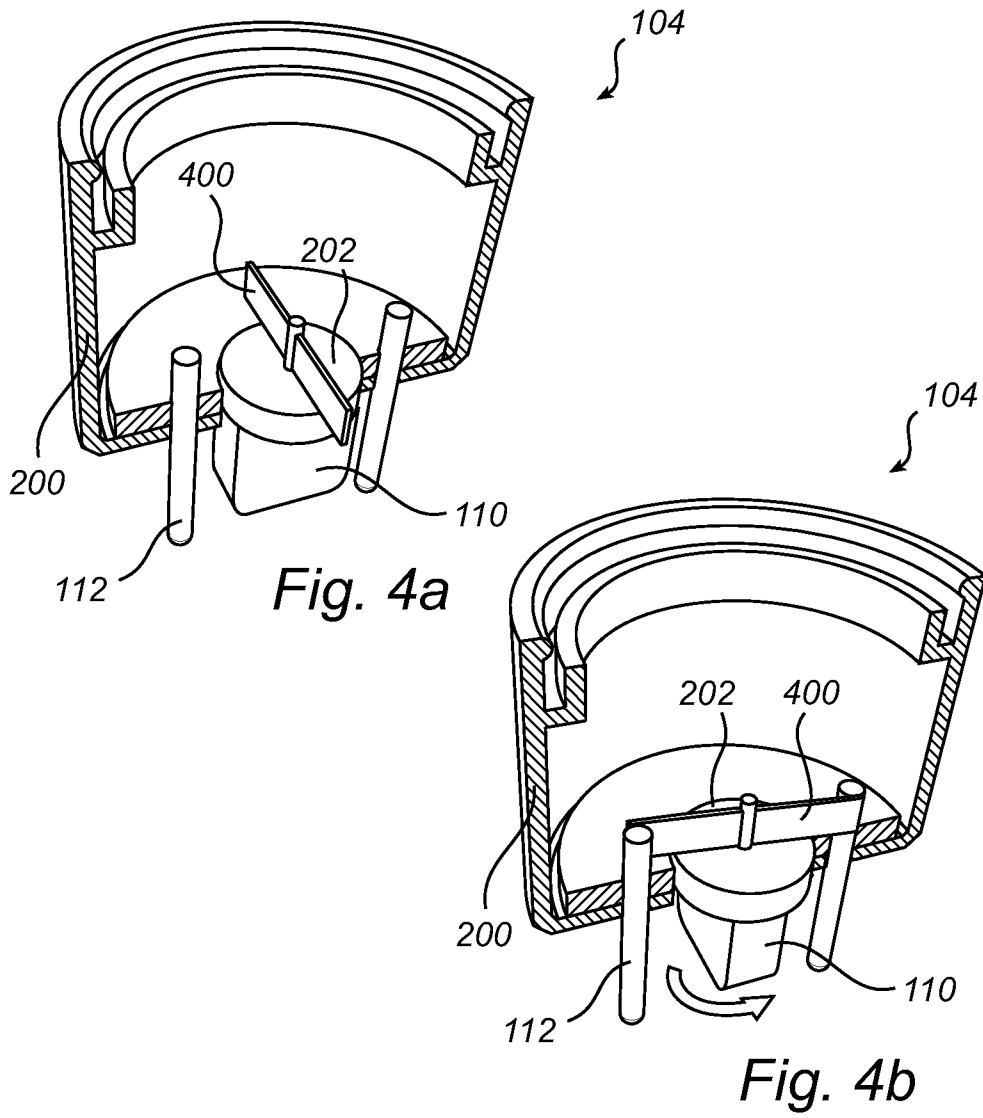

Fig. 1b

2/3



3/3



INTERNATIONAL SEARCH REPORT

International application No PCT/IB2012/051367

A. CLASSIFICATION OF SUBJECT MATTER INV. F21V23/04 F21V23/06 F21V25/04 F21K99/00 H01R33/94 H01R33/96 ADD. F21Y103/00 According to International Patent Classification (IPC) or to both national classification and IPC				
B. FIELDS SEARCHED Minimum documentation searched (classification system followed by classification symbols) F21V F21K H01R Documentation searched other than minimum documentation to the extent that such documents are included in the fields searched Electronic data base consulted during the international search (name of data base and, where practicable, search terms used) EPO-Internal				
C. DOCUMENTS CONSIDERED TO BE RELEVANT				
Category*	Citation of document, with indication, where appropriate, of the relevant passages	Relevant to claim No.		
A	JP 2010 192229 A (COOLIGHT JAPAN CO LTD) 2 September 2010 (2010-09-02) abstract; figures 1-3 -----	1-8		
A	WO 2009/067074 A1 (ESKILSTUNA ELEKTRONIKPARTNER A [SE]; ESKILSTUNA ELEKTRONIK AB [SE]; LA) 28 May 2009 (2009-05-28) the whole document -----	1-8		
A	US 2010/181178 A1 (CHANG JAMES TSENG HSU [HK] ET AL) 22 July 2010 (2010-07-22) the whole document -----	1-8		
A	WO 2010/069983 A1 (LEDNED HOLDING B V [NL]; VISSER JURJEN HILWERT [NL]; YU GUANG ZHI [CN]) 24 June 2010 (2010-06-24) abstract; figures 8a-8c -----	1-8		
<input type="checkbox"/> Further documents are listed in the continuation of Box C. <input checked="" type="checkbox"/> See patent family annex.				
* Special categories of cited documents : <table style="width: 100%; border: none;"> <tr> <td style="width: 50%; border: none; vertical-align: top;"> "A" document defining the general state of the art which is not considered to be of particular relevance "E" earlier application or patent but published on or after the international filing date "L" document which may throw doubts on priority claim(s) or which is cited to establish the publication date of another citation or other special reason (as specified) "O" document referring to an oral disclosure, use, exhibition or other means "P" document published prior to the international filing date but later than the priority date claimed </td> <td style="width: 50%; border: none; vertical-align: top;"> "T" later document published after the international filing date or priority date and not in conflict with the application but cited to understand the principle or theory underlying the invention "X" document of particular relevance; the claimed invention cannot be considered novel or cannot be considered to involve an inventive step when the document is taken alone "Y" document of particular relevance; the claimed invention cannot be considered to involve an inventive step when the document is combined with one or more other such documents, such combination being obvious to a person skilled in the art "&" document member of the same patent family </td> </tr> </table>			"A" document defining the general state of the art which is not considered to be of particular relevance "E" earlier application or patent but published on or after the international filing date "L" document which may throw doubts on priority claim(s) or which is cited to establish the publication date of another citation or other special reason (as specified) "O" document referring to an oral disclosure, use, exhibition or other means "P" document published prior to the international filing date but later than the priority date claimed	"T" later document published after the international filing date or priority date and not in conflict with the application but cited to understand the principle or theory underlying the invention "X" document of particular relevance; the claimed invention cannot be considered novel or cannot be considered to involve an inventive step when the document is taken alone "Y" document of particular relevance; the claimed invention cannot be considered to involve an inventive step when the document is combined with one or more other such documents, such combination being obvious to a person skilled in the art "&" document member of the same patent family
"A" document defining the general state of the art which is not considered to be of particular relevance "E" earlier application or patent but published on or after the international filing date "L" document which may throw doubts on priority claim(s) or which is cited to establish the publication date of another citation or other special reason (as specified) "O" document referring to an oral disclosure, use, exhibition or other means "P" document published prior to the international filing date but later than the priority date claimed	"T" later document published after the international filing date or priority date and not in conflict with the application but cited to understand the principle or theory underlying the invention "X" document of particular relevance; the claimed invention cannot be considered novel or cannot be considered to involve an inventive step when the document is taken alone "Y" document of particular relevance; the claimed invention cannot be considered to involve an inventive step when the document is combined with one or more other such documents, such combination being obvious to a person skilled in the art "&" document member of the same patent family			
Date of the actual completion of the international search	Date of mailing of the international search report			
4 September 2012	13/09/2012			
Name and mailing address of the ISA/ European Patent Office, P.B. 5818 Patentlaan 2 NL - 2280 HV Rijswijk Tel. (+31-70) 340-2040, Fax: (+31-70) 340-3016	Authorized officer Chaloupy, Marc			

INTERNATIONAL SEARCH REPORT

Information on patent family members

International application No PCT/IB2012/051367

Patent document cited in search report	A	Publication date	Patent family member(s)	Publication date
JP 2010192229	A	02-09-2010	NONE	
WO 2009067074	A1	28-05-2009	EP 2217855 A1	18-08-2010
			SE 0702576 A	20-05-2009
			WO 2009067074 A1	28-05-2009
US 2010181178	A1	22-07-2010	NONE	
WO 2010069983	A1	24-06-2010	CN 102318441 A	11-01-2012
			EP 2380403 A1	26-10-2011
			US 2012043892 A1	23-02-2012
			WO 2010069983 A1	24-06-2010