

[54] **COOKING APPARATUS FOR TOASTED SANDWICHES**

[75] **Inventor:** David Thelander, Lota, Australia

[73] **Assignee:** Multimould Enterprises Pty. Ltd., Wynnum Central, Australia

[**] **Term:** 14 Years

[21] **Appl. No.:** 942,179

[22] **Filed:** Sep. 14, 1978

[51] **Int. Cl.** D07-02

[52] **U.S. Cl.** D7/88; D7/96

[58] **Field of Search** D7/85, 87, 88, 89, 91, D7/92, 94, 96; 99/374, 375, 380

[56] **References Cited**

U.S. PATENT DOCUMENTS

D. 175,547	9/1955	Josephson	D7/88
D. 190,008	3/1961	Rioux	D7/92 X
D. 235,610	7/1975	Giguere et al.	D7/87 X
1,663,719	3/1928	Morley	D7/88 X
1,859,004	5/1932	Reich	D7/87 X
3,493,726	2/1970	Bardeau	D7/85 X
3,669,006	6/1972	Lee, Sr.	99/376 X
3,719,507	3/1973	Bardeau	99/375

OTHER PUBLICATIONS

Good Housekeeping, Jan., 1978, p. 116, Donut Makers, top center of page, item #C Exeter.

HFD-Retailing Home Furnishings, Nov. 27, 1978, p. 27, Dazey Donet Maker (4 wells).

Primary Examiner—Winifred E. Herrmann

Attorney, Agent, or Firm—Schwartz, Jeffery, Schwaab, Mack, Blumenthal & Koch

[57] **CLAIM**

The ornamental design for a cooking apparatus for toasted sandwiches, as shown and described.

DESCRIPTION

FIG. 1 is a top front perspective view of a cooking apparatus for toasted sandwiches showing the left side of my new design;

FIG. 2 is a front perspective view thereof, the upper platen being in an open condition;

FIG. 3 is a right side perspective view thereof on an enlarged scale;

FIG. 4 is a left side elevational view thereof on an enlarged scale;

FIG. 5 is a bottom plan view thereof on an enlarged scale; and

FIG. 6 is a rear elevational view thereof.

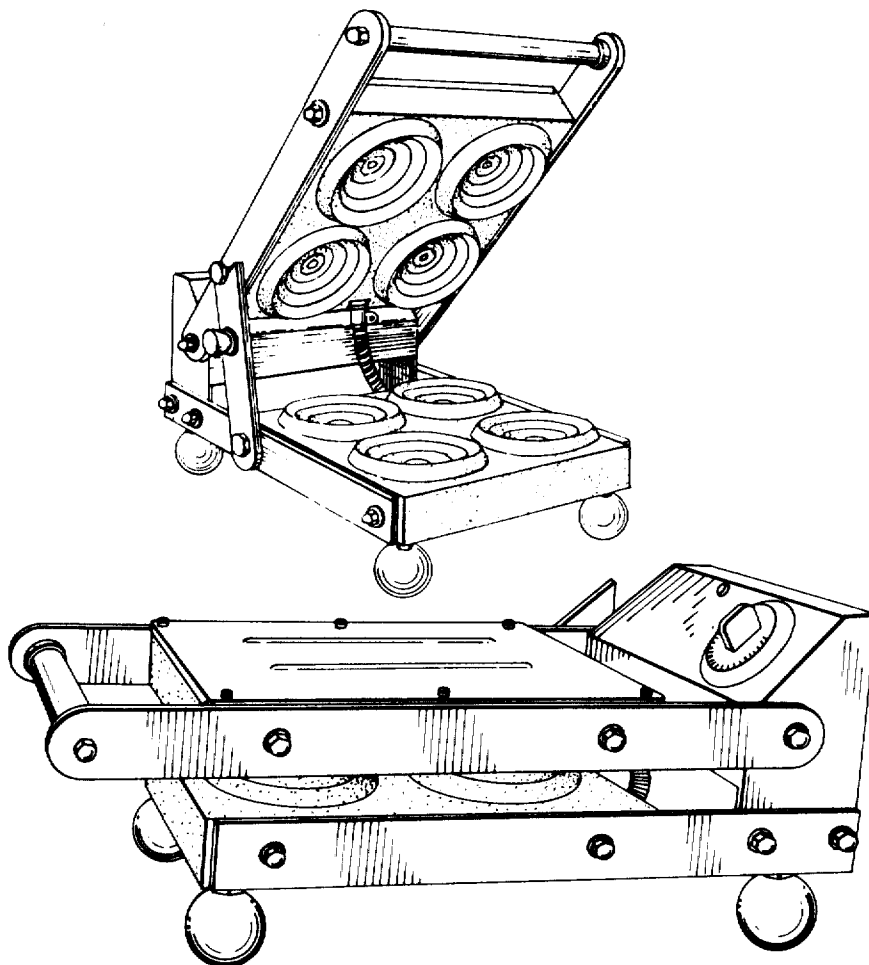

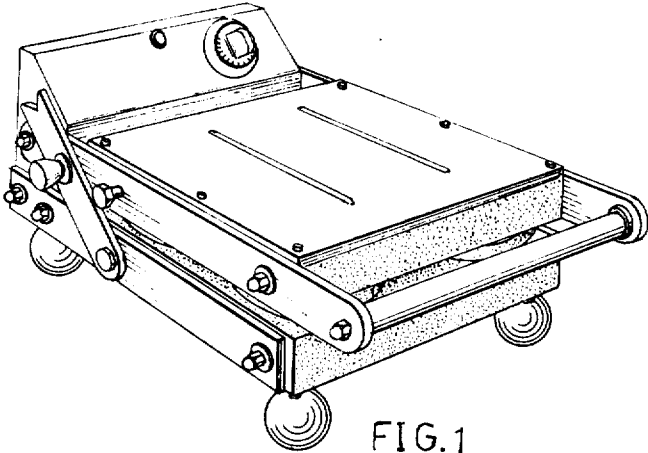

FIG. 1

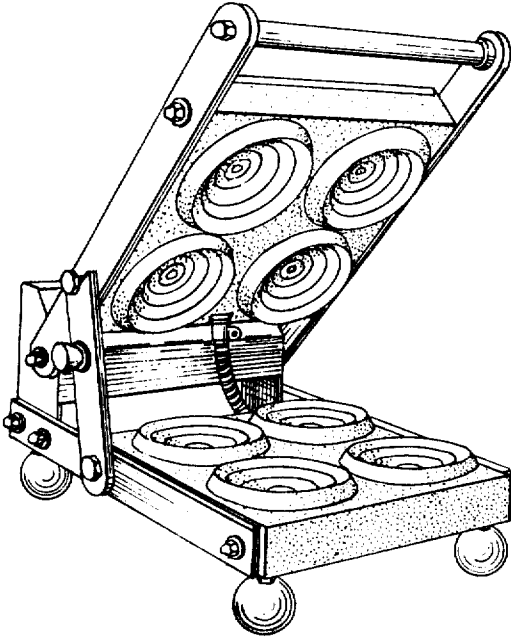

FIG. 2

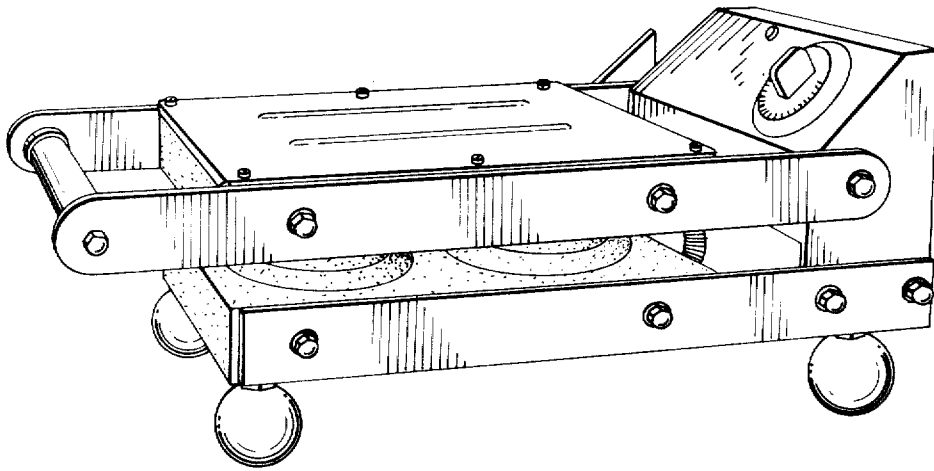

FIG. 3

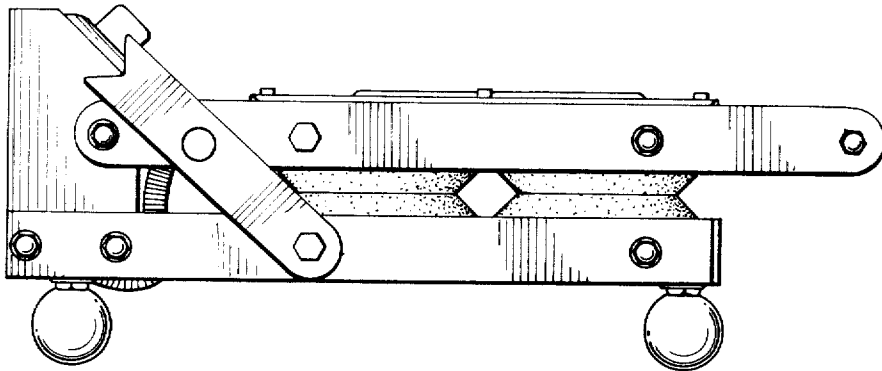

FIG. 4

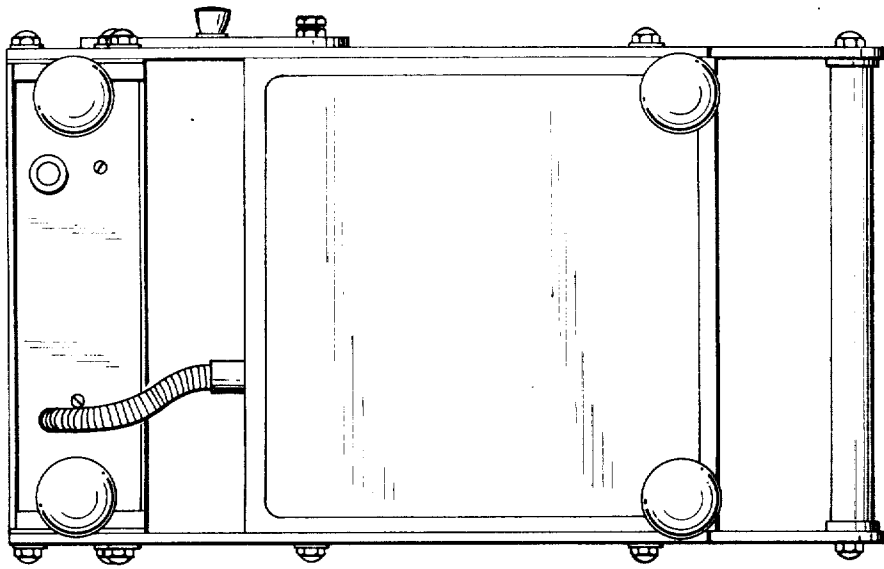

FIG.5

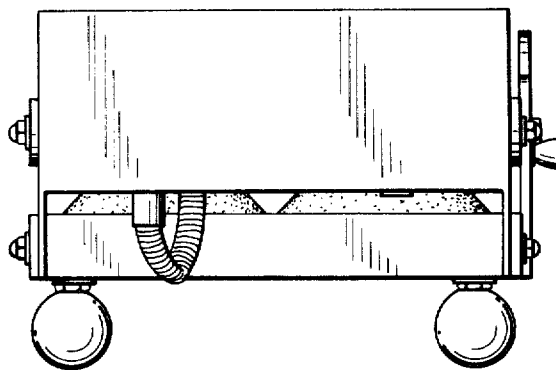

FIG.6