

W. LESSING.
REVOLVING ADJUSTABLE KILN.

(Application filed Apr. 23, 1900.)

(No Model.)

2 Sheets—Sheet 1.

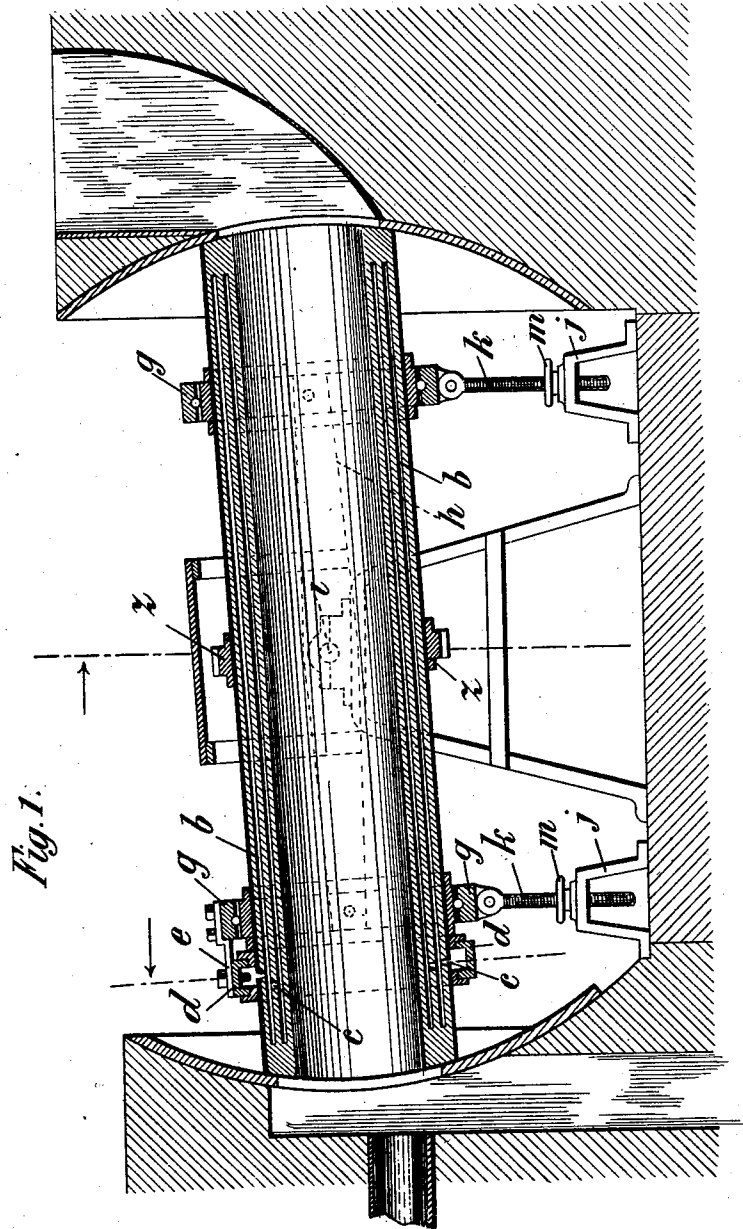

Fig. 1.

Witnessed.
Robert Aiton
E. H. Bond

Inventor,
Wilhelm Lessing
by Thos. A. Aiton
Atty.

W. LESSING.
REVOLVING ADJUSTABLE KILN.

(Application filed Apr. 23, 1900.)

(No Model.)

2 Sheets—Sheet 2.

Fig. 3

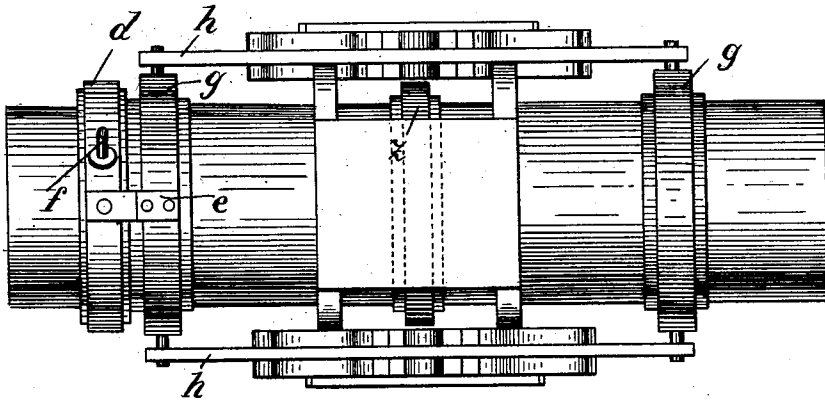
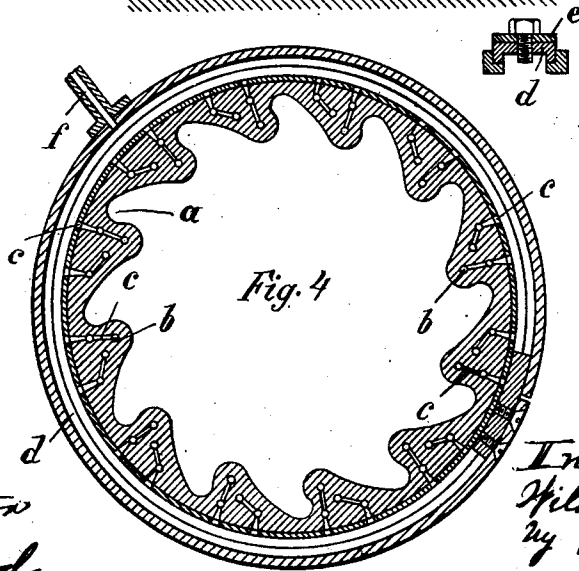
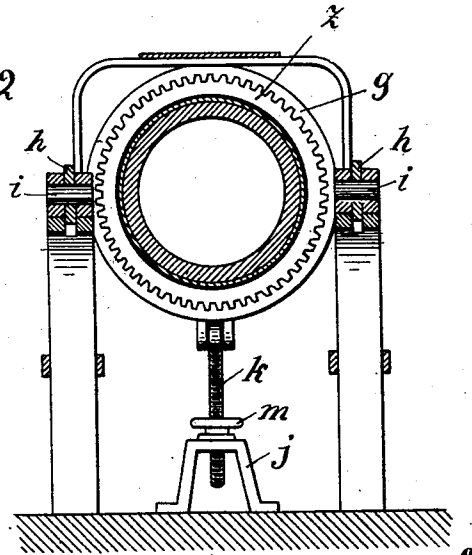

Fig. 2



Witnesses
 Robert Aiton
 E.A. Bond

Inventor
 Wilhelm Lessing
 by Thos. J. Aiton
 Atty.

UNITED STATES PATENT OFFICE.

WILHELM LESSING, OF GESECKE, GERMANY.

REVOLVING ADJUSTABLE KILN.

SPECIFICATION forming part of Letters Patent No. 678,411, dated July 16, 1901.

Application filed April 23, 1900. Serial No. 14,035. (No model.)

To all whom it may concern:

Be it known that I, WILHELM LESSING, a subject of the Emperor of Germany, residing at Gesecke, Westphalia, Germany, have invented a new and Improved Revolving Adjustable Kiln, of which the following is a specification.

In the construction heretofore known of revolving kilns for the continued burning of earths and chemicals said kilns or ovens were provided with an inner jacket of fireproof material. When the material to be burned passed through such kilns in lumps, each lump had a frictional effect upon the lining of the kilns, so that the said lining was in a short time completely worn away and had to be replaced in time in order to prevent the burning of the metal jacket of the kiln. If, on the other hand, in order to prevent the wearing away of the lining the material was introduced into the kiln in the form of powder instead of in lumps, the additional disadvantage resulted, owing to the known increased tendency of the pulverized material to cake and form an adhesive mass under the influence of high temperature, that the caked material adhered to the sides of the kiln and that the continual accumulation thereof and the revolving of the kiln resulted in the latter becoming gradually stopped up, so that ultimately no more material could pass through.

The object of the present invention is a revolving kiln for the continued burning of earths and chemicals in which the above-mentioned disadvantages are removed and the porous and fireproof linings for the kiln-channels are provided and so constructed that outer air for combustion can be forced through the pores of said lining into the kiln. Rapid burning of the lining and the accumulation of slag thereon are prevented, while the heat in the kiln, which hitherto penetrated the lining of the same, is forced back into the kiln through this constant flow of air which passes inwardly through the said lining. The air itself is also intensely heated in advance and carries oxygen of a very high temperature to the interior of the kiln, by which circumstance the burning process is considerably accelerated.

The kiln forming the object of the present invention is suspended in such a manner that

it can oscillate on a fixed frame and can be given any desired degree of inclination by means of adjusting-screws, so that the speed with which the material passes through the kiln can be regulated by altering the position of the latter.

In the annexed drawings a form of construction of the kiln is represented.

Figure 1 is a longitudinal section of the entire kiln. Fig. 2 is a cross-section of the same, showing the method of suspension. Fig. 3 is a plan view of the kiln; and Fig. 4, a section of the lining of the kiln, on an enlarged scale, at the place where the compressed air is introduced into the channels in the lining.

In the form represented in section in Fig. 4 the interior surface of the lining of the kiln is provided with grooves *a*. Thereby ribs or ridges are formed which continually lift the material and let it fall through the flame, which process they continually repeat until the material leaves the kiln. At one part of the kiln (see Fig. 4) cross-borings *c* enter the air-channels *b*, which latter are longitudinally placed and extend part way throughout the length of said kiln. Through these cross-borings *c* compressed air is introduced. This can be done or accomplished by various means. The only requisite condition is that the escape of compressed air should be prevented as much as possible by carefully preventing leakage and that the revolution of the kiln should in no manner further leakage. In the form of construction represented the prevention of leakage is effected by means of an elastic grooved metal split ring *d*, which fits closely against the outer circumference of the kiln and is prevented from revolving with the latter by some suitable arrangement, such as the abutment *e*. This ring *d* must, of course, completely cover the openings of the cross-borings *c*. The compressed-air pipe *f* ends in the ring *d*.

The kiln itself moves in ball-bearings, the stationary boxes of which form parts of a frame *h*, revolving on the pintles *i*. The two outer axle-boxes rest, by means of the screws *k*, upon cradles *j* and can be elevated or lowered by adjusting the nuts *m*. It is thereby possible to give the kiln a greater or less degree of inclination and to thus accelerate or re-

tard the passage of the material being burned through the kiln. The kiln can be caused to revolve by various means. In the present instance it is driven by the cog-wheel *z*.

5 With this novel kiln the process is, in a few words, as follows: The air pressed through the ring *d* and the borings *c* into the channels *b* has no means of escape but through the pores of the lining of the kiln and is
10 therefore forced through these into the interior of the kiln and prevents the lining, by cooling it, from being burned very rapidly. By forcing back into the kiln the heat which
15 penetrates into the lining the air prevents the accumulation of slags on the inner surface of the lining, and thereby the waste of heat, and is itself so intensely heated that it carries oxygen of a very high temperature
20 into the interior of the kiln, by which circumstance the burning process is either considerably accelerated or economy in the draft arrangements is effected.

Having now described my invention, what I claim as new, and desire to protect by Letters Patent, is—

1. A new and improved revolving adjustable kiln having a porous fireproof lining and means in connection with said lining for forcing back into the said kiln its internal
30 heat together with ribs for materially reducing the friction developed between said lining and the burning mass, substantially as in the manner and for the purpose set forth and described.

35 2. A new revolving adjustable kiln having

a porous fireproof lining with means for forcing fresh air therethrough and provided on its inner surface with a plurality of grooves and curved ribs substantially as described.

3. A new revolving adjustable kiln having
40 a porous fireproof lining provided with air-channels and cross-borings in connection therewith, receiving air from without which under pressure is forced through said lining
45 into said kiln, and ribs formed on the inner surface of said lining in which said channels and cross-borings are formed, substantially as described.

4. A new revolving adjustable kiln having
50 a cylindrical body portion, means for revolving the same, a porous fireproof lining therein provided with air-channels and cross-borings in connection therewith, an air-tight elastic grooved ring surrounding said body and covering the outer ends of said borings, substantially
55 as described.

5. A new kiln having a cylindrical body, means for adjusting and revolving the same and a porous fireproof lining within said body provided with air-channels in connection with
60 cross-borings, a grooved split elastic metallic ring surrounding said kiln-body and covering the outer ends of said borings, and ribs formed on the inner surface of said lining, substantially as described.

Berlin this 24th day of March, 1900.

WILHELM LESSING.

In presence of—

HENRY HASPER,

WOLDEMAR HAUPT.