

(19) World Intellectual Property  
Organization  
International Bureau



(43) International Publication Date  
18 August 2005 (18.08.2005)

PCT

(10) International Publication Number  
**WO 2005/075591 A1**

(51) International Patent Classification<sup>7</sup>: **C09J 7/00**,  
B32B 27/00

(74) Agents: **BLANK, Colene, E., H.** et al.; Office of Intellectual Property Counsel, Post Office Box 33427, Saint Paul, Minnesota 55133-3427 (US).

(21) International Application Number:  
PCT/US2005/003191

(81) Designated States (unless otherwise indicated, for every kind of national protection available): AE, AG, AL, AM, AT, AU, AZ, BA, BB, BG, BR, BW, BY, BZ, CA, CH, CN, CO, CR, CU, CZ, DE, DK, DM, DZ, EC, EE, EG, ES, FI, GB, GD, GE, GH, GM, HR, HU, ID, IL, IN, IS, JP, KE, KG, KP, KR, KZ, LC, LK, LR, LS, LT, LU, LV, MA, MD, MG, MK, MN, MW, MX, MZ, NA, NI, NO, NZ, OM, PG, PH, PL, PT, RO, RU, SC, SD, SE, SG, SK, SL, SY, TJ, TM, TN, TR, TT, TZ, UA, UG, US, UZ, VC, VN, YU, ZA, ZM, ZW.

(22) International Filing Date: 2 February 2005 (02.02.2005)

(25) Filing Language: English

(26) Publication Language: English

(30) Priority Data:  
60/541,170 2 February 2004 (02.02.2004) US

(71) Applicant (for all designated States except US): **3M INNOVATIVE PROPERTIES COMPANY** [US/US]; 3M Center, Post Office Box 33427, Saint Paul, Minnesota 55133-3427 (US).

(84) Designated States (unless otherwise indicated, for every kind of regional protection available): ARIPO (BW, GH, GM, KE, LS, MW, MZ, NA, SD, SL, SZ, TZ, UG, ZM, ZW), Eurasian (AM, AZ, BY, KG, KZ, MD, RU, TJ, TM), European (AT, BE, BG, CH, CY, CZ, DE, DK, EE, ES, FI, FR, GB, GR, HU, IE, IS, IT, LT, LU, MC, NL, PL, PT, RO, SE, SI, SK, TR), OAPI (BF, BJ, CF, CG, CI, CM, GA, GN, GQ, GW, ML, MR, NE, SN, TD, TG).

(72) Inventors; and

(75) Inventors/Applicants (for US only): **NIELSEN, John, A.** [US/US]; 3M Center, Post Office Box 33427, Saint Paul, Minnesota 55133-3427 (US). **EMSLANDER, Jeffrey, O.** [US/US]; 3M Center, Post Office Box 33427, Saint Paul, Minnesota 55133-3427 (US). **YARUSSO, David, J.** [US/US]; 3M Center, Post Office Box 33427, Saint Paul, Minnesota 55133-3427 (US).

**Published:**  
— with international search report  
— before the expiration of the time limit for amending the claims and to be republished in the event of receipt of amendments

[Continued on next page]

(54) Title: METHOD OF PRODUCING COLORED GRAPHIC MARKING FILMS

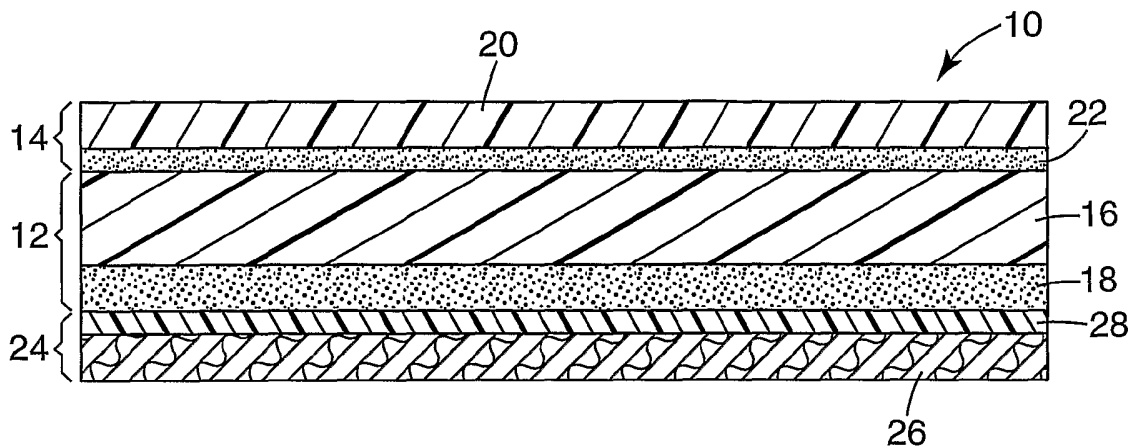

(57) Abstract: The present application is directed to colored films, especially those used as graphic marking films, for example those used in the generation of graphic designs for signage, vehicle markings and the like, and the manufacture thereof. The present application is also directed to methods of making colored films and methods of delivering the films to a customer.

WO 2005/075591 A1



---

*For two-letter codes and other abbreviations, refer to the "Guidance Notes on Codes and Abbreviations" appearing at the beginning of each regular issue of the PCT Gazette.*

## Method of Producing Colored Graphic Marking Films

### **Field**

5 The present application is directed to colored, non-white films, especially those used as graphic marking films.

### **Background**

10 The present application is directed to colored films, especially those used as graphic marking films, for example those used in the generation of graphic designs for signage, vehicle markings and the like, and the manufacture thereof. Generally, these films are adhesive backed, and comprise a base polymeric film layer, an adhesive layer, and optionally a release liner layer in contact with the adhesive layer opposite the polymeric film layer.

15 Such graphic marking films generally fall into two classes: white films which are printed to form the desired color image and pigmented colored films which are used to create colored images by cutting desired shapes from such films. Such pigmented films are made by intimately mixing the desired pigment particles into the polymeric film components. The pigment particles comprise organic or inorganic molecules which absorb certain wavelengths of light and thus impart specific colors. A mixture of pigments  
20 can be used to achieve a specific desired color. Additionally, white films have been laminated to colored transparent films to yield colored films. This has been used on, for example, white reflective sheeting to yield colored reflective sheeting.

25 Printing white film allows a high degree of flexibility in the design of the graphic image, from simple designs to photographic reproductions. Screen printing and a wide variety of 4-color (cyan, magenta, yellow, black) digital printing methods are commonly used.

30 Digital printing on white film to create solid color has several disadvantages. For example the color gamut available from such four color printing processes is more limited than that available by mixing of a much larger starting set of pigments. This is true even for the enhanced systems based on six or more process colors (e.g. systems sold under the

tradename HEXACHROME). Solid fields of color produced by this method are not as uniform as pigmented or screen printed film due to the banding and striation defects typical of these methods. Additionally, it is difficult to achieve sufficient ink density by these techniques for backlit applications.

5 Pigmented films generally have a greater range of colors (Color gamut) and are more uniform in color than printed films. Additionally, a pigmented film has color throughout the thickness of the film, and therefore the color can be viewed from both sides of the film, and scratches and gouges are less evident than if the color is in a layer on the surface. In addition, cut edges have the same color as the film major surface which is  
10 desirable in some applications. Pigmented colored films can be cut, and achieve sharply defined edges by cutting shapes with a knife compared to the edges of printed fields. Additionally, the equipment needed for cutting colored film is inexpensive and readily available in most sign shops.

Colored graphic marking films are available in both opaque and translucent  
15 varieties. The translucent types are used for backlit signage applications (where the light is transmitted through the film to the viewer) while the opaque films are used where the film will be viewed with light reflected off the film. A film is considered opaque if it can effectively hide the color or pattern of the surface on which it is applied. Translucent films transmit a significant portion of light through their thickness but typically scatter that  
20 light diffusely so that the image of the light source used to backlight such films is not apparent to the viewer. The process for producing opaque and translucent pigmented films is similar, the primary difference being in the size and concentration of the pigment particles. Particles large compared to the wavelength of light tend to scatter and reflect light strongly and are useful in making opaque films. Smaller particles scatter light less  
25 and can be use to create transparent or translucent films. Transparent colored films are rarely used in the graphic marking industry but we will define transparent films as those which transmit a significant portion of the light at selected wavelengths with minimal scattering of the light.

The current method for producing solid color graphic marking films comprises  
30 formulating a compound of polymer film components and pigments and fabricating the film by extrusion, calendering, or casting of organosols or plastisols. This system requires

a special formulation of pigments for each color produced. The methods of production are complex such that the production of such films is accomplished by large film manufacturing companies using large scale equipment. The process of changing over from one color to the next is time consuming and generates significant waste. Therefore, efficient production can only be done on relatively large runs of a particular color.

As a result, large minimum order quantities are required by manufacturers to economically produce a custom color. It is expensive to inventory colors which are used infrequently. As a result, the selection of colors readily available to the users is limited.

There is an existing system that allows the custom production of solid color graphic marking film through the sequential application of one or more colored thermal transfer foils to a graphic marking film (see e.g. U.S. Patent Numbers 6,002,416 and 6,014,221). The thermal transfer foils comprise a thin film of pigments in a thermally fusible binder on a carrier film. The colored pigment/binder layer can be transferred to another film through a thermal transfer process.

15

### Summary

It would be desirable to have a system which allows rapid customizable coloration of a graphic marking film which exhibits the advantages of solid colored film but can be produced efficiently in small volume.

In one aspect of the invention, a method of making a colored film is disclosed, comprising providing a base layer comprising a polymeric film, and an adhesive layer on a first major surface of the base layer polymeric film, the base layer having color; providing a transparent layer comprising a polymeric film and an adhesive layer on a first major surface of the transparent layer polymeric film, the transparent layer having color; and laminating the transparent layer to a second major surface of the base layer.

In another aspect of the invention, a colored film is disclosed comprising a transparent layer having a color; and an adhesive layer having color on a first major surface of the transparent layer.

In another aspect of the invention, a method of making a colored film is disclosed comprising providing a base layer comprising a polymeric film, and an adhesive layer on a

30

first major surface of the base layer polymeric film, the base layer having color; and printing an ink color layer on a surface of the base layer with a non-contact digital printing method.

5 In another aspect of the invention, a colored film is disclosed comprising a base layer comprising a polymeric film, and an adhesive layer on a first major surface of the base layer polymeric film, the base layer having color; and a transparent layer comprising a polymeric film and an adhesive layer on a first major surface of the transparent layer polymeric film, the transparent layer having color, wherein the transparent layer has a minimum light transmission in the range of visible light wavelengths of greater than 10%.

10 In another aspect of the invention, a colored film is disclosed comprising a base layer comprising a polymeric film, and an adhesive layer on a first major surface of the base layer polymeric film, the base layer having color; and an ink color layer on a surface of the base layer deposited with a non-contact digital printing method, wherein the color shift between the colored film and the base layer is less than 40 DE\* units.

15 In another aspect of the invention, a colored film is disclosed comprising a transparent layer; an ink layer on a major surface of the transparent layer; and an adhesive layer on the ink layer opposite the transparent layer.

### Brief Description of the Drawings

20 Figure 1 is a cross sectional view of a colored film made using an embodiment of the present invention.

Figure 2 is a cross sectional view of a colored film made using an embodiment of the present invention.

25 Figure 3 is a cross sectional view of a colored film embodiment of the present invention.

### Detailed Description

The present invention is directed to a method of manufacturing colored films which allows for the generation of a large number of colors from a small starting

inventory. Furthermore, the processes used for generating the colored film can be accomplished with equipment which is readily available in the graphic marking industry.

Generally, the colored films are solid colored films. A solid color is defined, for the purpose of the present application, as a single color across the major surface of the film, as contrasted to a defined graphic image, which has color in areas to create an image.

Generally, the base layer used in the present invention is adhesive backed, and comprises a polymeric film layer, and an adhesive layer. In certain embodiments, the base layer comprises a release liner layer in contact with the adhesive layer opposite the polymeric film layer. The base layer has a color. Generally, the base layer polymeric film layer may be a pigmented colored film, a printed film with color on a major surface of the polymeric film layer (i.e. a white film with a color printed on a major surface opposite the adhesive layer, or a transparent base polymeric film with printing on a major surface and the adhesive layer on the printed surface opposite the base polymeric film), or a transparent film with a colored adhesive.

The base layer may have printed color if the printed color is sufficiently uniform such as is produced by, for example, screen printing.

The polymeric film can be any polymeric film. Generally, the polymeric film is polyvinyl chloride (commonly called "vinyl") film. Specific examples include vinyl films made by casting from organosol or plastisol mixtures or by calendaring or by extrusion. Examples of such films are sold under the tradename SCOTCHCAL 7725 Graphic Marking Film available from the 3M Company, St. Paul, MN. The polymeric film may be opaque, translucent or transparent.

In addition to the polymeric film, the base layer additionally comprises an adhesive layer. The adhesive layer may be, for example, a heat activated adhesive or a pressure sensitive adhesive. In general, the adhesive layer is a pressure sensitive adhesive, i.e. an adhesive which requires no activation and adheres upon contact with the target substrate. Modifications to such pressure sensitive adhesive layers are known which provide light adhesion upon initial contact followed by more aggressive adhesion after the application of pressure. Such adhesives have been referred to as pressure activated adhesives. Examples include the adhesives sold under the tradename CONTROLTAC adhesives available on graphic marking films from 3M Company, St. Paul, MN. Other functions

may also be present in the adhesive such as microstructured air channels to allow the release of air from trapped bubbles, easing application. Examples of such adhesives are those adhesives sold under the tradename COMPLY performance adhesives, marketed by the 3M Company, St. Paul, MN.

5           In other embodiments, heat activated adhesives are used in these graphic marking applications. In the case of a heat activated adhesive, the release liner layer may not be necessary.

10           The colored film may additionally comprise a release liner. Release liners generally include a release liner base and a release layer. The release liner base may comprise a paper, polymer coated paper, or a polymeric film, such as a polyester film. The release layer is chosen so that the adhesive removes easily from the release liner. Examples of release layers include silicone chemistries, as are widely known in the pressure sensitive adhesive art.

15           In one embodiment of the invention, a set of colored base layers is combined with a set of transparent colored films to produce a wide variety of colors by lamination. Lamination is defined as the process of bringing two layers of materials into intimate contact to form a bonded layered structure. For example, a set of 30 base polymeric films and a set of 20 colored transparent films can be combined to obtain 600 different colored films. Even more colors may be achieved through the lamination of more than one  
20           transparent colored film to the base layer. An embodiment of the resulting colored film is shown in Figure 1. Figure 1 shows colored film 10, which comprises a colored base layer 12 and a colored transparent layer 14. Base layer 12 comprises a polymeric film 16 and an adhesive layer 18. The transparent layer 14 comprises a transparent polymeric film 20 and an adhesive layer 22. Additionally, in the embodiment shown in Figure 1, the colored film  
25           10 comprises a release liner 24. Release liner 24 comprises a release liner base 26 and a release layer 28.

30           Another embodiment of this is shown in Figure 2. Figure 2 shows colored film 200, which comprises a colored transparent polymeric film 220 and a colored adhesive layer 222. Additionally, in the embodiment shown in Figure 2, the colored film 200 comprises a release liner 224. Release liner 224 comprises a release liner base 226 and a release layer 228.



In some embodiments, the transparent layer 14 or the transparent film 220 has a minimum light transmission in the range of visible light wavelengths of greater than 10%, for example greater than 20%. In some embodiments, the transparent layer 14 or the transparent film 220 has a minimum light transmission in the range of visible light wavelengths of greater than 30%, for example greater than 40% and in specific embodiments greater than 50%.

In a specific example of such a system, the base films are of the traditional adhesive backed graphics marking film construction, comprising a layer of pigmented polymeric film, an adhesive (preferably a pressure sensitive or pressure activated adhesive) layer, and a release liner layer. The base films may be either opaque or translucent. The transparent films are of similar construction but the pigmentation of the film is such that, although colored, the film remains transparent.

The generation of a specific color is accomplished by the lamination of the transparent colored film onto the base film, using an adhesive between the transparent film and the base film to provide the adhesion, or laminate, of one film to the other.

The lamination can be accomplished by any of the methods known in the industry, including the use of a laminating machine in which the two films are brought together under pressure as the films pass between two nip rollers wherein the rollers are pressed toward one another by hydraulic, pneumatic, spring force or other means to create a laminating pressure. The films may also be laminated by hand application of pressure with a squeegee or similar tool. Such hand lamination may be assisted by the use of water or a detergent water mixture. The squeegee action pushes the water out and brings the adhesive and film surfaces into contact. After drying, the bond reaches its maximum strength.

The colors and densities of the transparent films are chosen to create the desired color of the resulting colored film.

The resulting colored film can then be cut in the same way as with solid pigmented film to produce a graphic. Both opaque and translucent films can be made by this method simply by choosing an opaque or translucent base film, respectively.

In another embodiment, the base film comprises a colored adhesive layer on a release liner with no polymeric film layer. The transparent film, in this case, comprises a transparent colored polymeric film with no adhesive or liner layer. The transparent film is laminated to the colored adhesive layer and its liner to produce the finished film in the desired color. A colored adhesive is made in a similar way as the pigmented films, mixing the pigment into the adhesive prior to coating.

In addition to the already described method of providing the transparent color of the transparent film by pigmenting throughout the polymeric film layer of the transparent film, the color of said transparent film can alternatively be provided as a printed layer on the top surface of the transparent film or as a layer between the polymeric film layer and the adhesive layer of the transparent film or by pigmenting the adhesive layer of the transparent film.

In a specific embodiment, the adhesive layer of the transparent film is a pressure sensitive adhesive so that the lamination can be accomplished by simple lamination equipment such as that used in the industry to apply application tapes to graphic marking films or that used to apply clear transparent films to printed graphics for protection of the color layer. In other embodiments, the adhesive of the transparent film is a heat activated adhesive in which case a heated laminator would be required.

The laminating equipment required is readily available in most graphic production facilities which would use colored graphic marking films so that the custom color can be created on demand by the user.

In another embodiment of the invention, various non-contact digital printing methods are available such as inkjet printing to add color to a base layer. In such systems, a set of process print colors is used. These colors are typically cyan, magenta, yellow, and black. Dots of various densities and sizes of these colors are delivered to the surface. The dots are small enough that at the designed viewing distance, one cannot perceive the individual dots and instead, one perceives a color which is the resultant of the subtractive effects of all the dots taken together on the light reflecting off the surface. An embodiment of the resulting colored film is shown in Figure 3. Figure 3 shows colored film 300, which comprises a base layer 312 and an ink layer 314. Base layer 312 comprises a polymeric film 316 and an adhesive layer 318. Additionally, in the

embodiment shown in Figure 3, the colored film 300 comprises a release liner 324. Release liner 324 comprises a release liner base 326 and a release layer 328.

5 In this embodiment of the invention, a digital printing process may be used to apply inks as a solid field of color on the surface of a pigmented base film to shift the color. (Other modified process color systems employing more than four colors may also be used.) This method allows one to readily select a desired color in software and the printer can deliver the desired amount of printed film with no waste. Preferably, the inks used are transparent inks although the desired effect may be achieved to a large degree with partially opaque inks if the ink dots do not cover the base film so the eye will  
10 perceive the desired color resulting from the ink and the base film.

The colors and densities of the printed inks are chosen to create an apparent color of the composite which is similar to but shifted in color from that of the base film. Both opaque and translucent films can be made by this method simply by choosing an opaque or translucent base film, respectively.

15 Any of the non-contact digital printing platforms commonly used in this industry may be used including ink jet printing (with solvent based, ultraviolet radiation curable, or water based inks).

The film will be printed using a printer suitable for the printing method desired. In some embodiments, the printer may include software to assist in selection of the colored  
20 film to be printed and adjustment of the print densities to achieve the desired color. For example, a user could input a desired end color, and the software would recommend a starting base film to the user, and then print the appropriate color and density of the color to achieve the end color. In certain embodiments, the printer would include a sensor for measuring the color of the base film. The software would then automatically print the  
25 correct density of the various ink colors to produce the desired color on the particular measured base film.

In some embodiments, a clear protective overlamine film or a protective clear coating may be applied over the printed layer to protect it as is commonly done with printed graphic films.

The degree of color shifting from the base film color can be continuously varied by control of the printer settings. There is very little wasted material with this system since the printer can start and stop printing at any point without wasting ink or film material. The color gamut available is just as large as that available with pigmented film technology since one can use any pigmented base film. However, because of the ability to shift the color with the printing, a wide variety of shade variations can be achieved from relatively small set of films. Since there is color throughout the film which is not very different from that of the desired color, scratches and gouges in the film will not be as evident as they would if the color were produced by printing on the surface of white film. In the event of color fade of the color-adjusting layer, the graphics film will fade back to the color of the base film, rather than to a much more conspicuous white. The uniformity of the color appearance will be better than for digital printing of solid colors on white film because printer defects such as banding and striations will not be as visible due to the lack of contrast between the base film color and the composite color. The uniformity of the light transmission for translucent applications is nearly as good as with conventional translucent pigmented films because the light transmission is largely controlled by the base film rather than the printed color layer. The digital printing equipment required is readily available in many graphic manufacturing facilities which use colored graphic marking films so that the custom color can be created on demand by the user.

In another embodiment, a transparent colored film is printed and then the printed surface is laminated to an adhesive on a liner to create the final product. The adhesive would be clear or diffusely light scattering for translucent applications and white for opaque applications. The advantage of this scheme is that the defects in the print pattern may be even less visible because they are in the layer under the transparent color.

Color can be measured quantitatively using a spectrophotometer with a standardized light source for illumination and a standardized acceptance angle for capturing the reflected light. One such instrument commonly used in the industry is sold under the tradename GRETAG Model SPM50, manufactured by GretagMacbeth LLC, New Windsor, NY . The measured color can be expressed by three independent parameters. One system for doing so is the CIELAB system. In this system, the L\* axis characterizes the overall brightness or luminance of the system, while the position in the a\*-b\* plane represents the hue and chroma. The a\* axis represents the balance between

green and red with green in the negative direction and red in the positive direction. The b\* axis represents the balance between yellow and blue with blue in the negative direction and yellow in the positive direction. ("The Reproduction of Color: in Photography, Printing, and Television," R.W.G. Hunt, 4<sup>th</sup> edition, Fountain Press, Tolworth, England, 1987.) Differences between two colors (1 and 2) can be expressed by the distance between the points in this three dimensional space representing the two colors, represented by the symbol DE\*, where

$$DE^* = \sqrt{(a_1^* - a_2^*)^2 + (b_1^* - b_2^*)^2 + (L_1^* - L_2^*)^2}$$

In the present invention, the DE\* between the initial base color and the final colored film is no greater than 40, for example no greater than 20. In some embodiments, the DE\* is no greater than 10 and in certain embodiment, the DE\* is no greater than 5.

The resulting colored film may be cut into a desired form using a variety of methods. Exemplary methods include electronic cutting, die cutting or thermal kiss cutting. In electronic cutting, a knife is driven under computer control to cut out the desired shape. In die cutting, a die formed in the desired shape is pressed into the film to cut it. In thermal kiss cutting, a hot die is pressed briefly against the film, cutting by a combination of melting and pressure. Generally, the cutting method cuts through the polymeric film and the adhesive but not through the release liner.

After cutting, the unwanted film material is peeled away (known as weeding) and discarded. A sheet of application tape comprising a paper or film backing and a pressure sensitive adhesive is applied to the cut parts, bonding them in the appropriate positions on the application tape. To apply the graphic to the target substrate, the liner is removed, causing the cut parts to remain on the adhesive surface of the application tape, while the application tape and its attached cut parts are applied to the target substrate. After applying pressure to ensure the adhesion of the cut parts to the substrate, the application tape is removed and discarded. This process is described in detail in U.S. Patent Number 4,467,525.

Additionally, a method of doing business is presented. In this method, a customer, for example a sign shop, is presented with a system that allows rapid customizable coloration of a graphic marking film which exhibits the advantages of solid colored film but can be produced efficiently and economically in small volume.

In such a system, the color gamut available is just as large as that available with pigmented film technology since one can use any pigmented base film. In addition, the base film color can be shifted to a large number of shades of color with either a transparent sheet having color or an ink layer. Therefore, a wide variety of colors can be achieved  
5 from a relatively small set of base films.

Additionally, if pigmented films are used, there is color throughout the film which is not substantially different from that of the desired color, therefore scratches and gouges in the film will not be as evident as they would if the color were produced by printing on the surface of white film. The customer would also receive uniformity of the color nearly  
10 as good as or as good as with conventional pigmented film and uniformity of the light transmission for translucent applications nearly as good as or as good as with conventional translucent pigmented films.

The system includes a method for allowing a customer to choose a color for a resulting film. The customer may choose the color from a selection on site. For example,  
15 the customer may view a book of base films and a book of transparent films, and may overlay the base film until they reach a desired color. In another embodiment, the customer may view a book with printed color samples. In other embodiments, the customer has a preselected color chosen before seeing the color choices.

The colored film is then custom made for the customer in a short time, or the  
20 customer can custom-make the colored film him- or herself. The customer may also order the custom colored film from a regional source. The regional source is, for example, a location within a defined geographic area. For example, the United States may be separated into a number of geographic clusters (e.g. northeast, midwest, southwest), and one regional source is identified for each cluster. The custom color is then manufactured  
25 using a method of the present invention. In either embodiment, the film is made quickly for the customer, for example within 48 hours and in specific embodiments within 24 hours.

The method allows for a small inventory to be on hand for a large number of desired colored films. The customer interface site or geographic distribution center need  
30 only keep a set number of base films and then have either a set number of colored adhesives, a set number of transparent films or a set number of inks, as well as the

machinery for manufacturing the colored film (e.g. a laminator or a non-contact digital printer).

**Examples**

5 These examples are merely for illustrative purposes only and are not meant to be limiting on the scope of the appended claims.

Certain samples were measured for the DE\* as detailed above.

Laminated Samples

Table 1

Sample	DE* vs base film	L*	a*	b*
base green film	(reference)	49.04	-38.60	19.77
With yellow transparent layer	<b>3.88</b>	48.14	-37.17	23.26
with blue transparent layer	<b>3.73</b>	46.85	-41.19	18.22

10 Printed Samples

Table 2

Sample ID	DE* vs base film	L*	a*	b*
base green film	(reference)	52.25	-47.18	12.28
with yellow print	<b>6.11</b>	51.73	-48.22	18.32
with cyan print	<b>3.64</b>	50.47	-48.97	9.28

15 Various modifications and alterations of the present invention will become apparent to those skilled in the art without departing from the spirit and scope of the invention.

What is Claimed is:

1. A method of making a colored film comprising  
providing a base layer comprising a polymeric film, and an adhesive layer on a  
first major surface of the base layer polymeric film, the base layer having color;  
5 providing a transparent layer comprising a polymeric film and an adhesive layer on  
a first major surface of the transparent layer polymeric film, the transparent layer having  
color; and  
laminating the transparent layer to a second major surface of the base layer.
- 10 2. The method of claim 1 wherein the base layer further comprises a release liner on  
the adhesive layer opposite the polymeric film.
3. The method of claim 1 wherein the base layer adhesive is a pressure sensitive  
adhesive on a surface opposite the transparent film.
- 15 4. The method of claim 1 wherein the transparent layer is laminated to the base layer  
with a pressure sensitive adhesive.
5. The method of claim 1 wherein the transparent layer is laminated to the base layer  
20 with a heat activated adhesive.
6. The method of claim 1 further comprising cutting the colored film.
7. The method of claim 6 wherein the colored film is die cut.
- 25 8. The method of claim 6 wherein the colored film is electronically cut.
9. The method of claim 6 wherein the colored film is thermal kiss cut.
- 30 10. The method of claim 1 wherein the base layer polymeric film is printed.
11. The method of claim 1 wherein the base layer polymeric film is a pigmented film.



12. The method of claim 1 wherein the transparent layer polymeric film is printed.
13. The method of claim 1 wherein the transparent layer polymeric film is a pigmented  
5 film.
14. The method of claim 1 wherein the base layer polymeric film is uncolored and transparent, and the base film color is in the base layer adhesive.
- 10 15. The method of claim 1 wherein the transparent layer color is in the transparent layer adhesive.
16. The method of claim 1 wherein the base layer polymeric film is transparent.
- 15 17. The method of claim 1 wherein the base layer polymeric film is translucent.
18. The method of claim 1 wherein the base layer polymeric film is opaque.
19. The method of claim 1 wherein the colored film is a uniform color.
- 20 20. A colored film comprising  
a transparent layer having a color; and  
an adhesive layer having color on a first major surface of the transparent layer.
- 25 21. The colored film of claim 20 wherein the transparent layer has a minimum light transmission in the range of visible light wavelengths of greater than 50%.
22. The colored film of claim 20 wherein the transparent layer has a minimum light transmission in the range of visible light wavelengths of greater than 40%.

30

23. The colored film of claim 20 wherein the transparent layer has a minimum light transmission in the range of a visible light wavelengths of greater than 30%.
24. The colored film of claim 20 wherein the transparent layer has a minimum light transmission in the range of a visible light wavelengths of greater than 20%.
- 5 25. The colored film of claim 20 wherein the transparent layer has a minimum light transmission in the range of visible light wavelengths of greater than 10%.
26. A method of making a colored film comprising  
providing a transparent film having a color; and  
laminating the transparent film to an adhesive layer, wherein the adhesive layer has  
10 a color.
27. A method of making a colored film comprising  
providing a base layer comprising a polymeric film, and an adhesive layer on a  
first major surface of the base layer polymeric film, the base layer having color; and  
15 printing an ink color layer on a surface of the base layer with a non-contact digital  
printing method.
28. The method of claim 27 wherein the base layer further comprises a release liner on  
the adhesive layer opposite the polymeric film  
20
29. The method of claim 27 wherein the base layer adhesive is a pressure sensitive  
adhesive on a surface opposite the transparent film.
30. The method of claim 27 wherein the ink color layer is a continuous layer.  
25
31. The method of claim 27 wherein the ink color layer is a discontinuous layer.
32. The method of claim 27 wherein the ink color layer is transparent.
- 30 33. The method of claim 27 further comprising cutting the colored film.

34. The method of claim 33 wherein the colored film is die cut.
35. The method of claim 33 wherein the colored film is electronically cut.
- 5 36. The method of claim 33 wherein the colored film is thermal kiss cut
37. The method of claim 27 wherein the base layer polymeric film is printed.
38. The method of claim 27 wherein the base layer polymeric film is a pigmented film.
- 10 39. The method of claim 27 wherein the color shift between the colored film and the base layer is less than 40 DE\* units.
40. The method of claim 27 wherein the color shift between the colored film and the base layer is less than 20 DE\* units.
- 15 41. The method of claim 27 wherein the color shift between the colored film and the base layer is less than 10 DE\* units.
- 20 42. The method of claim 27 wherein the color shift between the colored film and the base layer is less than 5 DE\* units.
43. The method of claim 27 wherein the digital printing method is inkjet printing.
- 25 44. The method of claim 43 wherein the inkjet printing uses an ultraviolet radiation curable ink.
45. The method of claim 43 wherein the inkjet printing uses a solvent based ink.
- 30 46. The method of claim 43 wherein the inkjet printing uses a water based ink.
47. The method of claim 43 wherein the digital printing method is thermal inkjet.

48. The method of claim 43 wherein the digital printing method is piezo inkjet.
49. The method of claim 27 wherein the colored film is a solid color.
- 5  
50. The method of claim 27 wherein the ink color layer is selected by computer software.
51. A colored film comprising  
10 a base layer comprising a polymeric film, and an adhesive layer on a first major surface of the base layer polymeric film, the base layer having color; and  
a transparent layer comprising a polymeric film and an adhesive layer on a first major surface of the transparent layer polymeric film, the transparent layer having color, wherein the transparent layer has a minimum light transmission at a visible light  
15 wavelength of greater than 50%.
52. A colored film comprising  
a base layer comprising a polymeric film, and an adhesive layer on a first major surface of the base layer polymeric film, the base layer having color; and  
20 an ink color layer on a surface of the base layer deposited with a non-contact digital printing method,  
wherein the color shift between the colored film and the base layer is less than 20 DE\* units.
- 25 53. A colored film comprising  
a transparent layer;  
an ink layer on a major surface of the transparent layer; and  
an adhesive layer on the ink layer opposite the transparent layer.
- 30

1/1

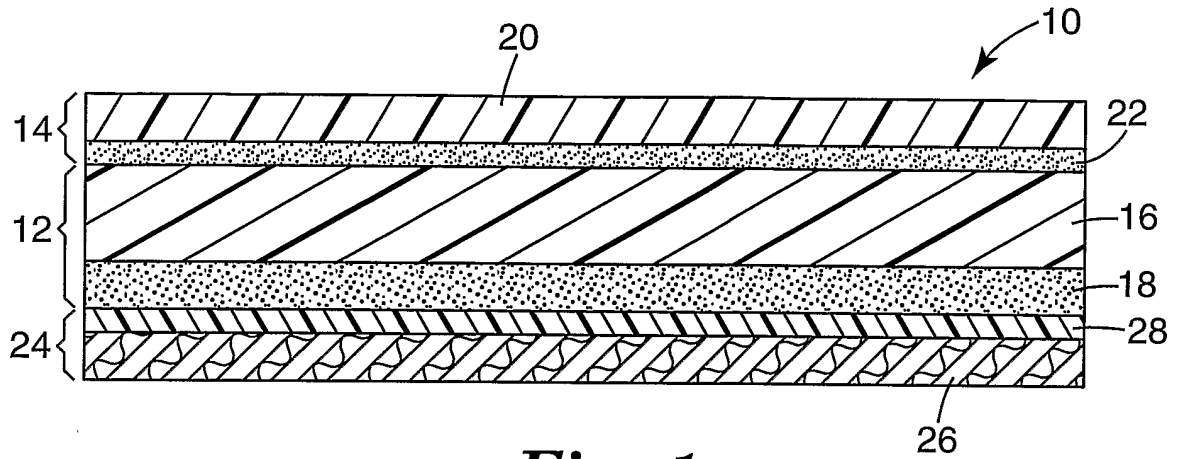

*Fig. 1*

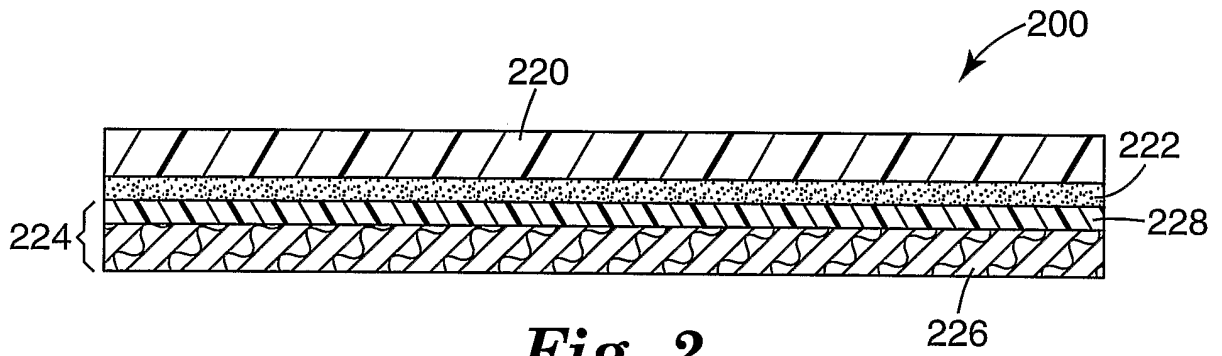

*Fig. 2*

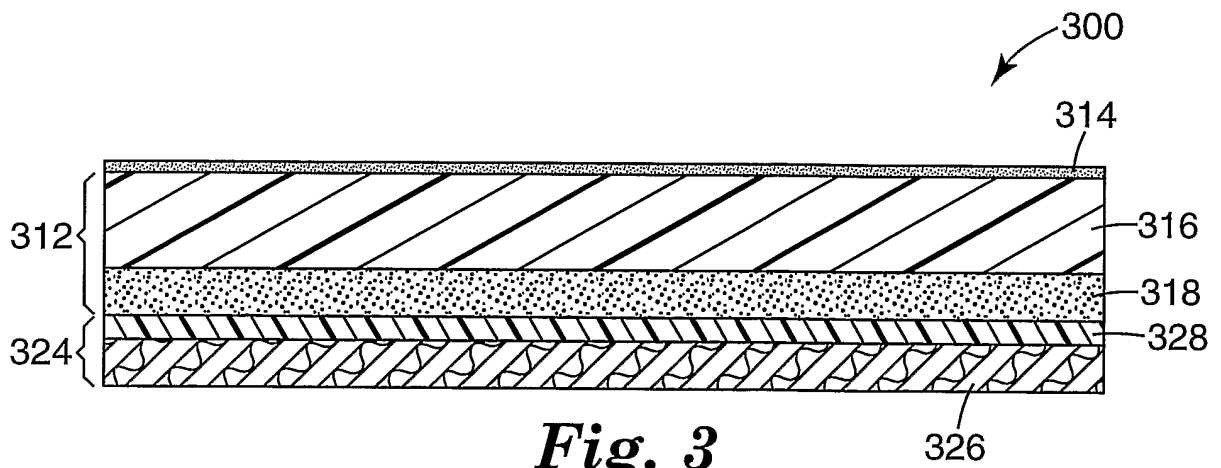

*Fig. 3*

INTERNATIONAL SEARCH REPORT

International Application No  
PCT/US2005/003191

**A. CLASSIFICATION OF SUBJECT MATTER**  
IPC 7 C09J7/00 B32B27/00

According to International Patent Classification (IPC) or to both national classification and IPC

**B. FIELDS SEARCHED**  
Minimum documentation searched (classification system followed by classification symbols)  
IPC 7 C09J B32B

Documentation searched other than minimum documentation to the extent that such documents are included in the fields searched

Electronic data base consulted during the international search (name of data base and, where practical, search terms used)  
EPO-Internal, WPI Data, PAJ

**C. DOCUMENTS CONSIDERED TO BE RELEVANT**

Category °	Citation of document, with indication, where appropriate, of the relevant passages	Relevant to claim No.
X	GB 1 594 438 A (STAUFFER CHEMICAL CO) 30 July 1981 (1981-07-30) figure 4	1-19,51
X	US 3 468 744 A (THOMAS J. REINHART) 23 September 1969 (1969-09-23) figures 1,2	1-19,51
X	PATENT ABSTRACTS OF JAPAN vol. 1998, no. 10, 31 August 1998 (1998-08-31) & JP 10 143072 A (KYOWA TOKUSHU INSATSU KK), 29 May 1998 (1998-05-29) abstract	1-19,51
	----- -/--	

Further documents are listed in the continuation of box C       Patent family members are listed in annex.

° Special categories of cited documents :

*A* document defining the general state of the art which is not considered to be of particular relevance	*T* later document published after the international filing date or priority date and not in conflict with the application but cited to understand the principle or theory underlying the invention
*E* earlier document but published on or after the international filing date	*X* document of particular relevance; the claimed invention cannot be considered novel or cannot be considered to involve an inventive step when the document is taken alone
*L* document which may throw doubts on priority claim(s) or which is cited to establish the publication date of another citation or other special reason (as specified)	*Y* document of particular relevance; the claimed invention cannot be considered to involve an inventive step when the document is combined with one or more other such documents, such combination being obvious to a person skilled in the art.
*O* document referring to an oral disclosure, use, exhibition or other means	*&* document member of the same patent family
*P* document published prior to the international filing date but later than the priority date claimed	

Date of the actual completion of the international search <b>22 July 2005</b>	Date of mailing of the international search report <b>01. 08. 2005</b>
--	---

Name and mailing address of the ISA European Patent Office, P.B. 5818 Patentlaan 2 NL - 2280 HV Rijswijk Tel. (+31-70) 340-2040, Tx. 31 651 epo nl, Fax: (+31-70) 340-3016	Authorized officer <b>Schmitz, V</b>
--	---

5

## INTERNATIONAL SEARCH REPORT

International Application No  
PCT/US2005/003191

## C.(Continuation) DOCUMENTS CONSIDERED TO BE RELEVANT

Category °	Citation of document, with indication, where appropriate, of the relevant passages	Relevant to claim No.
X	PATENT ABSTRACTS OF JAPAN vol. 2000, no. 13, 5 February 2001 (2001-02-05) & JP 2000 303033 A (SEKISUI CHEM CO LTD), 31 October 2000 (2000-10-31) abstract -----	1-19,51
X	PATENT ABSTRACTS OF JAPAN vol. 1999, no. 14, 22 December 1999 (1999-12-22) & JP 11 245347 A (SEKISUI CHEM CO LTD), 14 September 1999 (1999-09-14) abstract -----	1-19,51
X	PATENT ABSTRACTS OF JAPAN vol. 2000, no. 12, 3 January 2001 (2001-01-03) & JP 2000 265129 A (SEKISUI CHEM CO LTD), 26 September 2000 (2000-09-26) abstract -----	1-19,51
X	PATENT ABSTRACTS OF JAPAN vol. 2000, no. 26, 1 July 2002 (2002-07-01) & JP 2001 253033 A (SEKISUI CHEM CO LTD), 18 September 2001 (2001-09-18) abstract -----	1-19,51
X	EP 1 158 315 A (NIPPON CARBIDE KOGYO KABUSHIKI KAISHA) 28 November 2001 (2001-11-28) figure 1 -----	1-19,51
X	PATENT ABSTRACTS OF JAPAN vol. 1996, no. 05, 31 May 1996 (1996-05-31) & JP 08 025590 A (BANDO CHEM IND LTD), 30 January 1996 (1996-01-30) abstract -----	27-50,52
X	PATENT ABSTRACTS OF JAPAN vol. 014, no. 539 (C-0782), 28 November 1990 (1990-11-28) & JP 02 227480 A (DAINIPPON INK & CHEM INC), 10 September 1990 (1990-09-10) abstract -----	27-50,52
X	DE 41 21 599 A1 (ALKOR GMBH KUNSTSTOFFE, 8000 MUENCHEN, DE) 7 January 1993 (1993-01-07) column 7, line 10 - line 53; figures 2-4 -----	27-50,52
	-/--	

## INTERNATIONAL SEARCH REPORT

International Application No  
PCT/US2005/003191

## C.(Continuation) DOCUMENTS CONSIDERED TO BE RELEVANT

Category °	Citation of document, with indication, where appropriate, of the relevant passages	Relevant to claim No.
X	WO 02/077115 A (3M INNOVATIVE PROPERTIES COMPANY; SAKURAI, AIZO; CHISAKA, HAJIME; MORI) 3 October 2002 (2002-10-03) figure 2; examples -----	27-50,52
X	US 6 200 647 B1 (EMSLANDER JEFFREY O ET AL) 13 March 2001 (2001-03-13) figure 3; examples -----	27-50,52
X	US 2001/049008 A1 (NELSON STEPHEN G) 6 December 2001 (2001-12-06) paragraph '0010! - paragraph '0014!; figure 1 -----	27-50,52



# INTERNATIONAL SEARCH REPORT

International application No.  
PCT/US2005/003191

## Box II Observations where certain claims were found unsearchable (Continuation of item 2 of first sheet)

This International Search Report has not been established in respect of certain claims under Article 17(2)(a) for the following reasons:

1.  Claims Nos.:  
because they relate to subject matter not required to be searched by this Authority, namely:
  
2.  Claims Nos.: **partially 1-53**  
because they relate to parts of the International Application that do not comply with the prescribed requirements to such an extent that no meaningful International Search can be carried out, specifically:  
**see FURTHER INFORMATION sheet PCT/ISA/210**
  
3.  Claims Nos.:  
because they are dependent claims and are not drafted in accordance with the second and third sentences of Rule 6.4(a).

## Box III Observations where unity of invention is lacking (Continuation of item 3 of first sheet)

This International Searching Authority found multiple inventions in this international application, as follows:

**see additional sheet**

1.  As all required additional search fees were timely paid by the applicant, this International Search Report covers all searchable claims.
  
2.  As all searchable claims could be searched without effort justifying an additional fee, this Authority did not invite payment of any additional fee.
  
3.  As only some of the required additional search fees were timely paid by the applicant, this International Search Report covers only those claims for which fees were paid, specifically claims Nos.:  
**1-19, 51, 27-50, 52**
  
4.  No required additional search fees were timely paid by the applicant. Consequently, this International Search Report is restricted to the invention first mentioned in the claims; it is covered by claims Nos.:

### Remark on Protest

- The additional search fees were accompanied by the applicant's protest.
- No protest accompanied the payment of additional search fees.

**FURTHER INFORMATION CONTINUED FROM PCT/ISA/ 210**

Continuation of Box II.2

Claims Nos.: partially 1-53

Present claims 1-53 relate to an extremely large number of possible products and/or methods. In fact, the claims contain so many options, variables, possible permutations and provisos that a lack of clarity (and conciseness) within the meaning of Article 6 PCT arises to such an extent as to render a meaningful search of the claims impossible. Consequently, the search has been carried out for those parts of the application which do appear to be clear (and concise), namely those products and methods recited in the examples and the layer structure recited in the figures 1-3. Additionally claim 20 is restricted to a transparent layer comprising a polymeric film and not to transparent layers in general.

The applicant's attention is drawn to the fact that claims relating to inventions in respect of which no international search report has been established need not be the subject of an international preliminary examination (Rule 66.1(e) PCT). The applicant is advised that the EPO policy when acting as an International Preliminary Examining Authority is normally not to carry out a preliminary examination on matter which has not been searched. This is the case irrespective of whether or not the claims are amended following receipt of the search report or during any Chapter II procedure. If the application proceeds into the regional phase before the EPO, the applicant is reminded that a search may be carried out during examination before the EPO (see EPO Guideline C-VI, 8.5), should the problems which led to the Article 17(2) declaration be overcome.

FURTHER INFORMATION CONTINUED FROM PCT/ISA/ 210

This International Searching Authority found multiple (groups of) inventions in this international application, as follows:

1. claims: 1-19,51

A colored film comprising a base layer comprising a polymeric film and an adhesive layer on a first major surface of the base layer, the base layer having color and a transparent layer comprising a polymeric film and an adhesive layer on a first major surface of the transparent layer, the transparent layer having color. Additionally a method of making said film is disclosed.

---

2. claims: 27-50,52

A colored film comprising a base layer comprising a polymeric film and an adhesive layer on a first major surface of the base layer, the base layer having color and an ink color layer on a surface of the base layer deposited with a non-contact digital printing method. Additionally a method of making this film is disclosed.

---

3. claims: 20-26

A colored film comprising a transparent layer having a color and an colored adhesive layer on a first major surface of the transparent layer. A method of making the film is disclosed, also.

---

4. claim: 53

A colored film comprising a transparent layer, an ink layer on a major surface of the transparent layer and an ink layer opposite the transparent layer.

---

## INTERNATIONAL SEARCH REPORT

Information on patent family members

International Application No  
PCT/US2005/003191

Patent document cited in search report		Publication date	Patent family member(s)	Publication date
GB 1594438	A	30-07-1981	AU 517398 B2	30-07-1981
			AU 3222378 A	12-07-1979
			BE 864000 A2	16-08-1978
			CA 1094804 A1	03-02-1981
			CH 624886 A5	31-08-1981
			DE 2805126 A1	24-08-1978
			FR 2380879 A1	15-09-1978
			IL 53709 A	30-11-1980
			IT 1102369 B	07-10-1985
			JP 53102983 A	07-09-1978
			NL 7800346 A	22-08-1978
			NO 780089 A	21-08-1978
			SE 7801795 A	18-08-1978
US 3468744	A	23-09-1969	DE 1569197 A1	02-04-1970
			GB 1133452 A	13-11-1968
			GB 1133451 A	13-11-1968
JP 10143072	A	29-05-1998	NONE	
JP 2000303033	A	31-10-2000	NONE	
JP 11245347	A	14-09-1999	NONE	
JP 2000265129	A	26-09-2000	NONE	
JP 2001253033	A	18-09-2001	NONE	
EP 1158315	A	28-11-2001	JP 2000249817 A	14-09-2000
			EP 1158315 A1	28-11-2001
			US 6520651 B1	18-02-2003
			CN 1337008 A ,C	20-02-2002
			WO 0052502 A1	08-09-2000
JP 08025590	A	30-01-1996	NONE	
JP 02227480	A	10-09-1990	NONE	
DE 4121599	A1	07-01-1993	NONE	
WO 02077115	A	03-10-2002	JP 2002294181 A	09-10-2002
			BR 0208099 A	02-03-2004
			EP 1377646 A1	07-01-2004
			WO 02077115 A1	03-10-2002
			US 2004096630 A1	20-05-2004
US 6200647	B1	13-03-2001	AU 748330 B2	30-05-2002
			AU 2869199 A	24-01-2000
			BR 9911741 A	03-04-2001
			CN 1307525 A	08-08-2001
			EP 1094952 A1	02-05-2001
			JP 2002519225 T	02-07-2002
			WO 0001536 A1	13-01-2000
US 2001049008	A1	06-12-2001	US 6258429 B1	10-07-2001