

Oct. 31, 1950

A. R. HERLACHE
COMBINATION PORTABLE PROJECTION
SCREEN AND CARRYING CASE

2,527,816

Filed Aug. 31, 1946

2 Sheets-Sheet 1

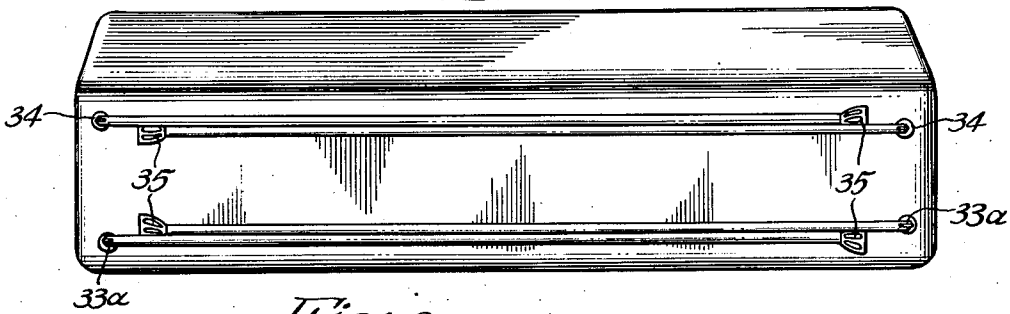
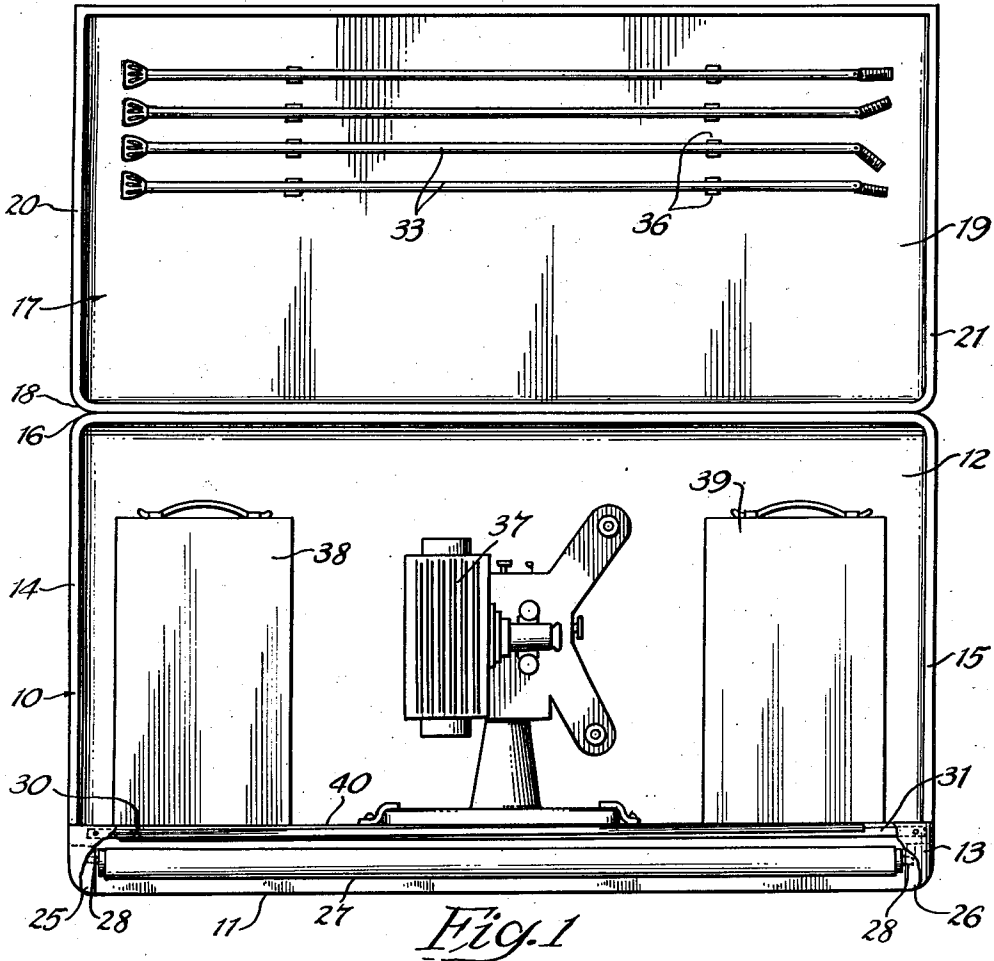

Inventor
Alden R. Herlache
By *John H. Brezina*
Atty.

Oct. 31, 1950

A. R. HERLACHE
COMBINATION PORTABLE PROJECTION
SCREEN AND CARRYING CASE

2,527,816

Filed Aug. 31, 1946

2 Sheets-Sheet 2

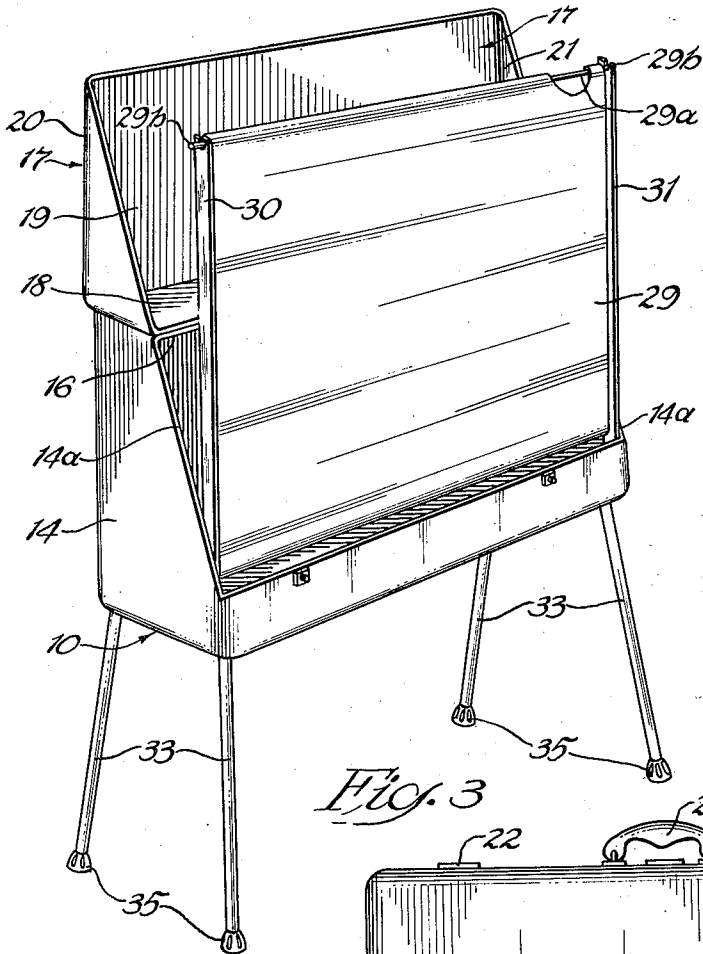

Fig. 3

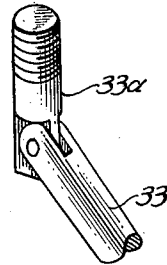

Fig. 5

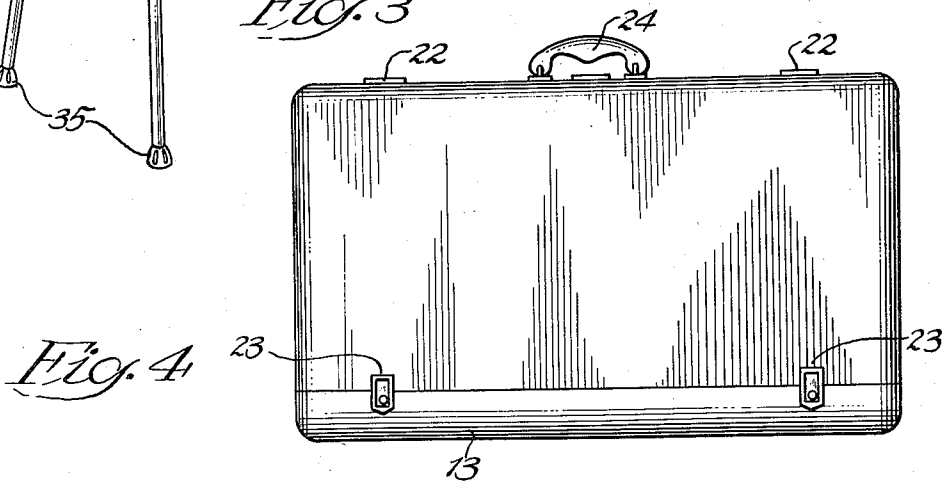

Fig. 4

Inventor
Alden R. Herlache
By *John F. Brazina*
Atty.

UNITED STATES PATENT OFFICE

2,527,816

COMBINATION PORTABLE PROJECTION SCREEN AND CARRYING CASE

Alden R. Herlache, Milwaukee, Wis.

Application August 31, 1946, Serial No. 694,379

3 Claims. (Cl. 160—24)

1

This invention relates to a combination portable carrying case and projection screen.

In the broad field of motion picture projection, particularly in home movie displays and in projections of business, educational and amusement subjects, there is the problem and usual necessity of carrying a separate screen from place to place and to various locations for viewing by audiences; this in addition to the necessity for packing and carrying the projector and needed appurtenances. The transport and packing and unpacking of screens in separate units has resulted in frequent damage to the screen and relatively shorter life thereof in addition to the problem caused by the necessity of carrying and setting up the screen at various locations.

My invention has for one of its objects the elimination of the problem and the provision of an integral device, a portion of which contains and comprises a rollable normally concealed screen and comprises a carrying case provided with easily mountable supporting means for setting up the unit to provide for the screen being maintained at a desirable height and in a flat plane.

A further object of my invention is the provision of a combination carrying case and screen and retractable mounting therefor, including a sectional openable container having a roll screen rotatably and retractably mounted in one of the sections; having pivoted standards adapted to be swung upwardly to support the screen in extended position and having removable leg means to mount the device at desirable height.

Other and further important objects of my invention will be apparent from the following description and appended claims.

This invention (in a preferred form) is illustrated in the accompanying drawings, and one improvement thereof is described in the following specification:

On the drawings:

Fig. 1 is a front elevational view of my device with portions of one side wall broken away and with a closure of the case in open position.

Fig. 2 is a perspective view looking at the bottom of my device and showing the pivotal legs in folded position adjacent the said bottom.

Fig. 3 is a perspective view illustrating my device with the supporting arms and screen in extended position and with the legs in extended supporting position.

Fig. 4 is an elevational view showing the device closed and in usual carrying position.

Fig. 5 is an enlarged fragmentary view of an end portion of one of the legs showing the pivoted threaded end section thereof.

Referring to the drawings, numeral 10 designates a base portion of a case or portable receptacle of substantially rectangular form and hav-

2

ing a bottom 11 and substantially vertically extending relatively high side wall 12 and opposite relatively short side wall 13 connected by opposite end walls 14 and 15, all thereof being connected to bottom 11 in a conventional manner. As indicated in Fig. 3, end walls 14 and 15 are of substantially trapezoidal shape and partially defined by inclined or diagonal edges as indicated at 14-a in Fig. 3. As shown in Figs. 1 and 3, the upper edges of end walls 14 and 15 and side wall 12 are joined together by a rectangular top wall 16 which is secured by suitable fastening elements (not shown) and whose forward straight edge is disposed above the central part of the case.

The inclined rectangular opening so formed is adapted to be closed by a closure, cover or hood 17 composed of top panel 18 and side panel 19 secured perpendicularly to each other and having triangular end walls 20 and 21 secured thereto by suitable fastening elements (not shown). The top panel 18 has secured thereto a pair of spaced apart hinges 22 as illustrated diagrammatically in Fig. 4 so that said cover may be opened and positioned in the position shown in Fig. 1. As shown in Fig. 4, the normally lower long edge portion of cover 17 has a pair of manually releasable locks or clips 23 secured thereon with cooperating interlocking elements of conventional form secured on the outer face of short side wall 13. The top panel 16 preferably is provided with a bail-like handle 24 suitably secured thereto as indicated in Fig. 4.

Suitably secured at opposite ends of the case and at the corners formed by end walls 14 and 15 and bottom 10 and near the side wall 13 (which is shown as broken away in Fig. 1) are a pair of mounting brackets 25 and 26, which brackets are provided with opposed upwardly and inwardly opening slots (not shown) which receive the end pins or studs of a roller. A spring impelled roller 27, of a form substantially similar to a curtain roller, carries end studs or pins 28 which are journaled in the recesses of brackets 25 and 26, one thereof being removable though flat and not rotatable as in the case in rollers of window shades.

A flexible projection screen 29 of conventional type has one inner edge suitably secured to roller 27 in the usual manner and said screen preferably has a grippable hemmed or tunnelled edge 29-a (Fig. 3) in which is mounted a suitable bar or rod (not shown) whose ends normally project beyond the ends of such hemmed edge 29-a.

As illustrated in Fig. 1, a pair of elongated arms, standards or supports 30 and 31, preferably made of metal, have one apertured end of each thereof pivoted by means of suitable rivet to the upper apertured ends of metal brackets

25 and 26 respectively, said pivotal connections being shown in the lower part of Fig. 1. Said supporting arms 30 and 31 are shorter than the length of the case and are adapted to be folded into substantially parallel and horizontal positions alongside each other as illustrated in Fig. 1.

The pivotal arms are adapted to be extended upward in vertical direction and said arms have their free ends recessed or bifurcated (as shown) to receive and hold the opposite ends respectively of a bar or rod 29—b in hemmed edge 29—a so that the screen will be held in withdrawn position in a substantially flat plane between arms 31 and 32 as illustrated in Fig. 1.

When it is desired to fold away the screen, the user disengages the bar 29—b from the recessed ends of arms 30 and 31 and allows the spring (not shown) of the roller to roll up the screen in a manner similar to a window shade.

The case may be easily mounted upon a table or other available support at the location of desired projection so that the screen, when extended, will be at desired height. However, as supports are not convenient in many locations, I provide an efficient normally concealed supporting means. This comprises four metal legs 33, each of which are preferably formed of two pivoted together sections, the short sections being externally threaded and designated as 33—a, as shown in Fig. 1.

As shown in Fig. 2, the bottom 19 has suitably mounted therein near the four corners thereof four internally threaded bushings or fittings 34 into which the threaded studs 33—a are adapted to be threaded. After such threading the pivoted legs may be extended in any one of many positions and angles to thereby selectively adjust the height of the case and contained screen to the most desirable position according to the particular case. The free ends of legs 33 are preferably provided with rubber grips or members 35 so that when the legs are pivoted in inclined positions, (as in Fig. 3) the legs will not slip along the floor or other supporting surface.

The inside face of the panel 19 of the cover is preferably provided with four pairs of spaced apart metal yieldable retaining clips 36 into which the legs 33 may be releasably mounted respectively, as shown in Fig. 1, when the device is to be carried from place to place. The pivotal connection between threaded studs 33—a and legs 33 provides for allowing the legs to remain in mounted position in the bottom 11 and the respective legs 33 folded alongside the bottom so that convenient portage of the device may be had without removal of said legs.

The carrying case provides ample room for removably mounting a projector 37 and containers for film and other paraphernalia which are illustrated by numerals 38 and 39 in Fig. 1. A flat shelf or panel 40 secured a short distance above the bottom 10 is preferably provided and upon which a projection and containers preferably are supported during portage.

I am aware that various changes may be made in the embodiment of the invention herein specifically described without departing from or sacrificing any of the advantages of the invention or any features thereof, and nothing herein shall be construed as limitations upon the invention, its concept or structural embodiment as to the whole or any part thereof.

I claim:

1. In a combination carrying device and sup-

port for a rollable screen; a case of substantially rectangular form having opposite end walls whose upper corner sections are cut away at one side and said case having one relatively shallow side wall, the edges of said shallow side wall and said cut away portions of said end wall defining an opening; a closure pivotally connected to the upper portion of said case adapted, when closed, to close said opening; a pair of mounting brackets at the opposite ends of the lower part of said case; a roller rotatably mounted in said brackets; a flexible screen mounted on said roller; a pair of arms pivoted at the opposite ends of said case respectively and adapted to be swung to vertically extending position; said screen being attachable, when withdrawn, to the upper end portions of said arms to thereby hold said screen in substantially vertical plane; and legs removably mounted in the bottom portion of said case, said legs being adapted to be carried in said case during portage of said device.

2. In a combination carrying device and support for a rollable screen; a case of substantially rectangular form having opposite end walls whose upper corner sections are cut away at one side and said case having one relatively shallow side wall, the edges of said shallow side wall and said cut away portions of said end wall defining an opening; a closure pivotally connected to the upper portion of said case adapted, when closed, to close said opening; a pair of mounting brackets at the opposite ends of the lower part of said case; a roller rotatably mounted in said brackets; a flexible screen mounted on said roller; a pair of arms pivoted at the opposite ends of said case respectively and adapted to be swung to vertically extending position; said screen being attachable, when withdrawn, to the upper end portions of said arms to thereby hold said screen in a substantially vertical plane; a plurality of threaded fastening elements in the bottom portion of said case; and legs, each comprising an elongated rigid section and a shorter threaded pivotally connected section adapted to be removably threaded in said fastening elements and extended outwardly to support said device above a supporting device.

3. In a portable device of the described class, an elongated carrying case having an opening; a cover pivotally connected to said case adapted to close said opening; a pair of arms pivoted at one end of each thereof to opposite end portions of said case and adapted to be extended upwardly; a roll screen rotatably mounted in the lower part of said case, the edge portion of said screen being attachable to the upper ends of said arms when said arms are extended to thereby hold said screen in substantially vertical plane, and a plurality of legs detachably connected to the bottom portion of said case and adapted to support said device above a supporting surface.

ALDEN R. HERLACHE.

REFERENCES CITED

The following references are of record in the file of this patent:

UNITED STATES PATENTS

Number	Name	Date
1,820,739	Heck	Aug. 25, 1931
1,902,373	Pineo	Mar. 21, 1933
2,364,695	Coleman	Dec. 12, 1944
2,382,025	Raven	Aug. 14, 1945