



- (51) International Patent Classification: Not classified
- (21) International Application Number: PCT/GB2013/051799
- (22) International Filing Date: 8 July 2013 (08.07.2013)
- (25) Filing Language: English
- (26) Publication Language: English
- (30) Priority Data: 1212240.4 10 July 2012 (10.07.2012) GB
- (71) Applicant: ENOVATE SYSTEMS LIMITED [GB/GB]; Unit A, Howemoss Drive, Kirkhill Industrial Estate, Dyce, Aberdeen, Aberdeenshire AB21 0GL (GB).
- (72) Inventor: EDWARDS, Jeffrey; Enovate Systems Limited, Unit A Howemoss Drive, Kirkhill Industrial Estate, Dyce, Aberdeen Aberdeenshire AB21 0GL (GB).
- (74) Agent: NAISMITH, Robert; Marks & Clerk LLP, Aurora, 120 Bothwell Street, Glasgow G2 7JS (GB).
- (81) Designated States (unless otherwise indicated, for every kind of national protection available): AE, AG, AL, AM,

AO, AT, AU, AZ, BA, BB, BG, BH, BN, BR, BW, BY, BZ, CA, CH, CL, CN, CO, CR, CU, CZ, DE, DK, DM, DO, DZ, EC, EE, EG, ES, FI, GB, GD, GE, GH, GM, GT, HN, HR, HU, ID, IL, IN, IS, JP, KE, KG, KN, KP, KR, KZ, LA, LC, LK, LR, LS, LT, LU, LY, MA, MD, ME, MG, MK, MN, MW, MX, MY, MZ, NA, NG, NI, NO, NZ, OM, PA, PE, PG, PH, PL, PT, QA, RO, RS, RU, RW, SC, SD, SE, SG, SK, SL, SM, ST, SV, SY, TH, TJ, TM, TN, TR, TT, TZ, UA, UG, US, UZ, VC, VN, ZA, ZM, ZW.

- (84) Designated States (unless otherwise indicated, for every kind of regional protection available): ARIPO (BW, GH, GM, KE, LR, LS, MW, MZ, NA, RW, SD, SL, SZ, TZ, UG, ZM, ZW), Eurasian (AM, AZ, BY, KG, KZ, RU, TJ, TM), European (AL, AT, BE, BG, CH, CY, CZ, DE, DK, EE, ES, FI, FR, GB, GR, HR, HU, IE, IS, IT, LT, LU, LV, MC, MK, MT, NL, NO, PL, PT, RO, RS, SE, SI, SK, SM, TR), OAPI (BF, BJ, CF, CG, CI, CM, GA, GN, GQ, GW, KM, ML, MR, NE, SN, TD, TG).

Published:

- without international search report and to be republished upon receipt of that report (Rule 48.2(g))

(54) Title: IMPROVED BLOW OUT PREVENTER

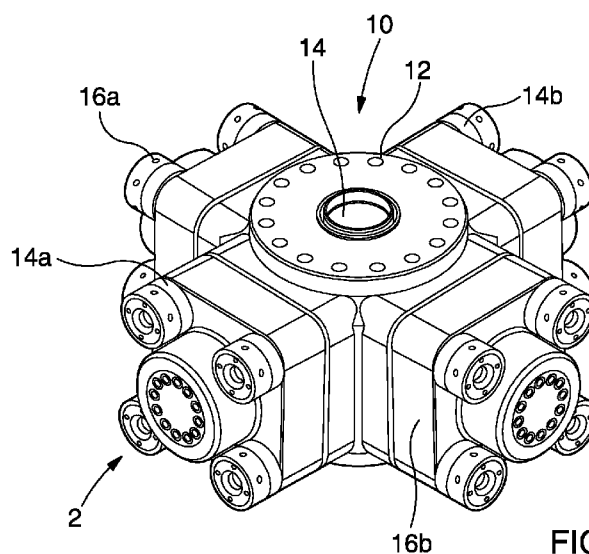

FIG. 1

(57) Abstract: A BOP device is disclosed which has two pairs of opposed rams located in a single plane with the pairs of rams being disposed in the plane so that the pairs of rams move in directions orthogonal to each other. This means that the same number of rams can be deployed in a BOP device half the height. One BOP unit can have two sets of pipe rams, with the pipe rams being by having pipe ram heads sized to accommodate different diameters and a second BOP unit can have a set of pipe rams and a set of shear or blade rams for being actuated to seal off the BOP. Thus, four sets of rams can be disposed in a height approximately 50% of that formerly accommodated by four sets of rams thus minimising the weight of the BOP structure and significantly reducing the bending moment by around 50% on the wellhead. Embodiments of the invention are described.



Improved Blow Out Preventer

The present invention relates to Blow Out Preventers (BOP's), particularly but not exclusively to ram-type BOP's

5

A Blow Out Preventer, commonly known by the abbreviation BOP, is a well known safety devices for sealing off oil or gas wells during emergency situations so as to contain potentially dangerous blow outs. When a BOP fails to operate, the consequences can be catastrophic and environmentally damaging such as occurred in the failure of the BOP's in the Deepwater Horizon rig. The two most prevalent types of Blow Out Preventers may be categorised as a ram-type and an annular-type. BOP stacks frequently use both types with at least one annular Blow Out Preventer (BOP) stacked above several ram BOP's. The ram-type BOP includes a housing which defines a through bore for providing access to the well and at least one pair of rams mounted in the housing; the rams of each pair being opposed and being located on opposite sides of the through bore. The rams carry ram heads, which when actuated such as in the event of an emergency, move toward each other and the ram heads close or seal off the through bore thereby sealing off the well.

10

15

20

Sealing the throughbore is assisted by the provision of elastomer seal elements incorporated in the ram body. The first of these seal elements is disposed on the upward facing surface of the rams, for engaging with a seal surface machined into the ram cavity, and the second element is disposed on the inward facing vertical surface of the ram. These seal elements are positioned such that when the rams are moved to the closed condition, and the inward facing vertical surfaces are in contact, a continuous elastomer seal is formed between the ram bodies and their cavities and also between the contacting faces of the rams.

25

When the rams are in the closed condition and the pressure below the rams is higher than the pressure above, the rams are forced to move upwards towards the upper surface of the ram cavity. This improves sealing benefits as the seals are pressed progressively harder against the cavity, and the extrusion gap is reduced.

30

However, conventional BOP's have a disadvantage in that if the pressure above the rams is greater than the pressure below, these two benefits do not occur. In such a

35

case, the rams float downwards, away from the cavity sealing surface, simultaneously unloading the seal and increasing the extrusion gap. This behaviour is one reason which explains why ram-type BOP's are not reliable for containing pressures from above.

5

Applicant's granted European patent EP179957B discloses a seal seat arrangement for engaging with rams seals in which a seal seat associated with each pair of rams can be movably mounted within a ram cavity such that the seal seat continuously engages the rams as the rams move from a cavity open to a cavity closed position.

10

Existing BOP's are generally very large because they have several ram BOP's stacked in series with the result that the BOP structure necessary for use in offshore oil and gas rigs can be up to 60 feet high and can weigh at least 60 tonnes. This provides a significant deployment problem because of the weight of the structure. In addition, because of the vertical orientation and weight of the structure, pressure on the structure by virtue of sea movement of currents can provide a significant bending moment on the structure, particularly at the lower wellhead end which increases the risk of failure. The tendency following well-publicised failures has to be to increase size and weight of such structures in making the pipe and rams ever bigger and heavier, but this type of solution gives rise to the aforementioned increased weight and bending moment problems. In addition to providing deployment problems these overall structures are exceptionally expensive to produce and this can have a deterrent effect on drilling and deploying oil structures.

15

20

25

The object of the present invention is to provide an improved BOP structure which obviates or mitigates at least one of the above-mentioned problems.

30

This is achieved, in its broadest aspect, by disposing two pairs of opposed rams in a single plane with the pairs of rams being disposed in the plane so that the pairs of rams move in directions orthogonal to each other. This means that the same number of rams can be deployed in a BOP device half the height. One BOP unit can have two sets of pipe rams, with the pipe rams being by having pipe ram heads sized to accommodate different diameters and a second BOP unit can have a set of pipe rams and a set of shear or blade rams for being actuated to seal off the BOP. Thus, four sets of rams can be disposed in a height 50% of that formerly accommodated by four sets of rams thus

35

minimising the weight of the BOP structure and significantly reducing the bending moment by around 50% on the wellhead. In addition, it will be understood that the sealing arrangement of the rams is such that the physical length of the rams are considerably less than with standard rams, again reducing the weight.

5

According to a first aspect of the present invention, there is provided a BOP device having a throughbore and:

a first pair of rams disposed in a first plane;

a second pair of rams disposed in said first plane;

10

said first pair of rams being orientated to moving in said first plane in a direction substantially orthogonal to said second pair of rams.

15

Preferably one pair of rams of said first and second pair of rams are pipe rams for sealing around a cylindrical pipe. Preferably also the other pair of said first and second pair of rams are shear rams for cutting through a pipe disposed in said BOP throughbore.

20

Preferably at least two BOP devices are coupled in series to provide a continuous throughbore, one of said BOP devices having two pairs of pipe rams and the other device having one pair of shear rams. Advantageously one of the two pairs of pipe rams carry pipe ram blocks of a first size and the other pipe ram having pipe ram blocks of a second size, said first and second pipe ram sizes adapted to engage cylindrical pipe or objects of different sizes in said continuous throughbore.

25

Preferably also said ram housing contains at least one seal seat arranged in the ram cavity, said seal seat associated with each pair of rams, the at least one seal seat having a seal surface for continuously engaging with the ram seals as the at least one pair of rams move from the first position to a second position.

30

Conveniently the seal seat is movably mounted in the ram cavity. Preferably also the seal seat is hard faced by adding a coating of metal or alloy to a component to produce a polished surface of exceptional resistance to scratching and degradation.

35

Conveniently also the elongate seal seat has been ground.

According to a further aspect of the present invention there is provided a method of reducing BOP height and weight whilst retaining BOP capability by disposing in a first BOP a first set of BOP rams in a first plane for moving in said first plane in a first direction;

- 5 disposing a second set of BOP rams in said first plane for moving in a second direction;
- arranging said first and second directions to be substantially orthogonal.

10 Preferably also said method includes the steps of coupling a second BOP device to said first device and disposing a third and a fourth set of BOP rams in a second plane, substantially parallel to said first plane, and arranging said third and fourth sets to move in orthogonal directions in said second plane.

15 Preferably said method includes providing said first and said second rams with pipe ram heads and providing said third and fourth rams with shear ram heads. These and other aspects of the invention will become apparent from the following description when taken in combination with the accompanying drawings in which:

20 Fig. 1 is a perspective view of a Blow Out Preventer in accordance with an embodiment of the present invention;

 Fig. 2 is a side view of the Blow Out Preventer of Fig. 1;

 Fig. 3 is a sectional view taken on the line A-A of Fig. 2;

25 Fig. 4 is a sectional view taken on the line B-B of Fig.3 and drawn to a larger scale with a set of pipe rams and a set of blind rams in the open position;

 Fig. 5 is a view similar to Fig. 4 but with the pipe rams shown in the closed position;

30 Fig. 6 is a view similar to Fig. 4 but with the blind rams shown in the closed position;

 Fig. 7 is an enlarged and perspective view of a pipe ram head showing the ram head seal in detail;

Fig. 8a depicts a Blow Out Preventer in accordance with an embodiment of the present invention in which two of the devices shown in Fig. 1 are stacked (with Fig. 8b showing a prior art structure for comparison);

5 Fig. 9 is a side view of the stacked structure shown in Fig. 8a; and

Fig. 10 is a sectional view of the stacked structure of Fig. 9 taken in the direction of arrows 10-10.

10 Reference is now made to Fig. 1 of the drawings which depicts a Blow Out Preventer device generally indicated by reference numeral 10 in accordance with an embodiment of the present invention. The device has a housing 12 which defines a throughbore 14 which is adapted to receive a cylindrical downhole object such as a drill pipe (not shown in the interests of clarity) and which can be sealed by a set of rams or sheared
15 by a set of rams which are located in ram housings 14a, 14b and 16a, 16b respectively. The ram housings 14a, 14b and 16a, 16b are located so that the rams which they contain, as will be later described in detail, are disposed in orthogonal axis and move in the same plane in orthogonal directions to each other.

20 Reference is now made to Fig. 2 of the drawings in which it will be seen that ram housings 16a, 14a and 16b are located in the same plane 19.

Reference is now made to Fig. 3 of the drawings which is a section through Fig. 2 taken on the lines A-A. In Fig. 3 it will be seen that the throughbore 14 passes through
25 the housing 12 between a top aperture 14a and a bottom aperture 14b. Disposed in the ram housing 16a and 16b are disposed opposed blind ram pistons 18a and 18b which carry blind ram blocks 20a and 20b respectively. These ram blocks 20a, 20b are shown in the open position and it will be understood that when the rams are actuated to the closed position, as best seen in Fig. 6, the wellbore 14 is sealed by the blind rams. It
30 will be understood that all of the blind rams 18a, 19b are pistons which are hydraulically actuated in accordance with well known hydraulic actuation technology.

Each blind ram block 20a, 20b carries an elastomeric ram seal 22a, 22b. The ram seal is disposed on the abutting face 24a, 24b of each ram and continues from the ram face
35 to the top surface where the seal forms a generally semicircular seal 26a, 26b such

that when the rams 18a, 18b are closed as shown in Fig. 6 the top seal forms a substantially circular seal. This circular seal abuts the bottom of a sealing seat 28a, 28b as shown in Fig. 3. This arrangement is disclosed in applicant's European patent number EP179957B and has the advantage that the seal elements 26a, 26b are in constant contact with the seal seats 28a, 28b when in the closed and when in the open position, thus providing all the sealing advantages disclosed in the above mentioned patent.

Reference is now made to Fig. 4 of the drawings which depicts the pipe ram pistons 23a, 23b and blind rams 18a, 18b in the open position so that the bore 14 is clear. It will be seen that the pipe rams 23a, 23b have ram blocks 30a, 30b which also contain pipe facing seal portions 32a, 32b for engaging with a pipe when the pipe passes through the bore 14. In Fig. 4 it will be seen that the blind rams 18a, 18b are opposed and move towards and away from each other along a first direction X and the pipe rams are also opposed and move towards and away from each other along a second direction Y. X and Y are on the same plane 19 and the directions X and Y are orthogonal to each other.

Reference is now made to Fig. 5 of the drawings which depicts the pipe rams in a closed position with the seals 32a, 32b abutting so as to seal around a pipe 34. In Fig. 5 it will be seen that the blind rams 18a, 18b remain retracted.

Referring again to Fig. 6 it will be seen that the pipe rams 23a, 23b are retracted and in this case the blind rams 18a, 18b are actuated so the ram blocks 20a, 20b abut and seal the bore 14 as shown. The blind rams may be shear rams with cutting heads to sever the pipe at any other longitudinal element disposed in the bore 14.

Reference is now made to Fig. 7 which depicts an enlarged view of the pipe ram block 30a shown in Figs. 4, 5 and 6. In this case it will be seen that the pipe ram block 30a defines a semicircular opening 36 in which is located a semicircular portion 38a of the ram seal for sealing around a pipe or longitudinal element 34. The ram seal has an upper portion 40a for abutting the underside of the polished surface seal seat 28 as shown in Fig. 3, thus providing the advantageous sealing effect from pressure above and below the BOP as disclosed above. The elastomeric seal provides a close fit

around pipe arrangements and to accommodate any slight variations in size tolerances which providing and maintaining a sealing relationship of the required performance.

Reference is now made to Fig. 8 of the drawings which depicts two stacked or doubled-up BOP devices 10 to form a composite BOP unit 50 in which the throughbore 14 extends through both the coupled units as best seen in Fig. 10. For comparison, Fig. 8b shows a prior art arrangement where the prior art devices are stacked together but because pairs of rams are not in the same plane, the structure is approximately 50% higher and because of this arrangement the device is both heavier because of the extra longitudinal housing and the additional height causes a larger bending moment particularly at the base of the combined series unit which is undesirable from a safety point of view. Fig. 9 depicts an end view in the direction of arrow 9 in Fig. 8a and it will be seen that the pairs of rams in units 10 and 11 lie in respect of parallel planes 52, 54 such that the pairs of rams best seen in Fig. 10 move in these planes 52, 54 but with each pair of rams in the respective BOP 10, 11 moving in an orthogonal direction to the other pair of rams in that unit.

It will be understood that the Blow Out Preventer device in accordance with the present invention provides significant advantages over existing BOP devices in that it is a more compact structure, it is lighter and can be combined to form a compact BOP series device that is about 50% less weight than existing devices and is only about half as tall, thus reducing the bending moment by about 50%.

Various modifications may be made to the embodiment hereinbefore described without departing from the scope of the invention. For example, each device may include two sets of pipe rams or one set of pipe rams and one set of shear rams or indeed two sets of shear rams, depending on the specific requirements of the well, thus providing the BOP designer with a flexible system to accommodate the specific operator requirements. The rams are hydraulically powered, although manual overrides can also be provided such that the rams can be actuated using an ROV in accordance with local operational requirements. The BOP structure in accordance with the present invention, being much lighter, is more easily deployed and stackable compared to conventional units. In addition, varying the pipe rams within one device provides the flexibility in a single unit of minimal height to accommodate and seal pipes of different diameters.

The use of the floating seals provides the advantage that both rams in the single plane have the same advantageous sealing arrangement over the prior art structures.

5

10

15

20

25

30

CLAIMS:

1. A BOP device having a throughbore and:
a first pair of rams disposed in a first plane;
5 a second pair of rams disposed in said first plane;
said first pair of rams being orientated to moving in said first plane in a direction substantially orthogonal to said second pair of rams.
2. A device as claimed in claim 1 wherein said one pair of rams of said first and
10 said second pair of rams are pipe rams for sealing around a pipe.
3. A device as claimed in claim 2 wherein the other pair of said first and said
second pair of rams are shear rams for cutting through a pipe disposed in said BOP
throughbore.
15
4. A BOP as claimed in any one of claims 1 to 3 wherein at least two BOP devices
are coupled in series to provide a continuous throughbore, one of said BOP devices
having two pairs of pipe rams and the other device having one pair of shear rams.
- 20 5. A BOP as claimed in claim 4 wherein one of two pairs of pipe rams carry pipe
ram heads of a first size, and the other pipe ram having pipe ram heads of a second
size, said first and said second sizes adapt to engage cylindrical pipes or objects of
different sizes when in said continuous throughbore.
- 25 6. A method of reducing BOP height and weight whilst retaining full BOP capability
by disposing in a first BOP a first set of BOP rams in a first plane for moving in said
plane in a first direction;
disposing a second set of BOP rams in said first plane for moving in a second
direction;
30 arranging said first and second directions to be substantially orthogonal.
7. A method as claimed in claim 6 wherein said method includes the steps of
coupling a second BOP device to said first device and disposing a third and a fourth set
of BOP rams in a second plane, substantially parallel to said first plane, and arranging
35 said third and fourth sets to move in orthogonal directions in said second plane.

8. A method as claimed in claim 7 including providing said first and said second rams with pipe ram heads and providing said third and fourth rams with shear ram heads.

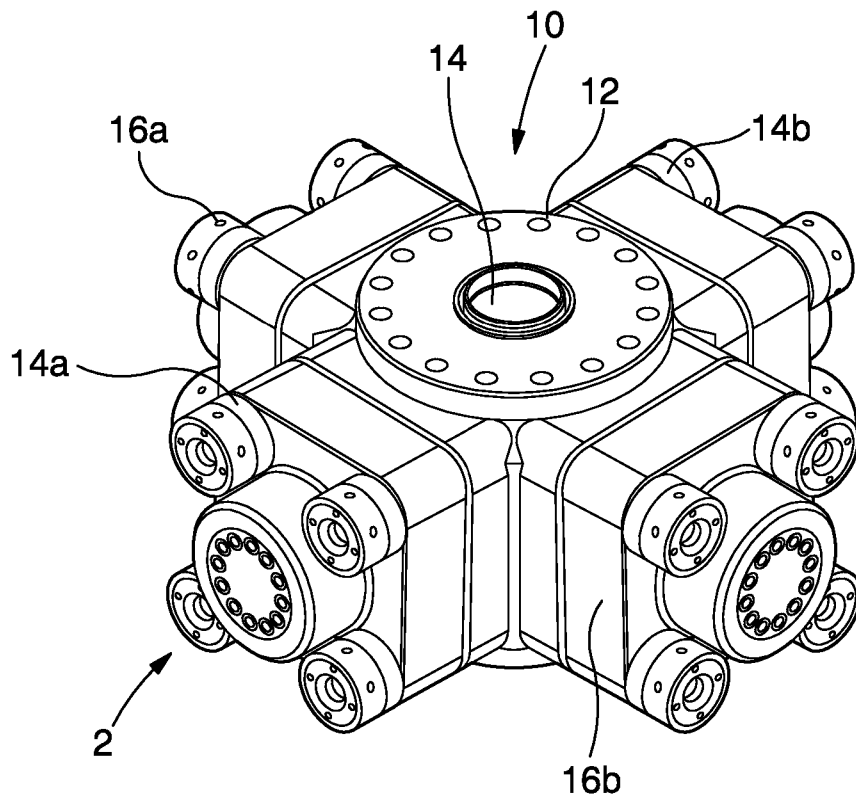

FIG. 1

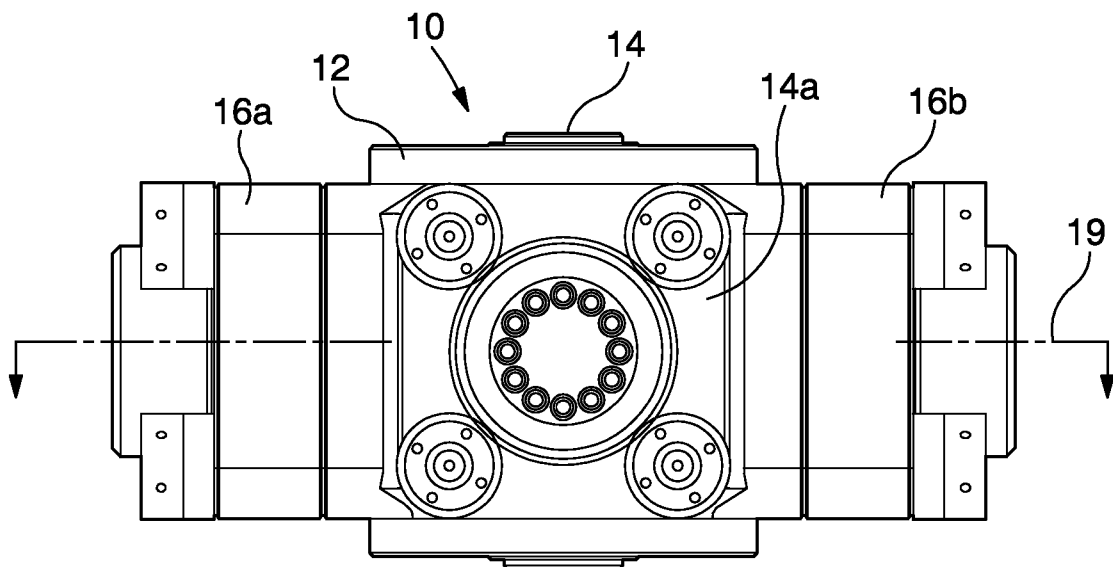
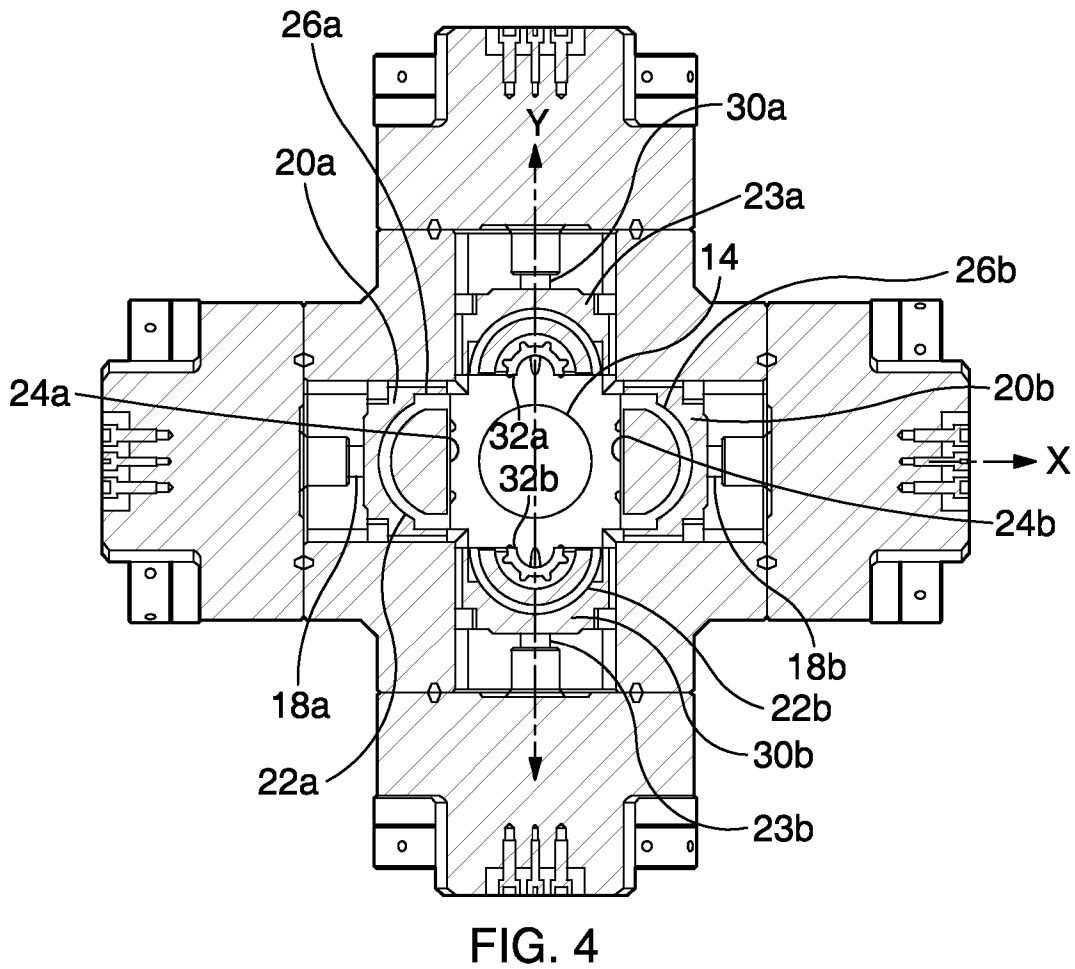
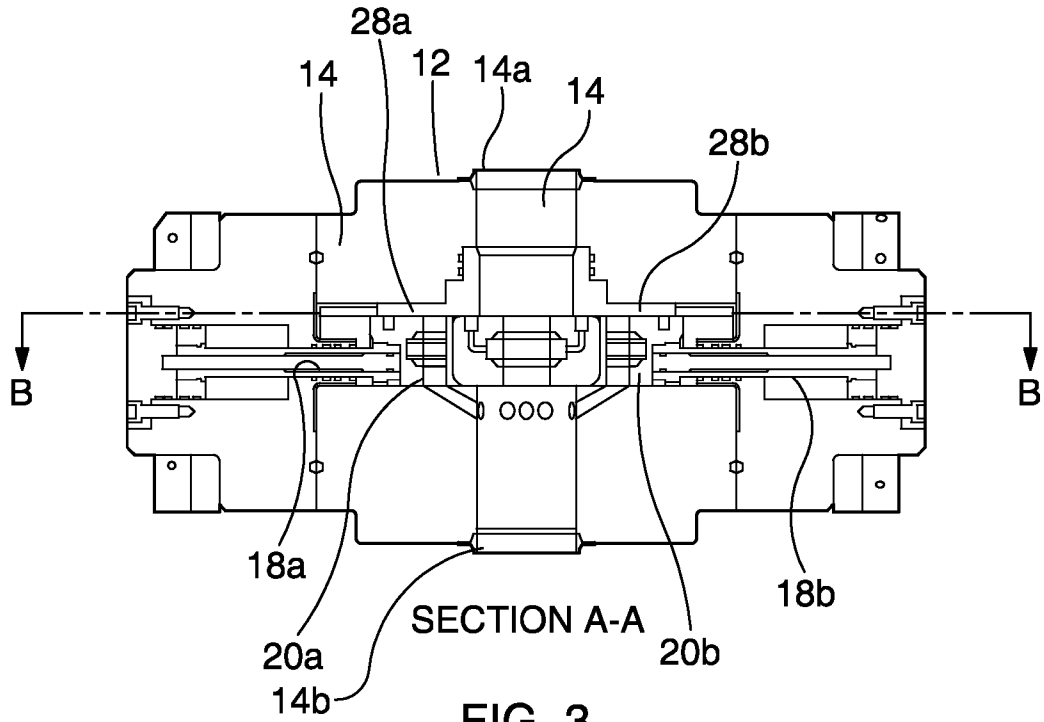

FIG. 2



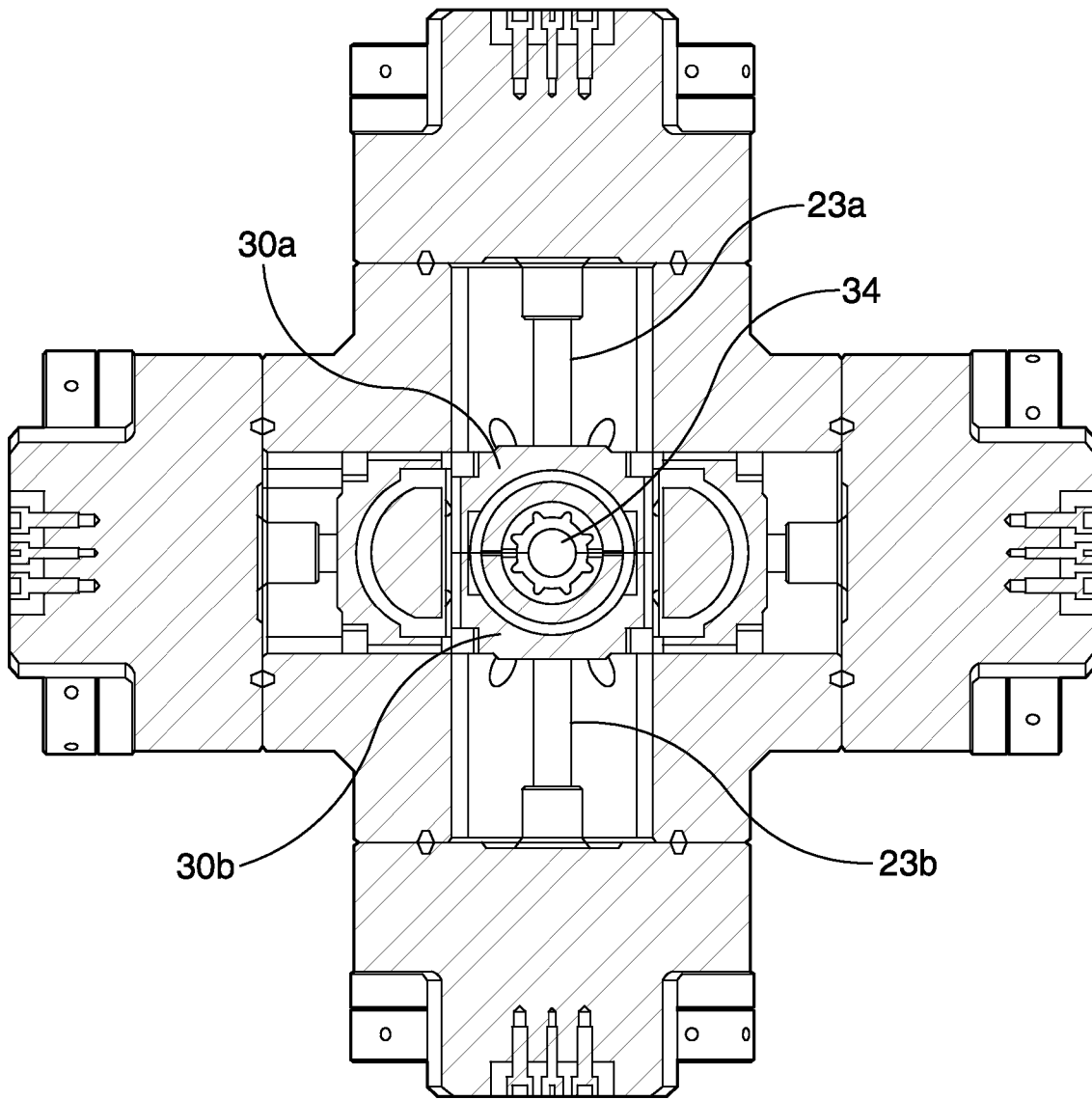

FIG. 5

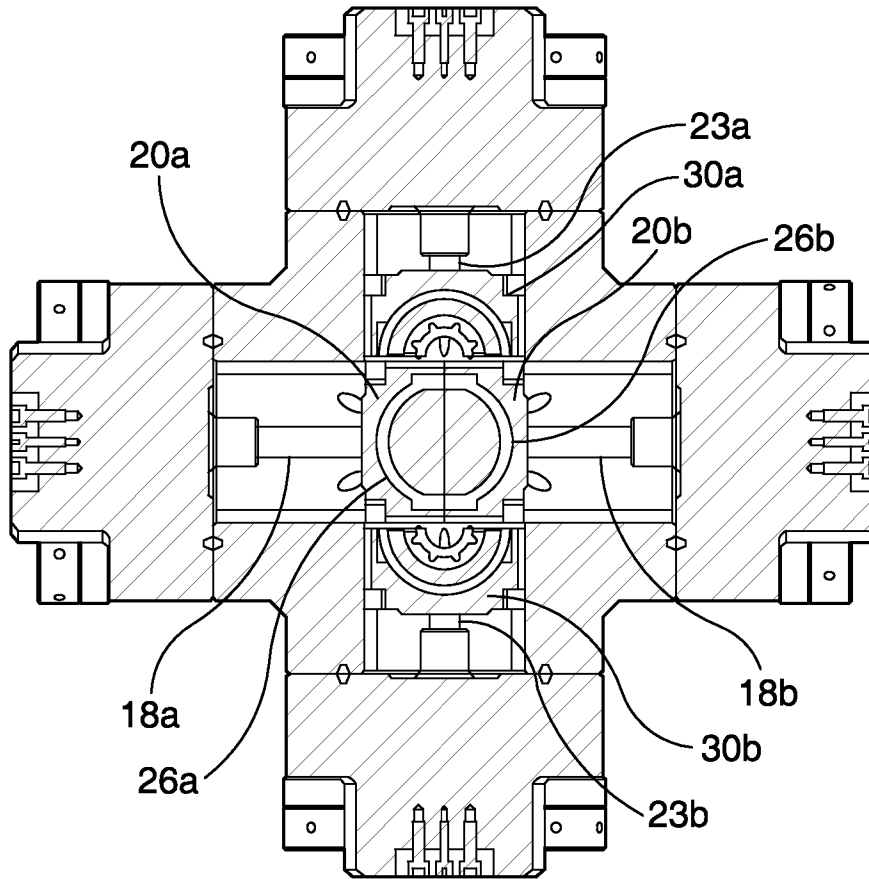

FIG. 6

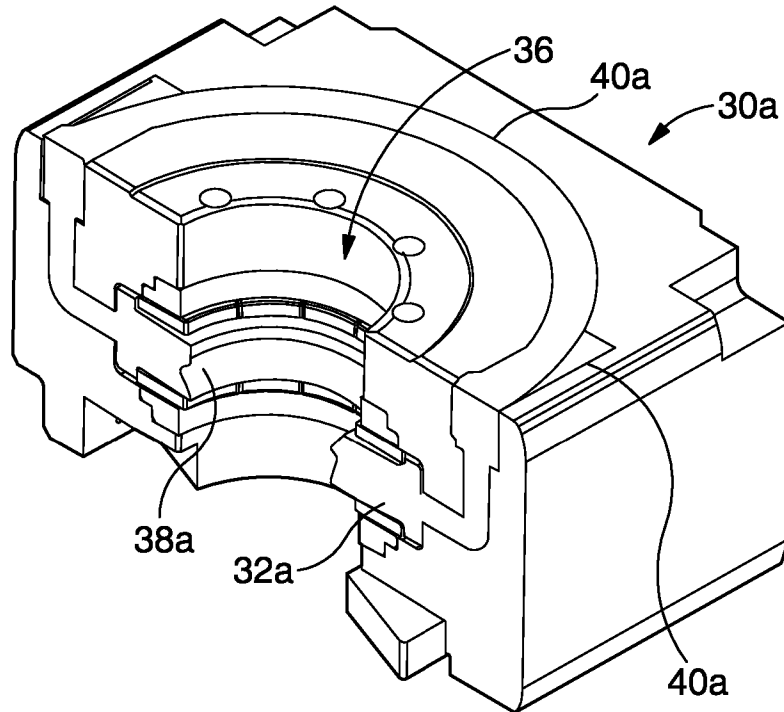

FIG. 7

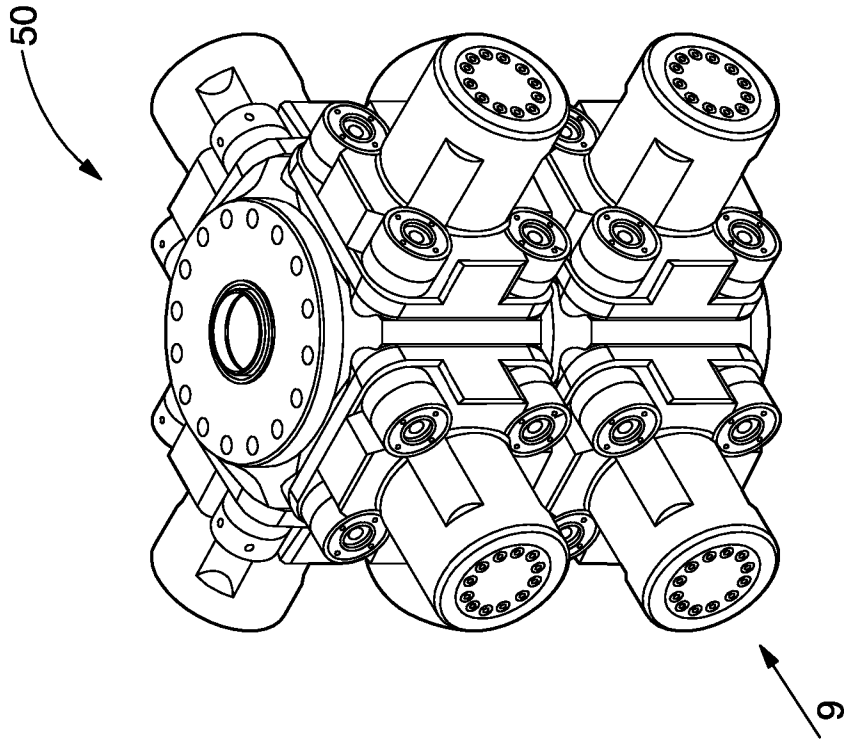

FIG. 8a

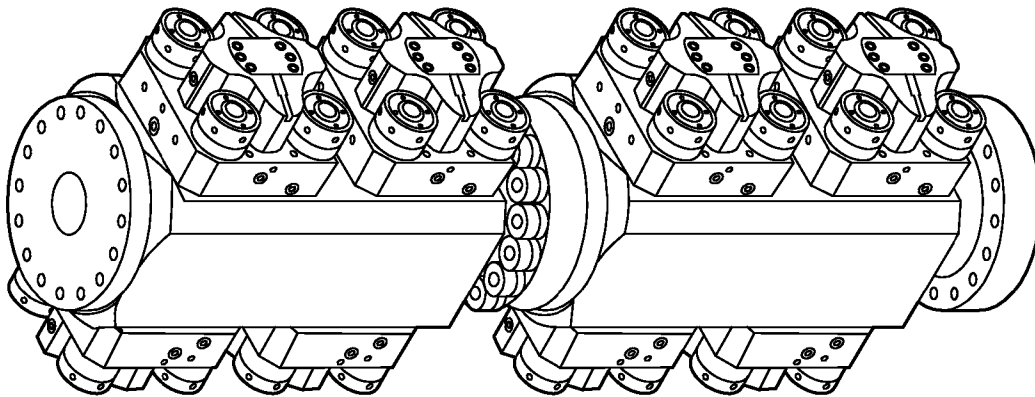

FIG. 8b (PRIOR ART)

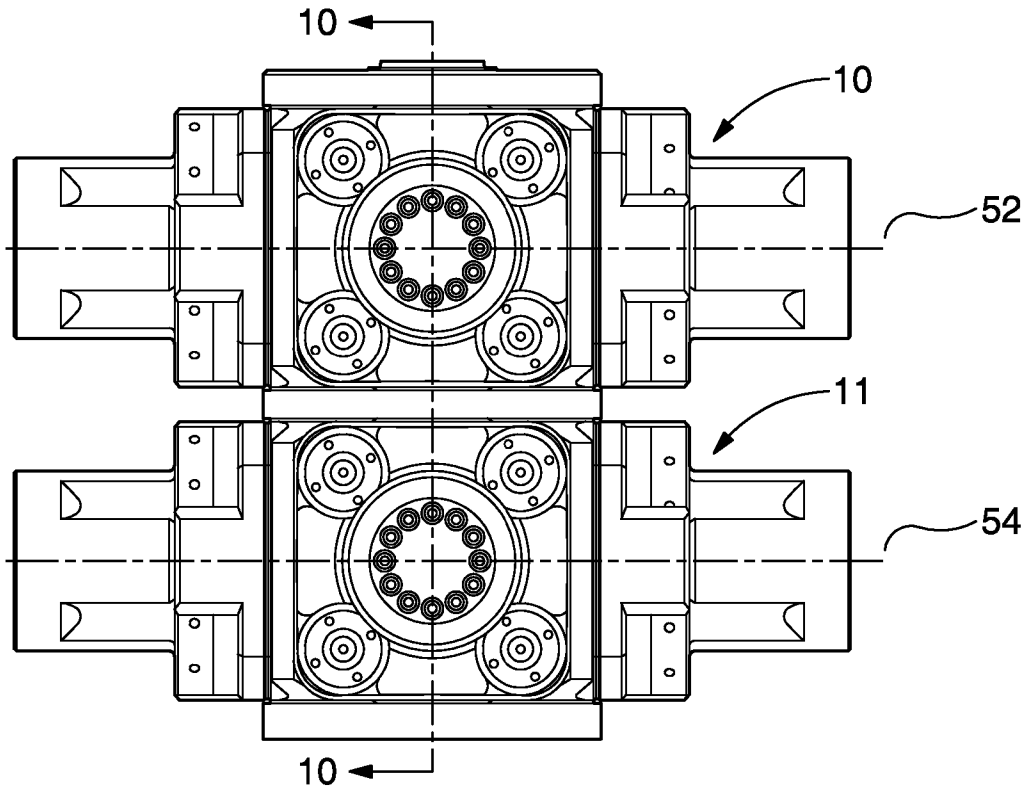

FIG. 9

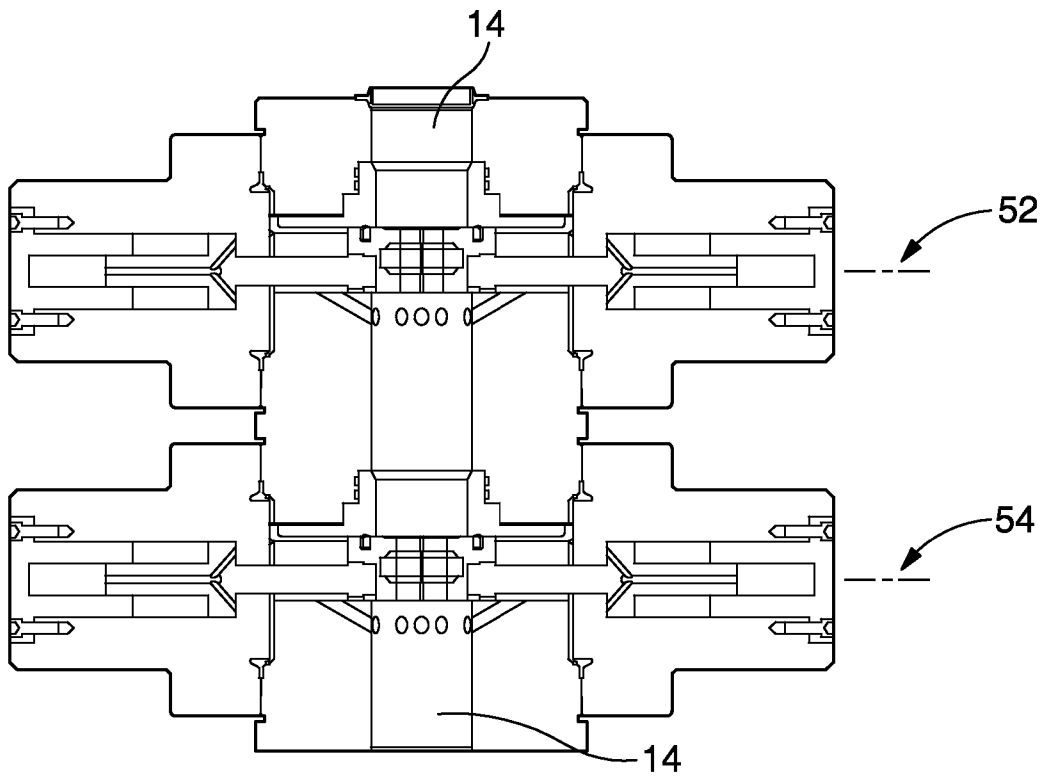

FIG. 10